



King's Research Portal

DOI:

[10.1016/j.visres.2008.03.009](https://doi.org/10.1016/j.visres.2008.03.009)

Document Version

Peer reviewed version

[Link to publication record in King's Research Portal](#)

Citation for published version (APA):

Spratling, M. W. (2008). Predictive coding as a model of biased competition in visual attention. *Vision Research*, 48(12), 1391 - 1408. <https://doi.org/10.1016/j.visres.2008.03.009>

Citing this paper

Please note that where the full-text provided on King's Research Portal is the Author Accepted Manuscript or Post-Print version this may differ from the final Published version. If citing, it is advised that you check and use the publisher's definitive version for pagination, volume/issue, and date of publication details. And where the final published version is provided on the Research Portal, if citing you are again advised to check the publisher's website for any subsequent corrections.

General rights

Copyright and moral rights for the publications made accessible in the Research Portal are retained by the authors and/or other copyright owners and it is a condition of accessing publications that users recognize and abide by the legal requirements associated with these rights.

- Users may download and print one copy of any publication from the Research Portal for the purpose of private study or research.
- You may not further distribute the material or use it for any profit-making activity or commercial gain
- You may freely distribute the URL identifying the publication in the Research Portal

Take down policy

If you believe that this document breaches copyright please contact librarypure@kcl.ac.uk providing details, and we will remove access to the work immediately and investigate your claim.

Predictive Coding as a Model of Biased Competition in Visual Attention

M. W. Spratling

Division of Engineering, King's College London, UK.

and

Centre for Brain and Cognitive Development, Birkbeck, University of London, UK.

Abstract

Attention acts, through cortical feedback pathways, to enhance the response of cells encoding expected or predicted information. Such observations are inconsistent with the predictive coding theory of cortical function which proposes that feedback acts to suppress information predicted by higher-level cortical regions. Despite this discrepancy, this article demonstrates that the predictive coding model can be used to simulate a number of the effects of attention. This is achieved via a simple mathematical rearrangement of the predictive coding model, which allows it to be interpreted as a form of biased competition model. Nonlinear extensions to the model are proposed that enable it to explain a wider range of data.

Keywords: neural networks; cortical circuits; cortical feedback; attention; binding problem

1 Introduction

The predictive coding (PC) model of cortical visual information processing (Rao and Ballard, 1999) proposes a hierarchical neural network architecture in which perception is accomplished via the interaction of top-down expectation and sensory-driven analysis. Rather than passively responding to the output activity generated by preceding stages of cortical processing, PC proposes that higher levels of cortex actively predict the input they expect to receive. Furthermore, it is proposed that cortical feedback connections convey predictions while cortical feedforward connections convey residual errors between these top-down predictions and the bottom-up input. Hence, PC, in common with several previous theories (e.g., Barlow, 1994; Mumford, 1992), hypothesises that cortical feedback connections act to suppress information which is predicted by higher-level cortical regions. It has previously been noted (Hamker, 2006; Koch and Poggio, 1999) that this role for cortical feedback appears to be inconsistent with physiological data showing that the effects of cortical feedback are predominately excitatory (Johnson and Burkhalter, 1997; Shao and Burkhalter, 1996). In particular, the inhibitory cortical feedback proposed in the predictive coding model seems inconsistent with single-cell electrophysiological experiments exploring the effects of attention. In such experiments, attention is manipulated by inducing an expectation about the location or features of a subsequently presented stimulus. This has been shown to produce an increase in the amplitude of the neural activity generated in response to an attended (*i.e.*, predicted) stimulus (Hupé et al., 1998; Kastner and Ungerleider, 2000; Luck et al., 1997a; Olson, 2001; Schroeder et al., 2001). Given the apparent inconsistency between the predictions of PC and the empirical data it would be unexpected that PC could be used to simulate single-cell electrophysiological data associated with attention. However, this article demonstrates that attention experiments can be simulated, very easily, using the PC model.

A neural network implementation of PC requires two populations of neurons to model each cortical region (see Figure 1a). Firstly, a population of prediction nodes is required to provide top-down predictions to earlier processing stages. Secondly, a population of error-detecting nodes is required to calculate the residual error between the top-down predictions and the bottom-up input. Descriptions of PC tend to emphasise the importance of the error-detecting nodes, and hence stress the suppression of activity caused in these nodes by top-down predictions. However, this emphasis is misleading as the prediction nodes, which are required to maintain an active representation of the (predicted) input, are equally important to the functioning of the model. These prediction nodes are equivalent to the representational nodes employed in many biased competition (BC) models. Indeed, it is shown in Section 2 (and Spratling, 2008) that PC is mathematically equivalent to a particular form of BC model in which nodes compete via negative feedback (Harpur and Prager, 1996, 1994; Spratling and Johnson, 2004). It is for this reason that the responses generated by the prediction nodes in the PC model can be used to simulate attention data.

One limitation of the PC model is that it is purely linear. A more computationally powerful model might include nonlinearities. Hence, this article also proposes a nonlinear version of PC and demonstrates that this can more accurately simulate the effects of attention. It is also shown to provide a theoretical explanation, consistent with previous theories (Roelfsema, 2006; Roelfsema et al., 2000), for the role of attention in solving the binding problem.

2 Methods

2.1 Predictive Coding

Rao and Ballard (1999) implemented PC using a model in which the responses (\mathbf{y}) of the prediction nodes (at a particular stage of the hierarchy, *i.e.*, S_i) were calculated using the following equation:

$$\mathbf{y}^{S_i} \leftarrow \mathbf{y}^{S_i} + \zeta \mathbf{W}^{S_i} \left[\mathbf{x} - (\mathbf{W}^{S_i})^T \mathbf{y}^{S_i} \right] + \eta (\mathbf{y}^{td} - \mathbf{y}^{S_i}) - \vartheta \mathbf{y}^{S_i} \quad (1)$$

Where superscripts of the form S_i indicate processing stage i of the hierarchical neural network, $\mathbf{y}^{S_i} = [y_1^{S_i}, \dots, y_n^{S_i}]^T$ is a vector of prediction node activations, $\mathbf{x} = [x_1, \dots, x_m]^T = \mathbf{y}^{S_0}$ is a vector of inputs to the hierarchy (coming from a more peripheral cortical or thalamic region that is not explicitly modelled), $\mathbf{y}^{td} = (\mathbf{W}^{S_{i+1}})^T \mathbf{y}^{S_{i+1}}$ is the top-down prediction from the next highest stage, $\mathbf{W}^{S_i} = [\mathbf{w}_1^{S_i}, \dots, \mathbf{w}_n^{S_i}]^T$ is an n by m matrix of synaptic weight values, each row of which contains the feedforward weights received by a single node, and ζ , η , and ϑ are constant scale factors. Note that in certain simulations presented by Rao and Ballard (1999) a variation on the above algorithm was used which imposed additional constraints on the sparsity of the response. This was achieved through a sigmoid nonlinearity applied to the term in square brackets and by using a different function of \mathbf{y}^{S_i} following parameter ϑ . The above equation has been derived using Euler's method to convert the differential equation actually proposed by Rao and Ballard (1999) into a discrete time form suitable for numerical simulation. The dynamics of the original differential equation can be approximated to different degrees of precision by scaling parameters ζ , η , and ϑ to effectively modify the time step used.

Substituting for \mathbf{y}^{td} and rearranging the above equation, results in:

$$\mathbf{y}^{S_i} \leftarrow \mathbf{y}^{S_i} + \zeta \mathbf{W}^{S_i} \left[\mathbf{x} - (\mathbf{W}^{S_i})^T \mathbf{y}^{S_i} \right] - \eta \left[\mathbf{y}^{S_i} - (\mathbf{W}^{S_{i+1}})^T \mathbf{y}^{S_{i+1}} \right] - \vartheta \mathbf{y}^{S_i}$$

If we define \mathbf{e} to be a vector of error-detecting node activations, such that:

$$\mathbf{e}^{S_{i-1}} = \mathbf{y}^{S_{i-1}} - (\mathbf{W}^{S_i})^T \mathbf{y}^{S_i} \quad \text{and (equivalently)} \quad \mathbf{e}^{S_i} = \mathbf{y}^{S_i} - (\mathbf{W}^{S_{i+1}})^T \mathbf{y}^{S_{i+1}} \quad (2)$$

and set $\mathbf{y}^{S_{i-1}} = \mathbf{x}$ when $i = 1$, then the responses of the prediction nodes are given by:

$$\mathbf{y}^{S_i} \leftarrow (1 - \vartheta) \mathbf{y}^{S_i} + \zeta \mathbf{W}^{S_i} \mathbf{e}^{S_{i-1}} - \eta \mathbf{e}^{S_i} \quad (3)$$

The values of \mathbf{y} and \mathbf{e} are iteratively updated (while the input, \mathbf{x} , is held constant) in order to find the steady-state values for the node activations.

An illustration of a hierarchical neural network implementation of equations 2 and 3 is shown in Figure 1a. Only a simple, two stage, hierarchy is shown for clarity, but a practical model would include a convergence of connections from nodes with smaller non-overlapping receptive fields (RFs) in lower levels in order to provide nodes in higher levels with larger RFs. The neural implementation of the PC model employed by Rao and Ballard (1999) was more complicated than that shown in Figure 1a. In their implementation each cortical region contained four separate populations of neurons. However, the network shown in Figure 1a is equivalent to their model and retains its essential features such as excitatory feedforward connections, and inhibitory feedback connections, between different cortical regions, and feedforward excitation and feedback inhibition between the \mathbf{y} and \mathbf{e} populations within each cortical region. This network is also very similar to the architecture proposed by Friston (2005).

2.2 Reformulating Predictive Coding as Biased Competition

We can reformulate PC by substituting the definition of \mathbf{e}^{S_i} from equation 2 into the third term on the right-hand-side of equation 3 to yield the following equations for the updates to the error-detecting and prediction nodes:

$$\mathbf{e}^{S_{i-1}} = \mathbf{y}^{S_{i-1}} - (\mathbf{W}^{S_i})^T \mathbf{y}^{S_i}$$

$$\mathbf{y}^{S_i} \leftarrow (1 - \vartheta) \mathbf{y}^{S_i} + \zeta \mathbf{W}^{S_i} \mathbf{e}^{S_{i-1}} - \eta \mathbf{y}^{S_i} + \eta (\mathbf{W}^{S_{i+1}})^T \mathbf{y}^{S_{i+1}}$$

Furthermore, the different populations of error-detecting nodes can be re-labelled (by adding 1 to the processing stage each \mathbf{e} population is assigned to) without having any effect on functionality, such that:

$$\mathbf{e}^{S_i} = \mathbf{y}^{S_{i-1}} - (\mathbf{W}^{S_i})^T \mathbf{y}^{S_i} \quad (4)$$

$$\mathbf{y}^{S_i} \leftarrow (1 - \eta - \vartheta) \mathbf{y}^{S_i} + \zeta \mathbf{W}^{S_i} \mathbf{e}^{S_i} + \eta (\mathbf{W}^{S_{i+1}})^T \mathbf{y}^{S_{i+1}} \quad (5)$$

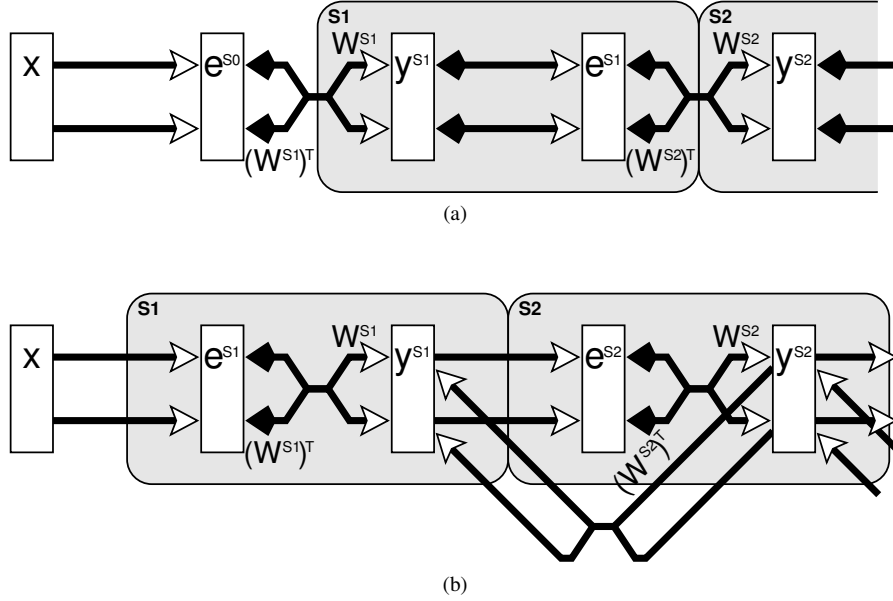

Figure 1: (a) A simplified diagram of the predictive coding model as implemented by [Rao and Ballard \(1999\)](#). (b) The predictive coding model reformulated as a form of biased competition model. Rectangles represent populations of neurons, with y labelling populations of prediction nodes and e labelling populations of error-detecting neurons. Open arrows signify excitatory connections, filled arrows indicate inhibitory connections, crossed connections signify a many-to-many connectivity pattern between nodes in two populations, parallel connections indicate a one-to-one mapping between the nodes in two populations, and large shaded boxes, with rounded corners, indicate the proposed mapping of the model onto different cortical areas or processing stages.

A neural network implementing equations 4 and 5 is shown in Figure 1b. The substitution of e^{S_i} into the equation for y^{S_i} has the effect of modifying the mechanism used to enable the activity in one population of y units to enhance the activity of nodes in the preceding population of y units. The original model employed a two stage inhibitory feedback pathway (via the e neurons) from the y population in one stage to that in the preceding stage. In contrast, the reformulated model produces a mathematically identical result using direct excitatory feedback from one population of prediction nodes to the preceding one. The re-labelling of the error-detecting nodes has the effect of shifting the assignment of neural populations to processing stages and hence changes the proposed mapping of the algorithm onto cortical regions (as illustrated by the large shaded boxes, with rounded corners, in Figure 1). The original PC network (Figure 1a) requires feedback from one cortical area to the preceding area to be predominantly inhibitory whereas the reformulated PC architecture (Figure 1b) predicts that the effects of cortical feedback are predominately excitatory. The latter is more consistent with cortical physiology ([Johnson and Burkhalter, 1997](#); [Shao and Burkhalter, 1996](#)) and hence the reformulated model proposes the more biologically plausible neural architecture.

Up to this point the model is mathematically identical to the linear model proposed by [Rao and Ballard \(1999\)](#): equations 4 and 5 are simply equation 1 re-written in a different form. However, in its current form this model only allows for a straight chain of processing stages, so that each stage receives feedforward input from one preceding stage and feedback from a single subsequent stage. To generalise the model so as to allow more complex hierarchies to be simulated, it is necessary to allow a processing stage to receive inputs from multiple sources. To allow multiple sources of feedforward input, it is simply necessary to replace $y^{S_{i-1}}$ in equation 4 with a column vector made of a concatenation of all the feedforward inputs to processing stage S_i . These inputs sources could be vectors of node activations calculated at lower-levels in the hierarchy and/or arrays of external inputs.

To allow multiple sources of feedback, equation 5 needs to be modified. In equation 5, feedback excitation received from each individual node in the subsequent stage in the hierarchy is summed to determine the overall top-down excitation received by a prediction node. Hence, feedback from all other possible sources should be treated in exactly the same way (*i.e.*, summed), so that:

$$y^{S_i} \leftarrow (1 - \eta - \vartheta)y^{S_i} + \zeta \mathbf{W}^{S_i} e^{S_i} + \eta \left[(\mathbf{W}^{S_{i+1}})^T y^{S_{i+1}} + (\mathbf{W}^{S_z})^T y^{S_z} + \dots \right]$$

Where the term in square brackets is simply the sum of the feedback received from each separate source of top-

down excitation. These feedback signals can originate from node activations calculated at higher-levels in the hierarchy and/or external inputs.

To include attention in the model, it is assumed that attentional feedback is treated exactly the same as feedback from higher stages in the hierarchy. Only one source of additional feedback to each modelled cortical region is assumed. Specifically, a processing stage (S_i) receives attentional feedback from a population of nodes with activations \mathbf{y}^{A_i} via a set of feedback weights $(\mathbf{W}^{A_i})^T$. These attentional signals are assumed to arise from circuitry not explicitly modelled here. For convenience, the above equation for \mathbf{y}^{S_i} is split into two separate equations, the first (equation 7) describing how prediction node activations change with bottom-up stimulation and the second equation (8) describing the top-down influences on the prediction node activations. This results in a final description of the linear model as follows:

$$\mathbf{e}^{S_i} = \mathbf{y}^{S_{i-1}} - (\mathbf{W}^{S_i})^T \mathbf{y}^{S_i} \quad (6)$$

$$\mathbf{y}^{S_i} \leftarrow (1 - \eta - \vartheta) \mathbf{y}^{S_i} + \zeta \mathbf{W}^{S_i} \mathbf{e}^{S_i} \quad (7)$$

$$\mathbf{y}^{S_i} \leftarrow \mathbf{y}^{S_i} + \eta \left[(\mathbf{W}^{S_{i+1}})^T \mathbf{y}^{S_{i+1}} + (\mathbf{W}^{A_i})^T \mathbf{y}^{A_i} \right] \quad (8)$$

The hierarchical neural network architecture that would implement equations 6, 7 and 8 is shown in Figure 2. This reformulated model can be interpreted as a form of BC model in which cortical regions at neighbouring stages along an information processing pathway are reciprocally connected by excitatory feedforward and feedback connections, and neurons (the \mathbf{y} population) within each population compete to be active. The outcome of this competition will be influenced by both the bottom-up stimulation received from earlier processing stages and the top-down activation received from higher-levels (including sources of attention). The type of competition used in this reformulated predictive coding model is very similar to that proposed by Harpur and Prager (1996, 1994), in which neurons within a region compete via a form of lateral inhibition in which nodes suppress the inputs (rather than the outputs) of other nodes. Specifically, activation from the prediction nodes is fed-back to subtractively inhibit the inputs to those nodes. This calculation of the inhibited input activities is performed in a separate neural population of error-detecting nodes. A similar mechanism of inhibition, in which nodes suppress the inputs to neighbouring nodes, has previously been used to successfully implement a BC model (Spratling and Johnson, 2004). However in this previous model, the inhibition was proposed to take place within the dendrites of the output neurons rather than within a separate, error-detecting population.

The model described by equations 6, 7 and 8 is mathematically identical to the linear PC model described by Rao and Ballard (1999) with a minor modification to allow external sources of attention to influence prediction node activities. As discussed in the preceding paragraph, this model can also be interpreted as a form of BC. It will, therefore, be referred to as the linear PC/BC model.

2.3 Introducing Nonlinearities

Up to this point the model is purely linear. In this section two changes to the model will be proposed, both of which introduce nonlinearities. The first modification is to change the mechanism of competition used by replacing equations 6 and 7 with:

$$\mathbf{e}^{S_i} = \mathbf{y}^{S_{i-1}} \oslash \left(\epsilon + (\hat{\mathbf{W}}^{S_i})^T \mathbf{y}^{S_i} \right) \quad (9)$$

$$\mathbf{y}^{S_i} \leftarrow (\epsilon + \mathbf{y}^{S_i}) \otimes \mathbf{W}^{S_i} \mathbf{e}^{S_i} \quad (10)$$

Where \mathbf{W}^{S_i} is a matrix of synaptic weight values normalised such that the sum of each row (*i.e.*, the total weight received by each node) is equal to one. $\hat{\mathbf{W}}^{S_i}$ is a matrix representing the same synaptic weight values as \mathbf{W} but such that the rows are normalised to have a maximum value of one. The parameter ϵ is a small constant (*i.e.*, 1×10^{-10}) that prevents division-by-zero errors in the calculation of \mathbf{e} and allows the values of \mathbf{y} to increase from an initial value of zero, and \oslash and \otimes indicate element-wise division and multiplication respectively.

The mechanism used in the linear PC/BC model applies subtractive inhibition to the inputs of the prediction nodes. The proposed method employs a mechanism of competition in which nodes divisively modulate their inputs. This is described as ‘divisive modulation’ of the inputs, rather than divisive inhibition, as the values of \mathbf{e} generated by equation 9 will often be larger than the corresponding \mathbf{x} value: the divisor of the division is not guaranteed to be larger than the dividend, and hence the inputs to the prediction nodes could be magnified as well as inhibited. This method is similar to an on-line version of the activation update rule used in the non-negative matrix factorisation algorithm (Lee and Seung, 1999) and has been shown to generate more accurate parsings of images into their elementary components than the subtractive feedback mechanism used in the linear model

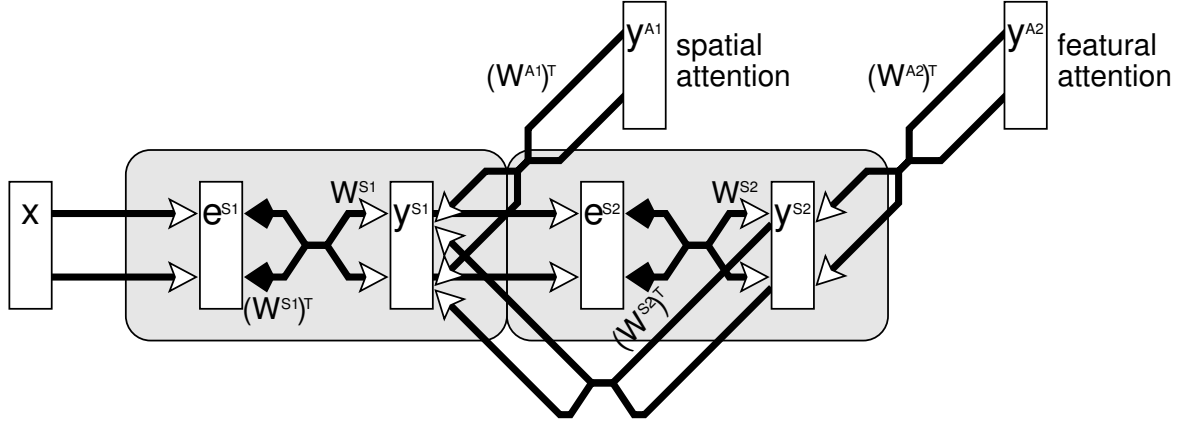

Figure 2: A simple, two stage, processing hierarchy used in the simulations reported in this article. The symbols used are the same as in Figure 1.

(Spratling et al., 2009). An additional advantage of this mechanism is that the values of e and y are inherently bounded to be non-negative. In contrast, in the linear PC/BC model both error-detecting and prediction nodes are required to be able to signal both positive and negative values. Since biological neurons have firing rates that can never be negative the proposed nonlinear mechanism of competition overcomes a biological implausibility of the linear model.

The second modification is to allow excitatory feedback from one processing stage to the preceding stage to be modulatory rather than additive; *i.e.*, to replace equation 8 with:

$$\mathbf{y}^{S_i} \leftarrow \mathbf{y}^{S_i} \otimes \left(1 + \eta \left[(\mathbf{W}^{S_{i+1}})^T \mathbf{y}^{S_{i+1}} + (\mathbf{W}^{A_i})^T \mathbf{y}^{A_i} \right] \right) \quad (11)$$

Cortical feedback has been observed to multiplicatively modulate the bottom-up driven activation of lower-level neurons (Andersen et al., 1985; Brotchie et al., 1995; McAdams and Maunsell, 1999; Motter, 1993; Treue, 2001; Williford and Maunsell, 2006). While these modulatory effects might be brought about by the interplay between linear mechanisms of excitation and inhibition (Reynolds and Chelazzi, 2004), several physiological mechanisms have been identified that could allow cortical feedback to have a direct modulatory effect on neural responses (Friston, 2005; Larkum et al., 2004; Spruston, 2008; Sripati and Johnson, 2006). Consideration of computational requirements have also lead to arguments in favour of cortical feedback being modulatory, rather than additive (Crick and Koch, 1998; Grossberg and Raizada, 2000; Roelfsema, 2006), for example, in order to avoid top-down expectation producing strong responses to stimuli for which there is no supporting evidence (*i.e.*, to prevent the “hallucination” of image features that are not present).

The model described by equations 9, 10 and 11 will be referred to as the nonlinear PC/BC model. This model can also be implemented using the neural architecture shown in Figure 2.

3 Results

To demonstrate that predictive coding can be used to model cortical biased competition both the linear PC/BC model (equations 6, 7 and 8) and the nonlinear PC/BC model (equations 9, 10 and 11) were used to simulate empirical data associated with attention. A simple two-stage hierarchy, as illustrated in Figure 2, was used in all simulations. These two processing stages are assumed to correspond to two neighbouring cortical regions along the ventral pathway. The lower region received input from a more peripheral cortical or thalamic region (that was not explicitly modelled) and each processing stage could receive attentional signals (also assumed to arise from circuitry not explicitly modelled here).

For experiments on spatial attention it was assumed that differential feedback would be received by ventral regions with RFs at an appropriate scale to define the attended region. Hence, attention to the spatial location occupied by one stimulus would preferentially enhance the response of the corresponding node representing that stimulus in the lower stage of the hierarchy. In contrast, for object-based attention it was assumed that feedback signals are received by nodes higher up the ventral pathway which are selective to the attended objects. Hence, attention to a feature is modelled by a top-down signal that enhances the response of a node encoding that feature in the second stage of the hierarchy.

3.1 Selective Attention

The first three experiments simulate the effects of selective attention (both spatial and featural) on the response properties of single cells. In each simulation, the neural populations in both the first and second processing stages contained only two nodes, and the input to the hierarchy came from two inputs (hence $n = m = 2$ for each processing stage). Similarly simple networks containing only a few nodes, employing different implementations of BC, have previously been used to simulate some of the same data modelled here (Deco and Rolls, 2005; Reynolds et al., 1999; Spratling and Johnson, 2004). In each experiment the response of one node in the upper region of the hierarchy was recorded (y_1^{S2}). This node received bottom-up stimulation (via the error-detecting nodes) from two prediction nodes in the preceding stage of the hierarchy. One of these lower-level prediction nodes provided strong stimulation to the recorded node, while the other provided weaker input. Hence, the recorded node could be strongly activated by a preferred stimulus and weakly activated by a poor stimulus.

The prediction nodes in the first stage of the hierarchy were assumed to have smaller, non-overlapping, RFs that were selective to two different input stimuli. The total synaptic weight received by each node was normalised to equal one. Hence, the weight matrix for the first stage was set to the identity matrix, *i.e.*, $\mathbf{W}^{S1} = \begin{pmatrix} 1 & 0 \\ 0 & 1 \end{pmatrix}$. Thus, one lower-level prediction node was exclusively selective to the preferred stimulus of the recorded, higher-level, prediction node while the other lower-level prediction node was activated by the poor stimulus for the recorded node. Since the mechanism of competition used here causes one node to inhibit an input to another node in proportion to the bottom-up weight received from that input by the inhibiting node, nodes in the first hierarchical stage did not compete because their afferent synaptic weights were non-overlapping. The weight matrix for the second processing stage had the form: $\mathbf{W}^{S2} = \begin{pmatrix} w_1 & 1 - w_1 \\ 1 - w_2 & w_2 \end{pmatrix}$. Where w_1 and w_2 were parameters to be fitted to the data.

Since the model was being used to simulate neurophysiological data collected from different cells with distinct selectivities, different sets of weight values were used in the different simulations. The weight values that provided the best fit to the experimental data were found by systematically varying w_1 and w_2 in the following ranges. For w_1 values of 0.6, 0.7, 0.8 and 0.9 were used. These values all exceed 0.5 since it is required that the recorded node be more responsive to the preferred stimulus than the poor stimulus. For w_2 values of 0.1, 0.3, 0.5, 0.7, and 0.9 were used. For each combination of weights the parameter η was also varied between 0.1 and 0.9 in steps of 0.2. Additionally, for the linear model the parameters ζ and ϑ were varied between 0 and 1 in steps of 0.25. An exhaustive search of all these possible parameter combinations was performed for each algorithm and parameters that provided a good subjective fit to the physiological data were chosen.

The two matrices of attentional weights were set to the identity matrix, *i.e.*, $\mathbf{W}^{A1} = \mathbf{W}^{A2} = \begin{pmatrix} 1 & 0 \\ 0 & 1 \end{pmatrix}$. All values in the the vectors \mathbf{y}^{A1} and \mathbf{y}^{A2} were set to zero except when simulating experimental conditions where attention was required, in which case the corresponding element in the vector \mathbf{y}^{A1} or \mathbf{y}^{A2} was set equal to one.

In all experiments, 20 iterations of the linear and nonlinear PC/BC models were performed for each experimental condition. The elements of \mathbf{x} (the sensory input) were set to a value of x or 0 to reflect the presence or absence of a stimulus. The value of x was set equal to the fractional Michelson contrast used for the presentation of stimuli in the corresponding empirical experiment, if this value was reported. A value of $x = 0.65$ was used in all other cases. The sensory input was reset to zero after 13 iterations, to simulate the offset of the stimuli used in the physiological experiments.

3.1.1 Spatial Selectivity

For neurons in the ventral pathway the response to a stimulus, that generates a strong response when presented in isolation, is reduced by the introduction of a second, non-preferred, stimulus within the RF (Reynolds et al., 1999). Hence, rather than being processed independently, multiple stimuli, within the same RF, appear to compete in a mutually suppressive manner (Kastner and Ungerleider, 2000). If attention is directed toward one stimulus then the response becomes more similar to the response that would be generated by that stimulus in isolation (Luck et al., 1997a; Moran and Desimone, 1985; Reynolds et al., 1999). Hence, attention appears to bias the competition in favour of the attended stimulus. These effects are illustrated in Figure 3a which shows the response of a single cell recorded in area V2. Similar results have been demonstrated for cells in area V4, inferior temporal cortex, in area MT of the dorsal pathway, and in prefrontal cortex (Everling et al., 2002; Moran and Desimone, 1985; Reynolds et al., 1999; Reynolds and Desimone, 1999; Treue and Martinez-Trujillo, 1999).

The firing rate of the cell is shown in response to a preferred stimulus, to a poor stimulus, and to both stimuli when attention is directed to a location outside the RF. When attention is directed to the location occupied by the preferred stimulus in the pair, the response of the cell becomes more similar to that elicited by the preferred

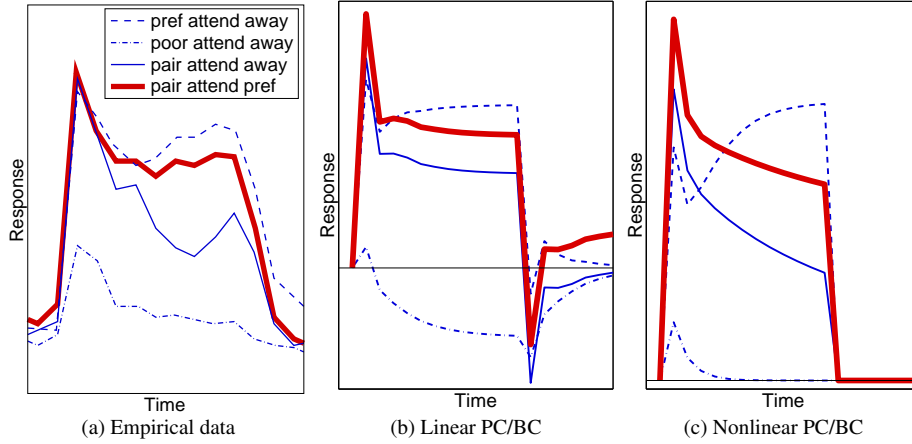

Figure 3: The effect of spatial attention on the response of a neuron. Responses are shown for different combinations of stimuli appearing within the RF of a single neuron. (a) The response of a cell in V2 (adapted from Reynolds et al., 1999). (b) Simulation results for the linear PC/BC model. (c) Simulation results for the nonlinear PC/BC model. For (a) the response was measured in spikes per second and time in milliseconds, for (b) and (c) response and time are in arbitrary units and have been scaled to resemble (a). The value of zero on the y-axis is indicated by the x-axis in (a) and by the thin horizontal lines in (b) and (c).

stimulus in isolation. Results for simulations with the linear PC/BC model and the nonlinear PC/BC model are shown in Figures 3b and 3c respectively. These results were obtained with parameters $w_1 = 0.9$, $w_2 = 0.5$, $\eta = 0.2$, $\zeta = 1$, and $\vartheta = 0$ for linear PC/BC, and $w_1 = 0.8$, $w_2 = 0.5$ and $\eta = 0.3$ for nonlinear PC/BC. The empirical data was recorded using stimuli presented at a Michelson contrast of 86%, hence, $x = 0.86$ was used for the stimuli presented to the model. The thin horizontal lines in Figures 3b and 3c indicate a response of zero. It can be seen that linear PC/BC allows negative responses. However, it is possible to clip the outputs of the prediction nodes at zero to prevent negative activities, and this has very little effect on the positive part of the graph shown in Figure 3b. It can be seen that both versions of the PC/BC model generate responses (after the initial transient response) that are qualitatively similar to those of the empirical data. In both cases, when the preferred stimulus of the recorded node was presented to the network, the recorded node quickly won the competition to respond to this stimulus and produced a high output. In contrast, when the poor stimulus was presented in isolation, the other node in the second processing stage won the competition and suppressed the response of the recorded node so that it generated a weak and brief output to its non-preferred stimulus. When both stimuli were present, both prediction nodes in the second processing stage were strongly activated and there was on-going competition between them which partially suppressed both responses. Hence, the response of the recorded node to the pair of stimuli was less than its response to its preferred stimulus in isolation. Attention to the preferred stimulus in the pair resulted in an enhanced response from the prediction node in the first processing stage which represents the preferred stimulus. This elevated feedforward activation in turn produced a stronger response from the recorded node in the second processing stage.

3.1.2 Spatial Selectivity and Contrast

The effect of attention in the previous simulation was to change the strength of the response of one of the prediction nodes in the first processing stage and hence to enhance the bottom-up activation received by the second processing stage. A similar effect could be achieved if the response of the node in the first stage was affected by changing the stimulus contrast. Hence, in the linear and nonlinear PC/BC models, a strong bottom-up signal could bias competition in just the same way as a top-down signal can. The interplay between attention and stimulus saliency has been explored experimentally (De Weerd et al., 1999; Kastner and Ungerleider, 2000; Martinez-Trujillo and Treue, 2002; Reynolds and Chelazzi, 2004; Reynolds and Desimone, 1999, 2003; Reynolds et al., 2000; Vecera, 2000).

One experiment investigating the interaction between stimulus contrast and spatial selective attention (Reynolds and Desimone, 2003) is very similar to that described in Section 3.1.1, but with the contrast of the poor stimulus being varied. Specifically, the firing rates of V4 cells were measured when a preferred and a poor stimulus were presented within the recorded cell's RF. The stimuli were presented individually and as a pair when attention was directed to a location outside the RF. The response to the pair of stimuli was also recorded when attention was

directed to the poor stimulus. The experiment was repeated for different poor stimulus contrasts (typically 5%, 10%, 20%, 40% and 80% Michelson contrast) but with a fixed contrast for the preferred stimulus (typical 40% Michelson contrast). The results are shown in Figure 4a.

It can be seen that, as the contrast of the poor stimulus increases (from left to right in Figure 4a), the response elicited by this stimulus in isolation increases. However, counter-intuitively, the response to the pair of stimuli decreases as the contrast of the poor stimulus increases. In other words, the suppression caused by the poor stimulus increases with contrast, when the pair of stimuli are presented, but the excitation of the poor stimulus increases with contrast, when it is presented in isolation. Attention to the poor stimulus has the effect of increasing the suppression of the response to the pair of stimuli. These results were simulated using the linear and nonlinear PC/BC models and the results are shown in Figures 4b and 4c. These results were obtained with parameters $w_1 = 0.9$, $w_2 = 0.6$, $\eta = 0.2$, $\zeta = 1$, and $\vartheta = 0$ for linear PC/BC, and $w_1 = 0.9$, $w_2 = 0.7$ and $\eta = 0.5$ for nonlinear PC/BC. It can be seen that the sustained responses generated by both models successfully accounts for the empirical data. Again, the negative responses of the linear model can be removed by simply taking the positive half-rectified values of the prediction node activations, with little impact on the positive portion of the response.

In both models, when the preferred stimulus of the recorded node is presented to the network, the recorded node quickly wins the competition to respond to this stimulus and produces a strong response. Since the contrast of the preferred stimulus was constant, the recorded response was the same in each experimental condition. In contrast, when the poor stimulus is presented in isolation, the other node in the second processing stage wins the competition and suppresses the activity of the recorded node so that it generates a weak and brief response to its non-preferred stimulus. The size of this brief response increases with the contrast of the poor stimulus as the bottom-up activation received by the recorded node, before it is inhibited by the other node, increases.

When both stimuli are present at high contrast, both prediction nodes in the second processing stage are strongly activated and there is on-going competition between them which partially suppresses both responses. Hence, the response of the recorded node to the pair of stimuli is less than its response to its preferred stimulus in isolation. However, when the poor stimulus is presented at low contrast, the activation of the second stage prediction node which represents the poor stimulus is weaker, and hence the suppression to the recorded node also weakens. At very low contrast, the bottom-up activation from the poor stimulus is so weak that it has very little effect on the responses of either node in the second processing stage and hence the recorded response becomes similar to that recorded when the preferred stimulus appears in isolation. Attention to the poor stimulus in the pair results in an enhanced response from the prediction node in the first processing stage which represents the poor stimulus. This elevated feedforward activation in turn produces a stronger response from the non-recorded node in the second processing stage. This node can therefore more strongly inhibit the recorded node's response, and hence the suppressive effect of the poor stimulus is enhanced by attention.

A second counter-intuitive result from the empirical data is that a node which is more selective for the preferred stimulus (*i.e.*, a node that generates a weaker response to the poor stimulus in isolation) is subject to a greater suppression in its response to the preferred stimulus when this is presented together with the poor stimulus (Reynolds and Desimone, 2003). In other words, the poorer the poor stimulus the weaker the response elicited by the pair of stimuli. Both the linear and nonlinear PC/BC models also show this effect. Response histograms for a population of V4 cells that were highly selective to the preferred stimulus are shown in Figure 4a and the simulations of this data are shown in Figure 4b and 4c. Reynolds and Desimone (2003) also analysed a second population of less selective cells (however, response histograms of this data were not produced). This less selective population was modelled by reducing the value of the parameter w_1 to make the recorded node less selective for the preferred stimulus. Figure 4d shows results for the linear model with $w_1 = 0.7$ and Figure 4e shows this result for the nonlinear model with $w_1 = 0.7$. All other parameters were unchanged in both cases. Comparing Figure 4d with Figure 4b and Figure 4e with Figure 4c it can be seen that the suppression due to the poor stimulus (at high contrasts) is increased when the recorded node is highly selective.

Two effects give rise to this result. Firstly, because the synaptic weight from the preferred input is larger the response to the preferred stimulus in isolation is enhanced resulting in suppression becoming greater when the poor stimulus is present relative to the preferred stimulus in isolation (this effect is most pronounced in the nonlinear model). Secondly, the response to the pair of stimuli is decreased in absolute terms between medium and highly selective nodes. The reduction in response to the pair of stimuli is a result of the competition between the recorded node and the other node in the second processing stage. As the recorded node becomes more selective to one stimulus, it becomes a poorer representation of the pair of stimuli. The other node, which does provide a good representation of the pair, thus wins the competition more quickly and more rapidly suppresses the activation of the recorded node. This effect is due to the particular form of competition used in the PC/BC model, in which nodes compete to receive inputs rather than to generate outputs. This enables patterns of pre-synaptic activity to be parsed into accurate representations, even when those representations overlap (Harpur and Prager, 1996, 1994; Spratling et al., 2009; Spratling and Johnson, 2001, 2002, 2003). It can also be seen that, in the low selectivity

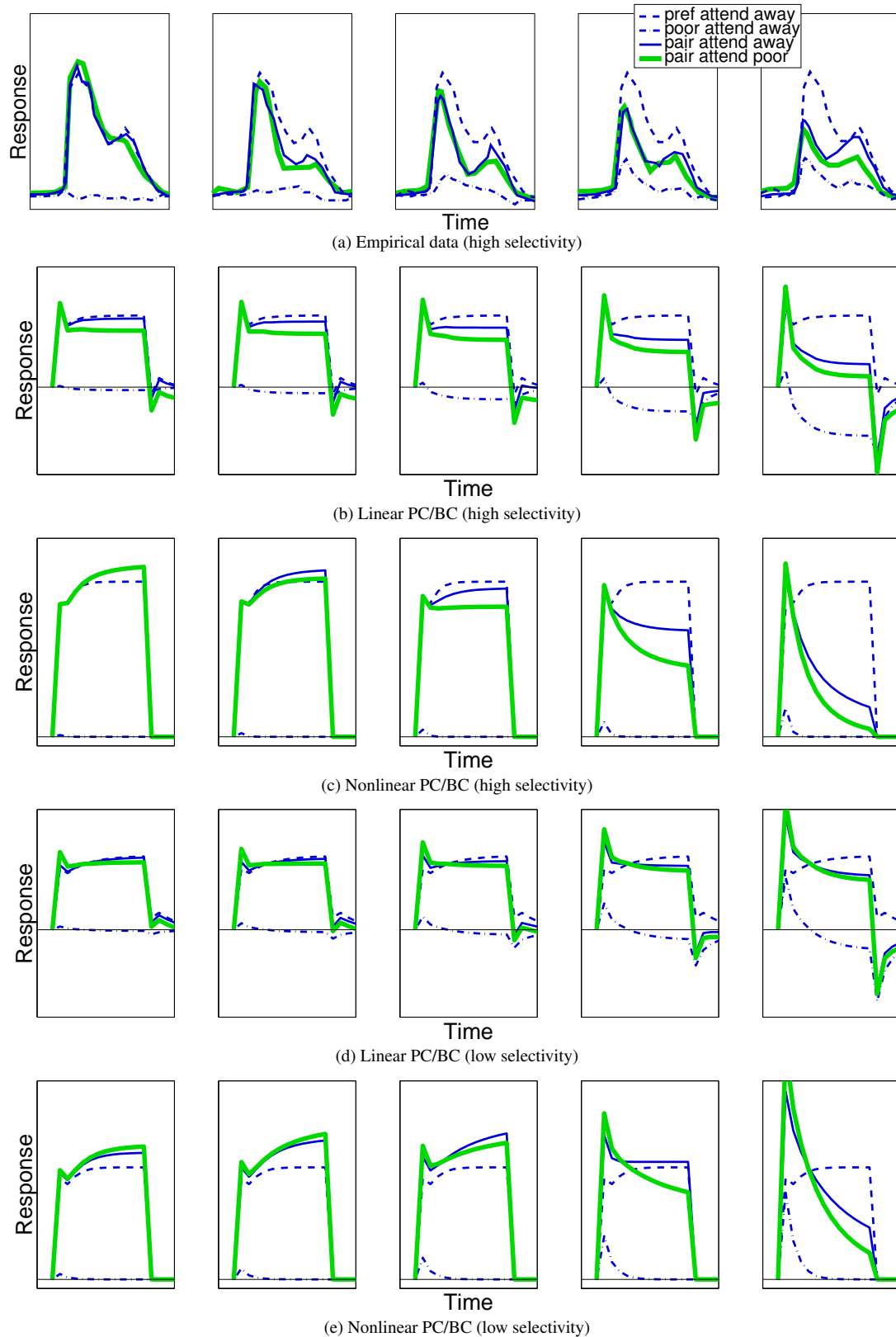

Figure 4: The effect of changing contrast and spatial attention on the response of a neuron. Responses are shown for different combinations of stimuli appearing within the RF of a neuron. Plots from left to right show responses for increasing contrast of the poor stimulus. (a) The averaged response for a population of cells in V4 (adapted from Reynolds and Desimone, 2003). (b) Simulation results for the linear PC/BC model. (c) Simulation results for the nonlinear PC/BC model. Additional simulation results are shown for when the selectivity of the recorded node was reduced in (d) the linear PC/BC model, and (e) the nonlinear PC/BC model. Plots have been scaled as described in the caption to Figure 3, but additionally, all plots in (b) and (d), and plots in (c) and (e) are scaled identically to aid comparison. The value of zero on the y-axis is indicated by the x-axis in the plots of the empirical data and by the thin horizontal lines in the plots of the simulation results.

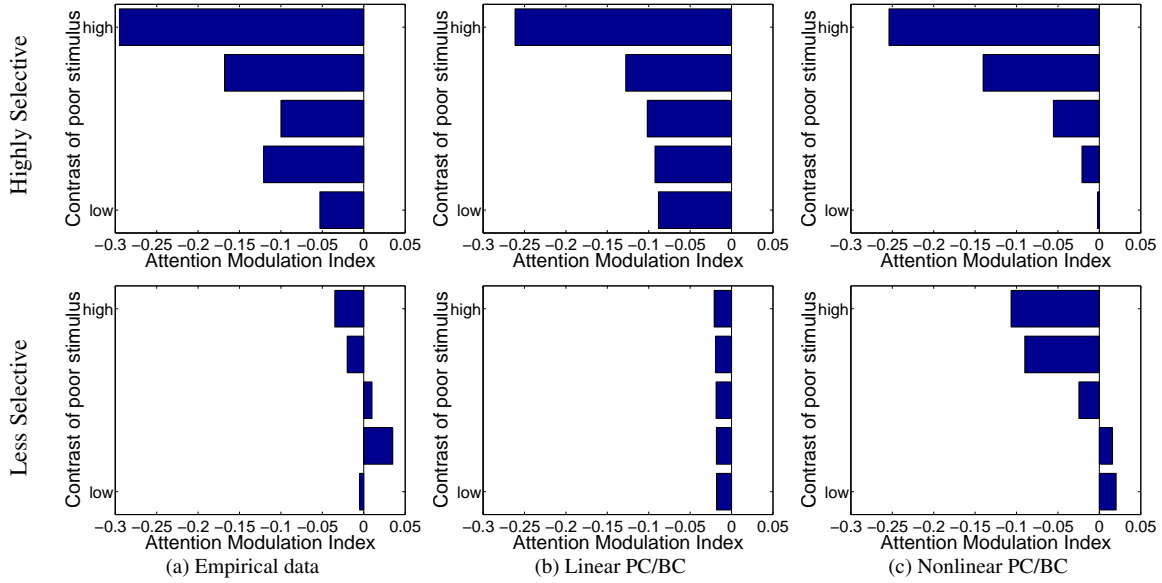

Figure 5: Quantitative data showing the effect of spatial attention with changing contrast. Each sub-plot shows values of the attention modulation index (AMI) for varying poor stimulus contrasts. The top row shows the results when neurons are highly selective to the preferred stimulus, and the bottom row shows results for neurons which are less selective to the preferred stimulus. Column (a) shows the average AMI values for a population of cells in V4 (Reynolds and Desimone, 2003). Column (b) shows simulation results for the linear PC/BC model. Column (c) shows simulation results for the nonlinear PC/BC model.

case, (Figure 4d and Figure 4e) attention to the poor stimulus causes little additional suppression of the response to the pair, but in the high selectivity case (Figure 4b and Figure 4c), attention to the poor stimulus causes additional suppression to the response to the pair. This is also consistent with the empirical data (Reynolds and Desimone, 2003).

As well as providing a good qualitative fit to the data, both models also provide a good quantitative fit. Reynolds and Desimone (2003) report the response, averaged over time, generated by the preferred stimulus presented in isolation and the average response generated by the pair of stimuli when presented at equal contrasts. In the population of cells that are highly selective for the preferred stimulus the response to the preferred stimulus is 46% higher than the response to the pair (29.5 spikes/s compared to 20.2 spikes/s). In the low selectivity population these average responses are much more similar (39.3 spikes/s compared to 36.5 spikes/s). In the linear model, when the recorded node has high selectivity the response to the preferred stimulus is 45% higher than the response to the pair (0.32 compared to 0.22), whereas the responses are similar when the recorded node has low selectivity (0.32 compared to 0.30). In the nonlinear model, the response to the preferred stimulus is 39% higher than the response to the pair in the high selectivity case (0.43 compared to 0.31) whereas these responses are similar in the low selectivity case (0.31 compared to 0.33). The average responses in the simulations were recorded from the first iteration following the transient response (iteration 4) until the offset of the stimulus (iteration 13).

Reynolds and Desimone (2003) also report the size of the attentional effect, in terms of an attentional modulation index (AMI), for both the high and low selectivity populations across all poor stimulus contrasts. The AMI is calculated as $\frac{R_{pp} - R_{pa}}{R_{pp} + R_{pa}}$, where R_{pp} is the time averaged response to the pair of stimuli when attention is directed to the poor stimulus, and R_{pa} is the time averaged response to the pair of stimuli when attention is directed away. The spike counts for the V4 cells were averaged over the same time interval as that used to calculate the average responses reported in the previous paragraph. The same time interval, as used previously, was therefore also used to calculate the AMI values for the simulated data. The AMI values averaged across the high and low selectivity sub-populations of V4 cells are shown in Figure 5a. The AMI values calculated from the simulations are shown in Figure 5b for the linear model, and Figure 5c for the nonlinear model. It can be seen that there is good agreement between both models and the empirical results.

3.1.3 Featural Selectivity

Rather than specifying the spatial location that is to be attended, it is also possible to experiment with the effects of cueing the target object that is to be attended. One such experiment (Chelazzi et al., 2001) presented an array containing one or two objects, one of which might have previously been cued as the target for a saccade. Responses

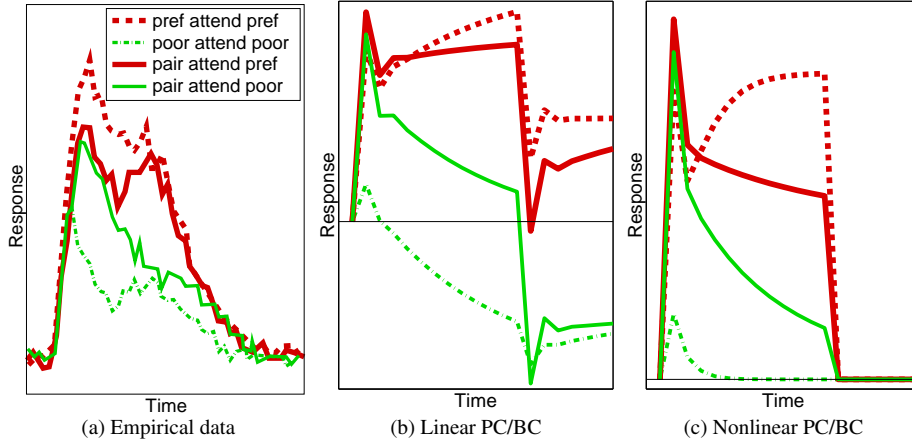

Figure 6: The effect of featural attention on the response of a neuron. Responses are shown for different combinations of stimuli appearing within the RF of a single neuron. (a) The averaged response for a population of cells in V4 (adapted from Chelazzi et al., 2001). (b) Simulation results from the linear PC/BC model. (c) Simulation results from the nonlinear PC/BC model. For (a) the response was measured in spikes per second and time in milliseconds, for (b) and (c) response and time are in arbitrary units and have been scaled to resemble (a). The value of zero on the y-axis is indicated by the x-axis in (a) and by the thin horizontal lines in (b) and (c).

were measured from cells in area V4, with RFs sufficiently large to encompass the stimulus array. Different responses were generated when the target object was the preferred stimulus of the recorded cell compared to when the target was a non-optimal stimulus (see Figure 6a). Results are similar to those for attentional selection using spatial cues (Section 3.1.1) in that when the stimulus array contains a pair of objects the response of the cell becomes more similar to the response that would be generated by the attended stimulus in isolation.

The simulation results for this experiment are shown in Figures 6b and 6c. These results were obtained with parameters $w_1 = 0.8$, $w_2 = 0.3$, $\eta = 0.1$, $\zeta = 1$, and $\vartheta = 0$ for linear PC/BC, and $w_1 = 0.8$, $w_2 = 0.5$ and $\eta = 0.1$ for nonlinear PC/BC. Following the initial transient response, both models provide a qualitative fit to the experimental data (if the negative response in the linear model are ignored). In the previous simulations, attention targeted the first processing stage in the hierarchy. In this simulation, attentional signals provided top-down bias to nodes in the second processing stage.

When a single stimulus is presented to the network the node in the second processing stage with the preference to that stimulus wins the competition and inhibits the other node from generating an output. Hence, the recorded node wins the competition for its preferred stimulus and generates a strong response, but loses the competition to represent the poor stimulus and has its response suppressed. When both stimuli are presented, there is ongoing competition between the two nodes in the second processing stage. This partially suppresses the response of both nodes. However, if attention is directed to the recorded node, this enhances the response of the recorded node and overcomes some of the suppression due to competition. In contrast, when attention targets the other node in the second processing stage, this node has its response elevated which results in the response of the recorded node being more strongly suppressed via competition.

3.2 Attention and Tuning

The next two experiments simulate the effects attention on the tuning response functions of single cells. As in the previous experiments a two-stage model (as illustrated in Figure 2) was employed. Also, as in previous simulations, the matrix \mathbf{W}^{S1} was made equal to the identity matrix, so that nodes in the first processing stage effectively had non-overlapping RFs, and two matrices of attentional weights (\mathbf{W}^{A1} and \mathbf{W}^{A2}) were also set equal to the identity matrix so that attentional biases could be selectively directed to individual nodes. All values in the the vectors \mathbf{y}^{A1} and \mathbf{y}^{A2} were set to zero except when simulating experimental conditions when attention was required. As previously, experiments concerning spatial attention, used feedback targeting the prediction nodes in the first stage, while experiments on featural attention employed attentional signals targeting the second processing stage. Parameter values were set equal to the median values of those found to provide the best fits to the experimental data modelled in Section 3.1 (i.e., $\eta = 0.2$, $\zeta = 1$, $\vartheta = 0$ for the linear model, and $\eta = 0.3$ for the nonlinear model).

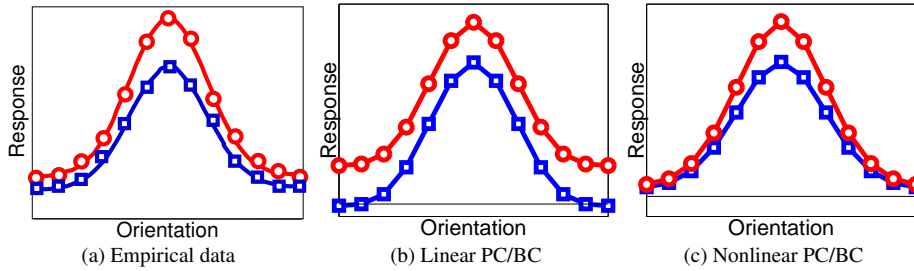

Figure 7: The effect of spatial attention on the tuning response function of a neuron. Response strength is shown for varying stimulus orientation when attention is directed to the location occupied by the stimulus (circular markers) and when attention is directed away from the stimulus (square markers). (a) Experimental results (adapted from [McAdams and Maunsell, 1999](#)) showing the average tuning curve measured in V4. Simulation results for (b) the linear PC/BC model and (c) the nonlinear PC/BC model. The x-axis in (a) corresponds to the spontaneous response level of the recorded cells, the thin horizontal lines in (b) and (c) corresponds to a response of zero in the simulation.

In contrast to previous simulations, each prediction node in the second processing stage received a set of synaptic weights that had a Gaussian profile. Nodes in the first stage were assumed to represent either a stimulus orientation or a direction of motion. Hence, each second stage node had a preferred orientation/direction but was broadly tuned to a range of inputs. Nine nodes, with different preferred inputs, were used in the second processing stage so that the preferred inputs were equally distributed between 0 and 180° in the case of orientation preference, and 0 and 360° in the case of direction of motion preference. The input stimulation (\mathbf{x}) received by the first processing stage also had a Gaussian profile. The variance of the input and the weights were tuned separately for the linear and nonlinear models to obtain a good fit to the empirical data.

3.2.1 Spatial Facilitation and Tuning

The effects of spatial attention on the orientation tuning of cells in areas V1 and V4 was investigated by [McAdams and Maunsell \(1999\)](#). In this experiment a single orientation grating was presented within the RF of the recorded cell. It was found that when attention was directed to the location of the orientation grating the cell's response was enhanced compared to when attention was directed to a different location. By varying the orientation of the stimulus relative to the recorded cell's preferred orientation, tuning curves were generated for both the attended and non-attended conditions (see Figure 7a). The effect of attention was a multiplicative scaling of the tuning response function.

To simulate this experiment, the response of one node in the second processing stage was measured to varying input orientations, both with and without attention. In the attended condition all nodes in the first processing stage received equal top-down activation (*i.e.*, all values in the vector \mathbf{y}^{A1} were made equal to one). This means that attention was feature independent (*i.e.*, spatial) as it targeted equally all the nodes in the first processing stage. Results for the linear and nonlinear PC/BC model are shown in Figure 7b and 7c respectively. It can be seen that in the linear model attention produces an upward translation of the orientation tuning curve. This is due to each prediction node in the first processing stage receiving an equal, additive, top-down excitation that is fed-forward to equally enhance the response of the recorded node irrespective of the orientation of the stimulus. In contrast, the nonlinear model produces a result similar to the empirical data. This is due to the multiplicative effect of the top-down input to the prediction nodes in the first processing stage, which means that the feedforward excitation received by the recorded node is enhanced in proportion to the match between the orientation of the stimulus and the preferred orientation of the node. Note that the model does not simulate spontaneous neural activity and hence at the null orientation the response of the recorded node approaches zero. In contrast, the neural response in the physiological data remains above zero and this spontaneous activity is multiplicatively modulated by attention.

3.2.2 Featural Facilitation and Tuning

A similar experiment was performed by [Martinez-Trujillo and Treue \(2004\)](#) to determine the effects of featural attention on the direction of motion tuning of cells in areas MT. In this experiment a single moving random dot pattern was presented within the RF of the recorded cell. By varying the direction of motion of the stimulus relative to the recorded cell's preferred direction, tuning curves were generated for two attentional conditions. In the first condition, attention was directed to a stationary fixation point outside the RF of the recorded neuron (*i.e.*,

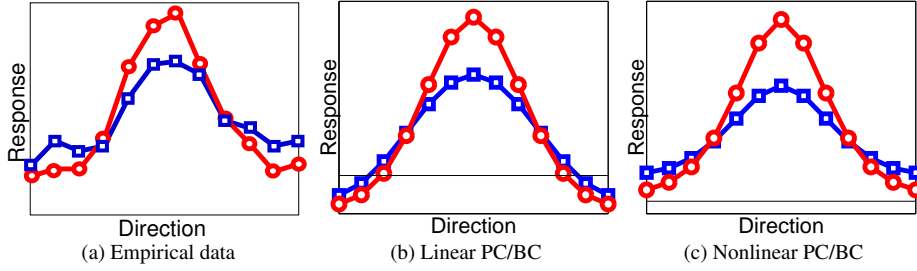

Figure 8: The effect of featural attention on the tuning response function of a neuron. Responses are shown for varying directions of motion when attending the same direction of motion as the stimulus (circular markers) and when attending a stationary fixation point (square markers). (a) Experimental results (adapted from [Martinez-Trujillo and Treue, 2004](#)) showing the response of an MT neuron. Simulation results for (b) the linear PC/BC model and (c) the nonlinear PC/BC model. The value of zero on the y-axis is indicated by the x-axis in (a) and by the thin horizontal lines in (b) and (c).

direction of motion was ignored). In the second condition attention was directed to a second moving random dot pattern outside the RF of the recorded neuron which had the same direction of motion as the pattern within the recorded cell’s RF (*i.e.*, attention was directed to the same direction of motion as the stimulus). It was found that attention caused an enhancement of the cell’s response when the direction of motion was close to the preferred direction for the cell, but a suppression of response when the direction of the stimulus (and hence the attended direction) was far from the cell’s preferred direction (see Figure 8a).

To simulate this experiment, the response of one node in the second processing stage was measured to varying input directions, both with and without attention. In the attended condition nodes in the second processing stage received top-down activation that had a Gaussian profile centred on the direction of motion of the input stimulus. Results for the linear and nonlinear PC/BC model are shown in Figure 8b and 8c respectively. It can be seen that both versions of the model simulate the multiplicative response enhancement that occurs for directions of motion similar to the preferred direction of motion for the recorded node. This is because the attentional signal received by the recorded node in the second processing stage increases in proportion to the match between the attended direction and the preferred direction of the node. Furthermore, both the linear and nonlinear models show response suppression when the direction of motion is dissimilar to the preferred direction. This is caused by the competition that occurs between the prediction nodes in the second processing stage. When the input stimulus is dissimilar to the preferred stimulus of the recorded node, it is more similar to the preferred input of other nodes. These other nodes win the competition and suppress the input received by the recorded node, reducing its response. When featural attention enhances the response of the winning node, this results in an even greater suppression of the recorded node’s response.

3.3 Attention and Behaviour

The effects of attention have also been extensively studied using behavioural measures. A particularly influential experimental procedure ([Posner, 1980](#)) employs a cue to direct covert attention to one of two spatial locations where a subsequently presented target is most likely to appear. Numerous variations on this paradigm (*e.g.*, [Posner, 1980](#); [Vossel et al., 2006](#); [Wright et al., 1995](#)) show the same pattern of results: faster reaction times when the cue is valid meaning that the target appears at the cued location, and slower reaction times when the cue is invalid so that the target appears at the uncued location. Furthermore, the strength of the effect is dependent on the proportion of trials for which the cue is valid ([Vossel et al., 2006](#)). Typical reaction time data are shown in Figure 9a for an experiment in which participants had to detect the onset of the target (irrespective of location) following a central cue .

The PC/BC model was used to provide a very simple simulation of this experiment. The first processing stage consisted of two prediction nodes, with non-overlapping RFs (*i.e.*, \mathbf{W}^{S1} was a 2 by 2 identity matrix). These nodes acted as feature detectors for the target stimulus at the two locations. Both prediction nodes in the first processing stage provided input to a second processing stage that contained only a single prediction node ($\mathbf{W}^{S2} = [0.5, 0.5]$). This node responded (equally, in the absence of top-down bias) to the target at either location. Reaction time was presumed to be inversely proportional to the strength of the response of the prediction node in the second processing stage (*i.e.*, simulated reaction time = $1 - y_1^{S2}$). This is equivalent to using the ‘race’ model of decision making. Attention was directed to the prediction nodes in the first processing stage (\mathbf{W}^{A1} was an identity matrix). This is consistent with empirical data suggesting that the attentional cue enhances early sensory

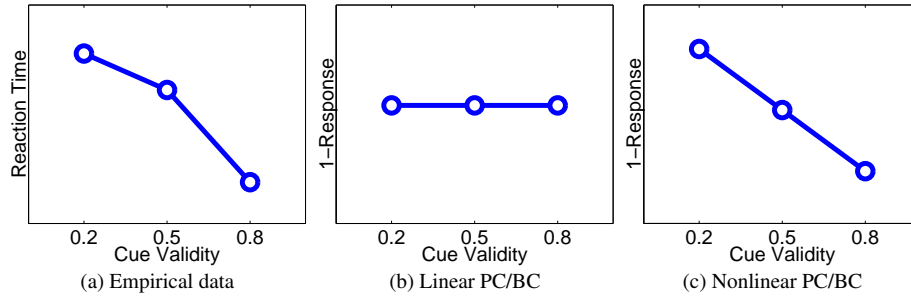

Figure 9: The effect of spatial attention on reaction time. (a) Experimental results (from Wright et al., 1995) showing the mean reaction times as a function of cue validity. Simulation results for (b) the linear PC/BC model and (c) the nonlinear PC/BC model.

processing (Wright et al., 1995). The strength of the attention signal was made equal to the prior probability that the target would appear at each location. Hence, in an experiment in which the cue accurately predicted the location of the target on 80% of trials, and the cue pointed to location 1, then $\mathbf{y}^{A1} = [0.8, 0.2]^T$. All parameter values were identical to those used in the Section 3.2. Results from the simulation are shown in Figure 9b for the linear model, and Figure 9c for the nonlinear model.

It can be seen that for the linear PC/BC model, the reaction time is constant in all conditions. This is due to the prediction nodes in the first processing stage receiving additive top-down stimulation from the attention signals. The total top-down activation received by the two nodes in the first processing stage is equal in each condition, and hence the total feedforward activation received by the prediction node in the second processing stage is constant. In contrast, the nonlinear PC/BC model is able to simulate the empirical data. In this case the attentional feedback is modulatory and hence it only affects the activation of one node in the first processing stage corresponding to the location where the target appears. If this location was cued, then the attention signal will strongly enhance the response of this node and hence increase the feedforward activation sent to the prediction node in the second processing stage. In contrast, if the location where the target appears was not cued, attention will only weakly enhance the response of the node in the first processing stage, resulting in less feedforward stimulation of the second processing stage.

3.4 Feature Binding

Selective attention has been proposed to play an important role in solving the binding problem (Luck and Ford, 1998; Luck et al., 1997b; Reynolds and Desimone, 1999; Treisman, 1998; Treisman and Gelade, 1980), particularly in resolving the ambiguous assignment of features to objects when multiple stimuli are processed simultaneously (Luck et al., 1997b).

The empirical data described in the previous sections (particularly for selective attention, Section 3.1) demonstrates that the responses of cortical neurons are dominated by the attended (or most salient) stimulus within their RFs and, hence, that attended (or salient) information is preferentially selected for transmission to subsequent cortical regions for further processing. The BC hypothesis proposes that this selection of relevant information is achieved via competition between neurons representing attended and non-attended stimuli. Neurons which represent the attended (or most salient) stimulus receive enhanced activation from top-down attention signals (or salient, bottom-up, stimulus attributes). This enhanced activation biases these neurons to succeed in the competition to be active, and enables these neurons to inhibit other cells that do not represent the attended (or salient) stimulus. Hence, information about the attended (or most salient) stimulus is more strongly represented and transmitted to subsequent processing stages. Even if the competition does not lead to the complete suppression of neural responses encoding irrelevant information, the enhancement to the firing rate of neurons encoding the attended stimulus will cause them to be preferentially processed and can be seen as a ‘label’ for relevant information (Roelfsema, 2006; Roelfsema et al., 2000).

3.4.1 Binding Feature Conjunctions via Featural Attention

A particular form of binding problem occurs when multiple stimuli are simultaneously presented and it is necessary to determine which features belong to which object (Luck et al., 1997b; Treisman, 1996). Specifically, if separate features of the visual environment are encoded by different neurons, then when several of these neurons are active concurrently it is necessary to determine which of the represented features are attributes of one

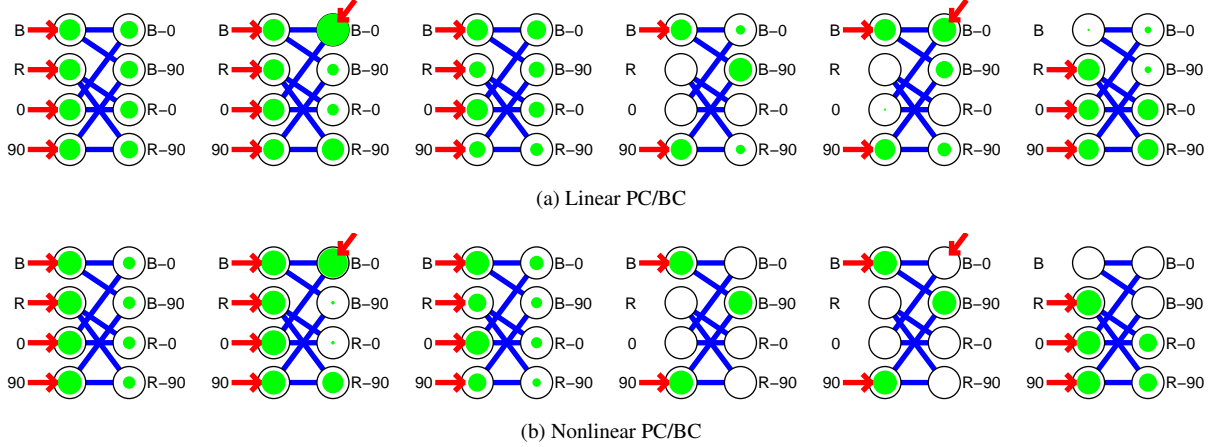

Figure 10: The effects of selective object-based attention on feature binding in a simple task simulated with (a) the linear PC/BC model, and (b) the nonlinear PC/BC model. Each subplot shows the responses of the prediction nodes in the first and second processing stages to different combinations of input stimuli and attentional states. The strength of each node’s response (at the end of 20 iterations) is indicated by the diameter of the shading. Four prediction nodes in the first processing stage represent independent features of the input stimulus. The four prediction nodes in the second processing stage represent pairwise *conjunctions* of the features represented in the first stage. Connections between the processing stages correspond to the synaptic weights in \mathbf{W}^{S2} and hence show the weights received by the prediction nodes in the second stage from the outputs of prediction nodes in the first stage via the error-detecting nodes (not shown). The connections also indicate the feedback weights received by the prediction nodes in the first stage from the prediction nodes in the second stage. Horizontal arrows indicate which nodes receive bottom-up stimulation, while arrows oriented diagonally indicate nodes that receive attentional input. Note that for each condition, the external inputs to both models are identical. The difference between (a) and (b) in the activities of the prediction nodes in the first processing stage is a result of the different effects of top-down bias between the two models.

object, and which are attributes of other objects. For example, if neurons encoding the colours blue and red, and the orientations 0 and 90 are all simultaneously active, is this due to the presentation of a red-vertical line and a blue-horizontal line or to a red-horizontal line and a blue-vertical line (Rosenblatt, 1961; Thorpe, 1995; von der Malsburg, 1995)?

The PC/BC model can be used to simulate this ambiguous situation. The parameters used were the median values of those found to provide the best fits to the data modelled in Section 3.1 and hence the same as the parameters used in the simulations described in Sections 3.2 and 3.3. Four nodes in the first processing stage were used to represent the individual features blue (‘B’), red (‘R’), horizontal (‘0’) and vertical (‘90’), while four nodes in the second processing stage each received inputs from a different combination of two nodes in the lower level so that they represented the conjunctions blue-horizontal (‘B-0’), blue-vertical (‘B-90’), red-horizontal (‘R-0’), and red-vertical (‘R-90’). For both the linear and nonlinear versions of the model, when every node in the first processing stage received bottom-up stimulation, all the nodes in the second stage became partially, and equally, active (Figure 10 first column). The nodes were more weakly active than the winning node when the input was unambiguous (*i.e.*, when it consisted of only one colour and one orientation feature, as in the fourth column of Figure 10). For the linear model, nodes in the ambiguous case were active with 75% of the strength of the winning node in the unambiguous case. In the nonlinear model, nodes in the ambiguous case were active with 50% of the strength of the winning node in the unambiguous case. This behaviour could be interpreted in probabilistic terms as saying that each conjunction is predicted to be present in the input with a probability less than in the unambiguous case. The nonlinear model correctly divides the probability in half.

Attentional feedback can resolve the ambiguity in the sensory data by providing bias for one possible interpretation over all others. For example, if attention targets the node in the second processing stage that represents ‘B-0’ then this will enhance this node’s activation and cause it to be most active (Figure 10 second column). Furthermore, due to the form of competition used in the model, enhancing the activation of node ‘B-0’ will cause it to more strongly inhibit the inputs received by other second stage nodes from features ‘B’ and ‘0’. This will reduce the response of nodes representing overlapping conjunctions (*i.e.*, ‘B-90’ and ‘R-0’) but it will not inhibit the inputs to node ‘R-90’. Hence, top-down bias in favour of one conjunction of features will also cause a strong

response from the node representing the complementary conjunction, and hence both nodes compatible with the biased interpretation produce a strong response (*i.e.*, binding together blue and horizontal also results in red and vertical being bound).

Rather than using attention to resolve the ambiguity, it is also possible to bias the competition using bottom-up factors. If the second stage node representing ‘B-0’ had stronger weights than the other nodes (perhaps due to more prior experience with this conjunction having lead, via activity-dependent learning, to a more selective representation), then this will lead to ‘B-0’ winning the competition due to it receiving stronger bottom-up stimulation. Similarly, if the features ‘B’ and ‘0’ are presented at a higher contrast, then this will lead to the node representing this conjunction receiving stronger feedforward activation and hence being the most active node (see Figure 10 column 3). In this particular example, inputs ‘B’ and ‘0’ are 30% stronger than inputs ‘R’ and ‘90’. This leads to the node representing the conjunction ‘B-0’ having a response that is 22% higher than any other node in the linear model, and a response 32% higher in the nonlinear model.

The conditions shown in the fifth and sixth column of Figure 10 illustrate limitations of the linear PC/BC model. Firstly, when attention is directed to an object that is not present in the input, then this can lead to the wrong parsing being generated. In this example, the input is unambiguous consisting of only one colour (‘B’) and one orientation (‘90’). Without attention this is represented by the appropriate node in the second processing stage (Figure 10 fourth column). When attention is directed to the second stage node that represents the conjunction ‘B-0’ (Figure 10 fifth column), this has no effect in the nonlinear model, but results in the attended node producing the strongest response in the linear model. The additive feedback in the linear model causes attention to be able to ‘hallucinate’ objects that are not present in the input. In contrast, the multiplicative feedback used in the nonlinear model only allows attention to enhance the responses of neurons that are driven by bottom-up activation.

The sixth column of Figure 10 illustrates a situation where multiple objects sharing a feature are present in the input (*e.g.*, two red bars, one with an orientation of 0 degrees and the other at 90 degrees). The nonlinear PC/BC model resolves the competition between the nodes in the second processing stage so that the nodes representing the conjunctions ‘R-0’ and ‘R-90’ are active, while the activations of the nodes representing the conjunctions ‘B-0’ and ‘B-90’ are completely suppressed. In contrast, the subtractive competition used in the linear PC/BC model allows the representations of ‘B-0’ and ‘B-90’ to remain partially active. This leads to instability as the number of features increases. For example, in a network that represents 10 orientations rather than two, when all orientations are present in the input, all node activations in the second processing stage of the linear model become large (> 500 after 20 iterations) and continue to increase in value as the number of iterations is increased, or if the model is expanded to include more features. This instability is due to the increasingly strong feedback received by the nodes in the first processing stage as the number of conjunctions they are involved in increases. For 10 orientations each error-detecting node in the second stage receives feedback from 10 conjunctive nodes. This feedback is summed up and subtracted from the input to the second stage, resulting in negative activation values for the error-detecting nodes. These negative error values generate negative predictions at the next iteration, which in turn are fed-back to be subtracted from the error; generating positive error values which in turn produce positive prediction values. This oscillatory behaviour continues with the amplitude of the oscillation getting bigger at each iteration. In contrast, the nonlinear PC/BC model does not suffer instability. A large number of feature combination produces strong feedback, as in the linear model. However, the divisive input modulation causes the error-detecting node activations to be reduced which in turn scales the strength of the activations of the prediction nodes and keeps them at low values.

3.4.2 Binding Feature Disjunctions via Spatial Attention

The previous experiment explores the problem of binding features into conjunctions in order to form more specialised representations (“property binding” (Treisman, 1996)). The binding problem also arises when forming disjunctions of features in order to generate a representation that is more invariant to viewpoint (“location binding” (Treisman, 1996)). To illustrate this alternative form of binding problem consider a situation where two populations of neurons code for the same set of features but at different spatial locations (*e.g.*, one set of nodes represents features ‘B’, ‘R’, ‘0’, and ‘90’ at location ‘L1’, and another set of nodes represent the same features appearing at location ‘L2’). If a subsequent processing stage responds to these features with invariance to location, then a prediction node in the second processing stage will receive excitation (via the error-detecting nodes) from both prediction nodes in the first processing stage that represent that feature. However, if the stimulus containing the features ‘R’ and ‘0’ is presented to the network at location ‘L1’ and the features ‘B’ and ‘90’ are present at location ‘L2’ this will result in equal activation of all the nodes in the second stage. This is true for both the linear and nonlinear versions of the PC/BC model, as shown in the first column of Figures 11a and 11b. Note this would be the case whether the pre-synaptic activity arriving at a node was combined together using summation (as is the case here) or using a MAX operator (Riesenhuber and Poggio, 1999). The result is that the network can not

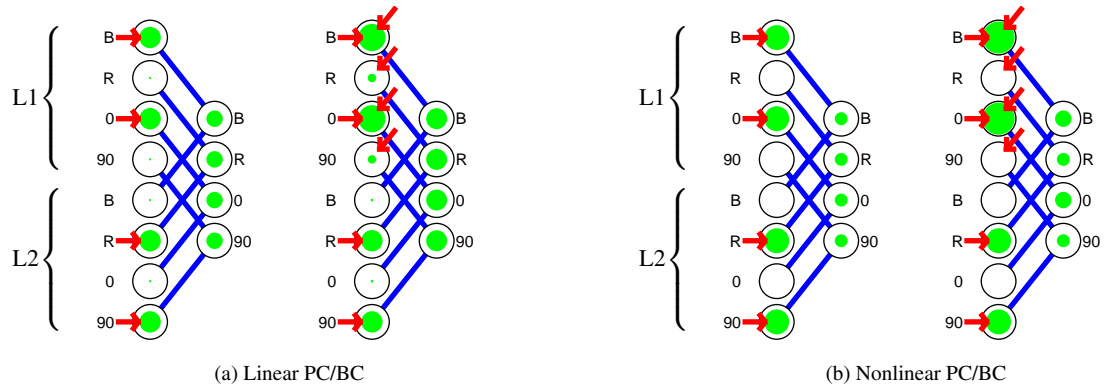

Figure 11: The effects of selective spatial attention on feature binding in a simple task simulated with (a) the linear PC/BC model, and (b) the nonlinear PC/BC model. Each subplot shows the responses of the prediction nodes in the first and second processing stages to different combinations of input stimuli and attentional states. The strength of each node’s response (at the end of 20 iterations) is indicated by the diameter of the shading. Two sets of four prediction nodes in the first processing stage represent the same features at different spatial locations (‘L1’ and ‘L2’). The four prediction nodes in the second processing stage represent *disjunctions*, so as to be active in response to a specific feature irrespective of its location. The format of the diagram is otherwise identical to, and described in the caption of, Figure 10.

determine which colour goes with which orientation. Stimuli that contained features ‘R’ and ‘90’ at location ‘L1’ and ‘B’ and ‘0’ at location ‘L2’ would produce the same response in the second processing stage, as would other combinations of input features. The solution (as proposed by Treisman, 1998; Treisman and Gelade, 1980) is to employ spatial attention in order to enhance the responses produced by features at the attended location.

The effects of spatial attention directed to one location (and hence enhancing the responses to all first stage nodes responsive to features at that location) is shown in the second column of Figures 11a for the linear PC/BC model and the second column of Figure 11b for the nonlinear PC/BC model. For the linear model spatial attention fails to resolve the binding problem in this example, as all the nodes in the second processing stage generate an equal response. This is due to each feature within the attended location receiving equal additive top-down excitation. This in turn results in each node in the second stage receiving equal feedforward excitation. In contrast for the nonlinear model, spatial attention does succeed in labelling the features to be bound with an enhanced activity. Specifically, for this example, the second processing stage nodes representing features ‘B’ and ‘0’ have a 30% higher activation than the ‘R’ and ‘90’ nodes. This results from attention having a modulatory, rather than an additive, effect in the nonlinear model. Only those nodes in the first processing stage that receive bottom-up stimulation have their activity enhanced by attention, and hence can send enhanced activity to the corresponding nodes in the second stage.

Note that, in a larger hierarchical model, the output of the network shown in Figure 11 could provide the input to the second processing stage of the network shown in Figure 10. Spatial attention to a set of features at one location, leading to enhanced activity in the disjunctive nodes coding for an object at that location (as produced in the nonlinear model in Figure 11b) would lead to the correct binding of features in a subsequent conjunction node since it was found in the previous section that an imbalance in contrast was sufficient to cause one conjunction node to be more active than any other (see Figure 10 column 3). This would provide a mathematically explicit implementation of the model described in Roelfsema et al. (2000, Fig. 9).

4 Discussion

The results show that the linear PC/BC model is able simulate a number of attention experiments. The linear PC/BC model is mathematically identical to the linear predictive coding model proposed by Rao and Ballard (1999). The only differences are a simple rearrangement of the equations, and a different interpretation in terms of the proposed neural implementation. Hence, this result is surprising given the very different and incompatible predictions that have previously been claimed for PC and BC. However, the proposed reinterpretation of the PC model can be construed as a form of BC model in which the competition is performed via negative feedback (Harpur and Prager, 1996, 1994). Hence, from this new perspective, the linear model would be expected to simulate attention data that has previously been interpreted in terms of biased competition.

The linear PC/BC model produces a good fit to the empirical data for the experiments on spatial and featural selectivity (Sections 3.1.1, 3.1.2, and 3.1.3), and for featural facilitation of the tuning response function (Section 3.2.2). One issue in each of these cases is the generation of negative activation values. The negative responses could be removed by clipping the prediction node activations at zero (*i.e.*, by modifying equation 8 to take the positive half-rectified value of the right-hand-side). This has little influence on the positive part of the prediction response curves and hence provides a closer fit to the experimental data.

An alternative method of avoiding the issue of negative activation values was used in the nonlinear PC/BC model. The nonlinear model divisively modulates the prediction node inputs, whereas the linear model subtractively inhibits the prediction node inputs. Hence, the nonlinear model employs a different mechanism for producing competition between the prediction nodes in each processing stage. One advantage of this nonlinear mechanism of competition is that the responses of both the prediction nodes and the error-detecting nodes are inherently bound to be non-negative. Another advantage of the nonlinear mechanism, over the linear mechanism, of competition is that it produces more accurate parsings of images into their elementary components (Spratling et al., 2009). Figure 10 shows some simple examples of improved parsings: in the first column the nonlinear competition results in a probabilistically correct activity level in each of the two possible parsings of the ambiguous input, and in columns four and six the activity of nodes representing patterns not present in the input is suppressed more successfully by the nonlinear mechanism of competition.

While the linear PC/BC model successfully simulates a number of single-cell electrophysiology experiments (as listed above) it fails to model the data for spatial facilitation of the tuning response function (Section 3.2.1). It also fails to model behavioural data measuring the effects of spatial attention on reaction times (Section 3.3) or to provide a theoretical account of feature binding (Sections 3.4.1 and 3.4.2). The issue here is that, in the linear model, the top-down activation received by the prediction nodes is additive. This means that top-down predictions can cause node activations in the absence of any bottom-up stimulation. The nonlinear PC/BC model avoids this problem by employing a form of cortical feedback that is multiplicatively modulatory.

The nonlinear PC/BC model proposed in this article includes two nonlinear modifications to the linear PC/BC model: a divisive form of intracortical competition, and a multiplicative form of intercortical feedback. This nonlinear model has been shown to provide a good qualitative fit to the empirical data for experiments on spatial and featural selectivity (Sections 3.1.1, 3.1.2, and 3.1.3), and experiments on the effects of spatial and featural facilitation on tuning response functions (Sections 3.2.1 and 3.2.2). It also successfully simulates the Posner task (Section 3.3) and provides a theoretical account of the role of spatial and featural attention in solving the binding problem (Sections 3.4.1 and 3.4.2).

4.1 Relationship to Other Models

The models presented in this article are clearly very closely related to both predictive coding models and biased competition models. There is also strong similarity to a variety of other models, as discussed below. The range of empirical data that has been simulated with the nonlinear PC/BC model in this article may, or may not, present a challenge for these other models of attention. However, the main contribution of this paper is not a model that can uniquely account for certain data, but a model that reconciles two theories which were previously considered incompatible. Since the attention literature seemed to be most at odds with the predictive coding hypothesis, this data was chosen to demonstrate that such a reconciliation was possible.

The predictive coding hypothesis was originally formulated to describe the information processing performed in the retina (Srinivasan et al., 1982). Retinal circuitry is believed to predict the local intensity values expected at a particular spatial location and to subtract this prediction (via lateral inhibition) from the actual intensity. The prediction is generated from intensity values measured at nearby locations and from those measured at preceding times, hence predictive coding is performed in both the temporal and spatial domains (Laughlin, 1990; Srinivasan et al., 1982). Recent evidence suggests that lateral connection strengths in the retina are modified by experience so as to dynamically adjust the predictions generated to the statistics of the current visual environment (Hosoya et al., 2005). The signal generated following subtraction of the predicted information has a smaller dynamic range than the raw intensity values and hence can be transmitted with greater accuracy using a limited range of firing rates. By removing predictable information for the transmitted data the retina can be considered to perform redundancy reduction as proposed by Barlow (2001, 1960).

The predictive coding hypothesis was subsequently applied to explain cortical information processing (*e.g.*, Barlow, 1994; Friston, 2005; Jehee et al., 2006; Kilner et al., 2007; Mumford, 1992; Murray et al., 2004; Rao and Ballard, 1999; Rao and Sejnowski, 2002). However, only one previous implementation of predictive coding has been applied to modelling attention. Rao and Ballard (2004) used a variation of the predictive coding model described in Rao and Ballard (1999) to show that top-down knowledge of spatial location would result in preferential processing of featural information associated with an object at that location. Similarly, bias towards a particular

object representation would result in the selection of the location occupied by that object. These results appear consistent with biased competition, although this link is not made in [Rao and Ballard \(2004\)](#). These results also seem to be superficially consistent with behaviour, but no actual psychophysical or neurophysiological data was simulated.

This article has shown that predictive coding can be construed as a form of biased competition model. Hence, one interpretation of the PC/BC model is that neurons (prediction nodes) compete to be active and the outcome of this competition is influenced not only by bottom-up, sensory-driven, processes but also by top-down, attention-dependent, biases. Many other neural network models of attention are based on the same principles of biased competition (*e.g.*, [Corchs and Deco, 2002](#); [Deco et al., 2002](#); [Hamker, 1999, 2002](#); [Phaf et al., 1990](#); [Rolls and Deco, 2002](#); [Usher and Niebur, 1996](#)). The principal difference between the PC/BC model and previous biased competition models is the mechanism used to perform the competition. In previous models, neurons within a cortical region compete to generate outputs. In the PC/BC model, neurons compete to receive inputs. The former mechanism can be implemented using a form of lateral inhibition that targets node outputs whereas the latter mechanism is implemented using inhibition that targets the inputs to a population of competing nodes. Competition for inputs was the main mechanism through which both the linear and nonlinear PC/BC models succeeded in simulating the suppressive effects of a poor stimulus when the selectivity of the recorded node varied (Section 3.1.2). It would therefore be interesting to know if other biased competition models, employing the standard mechanisms of competition, could also simulate this data.

A second difference between previous implementations of biased competition and the nonlinear PC/BC model is the mechanism used to provide the top-down bias. In most previous models (and in the linear PC/BC model), cortical feedback connections are considered to have an additive effect, whereas in the nonlinear PC/BC model cortical feedback has a multiplicative effect. The multiplicative response modulation employed in the nonlinear PC/BC model enabled it to simulate a much wider range of data than the linear PC/BC model (see discussion above). Hence, it seems likely that the nonlinear PC/BC model will have a similar advantage over other biased competition models that employ additive feedback.

An influential class of models of visual attention are based on the concept of a saliency map (*e.g.*, [Heinke and Humphreys, 2003](#); [Heinke et al., 2002](#); [Itti and Koch, 2001](#); [Koch and Ullman, 1985](#); [Mozer, 1988](#); [Navalpakkam and Itti, 2006](#); [Wolfe, 1994](#)). In such models, saliency values for each spatial location are calculated. The calculation of saliency may be purely stimulus-driven or may also be affected by top-down biases. Competition occurs such that the location with the highest salience is chosen as the focus of attention. Hence, in common with biased competition models (including the PC/BC model), saliency map models also perform competition and the outcome of this competition may be influenced by both bottom-up and top-down factors. However, saliency map models differ from biased competition models (including the PC/BC model) in three significant ways. Firstly, rather than postulating a single map where ultimately the competition is resolved, biased competition models propose that competition is performed across a distributed network of interacting cortical regions. Secondly, saliency map models split perceptual processing into two temporally separate stages: the saliency map is used to select the focus of attention and information at this selected location is subsequently sent for further processing (*e.g.*, object recognition). In contrast, the neural activity that is generated following competition in the biased competition model is itself a representation of the stimulus. The biased competition model thus resolves the dichotomy between early ([Broadbent, 1958](#); [Treisman, 1969](#)) and late ([Deutsch and Deutsch, 1963](#); [Shiffrin and Schneider, 1977](#)) selection theories of attention by challenging the traditional view (which is implicit to saliency map models) that there are distinct pre-attentive and attentive stages in perceptual processing ([Broadbent, 1958](#)). The third distinction between saliency map models and biased competition models is that the former employs distinct mechanisms (*i.e.*, separate pathways) for dealing with saliency and featural information (*i.e.*, these two forms of information are not only dealt with at different times, but also using different neural hardware). In contrast, in the biased competition model, saliency is related to activation strength while featural (and spatial) information is related to the identity of the neuron (*i.e.*, place coding) so both types of information can be manipulated independently within a single neural system.

In the nonlinear PC/BC model, when the strength of the top-down, attentional, signal varies across a population of neurons, this can lead to both response enhancement and suppression in different subsets of prediction nodes (*e.g.*, Section 3.2.2). Enhanced activity is a direct effect of attention: resulting from the response gain in nodes that receive strong top-down input. Suppressed activity is an indirect effect of attention mediated by the competition between the prediction nodes: increased activity in some nodes results in stronger inhibition and hence more suppression in other nodes. In contrast, the “feature similarity gain model” ([Martinez-Trujillo and Treue, 2004](#); [Treue and Martinez-Trujillo, 1999](#)) proposes that both enhanced and reduced responses are a direct effect of attention which can change the response gain of a cell (both up and down) in proportion to the similarity between the attended stimulus and the preferred stimulus of the neuron. The proposed model, in common with that of [Ardid et al. \(2007\)](#), generates the same effect via biased competition. An alternative model ([Boynton, 2005](#)) employs

both competition between nodes and direct suppressive and excitatory effects of attention.

When attention results in the response modulation of a subset of the inputs to a recorded neuron, both the linear and nonlinear PC/BC models generate responses that are more similar to those that would have been produced if the attended inputs had been presented in isolation (*e.g.*, Section 3.1.1). These effects when observed in electrophysiological data have been described in terms of a shrinkage of the RF around the attended stimulus (Connor et al., 1997; Moran and Desimone, 1985). However, rather than any change in the RF properties of the recorded neuron, the model proposes, as have others before (Connor et al., 1997; Maunsell and McAdams, 2000; McAdams and Maunsell, 1999; Womelsdorf et al., 2006), that the apparent RF distortion arises from a change in the pattern of feedforward stimulation received by the cell, coupled with the effect modulating the afferent input has on the competition occurring between cells.

The selective enhancement of certain neural responses over others is central to several other models. These models differ from nonlinear PC/BC in not specifying a mechanism, or proposing a different mechanism, to bring about selective response enhancement. Also, the role of response enhancement has been described in different ways: as a mechanism for preferentially routing information through the cortical hierarchy (Olshausen et al., 1993; Tsotsos et al., 1995), as a means of performing coordinate transforms (Salinas and Abbott, 1997; Salinas and Thier, 2000), as a method of binding and image segmentation (Roelfsema, 2006; Roelfsema et al., 2000), or as a mechanism for probabilistically combining prior knowledge with current evidence (Friston, 2005; Lee and Mumford, 2003; Rao, 2005). The behaviour of the nonlinear PC/BC model might be described in the same terms. There are, therefore, other alternative perspectives on the PC/BC model in addition to the perspectives of predictive coding and biased competition which have been the focus of this article.

4.2 Predictions

All prior proposals for how predictive coding could be implemented in cortical circuitry have suggested that cortical feedforward connections transmit residual errors and cortical feedback pathways transmit predictions (Barlow, 1994; Friston, 2005; Jehee et al., 2006; Kilner et al., 2007; Mumford, 1992; Murray et al., 2004; Rao and Ballard, 1999; Rao and Sejnowski, 2002, See Figure 1a). This proposed mapping of the model onto neural hardware requires that the effects of cortical feedback be subtractive in order that the residual error can be calculated from the top-down prediction. It is this requirement that places the model at apparent odds with single-cell neurophysiological data showing that the effects of cortical feedback are predominately excitatory (Johnson and Burkhalter, 1997; Shao and Burkhalter, 1996) and that top-down predictions, such as those generated during attention, act to enhance, rather than suppress, predicted neural activity (Hupé et al., 1998; Kastner and Ungerleider, 2000; Luck et al., 1997a; Olson, 2001; Schroeder et al., 2001).

The PC/BC model proposes an alternative implementation of predictive coding (as shown in Figure 1b), in which both cortical feedforward and feedback connections have excitatory effects, and the calculation of the residual error is performed via lateral inhibitory connections intrinsic to each cortical region. This proposed implementation is thus closer to the original formulation of predictive coding which proposed that lateral inhibitory connections in the retina were used to calculate residual errors (Srinivasan et al., 1982). The PC/BC model thus makes distinct predictions, from other cortical predictive coding models, about the role of cortical feedback connections: feedback should be excitatory. This prediction is consistent with the role of cortical feedback proposed in the biased competition model.

The nonlinear (but not the linear) PC/BC model is distinct for most implementations of biased competition in proposing that cortical feedback, including that resulting from attention, causes a multiplicative modulation of the responses of neurons receiving top-down input. Several physiological mechanisms have been identified that could allow cortical feedback to have a direct modulatory effect on neural responses (Friston, 2005; Larkum et al., 2004; Spruston, 2008; Sripathi and Johnson, 2006). This top-down modulation results in a response gain when attention acts directly on the recorded neuron, or when attention equally modulates all the inputs to that neuron. This is consistent with a number of empirical findings (McAdams and Maunsell, 1999; Treue and Martinez-Trujillo, 1999). Increasing the response gain of neurons in one processing stage effectively increases the contrast gain for neurons in subsequent stages which receive input from the modulated neurons. This is consistent with the findings of Reynolds et al. (2000). Hence, rather than seeing response gain and contrast gain as incompatible, rival, mechanisms (Reynolds and Desimone, 2003; Williford and Maunsell, 2006) the nonlinear PC/BC model proposes that both types of effect arise from the same underlying mechanism, and should both be observed in the cortex. Indeed, since cortical feedback signals are likely to simultaneously activate multiple levels in the cortical hierarchy, and may arise simultaneously from multiple sources, it is likely that many experiments will observe a combination of both response gain and contrast gain.

Rao and Ballard (1999) proposed that predictions, generated by the selectivities of neurons in higher cortical regions, would influence the tuning properties of cells in lower cortical regions (*e.g.*, causing end-stopping). The

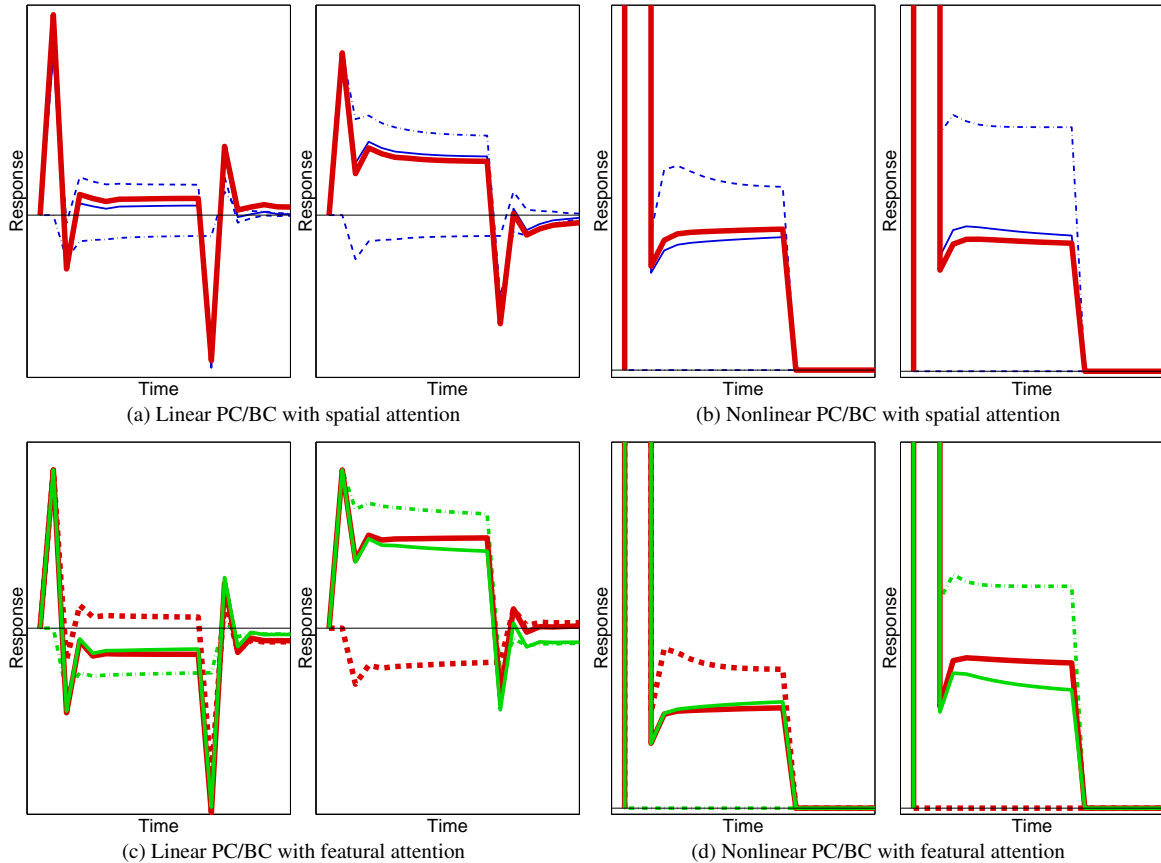

Figure 12: The effect of attention on the response of error-detecting nodes in (a) and (c) the linear PC/BC model, and (b) and (d) the nonlinear PC/BC model. The responses shown are from each of the two error-detecting nodes that supply feedforward activation to the prediction node whose response was recorded, with changing spatial attention, in Figure 3 (top row of this figure) and, for changing featural attention, in Figure 6 (bottom row of this figure). The value of zero on the y-axis is indicated by the thin horizontal lines in both plots. The different line styles in each plot correspond to the same experimental conditions plotted in Figures 3 and 6, however, note that the “poor” and “pref” stimuli refer to the selectivity of the prediction node recorded in Figures 3 and 6, and not necessarily the tuning properties of the error-detecting nodes recorded in this figure.

PC/BC model proposes the same. However, this article has explored the influence of another source of top-down prediction: attention. Attention can be seen as another form of prediction that can influence tuning properties, as is seen empirically the single-cell responses that were modelled in this article. The PC/BC model therefore predicts that similar effects on neural response properties should be observed in different circumstances where top-down predictions/biases come from past learning (long-term memory for familiar stimuli), past exposure (short-term memory resulting in priming) or expectation (attention).

While the PC/BC model does not propose that cortical feedback acts directly to inhibit predicted responses, it does still propose that such suppression occurs (via lateral inhibition) and hence that there should be a population of error-detecting nodes within each cortical region. The behaviour of these error-detecting nodes has previously been considered to be inconsistent with single-cell physiology (Hamker, 2006; Koch and Poggio, 1999). However, the presumption made by these objections to predictive coding is that the top-down prediction is generally accurate and hence that the response of the error-detecting nodes should generally be entirely suppressed. In reality, completely accurate top-down predictions may be rare and hence it may be more difficult to identify a separate error-detecting node population. To illustrate this issue, Figure 12 shows the behaviour of both error-detecting nodes (in the second processing stage) during the simulation of the effects of spatial attention reported in Section 3.1.1 (top row of Figure 12) and during the simulation of the effects of featural attention reported in Section 3.1.3 (bottom row of Figure 12).

Initially the response of the error-detecting nodes is large due to there being no top-down prediction when the stimulus first appears. In the nonlinear model this error value is approximately equal to $\frac{1}{\epsilon}$ and is thus very large

given the value of this parameter used in these simulations. However, a smaller peak error can be obtained by using a larger value of ϵ and similar behaviour of the prediction node (to that shown in Figure 3c and 6c) can be obtained by adjusting other parameters. At later times, as the prediction nodes provide a better prediction of their inputs, the response of the error-detecting node becomes smaller. If the prediction node responses perfectly predicted the input then in the linear model the response of the error-detecting node would tend towards zero, whereas in the nonlinear model the response of the error-detecting node would become equal to one (except when the bottom-up input was zero in which case the response of the error-detecting node would also be zero). The selectivities of the prediction nodes in the simulated networks do not enable the stimuli to be represented without error, hence this ideal situation is never realised. Rather each error-detecting node shows highest response to one of the two stimuli presented in isolation and lowest response to the other stimulus in isolation. The highest sustained response from each error-detecting node is similar in magnitude to the response of the prediction nodes (recorded in Figures 3 and 6) to their preferred stimuli. As with the prediction nodes, when the pair of stimuli are presented the responses of the error-detecting nodes are intermediate between the responses generated by the stimuli in isolation. In contrast to the prediction node responses, the error-detecting node responses are not strongly affected by attention. It is clear from comparing the top row of Figure 12 with Figure 3 and the bottom row of Figure 12 with Figure 6, that the error-detecting node responses have very similar characteristics to the prediction node responses. It is therefore conceivable that these separate populations of cortical neurons have been recorded in single-cell physiology experiments, but that they have not been identified as distinct.

If populations of error-detecting and prediction nodes do exist in cortex, then the model would predict that the main distinguishing characteristic of the error-detecting nodes is their lack of attentional modulation. Another difference could be measured by recording cells during a perceptual learning experiment. The response of a prediction node selective to a particular stimulus should become stronger as it is trained to become even more selective to that stimulus. In contrast, error-detecting node responses should decrease during such training as the prediction nodes learn to generate better predictions. It is also possible that predictive coding could be implemented in cortex without the need for a separate population of error-detecting nodes. Instead the selective suppression of specific inputs to prediction nodes could be achieved via inhibitory contacts targeting the dendrites of prediction nodes (Spratling and Johnson, 2001, 2002, 2003). The question of whether error-detection nodes exist or if their functionality is achieved via dendritic computation is a matter for empirical research. In either case, the removal of the effects of lateral inhibition should cause prediction nodes to show increased response to specific stimulus features rather than simply causing a general dis-inhibition to all stimuli. Such effects have been recorded in cortical area TE (Wang et al., 2000). Another prediction arising from this form of inhibition is illustrated in the second column of Figure 10. If attention leads to the binding of certain image features, it should also result in the binding together of unattended image features. The standard mechanism of competition, as employed in most other models of biased competition, would predict that all possible bindings, except the attended one, would remain equally active.

4.3 Future Work

No attempt has been made in the PC/BC model to simulate the response time course of cortical cells. Hence, it is not at all surprising that there are discrepancies between the simulated and empirical data shown in Figures 3, 4, and 6. In all these simulations the initial, transient, response generated by the model is significantly different from that generated in the cortical cells, while the response of the model following the initial transient more accurately models the empirical data. Specifically, in all three experiments the response to the pair of stimuli initially exceeds the response generated by the preferred stimulus presented in isolation. Furthermore, in Figure 4 the transient response to the pair of stimuli increases as the contrast of the poor stimulus increases. In contrast, the physiological data shows increasing the contrast of the poor stimulus, suppresses the response over the entire time period. Another discrepancy between the temporal response profiles measured from the model and the response histograms of the empirical data are the more rapid decay in the response to the poor stimulus in the model compared to the data.

Hence, one aim of future research might be to improve the temporal response characteristics of the model. One simple method of doing this might be to smooth the simulated response profile by taking the average response within a finite time window. Such temporal averaging is used to generate response histograms from the raw spike counts in the physiological experiments. Another issue is that of propagation delays along axons. Currently in the model there are no time delays, but these are likely to have a significant effect on the temporal response profile. Finally, in the retina predictive coding is believed to operate in both the spatial and temporal domains (Srinivasan et al., 1982). The current PC/BC model does not consider predictive coding in the temporal domain. However, incorporating such temporal predictions would be likely to have a significant effect on the temporal response characteristics of the model. Such temporal predictions could be incorporated into the model by allowing

prediction nodes to be self-excitatory. Hence, past activity of the prediction nodes would provide predictions about future inputs.

5 Conclusions

Predictive coding hypothesises that cortical feedback connections act to suppress information predicted by higher-level cortical regions, so that only the residual error between the top-down prediction and the bottom-up input is propagated from one cortical region to the next along a processing pathway. In contrast, biased competition proposes that cortical feedback acts to enhance stimulus-driven neural activity that is consistent with top-down predictions and that this enhancement of activity can in turn affect the outcome of competition occurring within each cortical region. In terms of the role of cortical feedback connections, these two models thus appear to be diametrically opposed. However, it is shown in this article that the mathematical model underlying predictive coding can be reinterpreted as a form of biased competition model. To demonstrate that this reinterpreted model can perform biased competition, it has been used to successfully simulate a number of single-cell electrophysiological experiments in the attention domain, which have previously been explained in terms of the biased competition model. Furthermore, nonlinear modifications to the reformulated predictive coding model have been proposed that improve its performance in simulating the empirical data and in addition improve the stability of the algorithm. The proposed nonlinear algorithm also enables the reinterpreted predictive coding model of biased competition to provide a theoretical explanation for the role of attention in solving the binding problem.

Acknowledgements

Thanks to Kris De Meyer and two anonymous referees for helpful comments on earlier drafts of this article. This work was funded by EPSRC Research Grants GR/S81339/01 and EP/D062225/1.

References

- Andersen, R. A., Essick, G. K., and Siegel, R. M. (1985). Encoding of spatial location by posterior parietal neurons. *Science*, 230(4724):456–8.
- Ardid, S., Wang, X.-J., and Compte, A. (2007). An integrated microcircuit model of attentional processing in the neocortex. *The Journal of Neuroscience*, 27(32):8486–95.
- Barlow, H. (2001). Redundancy reduction revisited. *Network: Computation in Neural Systems*, 12:241–53.
- Barlow, H. B. (1960). The coding of sensory messages. In Thorpe, W. H. and Zangwill, O. L., editors, *Current Problems in Animal Behaviour*, pages 331–60. Cambridge University Press, Cambridge, UK.
- Barlow, H. B. (1994). What is the computational goal of the neocortex? In Koch, C. and Davis, J. L., editors, *Large-Scale Neuronal Theories of the Brain*, chapter 1. MIT Press, Cambridge, MA.
- Boynton, G. M. (2005). Attention and visual perception. *Current Opinion in Neurobiology*, 15(4):465–9.
- Broadbent, D. E. (1958). *Perception and communication*. Pergamon, London, UK.
- Brotchie, P. R., Andersen, R. A., Snyder, L. H., and Goodman, S. J. (1995). Head position signals used by parietal neurons to encode locations of visual stimuli. *Nature*, 375(6528):232–5.
- Chelazzi, L., Miller, E. K., Duncan, J., and Desimone, R. (2001). Responses of neurons in macaque area V4 during memory-guided visual search. *Cerebral Cortex*, 11(8):761–72.
- Connor, C. E., Preddie, D. C., Gallant, J. L., and Van Essen, D. C. (1997). Spatial attention effects in macaque area V4. *Journal of Neuroscience*, 17(9):3201–14.
- Corchs, S. and Deco, G. (2002). Large-scale neural model for visual attention: integration of experimental single cell and fMRI data. *Cerebral Cortex*, 12(4):339–48.
- Crick, F. and Koch, C. (1998). Constraints on cortical and thalamic projections: the no-strong-loops hypothesis. *Nature*, 391:245–50.
- De Weerd, P., Peraltá, M. R., Desimone, R., and Ungerleider, L. G. (1999). Loss of attentional stimulus selection after extrastriate cortical lesions in macaques. *Nature Neuroscience*, 2(8):753–8.
- Deco, G., Pollatos, O., and Zihl, J. (2002). The time course of selective visual attention: theory and experiments. *Vision Research*, 42(27):2925–45.
- Deco, G. and Rolls, E. T. (2005). Neurodynamics of biased-competition and cooperation for attention: A model with spiking neurons. *Journal of Neurophysiology*, 94:295–313.
- Deutsch, J. A. and Deutsch, D. (1963). Attention: some theoretical considerations. *Psychological Review*, 70:80–90.

- Everling, S., Tinsley, C. J., Gaffan, D., and Duncan, J. (2002). Filtering of neural signals by focused attention in the monkey prefrontal cortex. *Nature Neuroscience*, 5(7):671–6.
- Friston, K. J. (2005). A theory of cortical responses. *Philosophical Transactions of the Royal Society B: Biological Sciences*, 360(1456):815–36.
- Grossberg, S. and Raizada, R. (2000). Contrast-sensitive perceptual grouping and object-based attention in the laminar circuits of primary visual cortex. *Vision Research*, 40(10-12):1413–32.
- Hamker, F. H. (1999). The role of feedback connections in task-driven visual search. In Heinke, D., Humphreys, G. W., and Olson, A., editors, *Connectionist Models in Cognitive Neuroscience: Proceedings of the 5th Neural Computation and Psychology Workshop (NCPW98)*, pages 252–61, London, UK. Springer-Verlag.
- Hamker, F. H. (2002). How does the ventral pathway contribute to spatial attention and the planning of eye movements? In Würtz, R. P. and Lappe, M., editors, *Proceedings of the 4th Workshop on Dynamic Perception*, pages 83–8, St. Augustin, Germany. Infix Verlag.
- Hamker, F. H. (2006). Modeling feature-based attention as an active top-down inference process. *BioSystems*, 86:91–9.
- Harpur, G. and Prager, R. (1996). Development of low entropy coding in a recurrent network. *Network: Computation in Neural Systems*, 7(2):277–84.
- Harpur, G. F. and Prager, R. W. (1994). A fast method for activating competitive self-organising neural networks. In *Proceedings of the International Symposium on Artificial Neural Networks*, pages 412–8.
- Heinke, D. and Humphreys, G. W. (2003). Attention, spatial representation and visual neglect: simulating emergent attention and spatial memory in the selective attention for identification model (SAIM). *Psychological Review*, 110(1):29–87.
- Heinke, D., Humphreys, G. W., and di Virgilio, G. (2002). Modeling visual search experiments: selective attention for identification model (SAIM). *Neurocomputing*, 44-46:817–22.
- Hosoya, T., Baccus, S. A., and Meister, M. (2005). Dynamic predictive coding by the retina. *Nature*, 436(7047):71–7.
- Hupé, J. M., James, A. C., Payne, B. R., Lomber, S. G., Girard, P., and Bullier, J. (1998). Cortical feedback improves discrimination between figure and background by V1, V2 and V3 neurons. *Nature*, 394(6695):784–7.
- Itti, L. and Koch, C. (2001). Computational modelling of visual attention. *Nature Reviews Neuroscience*, 2(3):194–202.
- Jehee, J. F. M., Rothkopf, C., Beck, J. M., and Ballard, D. H. (2006). Learning receptive fields using predictive feedback. *Journal of Physiology – Paris*, 100:125–32.
- Johnson, R. R. and Burkhalter, A. (1997). A polysynaptic feedback circuit in rat visual cortex. *Journal of Neuroscience*, 17(18):7129–40.
- Kastner, S. and Ungerleider, L. G. (2000). Mechanisms of visual attention in the human cortex. *Annual Review of Neuroscience*, 23:315–41.
- Kilner, J. M., Friston, K. J., and Frith, C. D. (2007). Predictive coding: an account of the mirror neuron system. *Cognitive Processing*, 8(3):159–66.
- Koch, C. and Poggio, T. (1999). Predicting the visual world: silence is golden. *Nature Neuroscience*, 2(1):9–10.
- Koch, C. and Ullman, S. (1985). Shifts in selective visual attention: towards the underlying neural circuitry. *Human Neurobiology*, 4(4):219–27.
- Larkum, M. E., Senn, W., and Lüscher, H.-R. (2004). Top-down dendritic input increases the gain of layer 5 pyramidal neurons. *Cerebral Cortex*, 14(10):1059–70.
- Laughlin, S. (1990). Coding efficiency and visual processing. In Blakemore, C., editor, *Vision: Coding and Efficiency*, chapter 2, pages 25–31. Cambridge University Press.
- Lee, D. D. and Seung, H. S. (1999). Learning the parts of objects by non-negative matrix factorization. *Nature*, 401:788–91.
- Lee, T. S. and Mumford, D. (2003). Hierarchical Bayesian inference in the visual cortex. *Journal of the Optical Society of America A: Optics, Image Science, and Vision*, 20:1434–48.
- Luck, S. J., Chelazzi, L., Hillyard, S. A., and Desimone, R. (1997a). Neural mechanisms of spatial selective attention in areas V1, V2, and V4 of macaque visual cortex. *Journal of Neurophysiology*, 77:24–42.
- Luck, S. J. and Ford, M. A. (1998). On the role of selective attention in visual perception. *Proc. National Academy of Sciences USA*, 95:825–30.
- Luck, S. J., Girelli, M., McDermott, M. T., and Ford, M. A. (1997b). Bridging the gap between monkey neurophysiology and human perception: An ambiguity resolution theory of visual selective attention. *Cognitive Psychology*, 33:64–87.
- Martinez-Trujillo, J. C. and Treue, S. (2002). Attentional modulation strength in cortical area MT depends on stimulus contrast. *Neuron*, 35(2):365–70.
- Martinez-Trujillo, J. C. and Treue, S. (2004). Feature-based attention increases the selectivity of population

- responses in primate visual cortex. *Current Biology*, 14:744–51.
- Maunsell, J. H. R. and McAdams, C. J. (2000). Effects of attention on neural response properties in visual cerebral cortex. In Gazzaniga, M. S., editor, *The New Cognitive Neurosciences*, pages 315–24. MIT Press, Cambridge, MA.
- McAdams, C. J. and Maunsell, J. H. R. (1999). Effects of attention on orientation-tuning functions of single neurons in macaque cortical area V4. *Journal of Neuroscience*, 19(1):431–41.
- Moran, J. and Desimone, R. (1985). Selective attention gates visual processing in the extrastriate cortex. *Science*, 229(4715):782–4.
- Motter, B. C. (1993). Focal attention produces spatially selective processing in visual cortical areas V1, V2, and V4 in the presence of competing stimuli. *Journal of Neurophysiology*, 70(3):909–19.
- Mozer, M. C. (1988). A connectionist model of selective attention in visual perception. In *Proceedings of the 10th Annual Conference of the Cognitive Science Society*, pages 195–201, Hillsdale, NJ. Erlbaum.
- Mumford, D. (1992). On the computational architecture of the neocortex II: the role of cortico-cortical loops. *Biological Cybernetics*, 66:241–51.
- Murray, S. O., Schrater, P., and Kersten, D. (2004). Perceptual grouping and the interactions between visual cortical areas. *Neural Networks*, 17:695–705.
- Navalpakkam, V. and Itti, L. (2006). An integrated model of top-down and bottom-up attention for optimizing detection speed. In *Proceedings of the IEEE Conference on Computer Vision and Pattern Recognition (CVPR)*, pages 2049–56.
- Olshausen, B. A., Anderson, C. H., and Van Essen, D. C. (1993). A neurobiological model of visual attention and invariant pattern recognition based on dynamic routing of information. *The Journal of Neuroscience*, 13(11):4700–19.
- Olson, C. R. (2001). Object-based vision and attention in primates. *Current Opinion in Neurobiology*, 11(2):171–9.
- Phaf, R. H., Van der Heijden, A. H. C., and Hudson, P. T. W. (1990). SLAM: a connectionist model for attention in visual selection tasks. *Cognitive Psychology*, 22(3):273–341.
- Posner, M. I. (1980). Orienting of attention. *Quarterly Journal of Experimental Psychology*, 32(1):3–25.
- Rao, R. P. N. (2005). Hierarchical Bayesian inference in networks of spiking neurons. In Saul, L. K., Weiss, Y., and Bottou, L., editors, *Advances in Neural Information Processing Systems 17*, pages 1113–1120, Cambridge, MA. MIT Press.
- Rao, R. P. N. and Ballard, D. H. (1999). Predictive coding in the visual cortex: a functional interpretation of some extra-classical receptive-field effects. *Nature Neuroscience*, 2(1):79–87.
- Rao, R. P. N. and Ballard, D. H. (2004). Probabilistic models of attention based on iconic representations and predictive coding. In Itti, L., Rees, G., and Tsotsos, J. K., editors, *Neurobiology of Attention*, pages 553–61. Elsevier.
- Rao, R. P. N. and Sejnowski, T. J. (2002). Predictive coding, cortical feedback, and spike-timing dependent plasticity. In Rao, R. P. N., Olshausen, B. A., and Lewicki, M. S., editors, *Probabilistic models of the brain: Perception and neural function*, pages 297–315. MIT Press, Cambridge, MA.
- Reynolds, J. H. and Chelazzi, L. (2004). Attentional modulation of visual processing. *Annual Review of Neuroscience*, 27:611–47.
- Reynolds, J. H., Chelazzi, L., and Desimone, R. (1999). Competitive mechanisms subserve attention in macaque areas V2 and V4. *Journal of Neuroscience*, 19:1736–53.
- Reynolds, J. H. and Desimone, R. (1999). The role of neural mechanisms of attention in solving the binding problem. *Neuron*, 24(1):19–29.
- Reynolds, J. H. and Desimone, R. (2003). Interacting roles of attention and visual salience in V4. *Neuron*, 37:853–63.
- Reynolds, J. H., Pasternak, T., and Desimone, R. (2000). Attention increases sensitivity of V4 neurons. *Neuron*, 26:703–14.
- Riesenhuber, M. and Poggio, T. (1999). Are cortical models really bound by the “binding problem”? *Neuron*, 24(1):87–93.
- Roelfsema, P. R. (2006). Cortical algorithms for perceptual grouping. *Annual Review of Neuroscience*, 29:203–27.
- Roelfsema, P. R., Lamme, V. A. F., and Spekreijse, H. (2000). The implementation of visual routines. *Vision Research*, 40:1385–411.
- Rolls, E. T. and Deco, G. (2002). *Computational Neuroscience of Vision*. Oxford University Press, Oxford, UK.
- Rosenblatt, F. (1961). *Principles of Neurodynamics: Perceptrons and the Theory of Brain Mechanisms*. Spartan Books, Washington; DC.
- Salinas, E. and Abbott, L. F. (1997). Invariant visual perception from attentional gain fields. *Journal of Neurophysiology*, 77(6):3267–72.

- Salinas, E. and Thier, P. (2000). Gain modulation: a major computational principle of the central nervous system. *Neuron*, 27:15–21.
- Schroeder, C. E., Mehta, A. D., and Foxe, J. J. (2001). Determinants and mechanisms of attentional modulation of neural processing. *Frontiers in Bioscience*, 6:d672–84.
- Shao, Z. and Burkhalter, A. (1996). Different balance of excitation and inhibition in forward and feedback circuits of rat visual cortex. *Journal of Neuroscience*, 16(22):7353–65.
- Shiffrin, R. M. and Schneider, W. (1977). Controlled and automatic human information processing: II perceptual learning, automatic attending, and a general theory. *Psychological Review*, 84(2):127–90.
- Spratling, M. W. (2008). Reconciling predictive coding and biased competition models of cortical function. *Frontiers in Computational Neuroscience*, 2(4):1–8.
- Spratling, M. W., De Meyer, K., and Kompass, R. (2009). Unsupervised learning of overlapping image components using divisive input modulation. *Computational Intelligence and Neuroscience*, 2009(381457).
- Spratling, M. W. and Johnson, M. H. (2001). Dendritic inhibition enhances neural coding properties. *Cerebral Cortex*, 11(12):1144–9.
- Spratling, M. W. and Johnson, M. H. (2002). Pre-integration lateral inhibition enhances unsupervised learning. *Neural Computation*, 14(9):2157–79.
- Spratling, M. W. and Johnson, M. H. (2003). Exploring the functional significance of dendritic inhibition in cortical pyramidal cells. *Neurocomputing*, 52-54:389–95.
- Spratling, M. W. and Johnson, M. H. (2004). A feedback model of visual attention. *Journal of Cognitive Neuroscience*, 16(2):219–37.
- Spruston, N. (2008). Pyramidal neurons: dendritic structure and synaptic integration. *Nature Reviews Neuroscience*, 9:206–21.
- Srinivasan, M. V., Laughlin, S. B., and Dubs, A. (1982). Predictive coding: A fresh view of inhibition in the retina. *Proceedings of the Royal Society of London. Series B, Biological Sciences*, 216(1205):427–59.
- Sripati, A. P. and Johnson, K. O. (2006). Dynamic gain changes during attentional modulation. *Neural Computation*, 18:1847–67.
- Thorpe, S. J. (1995). Localized versus distributed representations. In Arbib, M. A., editor, *The Handbook of Brain Theory and Neural Networks*, pages 549–52. MIT Press, Cambridge, MA.
- Treisman, A. (1996). The binding problem. *Current Opinion in Neurobiology*, 6:171–8.
- Treisman, A. (1998). Feature binding, attention and object perception. *Philosophical Transactions of the Royal Society of London. Series B*, 353(1373):1295–1306.
- Treisman, A. M. (1969). Strategies and models of selective attention. *Psychological Review*, 76:282–99.
- Treisman, A. M. and Gelade, G. (1980). A feature-integration theory of attention. *Cognitive Psychology*, 12:97–136.
- Treue, S. (2001). Neural correlates of attention in primate visual cortex. *Trends in Neurosciences*, 24(5):295–300.
- Treue, S. and Martinez-Trujillo, J. C. (1999). Feature-based attention influences motion processing gain in macaque visual cortex. *Nature*, 399(6736):575–9.
- Tsotsos, J. K., Culhane, S. M., Winky, Y. K. W., Yuzhong, L., Davis, N., and Nuflo, F. (1995). Modeling visual attention via selective tuning. *Artificial Intelligence*, 78(1-2):507–45.
- Usher, M. and Niebur, E. (1996). Modeling the temporal dynamics of IT neurons in visual search: a mechanism for top-down selective attention. *Journal of Cognitive Neuroscience*, 8(4):311–27.
- Vecera, S. P. (2000). Toward a biased competition account of object-based segregation and attention. *Brain and Mind*, 1:353–84.
- von der Malsburg, C. (1995). Binding in models of perception and brain function. *Current Opinion in Neurobiology*, 5(4):520–6.
- Vossel, S., Thiel, C. M., and Fink, G. R. (2006). Cue validity modulates the neural correlates of covert endogenous orienting of attention in parietal and frontal cortex. *NeuroImage*, 32(3):1257–64.
- Wang, Y., Fujita, I., and Murayama, Y. (2000). Neuronal mechanisms of selectivity for object features revealed by blocking inhibition in inferotemporal cortex. *Nature Neuroscience*, 3(8):807–13.
- Williford, T. and Maunsell, J. H. R. (2006). Effects of spatial attention on contrast response functions in macaque area V4. *Journal of Neurophysiology*, 96:40–54.
- Wolfe, J. M. (1994). Guided search 2.0: A revised model of visual search. *Psychonomic Bulletin and Review*, 1(2):202–38.
- Womelsdorf, T., Anton-Erxleben, K., Pieper, F., and Treue, S. (2006). Dynamic shifts of visual receptive fields in cortical area MT by spatial attention. *Nature Neuroscience*, 9:1156–60.
- Wright, M. J., Geffen, G. M., and Geffen, L. B. (1995). Event related potentials during covert orientation of visual attention: effects of cue validity and directionality. *Biological Psychology*, 41(2):183–202.