



King's Research Portal

[Link to publication record in King's Research Portal](#)

Citation for published version (APA):

Schlemper, J., Oksuz, I., Clough, J. R., Duan, J., King, A. P., Schnabel, J. A., Hajnal, J. V., & Rueckert, D. (2019). dAUTOMAP: decomposing AUTOMAP to achieve scalability and enhance performance. *conference abstracts of ISMRM*.

Citing this paper

Please note that where the full-text provided on King's Research Portal is the Author Accepted Manuscript or Post-Print version this may differ from the final Published version. If citing, it is advised that you check and use the publisher's definitive version for pagination, volume/issue, and date of publication details. And where the final published version is provided on the Research Portal, if citing you are again advised to check the publisher's website for any subsequent corrections.

General rights

Copyright and moral rights for the publications made accessible in the Research Portal are retained by the authors and/or other copyright owners and it is a condition of accessing publications that users recognize and abide by the legal requirements associated with these rights.

- Users may download and print one copy of any publication from the Research Portal for the purpose of private study or research.
- You may not further distribute the material or use it for any profit-making activity or commercial gain
- You may freely distribute the URL identifying the publication in the Research Portal

Take down policy

If you believe that this document breaches copyright please contact librarypure@kcl.ac.uk providing details, and we will remove access to the work immediately and investigate your claim.

dAUTOMAP: decomposing AUTOMAP to achieve scalability and enhance performance

Jo Schlemper¹ (✉), Ilkay Oksuz², James Clough², Jinming Duan¹, Andrew P. King², Julia A. Schnabel², Jo V. Hajnal³, and Daniel Rueckert¹

¹ Biomedical Image Analysis Group, Imperial College London, UK
 {jo.schlemper11,d.rueckert}@imperial.ac.uk

² School of Biomedical Engineering and Imaging Sciences, King's College London, UK
 {o.oksuz,j.clough,andrew.king,julia.schnabel}@kcl.ac.uk

³ Imaging and Biomedical Engineering Clinical Academic Group, King's College London, UK
 {jo.hajnal}@kcl.ac.uk

Abstract. AUTOMAP [3] is a promising generalized reconstruction approach, however, it is not scalable and hence the practicality is limited. We present dAUTOMAP, a novel way for decomposing the domain transformation of AUTOMAP, making the model scale linearly. We show dAUTOMAP outperforms AUTOMAP with significantly fewer parameters.

1 Introduction

Recently, automated transform by manifold approximation (AUTOMAP) [3] has been proposed as an innovative approach to directly learn the transformation from source signal domain to target image domain. While the applicability of AUTOMAP to a range of tasks has been demonstrated, its practicality remains limited as the required number of parameters scales quadratically with the input size. We present a novel way for decomposing the domain transformation, which makes the model scale linearly with the input size. We term the resulting network *dAUTOMAP* (decomposed - AUTOMAP). We show that, remarkably, the proposed approach outperforms AUTOMAP for the provided dataset with significantly fewer parameters.

2 Methods

Let $\mathbf{x} \in \mathbb{C}^{N \times M}$ be a complex-valued image. The two-dimensional Discrete Fourier Transform (DFT) is given by:

$$\mathbf{y}[k, l] = \sum_{n=0}^N \sum_{m=0}^M \mathbf{x}[n, m] e^{-j2\pi(\frac{nk}{N} + \frac{ml}{M})} \quad (1)$$

Presented at ISMRM 27th Annual Meeting & Exhibition (Abstract #658)

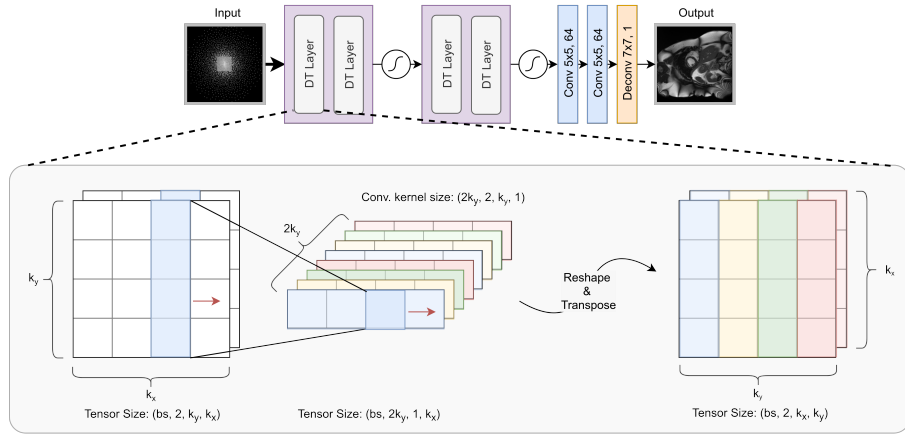

Fig. 1. The proposed network architecture of dAUTOMAP. The network takes k -space data on a Cartesian grid and directly recovers grid and directly recovers the underlying image. The fully-connected layers in AUTOMAP are replaced by decomposed transform (DT) layers, which are fully-connected along one axis. For two-dimensional input, we apply the DT layer twice, once for each axis. Each DT block is activated by ReLU nonlinearity. DT blocks are followed by a sparse convolutional autoencoder, as proposed in [3].

This is commonly written as a matrix product: $\text{vec}(\mathbf{y}) = \mathbf{E}\text{vec}(\mathbf{x})$, where we take row-major vectorization and $\mathbf{E} = e^{-j2\pi(\frac{nk}{N} + \frac{ml}{M})}$, with $p = kM + l$, $q = nM + m$. As the matrix \mathbf{E} is the Kronecker product of two one-dimensional DFT's, we have:

$$\text{Evec}(\mathbf{x}) = (\mathbf{F}_N \otimes \mathbf{F}_M) \text{vec}(\mathbf{x}) = \text{vec}(\mathbf{F}_N \mathbf{x} \mathbf{F}_M^H) = \text{vec}((\mathbf{F}_M (\mathbf{F}_N \mathbf{x})^H)^H), \quad (2)$$

where $(\mathbf{F}_N)_{kn} = e^{-j2\pi\frac{nk}{N}}$, $(\mathbf{F}_M)_{lm} = e^{-j2\pi\frac{ml}{M}}$. Observe that $\mathbf{F}_N \mathbf{x}$ can be computed using a convolution layer with N kernels of size $(N, 1)$ with no padding where the output tensor has size $(N_{\text{batch}}, N, 1, M)$. Motivated by this, we propose a decomposed transform layer (DT layer): a convolution layer with the above kernel size, which is learnable. In the simplest case, the layer can be reduced to the (inverse) Fourier transform or identity. A 2D DFT can be performed by applying the DT layer twice, where the intermediate tensor is first reshaped into $(N_{\text{batch}}, 1, N, M)$ and then conjugate-transposed. Note that the complex nature of the operation is preserved by \mathbb{R}^2 , which doubles the number of output channels (i.e. $2N$). Therefore, the convolution kernel of the DT layer has the shape: $(N_{\text{c_out}}, N_{\text{c_in}}, \text{kernel}_x, \text{kernel}_y) = (2N, 2, N, 1)$. For the second DT layer, N and M are swapped.

The proposed dAUTOMAP, shown in Fig. 1, replaces the fully-connected layers in AUTOMAP by DT layers. We used ReLU as the choice of non-linearity.

Table 1. Quantitative comparison between AUTOMAP and dAUTOMAP. In general, dAUTOMAP outperformed AUTOMAP for Mean Squared Error (MSE), peak signal-to-noise ratio (PSNR), structural similarity (SSIM) and high frequency error norm (HFEN).

N_{grid}	AF	Undersampling	Model	MSE ($\times 10^{-3}$)	PSNR (dB)	SSIM	HFEN
128	7	VDP	AUTOMAP	3.27 \pm 1.17	22.07 \pm 1.35	0.76 \pm 0.03	0.54 \pm 0.07
			dAUTOMAP	1.76\pm0.47	24.67\pm1.14	0.82\pm0.02	0.39\pm0.03
128	4	Poisson	AUTOMAP	3.63 \pm 1.28	21.61 \pm 1.34	0.74 \pm 0.03	0.62 \pm 0.09
			dAUTOMAP	1.54\pm0.43	25.28\pm1.20	0.84\pm0.02	0.40\pm0.03
128	2	Cartesian	AUTOMAP	2.81 \pm 1.35	22.84 \pm 1.64	0.80 \pm 0.03	0.42 \pm 0.07
			dAUTOMAP	1.01\pm0.39	27.2 \pm1.51	0.89\pm0.02	0.27\pm0.05
256	2	Cartesian	AUTOMAP	n/a	n/a	n/a	n/a
			dAUTOMAP	0.51\pm0.25	30.31\pm1.81	0.91\pm0.02	0.29\pm0.04

3 Evaluation

We evaluated the proposed method on a simulation-based study using short-axis (SA) cardiac cine magnitude images from the UK Biobank Study[1] (>1M SA slices). To compare with AUTOMAP, the data were subsampled to central 128 \times 128 k-space grid points. Both methods were evaluated on the reconstruction tasks from three undersampling patterns: (1) Cartesian with Acceleration Factor AF=2, (2) Poisson with AF=4, (3) Variable density Poisson (VDP) with AF=7[2]. For dAUTOMAP, we also experimented with the images having 256 \times 256 k-space grid points, with 2 \times Cartesian undersampling.

Both networks were initialised randomly and trained for 1000 epochs. We used RMSProp with $lr=2\times 10^{-5}$ and Adam optimiser $lr=10^{-3}$ for AUTOMAP and dAUTOMAP respectively. The reconstructions were evaluated by mean squared error (MSE), peak signal-to-noise ratio (PSNR), structural similarity (SSIM) and High Frequency Error Norm (HFEN). We also compared the reconstruction speed and the required parameters.

4 Results

As shown in Table 1, the proposed approach outperformed AUTOMAP (Wilcoxon, $p\ll 0.01$). Fig. 2 shows sample reconstructions. We notice that AUTOMAP tends to over-smooth the image, whereas dAUTOMAP preserves the fine-structure better, even though the residual artefact is more prominent. The result of dAUTOMAP for 256 \times 256 k-space data is shown in Fig. 3, demonstrating that the method successfully learnt a transform which simultaneously dealiases the image. The execution speeds were comparable (Table 2). The parameters of the proposed approach required only 1.5MB of memory for 128 \times 128 k-space data, compared to 3.1GB required for AUTOMAP (these numbers increase to 3.1MB vs 56GB for 256 \times 256 k-space data).

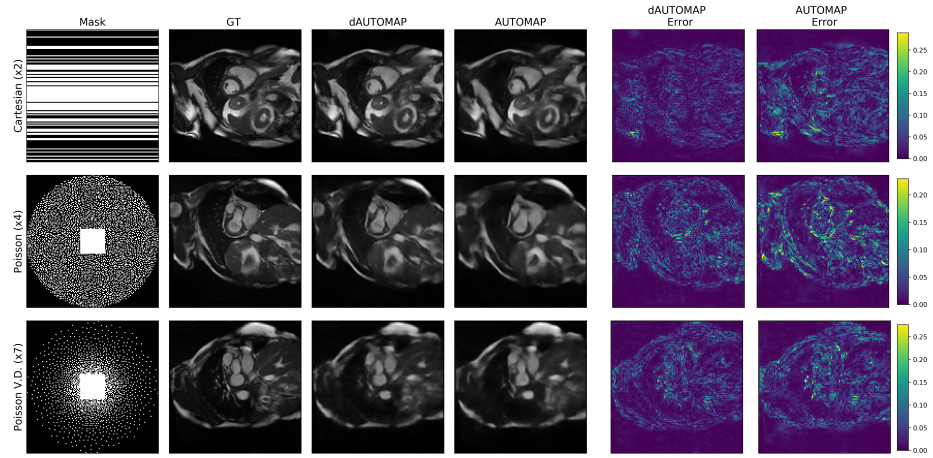

Fig. 2. Reconstruction of AUTOMAP and dAUTOMAP for different undersampling patterns and the resulting error maps. One can see that AUTOMAP tends to over-smooth the edges, which were preserved by dAUTOMAP better.

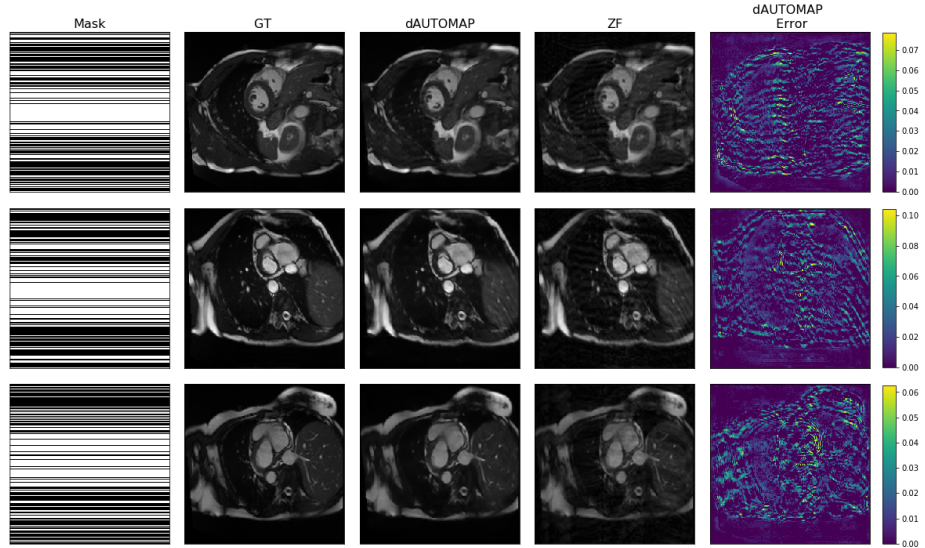

Fig. 3. The sample reconstructions of dAUTOMAP from 256×256 Cartesian k -space data and the corresponding error maps. The majority of the artefacts were removed, however, some high-frequency aliasing can still be observed.

5 Discussion and Conclusion

In this work, we propose a simple architecture which makes AUTOMAP scalable, based on the idea that the original Fourier kernels are linearly separable. We

Table 2. Comparison of the number of parameters and execution speed.

Model	$N_{\text{grid}} = 128$		$N_{\text{grid}} = 256$	
	#Parameters ($\times 10^6$)	Speed (ms)	#Parameters ($\times 10^6$)	Speed (ms)
AUTOMAP	806	0.36 ± 0.36	13000	n/a
dAUTOMAP	0.37	0.48 ± 0.10	1.16	0.50 ± 0.12

experimentally found that such an approach yields superior performance in practice, which is attributed to having significantly fewer parameters, making it easier to train and less prone to overfitting. In future, we plan to investigate the performance of non-Cartesian sampling strategies, which would require regridding, or extensions to 3D data. Finally, the code is available on <http://github.com/js3611/dAUTOMAP>.

6 Acknowledgements

Jo Schlemper is partially funded by EPSRC Grant (EP/P001009/1).

References

- [1] Petersen, S.E., Matthews, P.M., Francis, J.M., Robson, M.D., Zemrak, F., Boubertakh, R., Young, A.A., Hudson, S., Weale, P., Garratt, S., et al.: Uk biobanks cardiovascular magnetic resonance protocol. *Journal of cardiovascular magnetic resonance* 18(1), 8 (2015)
- [2] Uecker, M., Ong, F., Tamir, J.I., Bahri, D., Virtue, P., Cheng, J.Y., Zhang, T., Lustig, M.: Berkeley advanced reconstruction toolbox. In: *Proc. Intl. Soc. Mag. Reson. Med.* vol. 23, p. 2486 (2015)
- [3] Zhu, B., Liu, J.Z., Cauley, S.F., Rosen, B.R., Rosen, M.S.: Image reconstruction by domain-transform manifold learning. *Nature* 555(7697), 487 (2018)