

This electronic thesis or dissertation has been downloaded from the King's Research Portal at <https://kclpure.kcl.ac.uk/portal/>



Reading difficulties and cognitive-neurophysiological impairments in ADHD a focus on development and aetiology

Cheung, Celeste

Awarding institution:
King's College London

The copyright of this thesis rests with the author and no quotation from it or information derived from it may be published without proper acknowledgement.

END USER LICENCE AGREEMENT



Unless another licence is stated on the immediately following page this work is licensed

under a Creative Commons Attribution-NonCommercial-NoDerivatives 4.0 International

licence. <https://creativecommons.org/licenses/by-nc-nd/4.0/>

You are free to copy, distribute and transmit the work

Under the following conditions:

- Attribution: You must attribute the work in the manner specified by the author (but not in any way that suggests that they endorse you or your use of the work).
- Non Commercial: You may not use this work for commercial purposes.
- No Derivative Works - You may not alter, transform, or build upon this work.

Any of these conditions can be waived if you receive permission from the author. Your fair dealings and other rights are in no way affected by the above.

Take down policy

If you believe that this document breaches copyright please contact librarypure@kcl.ac.uk providing details, and we will remove access to the work immediately and investigate your claim.

This electronic theses or dissertation has been downloaded from the King's Research Portal at <https://kclpure.kcl.ac.uk/portal/>

Title: Reading difficulties and cognitive-neurophysiological impairments in ADHD: a focus on development and aetiology

Author: Celeste Cheung

The copyright of this thesis rests with the author and no quotation from it or information derived from it may be published without proper acknowledgement.

END USER LICENSE AGREEMENT



This work is licensed under a Creative Commons Attribution-NonCommercial-NoDerivs 3.0 Unported License. <http://creativecommons.org/licenses/by-nc-nd/3.0/>

You are free to:

- Share: to copy, distribute and transmit the work

Under the following conditions:

- Attribution: You must attribute the work in the manner specified by the author (but not in any way that suggests that they endorse you or your use of the work).
- Non Commercial: You may not use this work for commercial purposes.
- No Derivative Works - You may not alter, transform, or build upon this work.

Any of these conditions can be waived if you receive permission from the author. Your fair dealings and other rights are in no way affected by the above.

Take down policy

If you believe that this document breaches copyright please contact librarypure@kcl.ac.uk providing details, and we will remove access to the work immediately and investigate your claim.

**Reading difficulties and cognitive-neurophysiological
impairments in ADHD: a focus on development and aetiology**

Celeste H. M. Cheung

MRC Social, Genetic and Developmental Psychiatry Centre,
Institute of Psychiatry, King's College London

Thesis submitted for the degree of Doctor of Philosophy

2013

Abstract

This thesis uses a multidisciplinary approach to examine attention-deficit/hyperactivity disorder (ADHD) in the context of development and co-occurring impairments. The first part of the thesis focuses on the co-occurrence between ADHD and reading difficulties, investigating underlying cognitive impairments and their possible shared aetiology. We show, in a clinically ascertained sample, that the shared familial influences on ADHD and reading difficulties are largely independent of familial influences shared with IQ. Using a population-based twin sample, we further show that a significant proportion of the shared genetic influences on inattention symptoms and reading difficulties are captured by the cognitive processes of reaction time variability (RTV) and verbal memory, although the majority of the genetic sharing remains unaccounted for. The second part of the thesis reports findings from a follow-up study of ADHD and control sibling pairs. First, in an investigation of the neurophysiological basis of decreased attentional fluctuation, we show that a fast condition with rewards normalises attention allocation (early-P3 amplitudes) and improves RTV in individuals with ADHD. Second, childhood measures of ADHD symptom severity, socio-economic status, IQ and actigraph movement level predicted ADHD severity in adolescence and young adulthood, whereas other cognitive variables did not. Third, in an investigation of cognitive-neurophysiological markers of ADHD persistence and remittance, the pattern of results was indicative of three processes underlying outcome in ADHD: i) markers of recovery (preparation-attention-vigilance measures); ii) executive control processes (inhibition and working memory) that were not significantly associated with ADHD outcome; and iii) IQ as a potential moderator of ADHD outcome: in addition to childhood IQ predicting future ADHD outcome, it was associated with ADHD symptom improvement at follow up. These findings emphasise the role of IQ in ADHD outcome, and the malleability of the preparation-vigilance-attention processes, which are candidate targets for future development of non-pharmacological interventions.

Statement of work

This thesis focuses on data from three studies: a general population sample of twins (Study of Activity and Impulsivity Levels in children; SAIL), funded by a project grant from the Wellcome Trust to Dr. Jonna Kuntsi (grant number: GR070345MF); a clinically ascertained ADHD-proband and control sibling-pair sample from the International Multicentre ADHD Genetics Consortium (IMAGE), funded by NIMH grant R01062873 to Professor Stephen Faraone (London PI: Professor Philip Asherson), with the London part of this project supported by UK Medical Research Council grant G03001896 to Dr. Jonna Kuntsi. The follow-up project (Sibling EEG Follow-up Study; SEFOS) of the initial IMAGE London sub-sample was supported by generous grants from Action Medical Research and the Peter Sowerby Charitable Foundation (grant reference GN1777).

The present thesis represents my own work. For the quantitative genetics analyses (chapters 2 and 3), I formulated the research questions, conducted the model-fitting analyses and interpreted the output under the supervision of Dr. Alexis Frazier-Wood, Dr. Jonna Kuntsi, Dr. Fruhling Rijdsdijk and Professor Philip Asherson. I was responsible for the smooth running of the follow-up project (SEFOS) (chapters 4, 5 and 6). I conducted clinical assessments and collected all of the cognitive and EEG data, and I was in charge of cleaning and pre-processing the actigraph and EEG data. I was also involved in the project design and concept, performed statistical analyses and interpreted the data under the supervision of Dr. Jonna Kuntsi, Professor Philip Asherson, Dr. Fruhling Rijdsdijk, Dr. Gràinne McLoughlin, Dr. Alexis Frazier-Wood, Professor Daniel Brandeis and Professor Tobias Banaschewski

List of publication relevant to this thesis

Chapter 2 is adapted from:

Cheung, C. H. M., Wood, A. C., Paloyelis, Y., Arias-Vasquez, A., Buitelaar, J. K., Franke, B., et al. (2012). Aetiology for the covariation between combined type ADHD and reading difficulties in a family study: the role of IQ. *J Child Psychol Psychiatry*, 53(8), 864-873.

Chapter 3 is adapted from:

Cheung C. H. M., Fraizer-Wood, A.C., Asherson, P., Rijdsdijk, F., Kuntsi, J. (under review). Shared cognitive impairments and aetiology in inattention and reading.

Chapter 4 is adapted from:

Cheung, C. H. M., McLoughlin G., Brandeis, D., Banaschewski, T., Asherson, P., Kuntsi, J. (under review). A neurophysiological pathway to decreased attentional fluctuation in ADHD.

Chapter 5 is adapted from:

Cheung, C. H. M., Rijdsdijk F., McLoughlin G., Asherson, P., Kuntsi, J. (submitted). Which childhood symptoms, family background and cognitive measures predict future ADHD outcome?

Chapter 6 is adapted from:

Cheung, C. H. M., McLoughlin G., Rijdsdijk F., Brandeis, D., Banaschewski, T., Asherson, P., Rijdsdijk F., Kuntsi, J. (submitted). Cognitive-neurophysiological markers of ADHD persistence and remission.

Acknowledgements

First I need to thank all participants and their families from the IMAGE, SAIL and SEFOS projects, without whom none of this work would have been possible.

I would like to express my deepest gratitude to my first supervisor, Dr. Jonna Kuntsi, for allowing me the opportunity to work on these excellent projects. You have been so supportive, patient and generous with your time, guiding me to be a better writer and a more methodical thinker, I am truly grateful to have you as my supervisor. I would also like to thank my second supervisor, Dr. Gràinne McLoughlin, for her guidance and support on EEG; and Professor Philip Asherson, for providing me with helpful advice and sharing his insightful ideas. Special thanks also to Dr. Alexis Frazier-Wood, who supervised my genetic work from half way across the globe, I especially appreciate your enthusiasm and efficiency, I have learnt so much from you. To Dr. Fruhling Rijdsdijk, thank you for so patiently teaching me genetic modelling and giving me statistical advice; and Professor Daniel Brandeis and Professor Tobias Banachewski for their technical advice on EEG analyses.

A big thank you to Jessica Deadman, Hannah Collyer and Sarah-Jane Gregori, who have worked so hard and had to give up many weekends for testing for the SEFOS project. I would also like to acknowledge the SGDP-EEG team, particularly Dr. Charlotte Tye, for always being there to help and showing me the ways; and Stuart Newman for helping me the endless technical problems. To my office mates, past and present, thank you for making my PhD years fun and eventful. Nick, Nusrat and Sarah, thank you for being such supportive friends and taking time to proofread my thesis.

Finally, I would like to thank my parents, for their love and support, providing me with the best possible education for which I am forever grateful, and for sharing their 'workaholic' genes; my brother, for those sporadic yet useful advice and statistical support; special thanks to the Sharifs and Tatas, especially Reshad and Jammy, for their kindness, care and encouragement over these years, which has given me much strength and happiness.

TABLE OF CONTENTS

Abstract	2
Statement of work.....	3
List of publication relevant to this thesis.....	4
Acknowledgements	5
List of tables	14
List of figures	16
List of abbreviations.....	18
CHAPTER 1 – ATTENTION-DEFICIT/HYPERACTIVITY DISORDER IN THE CONTEXT OF DEVELOPMENT AND CO-OCCURRING DISORDERS	20
1.1 ABSTRACT	20
1.2 INTRODUCTION TO ADHD	20
1.2.1 Diagnostic criteria	21
1.2.2 Epidemiology.....	24
1.2.2.1 Gender differences	25
1.2.2.2 Demographic factors	25
1.2.3 Co-occurring symptoms and disorders	26
1.2.4 Methodological considerations in defining ADHD	27
1.2.4.1 Categorical vs dimensional approach	28
1.2.4.2 Parent, teacher or self-report.....	28
1.2.4.3 Actigraph measures of activity levels	31
1.2.5 Treatment and interventions of ADHD	32
1.2.6 Summary.....	34
1.3 AETIOLOGICAL FACTORS OF ADHD.....	34
1.3.1 Quantitative genetic studies	35
1.3.1.1 The twin method	35

1.3.1.2 Sibling model fitting.....	36
1.3.1.3 Multivariate genetic analysis.....	37
1.3.1.4 Findings from twin and family studies.....	37
1.3.2 Molecular genetic studies	38
1.3.3 Environmental risk factors.....	39
1.3.4 Gene-environment interplay	40
1.3.5 Summary.....	41
1.4 COGNITIVE AND NEUROPHYSIOLOGICAL IMPAIRMENTS IN ADHD	41
1.4.1 Phenotypic studies of cognitive impairments in ADHD.....	42
1.4.1.1 Gender differences	44
1.4.1.2 Symptom dimension and subtype differences.....	45
1.4.1.3 Effects of stimulants, event rate and incentives.....	46
1.4.2 Phenotypic studies of neurophysiological impairments in ADHD.....	47
1.4.2.1 Quantitative EEG	47
1.4.2.2 Event-related potentials	50
1.4.2.3 Gender differences	52
1.4.2.4 Subtype differences	53
1.4.2.5 Effect of mediation, event-rate and incentives	54
1.4.3 Endophenotypes: concept and definitions.....	55
1.4.4 Quantitative genetic studies of cognitive impairments in ADHD.....	55
1.4.5 Quantitative genetic studies of neurophysiological impairments in ADHD	56
1.4.6 Summary.....	57
1.5 THE CO-OCCURRENCE OF READING DIFFICULTIES AND ADHD	58
1.5.1 Phenotypic studies	58
1.5.1.1 Hypotheses for the co-occurrence.....	59
1.5.1.2 The role of IQ	60

1.5.1.3 Shared cognitive impairments.....	61
1.5.2 Quantitative genetic studies	61
1.5.2.1 The role of IQ	62
1.5.2.2 Shared cognitive impairments.....	62
1.5.3 Summary.....	63
1.6 MARKERS AND PREDICTORS OF ADHD OUTCOME	63
1.6.1 Phenotypic studies	64
1.6.1.1 Methodological issues with defining persistence.....	64
1.6.1.2 Childhood predictors of ADHD outcome	67
1.6.1.3 Cognitive markers of ADHD persistence	68
1.6.1.4 Neurophysiological markers of ADHD persistence.....	69
1.6.2 Quantitative genetic studies	70
1.6.3 Summary.....	70
1.7 AIMS AND OBJECTIVES	71
CHAPTER 2 - THE AETIOLOGY FOR THE COVARIATION BETWEEN ADHD AND READING DIFFICULTIES IN A FAMILY STUDY: THE ROLE OF IQ	74
2.1 ABSTRACT.....	74
2.2 INTRODUCTION	75
2.3 METHOD	77
2.3.1 Sample	77
2.3.1.1 ADHD probands and siblings.....	77
2.3.1.2 Control sample	78
2.3.2 Measures.....	79
2.3.3 Analyses	81
2.3.3.1 Multivariate modeling on sibling data.....	81
2.3.3.2 Familial structural equation models (SEM)	83

2.3.3.3 Phenotypic correlation.....	83
2.4 RESULTS	84
2.4.1 Reading difficulties questionnaire (RDQ)	84
2.5 DISCUSSION	90
CHAPTER 3 – SHARED COGNITIVE IMPAIRMENTS AND AETIOLOGY IN INATTENTION AND READING	94
3.1 ABSTRACT.....	94
3.2 INTRODUCTION	95
3.3 METHODS.....	97
3.3.1 Sample and Procedure	97
3.3.2 Measures.....	98
3.3.3 Statistical analyses	101
3.3.3.1 Structural equation models.....	101
3.3.3.2 Univariate genetic models	101
3.3.3.3 Sex effects.....	102
3.3.3.4 Parameter selection for the multivariate models.....	103
3.3.3.5 Multivariate genetic models.....	103
3.4 RESULTS	106
3.4.1 Which cognitive impairments are associated with both ADHD symptoms and RD?	106
3.4.2 To what extent do inattention, RD, RTV, verbal STM and WM share genetic /unique environmental influences?	106
3.4.3 To what extent does a shared cognitive impairment capture the shared genetic risk between ADHD symptoms and RD?.....	107
3.5 DISCUSSION	114

CHAPTER 4 – A NEUROPHYSIOLOGICAL PATHWAY TO DECREASED ATTENTIONAL FLUCTUATION IN ADHD	117
4.1 ABSTRACT.....	117
4.2 INTRODUCTION	118
4.3 METHODS.....	120
4.3.1 Sample	120
4.3.2 Procedure.....	121
4.3.3 Measures.....	121
4.3.4 EEG recording and analysis	123
4.3.5 Statistical analyses	127
4.4 RESULTS	127
4.4.1 RTV	127
4.4.2 Early-P3 (without prestimulus ERP subtraction).....	128
4.4.3 Late-P3.....	128
4.4.4 Prestimulus ERP activity	128
4.4.5 ‘Adjusted’ early-P3 (with prestimulus ERP subtraction).....	129
4.4.6 Relationship between prestimulus ERP activity, early-P3 and RTV	138
4.4.6.1 Correlations.....	138
4.4.6.2 Mediation.....	141
4.5 DISCUSSION	143
 CHAPTER 5 – WHICH CHILDHOOD SYMPTOMS, FAMILY BACKGROUND AND COGNITIVE MEASURES PREDICT FUTURE ADHD OUTCOME?	 146
5.1 ABSTRACT.....	146
5.2 INTRODUCTION	147
5.3 METHODS.....	149
5.3.1 Sample	149

5.3.2 Procedure	153
5.3.2.1 Initial assessment	153
5.3.2.2 Follow-up assessment	153
5.3.3 Measures	153
5.3.3.1 Childhood measures	153
5.3.3.2 Follow-up measures	157
5.3.3.3 Statistical analyses	157
5.4 RESULTS	158
5.4.1 Predictors of ADHD symptoms and impairments	158
5.4.2 Predictors for categorical diagnosis of ADHD persistence	160
5.5 DISCUSSION	171
CHAPTER 6 - COGNITIVE AND NEUROPHYSIOLOGICAL MARKERS OF ADHD PERSISTENCE AND REMISSION	174
6.1. ABSTRACT	174
6.2 INTRODUCTION	175
6.3 METHODS	179
6.3.1 Sample	179
6.3.2 Procedure	180
6.3.3 Measures	181
6.3.4 EEG recording and processing	183
6.3.5 ERP analyses	184
6.3.6 EEG frequency analyses	185
6.3.7 Statistical analyses	185
6.4 RESULTS	187
6.4.1 Which measures show ADHD-control differences at follow-up?	187

6.4.2 Which processes are markers of recovery that distinguish between ADHD persisters and remitters?	188
6.4.3 Which processes are enduring deficits that continue to be impaired in those with childhood ADHD diagnosis, irrespective of current ADHD status?	188
6.4.4 Which processes are associated with continuous trait measures of ADHD symptoms and clinical impairment at follow up within those who had a childhood ADHD diagnosis?.....	189
6.5. DISCUSSION	199
CHAPTER 7 - GENERAL DISCUSSION AND CONCLUSIONS	204
7.1 ABSTRACT.....	204
7.2 AIMS OF THIS THESIS	204
7.3 SUMMARY OF KEY FINDINGS	205
7.3.1 Aetiological covariation between ADHD, reading difficulties and IQ	205
7.3.2 Shared cognitive impairments and aetiology in inattention and reading.....	205
7.3.3 Neurophysiological pathway of reduced attention fluctuation in ADHD	207
7.3.4 Childhood predictors of future ADHD outcome	208
7.3.5 Cognitive and neurophysiological markers of ADHD persistence and remittance.....	209
7.4 WIDER IMPLICATIONS FOR ADHD.....	210
7.4.1 Separation of cognitive impairment factors in ADHD	210
7.4.2 The role of IQ in ADHD	211
7.4.3 Malleable impairments of ADHD	212
7.4.5 Socio-economic background as a risk/protective factor for ADHD outcome	213
7.4.6 Categorical vs dimensional approach to ADHD.....	214
7.4.7 Definition of ADHD persistence	215

7.4.8 Prestimulus baseline subtraction	216
7.5 STRENGTHS AND LIMITATIONS	216
7.5.1 Sample sizes.....	216
7.5.2 Definition of ADHD	217
7.5.3 Age range	218
7.5.4 Measurement and multiple testing issues	218
7.5.5 Effects of medication	220
7.6 FUTURE DIRECTIONS	220
7.6.1 Replication	220
7.6.2 Examining other definitions of ADHD.....	220
7.6.3 Developmental course and outcome of cognitive impairment	221
7.6.4 Very-low frequency oscillations and ADHD.....	221
7.6.5 Familial model fitting analyses	222
7.7 OVERALL CONCLUSION.....	222
References	224
Appendices	260

List of tables

Table 1-1. Diagnostic criteria for ADHD (DSM-IV-TR).....	22
Table 2-1. Means (and standard deviations) for gender, age, IQ and reading difficulties questionnaire (RDQ) in ADHD probands, siblings of ADHD probands and unaffected controls.....	85
Table 2-2. Means and (standard deviation) of gender, age, IQ and TOWRE scores in ADHD probands, siblings of ADHD probands and unaffected controls.....	86
Table 2-3. Maximum likelihood phenotypic (r), familial (rF) and child-specific environmental (rE) correlations across ADHD, IQ, reading difficulties (RD) and TOWRE scores.....	87
Table 3-1. Twin correlations ^a (with 95% confidence intervals), means and standard deviations ^b across inattention (IA), reading difficulties (RD), reaction time variability (RTV), digit span forward (DSF) and digit span backward (DSB)	105
Table 3-2. Phenotypic correlations across inattention (IA), hyperactivity-impulsivity (H-I), reading difficulties (RD), reaction time variability (RTV), commission errors (CE), choice impulsivity (CI), digit span forward (DSF) and digit span backward (DSB)..	108
Table 3-3. Standardised parameter estimates (with 95% confidence intervals) from the correlated factor model across digit span forward (DSF), digit span backward (DSB), reaction time variability (RTV), reading difficulties (RD) and inattention (IA).	109
Table 4-1. Sample characteristics ADHD and controls at follow up	125
Table 4-2. Pearson correlations (two-tailed) between prestimulus activity, unadjusted early-P3 amplitudes (without prestimulus ERP subtraction), adjusted early-P3 amplitudes (with prestimulus ERP subtraction) and reaction time variability (RTV), controlling for effects of age, gender and IQ.	139
Table 4-3. Pearson correlations (two-tailed) between prestimulus activity, unadjusted early-P3 amplitudes (without prestimulus ERP subtraction), adjusted early-P3	

amplitudes (with prestimulus ERP subtraction) and reaction time variability (RTV), without controlling for effects of IQ.....	140
Table 5-1. Sample characteristics between participants (individuals who were successfully reassessed) and non-participants (individuals lost to follow-up).....	151
Table 5-2. Sample characteristics between ADHD persisters and remitters at follow-up.	152
Table 5-3. Predictive values of childhood measures on interview-based ADHD symptoms in adolescence and adulthood.	161
Table 5-4. Predictive value of childhood measures on parent ratings of functional impairment in adolescence/adulthood.	164
Table 5-5. Predictive value of childhood measures on ADHD status (ADHD persisters vs ADHD remitters).....	167
Table 6-1. Group comparison on IQ, digit span, cognitive performance, ERP, EEG and actigraph measures.	191
Table 6-2. Pearson correlations (two-tailed) of IQ, digit span, cognitive performance, ERP, EEG and actigraph measures with interview-based DIVA ADHD symptoms and clinical impairment within the ADHD group only (n=110), without controlling for IQ	197
Table 6-3. Pearson correlations (two-tailed) of digit span, cognitive performance, ERP, EEG and actigraph measures with interview-based DIVA ADHD symptoms and clinical impairment within the ADHD group only (n=110), controlling for IQ	198

List of figures

Figure 2-1 Parameters F1-F3 and parameters E1-E3 are estimates from Cholesky models estimating the familial and child-specific environmental factors across IQ, ADHD and Reading Difficulties Questionnaire (RDQ)..... 88

Figure 2-2. Parameters F1-F3 and parameters E1-E3 are estimates from Cholesky models estimating the familial and child-specific environmental factors across IQ, ADHD and Test of Word Reading Efficiency (TOWRE). 89

Figure 3-1. Unstandardised parameter estimates (G1-G3) from the Cholesky decomposition across reaction time variability (RTV), reading difficulties (RD) and inattention (IA).111

Figure 3-2. Unstandardised parameter estimates (G1-G3) from the Cholesky decomposition across digit span forward (DSF), reading difficulties (RD) and inattention (IA).112

Figure 3-3. Unstandardised parameter estimates (G1-G3) from the Cholesky decomposition across digit span backward (DSB), reading difficulties (RD) and inattention (IA).113

Figure 4-1. An illustration of the temporal sequence of events in the a) baseline and b) fast-incentive conditions of the Fast Task.....126

Figure 4-2. Reaction time performance across the baseline and the fast-incentive conditions (with standard errors) in ADHD (red line) and controls (blue line)130

Figure 4-3. Unadjusted early-P3 amplitudes across the baseline and the fast-incentive conditions (with standard errors) in ADHD (red line) and controls (blue line)131

Figure 4-4. Prestimulus ERP activity across the baseline and the fast-incentive conditions (with standard errors) in ADHD (red line) and controls (blue line)132

Figure 4-5. Adjusted early-P3 amplitudes across the baseline and the fast-incentive conditions (with standard errors) in ADHD (red line) and controls (blue line)133

Figure 4-6. ERP waveforms of the ADHD and control groups in the (a) baseline and (b) fast-incentive conditions.....	134
Figure 4-7. Topographical and t-maps of the early-P3 (250-450ms) (without prestimulus ERP subtraction) in the ADHD and control groups in the baseline and fast-incentive conditions.....	135
Figure 4-8. Topographical and t-maps of the late-P3 (450-600ms) without prestimulus ERP subtraction in the ADHD and control groups in the baseline and fast-incentive conditions.....	136
Figure 4-9. Topographical and t-maps of the prestimulus ERP activity (-200-0ms) in the ADHD and control groups in the baseline and fast-incentive conditions.....	137
Figure 4-10. Neurophysiological pathways to improved RTV. Mediation models in the (a) ADHD and (b) control groups in the fast-incentive condition.....	142
Figure 5-1. Standardised coefficients estimating the relative contribution of each variable on the canonical variates (T1/T2), where T1 reflects the linear combination of the childhood measures and T2 reflects the linear combination of the outcome measures. The relationship between the two canonical variates (T1 and T2) is represented by the canonical correlation	170
Figure 6-1. Waveform ERPs and topographical maps for (a) CNV at central electrode (Cz), and (b) cue-P3 amplitudes at parietal electrode (Pz) in ADHD persisters (red), ADHD remitters (green) and controls (blue).....	194
Figure 6-2. Waveform ERPs and topographical maps for nogo-P3 at central electrode (Cz) in ADHD persisters (red), ADHD remitters (green) and controls (blue).....	195
Figure 6-3. Waveform ERPs and topographical maps for (a) unadjusted early-P3 at and (b) adjusted early-P3 amplitudes at parietal electrode (Pz) in ADHD persisters (red), ADHD remitters (green) and controls (blue).....	196

List of abbreviations

ADHD	Attention-deficit/hyperactivity disorder
ADHD-C	ADHD Combined subtype
ADHD-H	ADHD predominantly Hyperactivity/impulsivity subtype
ADHD-I	ADHD predominantly Inattentive subtype
ASD	Autism spectrum disorder
CD	Conduct disorder
CE	Commission errors
CI	Choice Impulsivity
CNV	Contingent negative variation
CNVs	Copy number variants
CPT	Continuous Performance Test
CTCT	Cross-twin-cross-trait
DAT1	Dopamine transporter gene
DRD4	Dopamine D4 receptor gene
DRD5	Dopamine D5 receptor gene
DSB	Digit span backward
DSF	Digit span forward
DSM	Diagnostic and Statistical Manual
DZ	Dizygotic
EEG	Electroencephalogram
EF	Executive functions
ERP	Event-related potential
FFT	Fast Fourier Transform
GNG	Go/No-Go
GWAS	Genome-wide association studies
ICD	International Classification of Disorders
ISI	Inter-stimulus interval
MPH	Methylphenidate
MRT	Mean reaction time
MZ	Monozygotic
ODD	Oppositional defiant disorder
OE	Omission errors

r_A	Additive genetic correlation
r_F	Familial correlation
r_{ph}	Phenotypic correlation
RD	Reading disability
RTV	Reaction time variability
SES	Socioeconomic status
STM	Short-term memory
WM	Working memory
5HTT	Serotonin transporter gene

CHAPTER 1 – ATTENTION-DEFICIT/HYPERACTIVITY DISORDER IN THE CONTEXT OF DEVELOPMENT AND CO-OCCURRING DISORDERS

1.1 ABSTRACT

The introductory chapter provides a selective overview of attention-deficit/hyperactivity disorder (ADHD) concerning the main issues that are of particular relevance to the aims and research questions of the thesis. The first part of this chapter describes the clinical aspects of ADHD including diagnosis, epidemiology, treatment and co-occurring disorders, followed by a general discussion on the methodological issues and challenges of measuring ADHD symptoms in research. The aetiology of ADHD is also considered, with an overview of the key findings from quantitative genetic studies and molecular genetic studies, followed by a review of the phenotypic and aetiological findings on the cognitive and neurophysiological correlates of ADHD. The chapter then shifts towards more specific areas of this thesis, first by reviewing the key findings on the co-occurrence between ADHD and reading difficulties, and then on the issues regarding the development of ADHD from childhood to adolescence and early adulthood. The chapter concludes with specific research questions and aims of this thesis.

1.2 INTRODUCTION TO ADHD

ADHD is characterised by symptoms of inattention and hyperactivity-impulsivity. The first account of children with behavioural characteristics that resemble aspects of ADHD was reported over three centuries ago by a Scottish physician (Crichton, 1798), who described ‘uncontrollable children’ with predominantly features of inattentiveness (Lange, Reichl, Lange, Tucha, & Tucha, 2010; Palmer & Finger, 2001). A fuller picture of ADHD later emerged from an illustrated children’s story of ‘Fidgety Phil’, which captured the overactive nature of the disorder (Hoffmann, 1985). Following these early observations, efforts were made to refine the definition of ADHD based on empirical

evidence, which brought about the first appearance of ADHD in the Diagnostic and Statistical Manual of Mental Disorder (DSM-II), and was referred to as 'hyperactive child syndrome' (American Psychiatric Association, 1968). The concept of ADHD continued to be refined, resulting in a paradigm shift in the DSM-III, which placed equal emphasis on both inattention and hyperactivity-impulsivity components of the disorder (American Psychiatric Association, 1980). This version also recognised the heterogeneity in behavioural manifestation of the disorder, leading to the definition of subtypes in the subsequent two editions of the DSM (DSM-IV and DSM-IV-TR) (American Psychiatric Association, 1994, 2000). A further revised version of the DSM classification system has been very recently published (DSM-V) (American Psychiatric Association, 2013), in which particular revisions were made to accommodate more appropriate diagnostic criteria for adults with ADHD and acknowledging additional concurrent disorders. However, the research described in this thesis is based on the DSM-IV-TR (described further below).

1.2.1 Diagnostic criteria

Based on the DSM-IV, a child is diagnosed with ADHD if he/she displays six or more out of nine items of inattention and/ or hyperactivity-impulsivity symptoms that persist for at least 6 months and these symptoms are present before the age of seven (Table 1-1). The presence of functional impairment across at least two settings (e.g. at school and at home) is also required, providing that symptoms do not occur exclusively during the course of a pervasive developmental or psychotic disorder, and that they cannot be better explained by another psychiatric disorder (DSM-IV) (American Psychiatric Association, 2000). Adults are only diagnosed with the disorder if they meet criteria for ADHD diagnosis in childhood and continue to show current symptoms and associated impairment of the disorder (Barkley & Murphy, 2006b).

Table 1-1. Diagnostic criteria for ADHD (DSM-IV-TR).

(A1) Inattention: six (or more) of the following symptoms persisting for at least 6 months to a degree that is maladaptive and inconsistent with developmental level:

1. often fails to give close attention to details or makes careless mistakes in schoolwork, work, or other activities
2. often has difficulty sustaining attention in tasks or play activities
3. often does not seem to listen when spoken to directly
4. often does not follow through on instructions and fails to finish schoolwork, chores, or duties in the workplace (not due to oppositional behaviour or failure to understand instructions)
5. often has difficulty organising tasks and activities
6. often avoids, dislikes, or is reluctant to engage in tasks that require sustained mental effort (such as schoolwork or homework)
7. often loses things necessary for tasks or activities (e.g., toys, school assignments, pencils, books, or tools)
8. is often easily distracted by extraneous stimuli
9. is often forgetful in daily activities

(A2) Hyperactivity-impulsivity: six (or more) of the following symptoms persisting for at least 6 months to a degree that is maladaptive and inconsistent with developmental level:

Hyperactivity

1. often fidgets with hands or feet or squirms in seat

2. often leaves seat in classroom or in other situations in which remaining seated is expected
 3. often runs about or climbs excessively in situations in which it is inappropriate (in adolescents or adults, may be limited to subjective feelings of restlessness)
 4. often has difficulty playing or engaging in leisure activities quietly
 5. is often 'on the go' or often acts as if 'driven by a motor'
 6. often talks excessively
-

Impulsivity

7. often blurts out answers before questions have been completed
 8. often has difficulty awaiting turn
 9. often interrupts or intrudes on others (e.g., butts into conversations or games)
-

Other criteria for diagnosis:

- a) some hyperactive-impulsive or inattentive symptoms that caused impairment were present before age 7 years.
 - b) some impairment from the symptoms is present in two or more settings (e.g. at school [or work] and at home).
 - c) there must be clear evidence of clinically significant impairment in social, academic, or occupational functioning.
 - d) the symptoms do not occur exclusively during the course of a Pervasive Developmental Disorder, Schizophrenia, or other Psychotic Disorder and are not better accounted for by another mental disorder (e.g., Mood Disorder, Anxiety Disorder, Dissociative Disorder, or Personality Disorder).
-

DSM-IV distinguishes three subtypes of ADHD: the combined type (ADHD-C) criterion is met when at least six inattention and six hyperactivity-impulsivity symptoms are present; predominantly inattentive type (ADHD-I) when at least six inattention symptoms are present; and predominantly hyperactive-impulsive type (ADHD-H) when at least six hyperactivity-impulsivity symptoms are present.

An alternative diagnostic system that is preferred by some European researchers is the current International Classification of Disease (ICD)-10 (World Health Organisation, 2005). This classification system is more stringent than the DSM-IV, as it excludes children with any co-occurring disorders, and only classifies a child as meeting diagnostic criteria for ADHD if he/she displays symptoms in all three dimensions of inattention, hyperactivity and impulsivity, and meet impairment criteria at home and at school. Therefore, the ICD-10 identifies more severe and rare form of the disorder.

1.2.2 Epidemiology

ADHD affects around 3 to 7 % of school age children worldwide, and is considered one of the most common neurodevelopmental disorders in childhood (Polanczyk, de Lima, Horta, Biederman, & Rohde, 2007; Willcutt, 2012). Although there is evidence for an age-dependent decline in ADHD symptoms, particularly in the hyperactivity-impulsivity symptom dimension (Faraone, Biederman, & Mick, 2006a), epidemiological studies indicate that the prevalence of ADHD remains high, with the most recent meta-analysis reporting a pooled estimate of 2.5% in adult population (Simon, Czobor, Balint, Meszaros, & Bitter, 2009). Compared to the studies in children, the prevalence rates reported in adult literature are more variable (ranging from 1 to 7.3% applying DSM-IV criteria) (Simon et al., 2009). It is also unclear whether the samples included in this meta-analysis are representative of the general population, as the majority of participants included in

these studies were aged between 20 and 30 years, which is lower than that of a typical adult population (Simon et al., 2009).

1.2.2.1 Gender differences

Higher prevalence rates are found among boys (10%) than girls (4%) with ADHD (Polanczyk et al., 2007; Willcutt, 2012). The male-to-female ratio observed in children with ADHD is higher than that reported in adults, suggesting that gender difference in prevalence rates of ADHD could be partly due to rater-bias, with parents and teachers reporting significantly more externalising behaviours in boys, resulting in undiagnosed cases in girls (Brassett-Harknett & Butler, 2007). This is also consistent with the higher number of self-referral cases report in women compared to in girls (Biederman et al., 1994), but these hypotheses do not rule out the possibility that ADHD is more common among boys. The extent to which ADHD in females is just be a 'milder' version of the disorder in males, or whether its manifestation is qualitatively different between gender is still unclear. However, there is some support for ADHD in females to be of a different type with greater complexity, as they exhibit higher rates of internalising problems including anxiety, mood and eating disorder (Quinn, 2011). A meta-analysis also found more females than males meeting diagnostic criteria for ADHD-I, whereas males are more likely to meet criteria for ADHD-C compared to females (Willcutt et al., 2012).

1.2.2.2 Demographic factors

There have been controversies over whether ADHD prevalence is affected by geography and socio-economic status (SES) (Taylor, Sandberg, Thorley, & Giles, 1991). The suspicion that ADHD is an 'American' or 'Western' condition with higher prevalence rates in North American compared to the rest of the world was, however, not supported by findings from meta-analyses that attributed the discrepancies in prevalence between

countries to the differences in diagnostic tools or methodological criterion used (Faraone, Sergeant, Gillberg, & Biederman, 2003; Polanczyk et al., 2007; Willcutt, 2012). Studies have found that individuals in low SES environments were 1.5 to 4 times more likely to meet ADHD criteria compared to those in high SES environments (Amiri, Fakhari, Maheri, & Mohammadpoor Asl, 2010; Costello, Keeler, & Angold, 2001; Dopfner, Breuer, Wille, Erhart, & Ravens-Sieberer, 2008; Froehlich et al., 2007; Graetz, Sawyer, Hazell, Arney, & Baghurst, 2001; Pineda et al., 1999). This finding has not always been consistent, however, (Canino et al., 2004; Nolan, Gadow, & Sprafkin, 2001; Zwirs et al., 2007), highlighting the need for further investigations into the role of SES in ADHD.

1.2.3 Co-occurring symptoms and disorders

ADHD, more often than not, is accompanied by other co-occurring symptoms or disorders (Asherson, 2005). In a recent population-based study of 60,000 US children, of those who had a parent-reported ADHD diagnosis (n=5028), 67% had at least one, concurrent parent-reported diagnosis, compared to 11% of children without ADHD (Larson, Russ, Kahn, & Halfon, 2011). Oppositional defiant disorder (ODD) and conduct disorder (CD) are characterised by defiant behaviors and are more prevalent in boys than in girls (American Psychiatric Association, 2000). ODD/CD co-occur with ADHD in around 30 to 50% of cases in both general population and clinical samples (Biederman, Newcorn, & Sprich, 1991). Findings from meta-analyses of children, adolescents and adults with ADHD indicate that these childhood disorders show stronger associations with hyperactivity-impulsivity than with inattention symptoms (Willcutt, 2012). On the contrary, internalising problems such as anxiety disorder and mood disorders show stronger associations with inattention than with hyperactivity-impulsivity symptoms (Willcutt, 2012; Willcutt et al., 2012). Although these mood-related disorders are often not diagnosed until late adolescence, emotional and social problems, and social

communication difficulties are frequently observed in ADHD during childhood, which reflects the high rates of co-occurrence (20-70%) between ADHD and autism spectrum disorder (ASD) (Banaschewski, Poustka, & Holtmann, 2011; Matson, Rieske, & Williams, 2013).

Children with ADHD frequently experience difficulties at school due to co-occurring reading difficulties (Trzesniewski, Moffitt, Caspi, Taylor, & Maughan, 2006; Willcutt & Pennington, 2000). However, as children with ADHD are also more likely to have lower IQ (Fergusson, Lynskey, & Horwood, 1993; Goodman, Simonoff, & Stevenson, 1995; Kuntsi et al., 2004b; Rapport, Scanlan, & Denney, 1999), it raises the question whether their poor reading performance is partly due to impaired general cognitive abilities. The contribution of IQ to the aetiological overlap between ADHD and reading difficulties is one of the main topics of investigation in this thesis, and is discussed in detail below (see section 1.5 and chapter 2). The effect of low IQ on the developmental course and outcome of ADHD is also a key focus of this thesis (section 1.6 and Chapters 5 and 6).

1.2.4 Methodological considerations in defining ADHD

There are inconsistencies and disagreements on how ADHD should best be defined and measured. Although greater research efforts have been dedicated to understanding the processes underlying ADHD by integrating multiple-level of objective measures such as actigraph or brain measures, these measures have not yet been established as diagnostic tools, and the extent to which these measures can improve the diagnosis of ADHD remains unclear. The issues and complexity of measuring ADHD using informant or self-report, and the potential of using concurrent objective measures in research setting is discussed in the following section.

1.2.4.1 Categorical vs dimensional approach

The categorical classification of ADHD based on standard diagnostic tools such as DSM-IV allows clear communication and consistencies between clinicians, which is necessary for informing diagnosis and treatment (Barkley, 1998; Taylor et al., 1991). The dimensional approach assumes that ADHD represents the extreme end of a normally distributed trait throughout the general population (DeFries & Fulker, 1985). Support for this hypothesis comes from population twin studies that found similarly high estimates of heritability using both a categorical measure of diagnosis and a continuous measure of ADHD symptoms based on rating scales (Chen et al., 2008). There is also evidence for substantial heritability across individuals with varying levels of attention problems including the extreme end of the continuum (Gjone, Stevenson, & Sundet, 1996; Larsson, Anckarsater, Rastam, Chang, & Lichtenstein, 2012). Moreover, longitudinal follow-up studies also reported similar predictive value of both dimensionally defined ADHD 'severity' and categorically defined ADHD 'cases' on adverse outcome (Chen & Taylor, 2005).

Taken together, both dimensional and diagnosis-based categorical approaches of ADHD have strengths and value in understanding the multifactorial and heterogeneous processes underlying ADHD and can complement each other. While the categorical approaches have clear clinical value, the dimensional approach can provide more statistical power for genetic studies (Neale, Eaves, & Kendler, 1994) and minimises the risks of referral bias (Rutter et al., 1990). In this thesis where possible, we examine ADHD using both categorical and dimensional approaches.

1.2.4.2 Parent, teacher or self-report

Studies from the general population commonly measure ADHD symptoms using parent

or teacher ratings or a composite measure of both informants. However, the correlations between the two informant reports of ADHD behaviours are only modest (around $r=0.30$) (Newcorn et al., 1994; Saudino, Ronald, & Plomin, 2005; Thapar, Harrington, Ross, & McGuffin, 2000; Wolraich et al., 2004), indicating modest inter-rater agreement.

The heritability of ADHD based on parent report has shown consistency, whether ADHD is defined categorically or dimensionally (Nikolas & Burt, 2010). However, studies using parent ratings have frequently reported low dizygotic twin (DZ) correlations on ADHD symptoms (smaller than half of monozygotic twin (MZ) correlations) (Kuntsi & Stevenson, 2000, 2001; Martin, Scourfield, & McGuffin, 2002; Saudino et al., 2005; Thapar et al., 2000; Willcutt, Sonuga-Barke, Nigg, & Sergeant, 2008a), which suggests either the presence of dominance genetic or contrast effects, with the latter indicated if there is a significant difference in MZ/DZ variances. Contrast effects can be due either to rater bias, or to true behaviours in the twin pairs (sibling interaction), although findings from structural equation modeling analyses and teacher ratings indicated that contrast effects in ADHD ratings are more often due rater bias (Eaves et al., 2000; Saudino, Cherny, & Plomin, 2000; Simonoff et al., 1998), where parents maximize the difference between their DZ children (Rietveld, Posthuma, Dolan, & Boomsma, 2003a). Contrast effects can also be considered in the co-operative or competitive sense: the former is suggested if increased ADHD scores in one twin leads to higher scores in the co-twin (co-operative), and the latter is indicated if increased ADHD scores in one twin leads to decreased in co-twin scores (competitive). In the case of ADHD ratings, only competitive rater-bias effects have been observed for both maternal and paternal ADHD ratings (Nadder, Silberg, Rutter, Maes, & Eaves, 2001; Saudino et al., 2000; van Beijsterveldt, Verhulst, Molenaar, & Boomsma, 2004), but many studies have found no evidence for contrast effects on parent ADHD ratings (Greven, Asherson, Rijdsdijk, & Plomin, 2011a; Hudziak, Derks, Althoff,

Rettew, & Boomsma, 2005; Larsson, Larsson, & Lichtenstein, 2004; Levy, Hay, McStephen, Wood, & Waldman, 1997; Martin et al., 2002; McLoughlin, Ronald, Kuntsi, Asherson, & Plomin, 2007; Polderman et al., 2007), suggesting that the biases observed could be attributed to differences in rating scale measures or sampling methods (Polderman et al., 2007).

Compared to parent ratings, the heritability estimates of ADHD obtained from teacher reports are more variable (Thapar et al., 2000; Wood, Rijdsdijk, Saudino, Asherson, & Kuntsi, 2008) and are considerably lower ($h^2=0.40$) than those obtained from parent reports ($h^2=0.77$) (Wood et al., 2008), which indicates stronger contribution of environmental factors or measurement error. Therefore, measuring ADHD symptoms based on teacher ratings alone is generally not recommended, and some studies have encouraged the use of an aggregated measure of parent and teacher ratings (Biederman, Faraone, Milberger, & Doyle, 1993; Hartman, Rhee, Willcutt, & Pennington, 2007; Mitsis, McKay, Schulz, Newcorn, & Halperin, 2000). In this thesis, we measured childhood ADHD symptoms in a general population sample of twins using a composite measure of parent and teacher ratings (chapter 3). However, to be consistent with previous analyses (Andreou et al., 2007; Kuntsi et al., 2010; Wood, Asherson, Rijdsdijk, & Kuntsi, 2009a), ADHD diagnostic status in children from the clinical ADHD sample were obtained using structured clinical interviews based on parent report (chapter 2).

In adolescent and adult literature of ADHD, self-ratings are often used for measuring ADHD symptoms. Yet, longitudinal and clinical studies indicate that self-report of ADHD has lower predictive power of outcome, therefore limited clinical utility (Barkley, Fischer, Smallish, & Fletcher, 2002). The low heritability estimates (0-48%) in ADHD obtained from self-report also suggest that this mode of measurement can be unreliable (Martin et

al., 2002; Merwood et al., 2013). Despite low heritabilities observed in self-ratings of ADHD symptoms, a recent study found that the similarities among different ratings are largely (84%) due to common genetic influences (Merwood et al., 2013). In this thesis, we examine the predictive value of parent and teacher ratings of childhood ADHD symptoms on future ADHD outcome separately (chapter 5), as it is unclear whether the two informant measures have the same predictive power on ADHD outcome. To be consistent with the initial assessment in childhood, the diagnostic status at follow up in the adolescent and young adult sample with childhood ADHD was obtained using structured clinical interviews based on parent report (chapters 4, 5 and 6).

Taken together, in comparison to teacher and self-ratings, parent report is likely to be the most reliable source of ADHD-related behaviours, with the highest heritability estimate and predictive validity. However, where possible, combining parent and teacher can also reduce measurement error. Regardless, all informant report is subjected to some degree of bias; therefore it is important to consider alternative objective measures of ADHD symptoms.

1.2.4.3 Actigraph measures of activity levels

A direct approach to objectively quantifying levels of overactivity in ADHD, without bias, is the use of motion detection devices such as actigraphs (Eaton, McKeen, & Saudino, 1996). Previous studies have demonstrated the reliability and validity of this technically simple and inexpensive tool, which showed good discrimination between individuals with and without ADHD (Inoue et al., 1998; McGrath, Handwerk, Armstrong, Lucas, & Friman, 2004; Teicher, Ito, Glod, & Barber, 1996; Wood et al., 2009a). Twin and family studies of children and adults have suggested genetic basis for this measure in both clinical and population-based samples (Ilott, Saudino, Wood, & Asherson, 2010; Teicher

et al., 1996; Wood et al., 2009a; Wood et al., 2008; Wood, Saudino, Rogers, Asherson, & Kuntsi, 2007). Although the phenotypic associations between actigraph measures, parent and teacher report of ADHD symptoms are only modest (around $r_{ph}=0.20$), and the heritability estimates vary across measures ($h^2=0.35$ to 0.70), aggregating three measures resulted in a marked increase in heritability ($h^2=0.92$) in the latent trait (Wood et al., 2008). Around 39% and 21% of genetic influences on actigraph measures were shared with parent and teacher ratings, respectively. Genetic influences on actigraph measures accounted for 95%, 42% and 84% of the covariation with parent ratings, teacher ratings, and combined parent-teacher ratings, respectively (Wood et al., 2008).

Taken together, actigraph measures of activity level show high heritability and reliability, and are informative and objective additions to rating scales or interview-based measures of ADHD. In this thesis, we evaluated the value of actigraph measures in childhood in predicting future ADHD diagnosis and severity (chapter 5), and their ability to discriminate between individuals who 'grow out' of ADHD and those who do not (chapter 6).

1.2.5 Treatment and interventions of ADHD

The efficacy of stimulant medication in reducing ADHD symptoms has been widely documented in both children (Faraone, Biederman, Spencer, & Aleardi, 2006b; Van der Oord, Prins, Oosterlaan, & Emmelkamp, 2008) and adult literature (Faraone & Glatt, 2010; Moriyama, Polanczyk, Terzi, Faria, & Rohde, 2013; Surman, Hammerness, Pion, & Faraone, 2013). Both short- and long-acting stimulants have also demonstrated significantly greater efficacy than nonstimulant medications in both children and adult population (Faraone et al., 2006b; Faraone & Glatt, 2010). Beyond symptom levels, there are also evidence for effects of stimulant medication on cognitive, neurobiological and

neurophysiological functions in moderating ADHD symptoms (Pliszka, 2007). However, the issue concerning long-term risks and side effects remains largely unknown, and other problems including poor compliance, variable prescribing patterns, heterogeneity in treatment response, and the short-lived benefits of medication remain a fundamental drawback of pharmacological treatments in ADHD (Jensen et al., 2007).

There has been growing interest in the potential use of EEG neurofeedback treatment as an alternative non-pharmacological intervention for ADHD (Gevensleben et al., 2009; Heinrich, Gevensleben, & Strehl, 2007). Neurofeedback monitors changes in EEG patterns during a visual or auditory dynamic recording as participants engage in tasks that require attention. Changes in EEG activity in the desired direction are then rewarded with visual or auditory feedback. A meta-analysis of 15 studies and 1194 children with ADHD found a large effect size (d) for inattention ($d=1.02$) and impulsivity ($d=0.94$), and moderate effect size for hyperactivity ($d=0.71$) (Arns, de Ridder, Strehl, Breteler, & Coenen, 2009). There is also some evidence to suggest that the positive effects of neurofeedback can be sustained and improved further with time (Heinrich, Gevensleben, Freisleder, Moll, & Rothenberger, 2004; Strehl et al., 2006). Results from a more recent meta-analysis, which applied stricter inclusion criteria (e.g. including only children from age 3 to 18 years and excluding other rare comorbid conditions) and evaluated the efficacy of a wider range of nonpharmacological interventions reported larger effect sizes for neurofeedback training compared to behavioural interventions and cognitive training (Sonuga-Barke et al., 2013). Nonetheless, due to the strict inclusion criteria, these results are based on very few studies (e.g. eight studies on neurofeedback and six studies on cognitive training); therefore the efficacy of these approaches has yet to be confirmed.

1.2.6 Summary

ADHD is one of the most common childhood neurodevelopmental disorders and is often accompanied by other concurrent developmental or psychiatric disorders. There is growing evidence to suggest that ADHD is highly persistent and the majority of children continue to show symptoms and clinical impairment in adolescence and adulthood. Yet, there remain uncertainties on whether the disorder should be perceived as categorical diagnosis or continuum of symptoms, which informant report should be used, the benefits and risks of pharmacological treatment and the efficacy of alternative treatment. Evidence to date supports the use of dimensional approach for measuring ADHD symptoms in the general population, but also emphasises the importance of retaining the categorical diagnosis-based approach. Parent-report or combined parent and teacher ratings are likely to be the most reliable sources of informant for ADHD, but other objective measures of ADHD symptoms such as actigraph should also be considered as additional measures in research. Despite evidence for efficacy in reducing symptoms, medication treatment in children and adults with ADHD has limitations; yet the efficacy of other non-pharmacological interventions such as neurofeedback is still under investigation.

1.3 AETIOLOGICAL FACTORS OF ADHD

A 'prolonged childhood' is a modern phenomenon that has emerged as a result of economic prosperity and industrialisation (Taylor, 2011). The shift of societal demand from agricultural laborers to literate employees of the cities had meant that, since the twentieth century, most children are required to be educated throughout their childhood into adolescence. In some respect, the argument that ADHD is a psychological condition brought about by societal pressure and intolerance for all children to complete standardised schooling in their early years could therefore have some validity. In

In addition to these possible social and psychological contributions, evidence from genetic and brain imaging indicate that ADHD has substantial biological underpinning. This thesis will focus particularly on the aetiological, cognitive and neurophysiological factors of ADHD, and the evidence and key findings for these are reviewed below.

1.3.1 Quantitative genetic studies

1.3.1.1 The twin method

Based on the expected genetic relatedness of family members, quantitative genetic studies estimate how much of the phenotypic variation of an observable trait is attributable to genetic (additive (A) or dominant (D)) influences and environmental factors. The environmental factors are divided into those which make family members similar (shared environment, C) or dissimilar (child-specific environment, E). E influences also encompass measurement error. Classical twin modeling using monozygotic (MZ) and dizygotic (DZ) twin pairs raised together is based on four main assumptions: 1) MZ twins are genetically identical whereas DZ twins share 50% of their segregating alleles. 2) The C influences of MZ and DZ twin pairs are perfectly correlated ($r=1.00$). 3) There is no correlation for either MZ or DZ for E influences ($r=0.00$). 4) The total variance can be accounted for by the influences modeled and is the same for all individuals (e.g. $A+C+E = 1$). These assumptions allow expectations of the variances ($A+C+E$) and covariances in MZ ($A+C$) and DZ pairs ($0.5A+C$) to be formulated. Structural equation modeling programmes then use maximum likelihood estimation to derive the estimates for A, C and E influences, by minimizing the differences between the expectations of the model and the observed variance / covariance structures of the data. Higher MZ compared to DZ correlations indicate A influences, whereas if DZ correlations are higher than half that of MZ twins it would indicate C influences. The remainder ($1-(A+C)$) indicates E influences. This model will be used in Chapter 3, where further details

can be found in section 3.3.3.2.

Non-additive effects represent the interaction between alleles on the same (dominance) or different (epistasis) loci. In twin modeling, this effect is usually referred to as D influences (Rijsdijk & Sham, 2002). D influences are indicated if DZ twin correlations are less than half of the MZ twin correlations (which also mimics contrast effects as discussed in 1.2.4.2). With samples consisting of only twins reared together, there is insufficient statistical information to estimate all possible latent parameters (A, C, D and E influences) (Neale & Cardon, 1992). As C and D are confounded in their expected effect on MZ:DZ correlation ratio, twin studies that model D influences will automatically exclude C and model only A, D and E influences. To distinguish between A and D influences, a large sample is required. Without sufficient sample size broad sense (A+D) heritability is modeled, which would mean that C influences will go undetected. However, in studies that have modeled C influences, the C estimate has been extremely small and often non-significant (Kuntsi et al., 2004b; Kuntsi, Rijsdijk, Ronald, Asherson, & Plomin, 2005b; Nadder, Rutter, Silberg, Maes, & Eaves, 2002; Rietveld, Hudziak, Bartels, van Beijsterveldt, & Boomsma, 2003, 2004; Ronald, Simonoff, Kuntsi, Asherson, & Plomin, 2008; Saudino et al., 2005). In this thesis, as we were unable to distinguish between A and D influences, we modeled broad sense genetic influences.

1.3.1.2 Sibling model fitting

Using the information that siblings reared together share, on average, 50% of their segregating alleles, univariate and multivariate models use within-trait correlations (e.g. IQ of sibling 1 and IQ of sibling 2) and cross-twin/sibling cross-trait (CTCT) correlations (e.g. IQ of sibling 1 and inattention symptoms of sibling 2) to decompose the variation of, and the covariation between traits into familial (F) and E influences. As sibling models

cannot disentangle genetic from environmental sources of transmission, it is assumed that F comprises of between 50-100% of A (as siblings share around 50% of their genetic information, and the remaining comprises also correlation and interaction with the environment) + 100% of C influences. Further details of this model can be found in section 2.3.3.1.

1.3.1.3 Multivariate genetic analysis

In addition to decomposing variance of a single trait into genetic/familial and environmental components, multivariate analysis using genetically informative samples can determine the aetiological sources of covariation between two or more phenotypes based on the CTCT correlations (Posthuma, 2009; Rijdsdijk & Sham, 2002). A larger MZ CTCT correlation vs DZ CTCT correlation would implicate genetic contribution to the covariation between two traits, whereas shared environmental influences is suggested if DZ CTCT correlations are greater than half of the MZ CTCT correlations. The multivariate approaches used in this thesis include the correlated factor solution of the Cholesky Decomposition (Loehlin, 1996) (see section 2.3.3 and 3.3.3 for more details).

1.3.1.4 Findings from twin and family studies

Converging evidence from twin, family and adoption studies indicate that ADHD is a highly heritable disorder, with heritability estimates of around 71 to 90% (Faraone & Biederman, 2005; Faraone et al., 2005; Nikolas & Burt, 2010; Sprich, Biederman, Crawford, Mundy, & Faraone, 2000; Thapar, Holmes, Poulton, & Harrington, 1999). Family studies have also reported a two- to eightfold increase in risks of ADHD among parents and siblings of children with ADHD (who share around 50% of their genetic information), compared with relatives of unaffected controls (Biederman, 2005).

Twin studies of children that have examined the two ADHD symptom dimension separately have found similarly high heritabilities (around 70-80%) for both inattention and hyperactivity-impulsivity, and the genetic correlation (r_A) between the two traits is around 0.55, indicating that over half of the genetic influences on one symptom dimension overlap with those on the other (Greven, Rijdsdijk, & Plomin, 2011c; Levy et al., 1997; McLoughlin et al., 2007; Sherman, Iacono, & McGue, 1997), but also suggests genetic specificity or unique genetic influences on inattention and hyperactivity-impulsivity (Greven et al., 2011c; McLoughlin et al., 2007). The heritability estimates of ADHD symptoms in adults are lower than those observed in children (<50%) (Boomsma et al., 2010; Ehringer, Rhee, Young, Corley, & Hewitt, 2006; Larsson et al., 2012; Martin et al., 2002; Merwood et al., 2013). The low heritability in this older population has been attributed to increased measurement error in self-rating measures (Merwood et al., 2013).

1.3.2 Molecular genetic studies

With the knowledge that ADHD is an inherited disorder, a large body of molecular genetic studies have sought to identify specific risk gene variants that contribute to the aetiology of ADHD either by targeting specific candidate genes (linkage or association studies), or by casting a wide net and searching across the whole genome for common genetic risks (genome-wide association studies, GWAS). The latest meta-analytic review indicated that the most consistently replicated genes using the candidate gene approach are those implicated in the dopaminergic or serotonergic systems (e.g. DAT1, DRD4, DRD5, 5HTT, HTR1B), but the associations between these candidate gene polymorphisms and ADHD are only modest, with odd ratios ranging from 1.12 to 1.33 (Gizer, Ficks, & Waldman, 2009).

GWAS have not yet identified a common variants reaching genome-wide significance level ($p = 5 \times 10^{-8}$) (Franke, Neale, & Faraone, 2009; Stergiakouli & Thapar, 2010). One of the limitations of GWAS is the requirement of extremely large sample sizes to overcome the problem of multiple testing. The lack of success in the search for common variants in ADHD resulted in a growing interest in rare variant such as copy number variants (CNVs). Individuals with ADHD who also have a variety of neuropsychiatric disorders, such as autism and schizophrenia have been found to have increased large (>500kb) and rare CNVs across multiple genes (Glessner et al., 2009; Grozeva et al., 2012; Stergiakouli et al., 2012; Stergiakouli & Thapar, 2010; Williams et al., 2012). However, whether these rare CNVs have causal relations with ADHD remains unclear (Thapar, Cooper, Eyre, & Langley, 2013).

Taken together, the genetic architecture of ADHD is complex, and is likely to be due to multiple genes of small effect sizes interacting with other genetic variants and with environmental sources. In spite of evidence for a large genetic component, as the heritability of ADHD is not in unity (i.e. $r < 1$), it is important to also consider other non-inherited factors of ADHD.

1.3.3 Environmental risk factors

A number of environmental factors have been associated with ADHD including maternal smoking and stress, low birth weight, environmental toxins, and nutrition (Thapar et al., 2013). However, it remains a challenge to determine whether these risk factors are causally relate to ADHD, as there are also other potential confounders such as inherited factors (Lahey, D'Onofrio, & Waldman, 2009; Thapar, Cooper, Jefferies, & Stergiakouli, 2012). As the parents provide both the genes and the environment, the association may reflect either direct or indirect effects of familial environment. The environmental factor

that is of particular focus in this thesis is SES, as this has been indicated as a particular important risk and protective factor for ADHD that is also associated with many other factors including increased maternal psychopathology and early deprivation (Rutter et al., 1975).

1.3.4 Gene-environment interplay

There is clear evidence for the genetic basis of ADHD, yet the genetic influences underlying the origins of ADHD are not necessarily the same influences as that contribute to its course and outcome (further discussion found in section 1.6.2); this could be due to the complex interplay between susceptibility genes and environmental risk factors or new genetic influences (Larsson et al., 2004; Thapar, Langley, Asherson, & Gill, 2007). The mechanisms by which this interplay occurs can be through gene-environment correlation (when the exposure to a certain environmental factor is influenced by the genetic make-up of the parent) or gene-environment interaction (genetic factors influence the susceptibility of developing the disorder by altering an individual's sensitivity to the environment).

Environmental risks can also alter the genetic function through epigenetic mechanisms such as histone modification or DNA methylation (Mill & Petronis, 2008). Findings from epigenetic studies indicate that pre- or peri-natal factors acting at key developmental periods can alter epigenetic processes and induce long lasting changes in gene expression and behavioural phenotype (Roth, Lubin, Funk, & Sweatt, 2009). Maternal smoking during pregnancy has been shown to affect child development (Knopik, Maccani, Francazio, & McGeary, 2012) and increases rates of ADHD (Cornelius & Day, 2009; Linnet et al., 2003) with a pooled odds ratio of 2.36 (Langley et al., 2005). Emerging evidence from epigenetic studies indicate that prenatal smoke exposure can

alter DNA methylation and microRNA expression, which is associated with fetal growth restriction and birth weight (Haworth et al., 2013; Suter, Abramovici, & Aagaard-Tillery, 2010; Suter et al., 2011). Although no studies have directly investigated the association between maternal smoking and epigenetic changes in ADHD, a growing body of literature has emphasised the need for future research in this area (Elia, Laracy, Allen, Nissley-Tsiopinis, & Borgmann-Winter, 2012; Knopik et al., 2012; Mill & Petronis, 2008).

1.3.5 Summary

Findings from quantitative and molecular studies demonstrate that ADHD is a highly heritable and genetically complex disorder. Despite a large genetic component, environment influences and the interplay between genes and the environment are also important factors contributing to ADHD. The complex patterns of genetic inheritance involving gene-gene and gene-environment co-actions and interactions, resulting in vast heterogeneity in ADHD and co-occurring symptoms pose a fundamental challenge for the identification of the specific causal risk variants of ADHD.

1.4 COGNITIVE AND NEUROPHYSIOLOGICAL IMPAIRMENTS IN ADHD

There has been growing interest in studying brain-based intermediate phenotypes such as cognitive and neurophysiological functions to better elucidate the pathways and processes underlying ADHD (Castellanos, Sonuga-Barke, Milham, & Tannock, 2006; Castellanos et al., 2005; Rommelse et al., 2008a; Rommelse et al., 2008c). The heterogeneity and complexity of ADHD suggests that there are likely to be multiple pathways underlying ADHD; therefore studying ADHD using multi-levels of intermediate measurements is likely an informative approach. Understanding the cognitive and neurobiological processes underlying ADHD may also have clinical implications for prevention, prognosis and interventions. The following two sections provide a brief

overview of phenotypic studies on the key cognitive and neurophysiological impairments in ADHD that are of particular relevance to this thesis.

1.4.1 Phenotypic studies of cognitive impairments in ADHD

ADHD was initially thought of as a deficit of vigilance (Douglas, 1972). The similarities between ADHD symptoms and those of frontal lobe injury led to other early postulations that ADHD is predominantly a disorder of executive dysfunction (Barkley, Grodzinsky, & DuPaul, 1992). However, accumulating evidence indicate that ADHD is associated with multiple domains of cognitive impairment, and cannot be accounted for by a single core deficit. The theoretical models of ADHD have therefore gradually shifted from conceptualising ADHD as disorder with a single core deficit (Barkley, 1997) towards multiple-pathway approaches (Nigg & Casey, 2005; Sagvolden, Johansen, Aase, & Russell, 2005; Sonuga-Barke, 2002; Willcutt et al., 2008a). Some theoretical accounts emphasise particularly the interdependence as well as separation between effortful processes of executive function (EF) and involuntary subcortical processes of arousal and vigilance (Halperin & Schulz, 2006; Halperin, Trampush, Miller, Marks, & Newcorn, 2008; Johnson et al., 2007a; O'Connell et al., 2009a; van de Meer, 2002).

There is an extensive body of research on neuropsychological deficits in children with ADHD, with measures of processing speed, reaction time variability (RTV), response inhibition, working memory and planning amongst the most consistently identified processes that discriminate between children with and without ADHD. In a meta-analytic review of 83 EF studies in ADHD, the effect sizes (d) were moderate between children with and without ADHD, ranging from 0.40 and 0.60 for all EF measures including inhibition, working memory, cognitive shifting and interference control (Willcutt, Doyle, Nigg, Faraone, & Pennington, 2005a). For non-EF measures, a recent meta-analytic

review of RTV in ADHD reported larger effect sizes (Hedges' $g = 0.76$) in children/adolescents than in adults ($g=0.46$) (Kofler et al., 2013). The findings in adolescents and adults are more limited and less consistent compared to those in children, but the similar pattern of cognitive impairments have been reported in both children and adults with ADHD (Frazier, Demaree, & Youngstrom, 2004; Schoechlin & Engel, 2005; Willcutt et al., 2005a).

One of the most common cognitive tasks employed across studies on ADHD is the continuous performance task (CPT). This task examines vigilance and sustained attention, indicated by the number of omitted responses (omission errors (OE)), as well as measures other components of cognitive performances such as RTV and response inhibition (commission errors (CE)). The differentiation between sustained attention (OE) and response inhibition (CE) in the CPT is similar to that in a Go/No-Go (GNG) task, but the two tasks differ in the ratio of target to nontarget stimuli, where the former is characterised by a low target probability and the latter by a high target probability (Berwid et al., 2005). Hence, CPTs are more sensitive to sustained attention (OE) and vigilance processes, whereas GNG tasks are better at detecting inhibition control (CE).

A meta-analytic review of neuropsychological functions in adults with ADHD reported that around 80% of studies have found significant group differences between adults with ADHD and controls on CE and OE with medium to large effect sizes ($d= 0.50-0.75$), indicating ADHD-related deficits in inhibition and sustained attention, respectively (Hervey, Epstein, & Curry, 2004). Another meta-analysis of 47 CPT studies of children with ADHD included also RT and RTV measures and have found similar effect sizes (d) for RTV (0.56), CE (0.55) and OE (0.62) (Huang-Pollock, Karalunas, Tam, & Moore, 2012). Findings from a study that examined various cognitive measures across a wide range of

cognitive tasks revealed RTV as the measure that best discriminated between individuals with ADHD from control compared to other measures such as CE and OE (Klein, Wendling, Huettner, Ruder, & Peper, 2006).

Other cognitive processes, including IQ, verbal short term (STM) and working memory (WM), are also affected in both children and adults with ADHD (Frazier et al., 2004; Martinussen, Hayden, Hogg-Johnson, & Tannock, 2005). Meta-analyses indicated that children and adults with ADHD have lower full scale IQ ($d=0.61$)(Frazier et al., 2004), and have poorer STM ($d=0.47$) and WM ($d=0.43$) compared to controls (Martinussen et al., 2005). An important issue that often arises in experimental studies of ADHD is whether to control for the effects of IQ on the other cognitive variables. As the low IQ is part of ADHD – there is shared phenotypic variance between ADHD symptoms and IQ – controlling for effects of IQ on these cognitive functions in ADHD therefore could potentially remove part of what we are interested in studying (Miller & Chapman, 2001). On the other hand, twin studies have found the aetiological influences on ADHD and cognitive impairments such as CE, RTV and co-occurring symptoms of reading difficulties, to be largely separate from those on IQ (Paloyelis, Rijdsdijk, Wood, Asherson, & Kuntsi, 2010; Wood, Asherson, van der Meere, & Kuntsi, 2010a). Also, among children, ADHD-control differences on many cognitive variables are not affected by whether or not IQ is controlled for (Kuntsi, Wood, Van Der Meere, & Asherson, 2009; Rapport et al., 2008). However, an empirical approach is to conduct analyses both with and without IQ as a covariate; we adopt such an approach in chapters 4, 5 and 6.

1.4.1.1 Gender differences

Gender is another variable that is routinely covaried for in many psychological studies when the groups differ in gender. However, there is limited data on gender differences of

neurocognitive profile in ADHD, partly owing to small sample sizes with an under-representation of girls. Early evidence indicated that, compared to boys, girls with ADHD have lower IQ (Gaub & Carlson, 1997), but have faster processing speed (Rucklidge & Tannock, 2001) and less inhibition deficits (fewer CPT CE) (Newcorn et al., 2001). However, the majority of studies in ADHD do not find gender differences in cognitive impairments (Seidman, 2006).

1.4.1.2 Symptom dimension and subtype differences

A recent meta-analysis revealed that, compared to hyperactivity-impulsivity symptoms, inattention symptoms show stronger associations with a range of cognitive deficits including IQ, STM, WM, processing speed and RTV (Willcutt, 2012). The associations between hyperactivity-impulsivity symptoms and cognitive weaknesses were no longer significant when inattention symptoms were controlled for (Willcutt et al., 2012), indicating that the phenotypic overlap between the two ADHD dimensions accounted for the majority of variances underlying hyperactivity-impulsivity and these cognitive functions. Besides reward-related processing such as temporal discounting and delay aversion (Scheres, Lee, & Sumiya, 2008), not many other cognitive measures have shown specific associations with hyperactivity-impulsivity (Willcutt, 2012). Consistent with the findings from a dimensional approach, a meta-analysis reported that children and adolescents with ADHD-C and ADHD-I performed more poorly than those with ADHD-H on all neurocognitive measures, and relative to controls the magnitude of impairment was greater in those with ADHD-C than those with ADHD-I (Willcutt et al., 2012). As only a few studies in adults have included groups with ADHD-H, no clear conclusions can be drawn for this older population.

1.4.1.3 Effects of stimulants, event rate and incentives

In an earlier section of this chapter, we discussed the effect of medication on ADHD symptoms (see section 1.2.5). Similarly, there is evidence to suggest that stimulants, particularly methylphenidate (MPH), moderate cognitive deficits observed in children with ADHD (Epstein et al., 2011; Swanson, Baler, & Volkow, 2011). Findings from cross-sectional studies suggest that stimulants improve cognitive performance such as faster stop signal RT and lower RTV (Rhodes, Coghill, & Matthews, 2006; Scheres et al., 2003), but such effects are not observed for inhibition, working memory and planning (Coghill, Rhodes, & Matthews, 2007; Rhodes et al., 2006).

Studies from both a general population and a clinically ascertained ADHD sample have demonstrated an ADHD-sensitive improvement in RTV following the introduction of rewards (with or without additional manipulation of a faster event rate) using the GNG task and the Fast Task (Andreou et al., 2007; Kuntsi et al., 2009; Uebel et al., 2010). The Fast Task (see section 3.3.2.5 for task description) is a four-choice RT task that combines rewards and fast event rate, and specifically rewards a reduction in RTV (unlike GNG tasks that reward inhibition performance). The baseline (slow and unrewarded) condition of the Fast Task have demonstrated sensitivity to ADHD impairment, indicated by significant ADHD and control group differences, with the ADHD group showing greater-than-expected reduction in RTV in the fast-incentive condition (with the introduction of rewards and faster event rate) (Andreou et al., 2007; Kuntsi et al., 2009). While studies that have examined the effects of rewards and event rate manipulation separately have found rewards leading to a greater improvement in RTV (Banaschewski et al., 2012; Kuntsi et al., 2009; Uebel et al., 2010), recent findings from a genetic study on across both sibling and twin samples indicate that event rate and incentive manipulations have shared aetiology (Kuntsi et al., 2012). The same study also indicated

that the aetiological processes underlying RTV under baseline (slow and unrewarded) conditions of these tasks are shared with those underlying RTV difference scores across conditions, which index an individual's potential for RTV improvement (Kuntsi et al., 2012). For inhibition deficits (CE), individuals with ADHD did not show a greater improvement than controls with event rate manipulation or introduction of rewards in the GNG task in either the population-based or the clinical ADHD sample (Kuntsi et al., 2009).

The findings on RTV are consistent with theoretical models that incorporate arousal regulation processes in ADHD (Halperin & Schulz, 2006; Halperin et al., 2008; Johnson et al., 2007a; O'Connell et al., 2009a; Sergeant, 2005; van de Meer, 2002), which hypothesise that increased RTV reflects difficulties in arousal regulation in ADHD and emphasise the malleability of RTV and its potential of improvement under conditions that elicit an optimal state. Overall, these findings suggest that increased RTV is not a stable deficit in ADHD, and can be improved substantially under conditions of faster event rate and rewards. Such observation is absent for inhibition deficits, suggesting a greater extent of malleability in RTV relative to inhibitory functions in ADHD. Although these effects have not emerged in all studies (Metin, Roeyers, Wiersema, van der Meere, & Sonuga-Barke, 2012; Wiersema, van der Meere, Antrop, & Roeyers, 2006a), the inconsistencies in findings may relate to differences in age or in exact task parameters; an 'optimal' state is challenging to induce.

1.4.2 Phenotypic studies of neurophysiological impairments in ADHD

14.2.1 Quantitative EEG

ADHD is associated with atypical patterns of neural oscillation measured on the scalp, primarily in the frontal regions (Barry, Clarke, & Johnstone, 2003a; Snyder & Hall, 2006).

Oscillations of neural activity can be observed in the electroencephalogram (EEG). Using the Fast Fourier Transform (FFT) algorithm, the strength of the electrical activity (EEG power, μV^2) within a given time can be quantified for specific frequencies (number of oscillations per second), measured in hertz (Hz) where one hertz is equivalent to one oscillation per second. EEG power is traditionally grouped by frequency bands (delta 0.5-3.5Hz; theta 4-7Hz; alpha 7-12Hz and beta 12-30Hz) based on functional interest (Tye, McLoughlin, Kuntsi, & Asherson, 2011). Although the cut-offs of these frequency bands are arguably arbitrary and differ slightly across studies, quantitative EEG studies have demonstrated high test-test reliability of these bands ($r = 0.71-0.95$), particularly for lower frequencies, such as delta and theta bands (Williams et al., 2005). The functions of these EEG frequency bands in relation to ADHD have been inferred from sleep studies, or while participants are at rest with their eyes open or closed in comparison to the task-related activity, or using skin conductance measures of electrodermal activity, and are linked cortical activation, arousal and vigilance (Barry et al., 2003a; Barry et al., 2009a; Barry et al., 2004; Loo et al., 2009).

The developmental patterns of these EEG bands observed in the general population provide further indication of their function in relation to cortical development (Michels et al., 2013). Delta power is the dominant frequency during infancy and declines with age, hence increased delta activity in children and adolescents has been associated with brain immaturity (Hudspeth & Pribram, 1992). Theta power also shows an age-dependent decrease, whereas alpha activity increases from infancy to childhood and declines from age 8 onwards (Michels et al., 2013). Beta activity increases with age and shows an increase in power from rest to task activity; therefore increased beta is thought to reflect cortical activation (Michels et al., 2013; Tripp & Alsop, 2001). However, it remains unclear whether these developmental patterns can be generalised to clinical

ADHD population.

Although delta activity has not been the main focus of many studies in ADHD, one recent study that used a novel network analysis approach to study EEG ADHD-control differences in EEG frequency bands, by modeling the network functional units and the connections between them, identified the delta band as showing the strongest associations with ADHD (Ahmadlou, Adeli, & Adeli, 2012). Other studies have also reported increased delta activity in girls with ADHD compared to controls during rest (Dupuy, Clarke, Barry, McCarthy, & Selikowitz, 2011). Increased frontal midline theta power is one of the most robust findings in children with ADHD (Chabot & Serfontein, 1996; Clarke, Barry, McCarthy, & Selikowitz, 1998, 2001a). Children and adolescents with ADHD show increased theta and alpha and reduced beta activity and reduced skin conductance levels during rest compared to controls, which support the hypothesis that ADHD is associated with cortical underarousal (Barry et al., 2004; Hermens, Kohn, Clarke, Gordon, & Williams, 2005; Lazzaro et al., 1999). However, controversies remain regarding whether theta power represents cortical activation or underactivation, as some studies from the general population have also found increased theta power associated with increased task demand (Jensen & Tesche, 2002; Klimesch, 1999). Some studies have also found increased beta in subgroups of children with ADHD (Clarke, Barry, McCarthy, & Selikowitz, 2001b; Kuperman, Johnson, Arndt, Lindgren, & Wolraich, 1996), and a recent study indicated an association between increased beta power and reduced skin conductance level (hypoarousal) (Clarke et al., 2013), demonstrating the heterogeneity in EEG profiles of ADHD. Case-control studies have reported similar patterns of increased theta activity in children, adolescent and adult samples, indicating that increased theta power is likely to be a stable marker of ADHD (Bresnahan, Anderson, & Barry, 1999; Bresnahan & Barry, 2002).

While the majority of quantitative EEG studies in ADHD have been conducted while participants were at rest, a few studies have examined the EEG patterns both during rest and during cognitive tasks such as the CPT (Loo et al., 2009; Nazari, Wallois, Aarabi, & Berquin, 2011). However, the EEG findings in ADHD during cognitive tasks are far from consistent. In one study, switching from resting state to CPT induced an increase in alpha power in children with ADHD (n=16) whereas the opposite was observed in controls (n=16) (Nazari et al., 2011); yet the small sample sizes indicate that firm conclusions cannot be drawn. In another study that examined the group differences in EEG power between adults (mean age of 45) with ADHD (n=38) and controls (n=42) during rest and during the CPT found no group differences for delta or theta activity, but the ADHD group had reduced alpha and beta activity during both rest and during performance on the CPT (Loo et al., 2009). However, in this study ADHD and control groups did not differ on any cognitive measure, and both groups had higher-than-average IQ scores (mean IQ =116); therefore the degree to which these findings are representative of other ADHD samples have yet to be tested. These inconsistencies in task-related studies highlight the need for future replications of larger sample sizes, particularly in the adolescent and adult populations.

1.4.2.2 Event-related potentials

Event-related potentials (ERPs) measure the average neuronal activity that is time-locked to the presentation of a stimulus, and are therefore ideal for studying the neurophysiological processes underlying the cognitive impairments, in ADHD, such as those of attention and response inhibition. The temporal precision of ERPs also provides additional information on preparatory responses and allows for interpretations of the temporal sequence of neuronal activity before and after the required responses. Similar to EEG oscillatory activity, ERP parameters of cognitive control (response execution or

inhibition) have demonstrated high test-retest ($r > 0.60$) (Fallgatter et al., 2001) and long-term reliability ($r > 0.85$) (Fallgatter, Aranda, Bartsch, & Herrmann, 2002).

ERP studies have often used the cued version of the continuous performance task (CPT-OX) (see section 6.3.3 for task description) to study the electrophysiological correlates of different aspects of cognitive functions including response inhibition (nogo-P3), attention orienting (cue-P3) and response preparation (CNV). Children with ADHD have reduced inhibitory nogo-P3 amplitudes in frontocentral locations, attenuated cue-P3 amplitudes in parietal regions and reduced CNV activity in the frontocentral locations (Banaschewski et al., 2003, 2004; van Leeuwen et al., 1998). The same patterns of reduced activity in nogo-P3, cue-P3 and CNV were also observed in studies of adults with ADHD (McLoughlin et al., 2010; McLoughlin et al., 2011). However, a recent longitudinal study followed up a small sample of children (mean age of 10 years) with ADHD ($n=11$) and controls ($n=12$) into early adulthood (mean age of 21 years) and found only reduced CNV activity, but no attenuation in the cue-P3 amplitudes and nogo-P3 amplitudes in young adults with ADHD (Doehnert, Brandeis, Schneider, Drechsler, & Steinhausen, 2013). Yet it remains uncertain if non-significant results may reflect limited power, due to small sample sizes. The findings on latencies are less robust: while some studies have found reduced cue-P3 latency in ADHD (McLoughlin et al., 2010), this is not consistently observed (Albrecht et al., 2012).

The P3 component has also been widely investigated in other cognitive tasks including traditional GNG or visual/auditory oddball paradigms. This component shows a parietal scalp distribution with sources generated from inferior parietal, temporal and right prefrontal regions (Polich, 2007). The P3 has been hypothesised to reflect a variety of executive and attentional functions including attentional resource allocation or

reorientation, and updating of working memory (Polich, 2007). Children with ADHD show reduced amplitude and increased latency of the P3, indicating inadequate and delayed attentional responses, respectively (Barry, Johnstone, & Clarke, 2003b). A recent meta-analysis also found reduced P3 amplitudes in adults with ADHD compared to controls during target detection with a medium effect size ($d=0.55$), but there were insufficient data on P3 latencies in ADHD (Szuromi, Czobor, Komlosi, & Bitter, 2011).

In addition to abnormalities in neurophysiological preparation, attention and inhibition, children and adults with ADHD also exhibit atypical neural responses following an erroneous response (error-related negativity (ERN)/Ne or Pe amplitudes) (Albrecht et al., 2010; Falkenstein, Hohnsbein, & Hoormann, 1995; McLoughlin et al., 2009). These ERP markers have been hypothesised to index abilities to optimise performance through error monitoring. Reduced N2 amplitudes following stimuli responses, which are thought to reflect performance monitoring (McLoughlin et al., 2009), have also been shown to be reduced in individuals with ADHD compared to controls in some studies (Donkers & van Boxtel, 2004; McLoughlin et al., 2009; Nieuwenhuis, Yeung, van den Wildenberg, & Ridderinkhof, 2003) but not others (Banaschewski et al., 2004; Fallgatter et al., 2004). As performance monitoring in ADHD is not a central focus of this thesis, this topic is not reviewed in detail.

1.4.2.3 Gender differences

Studies of typically developing children have indicated maturational delay in the EEG of girls, which disappears by adolescence (around 12 years) (Dupuy, Barry, Clarke, McCarthy, & Selikowitz, 2013; Dupuy et al., 2011). As boys are overrepresented in the ADHD population, there is limited research on EEG abnormalities in girls and even fewer studies have examined gender differences in EEG patterns of children with ADHD (Clarke

et al., 2003; Dupuy et al., 2013). However, a recent study reported that both boys and girls with ADHD exhibited increased theta activity, but while girls with ADHD also showed elevated delta and total power, increased alpha and reduced beta activity was more prominent in boys with ADHD (Dupuy et al., 2013).

For ERP parameters, while no studies examining gender differences in ADHD using the cued CPT were identified, two studies have examined gender effects on ERP measures using other cognitive tasks. One study that examined the inhibitory N2 on the Stop Signal Task found no evidence for gender effects (Liotti, Pliszka, Higgins, Perez, & Semrud-Clikeman, 2010), while another study found N2 enhancement in boys with ADHD compared to girls following stimulus conflict (Albrecht et al., 2010). In sum, little is known about whether boys and girls with ADHD show differential pattern of deficit in EEG and ERP processing.

1.4.2.4 Subtype differences

Differences in EEG profiles between ADHD subtypes have been investigated by a few studies (Barry, Clarke, Johnstone, McCarthy, & Selikowitz, 2009b; Chabot & Serfontein, 1996; Clarke et al., 1998, 2001a). Overall, individuals with ADHD-C compared to individuals with ADHD-I have more pronounced abnormalities in delta, theta and alpha bands (Barry et al., 2009b; Clarke, Barry, McCarthy, Selikowitz, & Croft, 2002). No studies have reported subtype differences on the ERP measures of preparation, attention, inhibition or performance monitoring (Johnstone & Clarke, 2009; Keage et al., 2008), however, one of these studies with a small sample size (n=15 in each group) did report group differences between ADHD-C and ADHD-I on an early ERP component (N1) during an inhibition task (Johnstone & Clarke, 2009).

1.4.2.5 Effect of mediation, event-rate and incentives

The most robust effect of stimulants on EEG in ADHD is the reduction in theta and increase in beta power following stimulant treatment (Clarke et al., 2002; Loo, Hopfer, Teale, & Reite, 2004). There is also some evidence for increased parietal P3 and inhibitory nogo-P3 amplitudes in children with ADHD following MPH treatment (Seifert, Scheuerpflug, Zillessen, Fallgatter, & Warnke, 2003; Zillessen, Scheuerpflug, Fallgatter, Strik, & Warnke, 2001), indicating that stimulants can improve attentional and inhibitory capacity in ADHD on a neurophysiological level.

In the general population, increased inter-stimulus interval (ISI), which is equivalent to slower event rate, induces larger parietal P3 amplitudes compared to fast event rate (Polich, 2007). This effect has been attributed to relatively smaller electrical potentials produced following short ISI as a result of shorter 'recovery cycle', whereas in conditions with long ISI, the neural system had sufficient time to recover from the previous evoked potential production, hence the ability to generate more resources for the following stimulus presentation (Polich, 2007). One study that examined event rate on the parietal P3 amplitudes in adults with ADHD and controls found group differences only in the slow (8s ISI), but not the fast (2s ISI) condition (Wiersema, van der Meere, Roeyers, Van Coster, & Baeyens, 2006b). The observed effect was attributed to the absence of P3 amplitudes increment in the ADHD group from fast to slow condition, proposed to reflect difficulties with regulating an optimal arousal or energetic state in ADHD (Wiersema et al., 2006b).

Incentives combined with stimulants demonstrated normalising effects on attenuated parietal P3 amplitudes in children with ADHD using a GNG paradigm, where P3 amplitudes were calculated from both go and no-go trials (Groom et al., 2010). However,

in this study incentives alone did not show significant group by condition interaction effect, indicating that incentives resulted in a similar degree of increase in P3 amplitudes in both children with ADHD and controls.

1.4.3 Endophenotypes: concept and definitions

Endophenotypes are objectively measured neurobiological, physiological and cognitive processes that are related to the disorder of interest (Gottesman & Gould, 2003). These markers can either be risk indicators that are correlated with the disorders through pleiotropic genetic effects, or are intermediate phenotypes that lie along the pathway between genetic factors and behavior (Kendler & Neale, 2010). To fulfill the key criteria as candidate endophenotypes of ADHD, they must be 1) associated with the disorder, 2) heritable, 3) stable over time and are present in individuals whether or not the disorder is active, 4) co-segregate within families, 5) found in non-affected family members at a higher rate than the general population (Gottesman & Gould, 2003).

1.4.4 Quantitative genetic studies of cognitive impairments in ADHD

Whether these cognitive deficits show shared familial/genetic influences with ADHD and are therefore candidate endophenotypes can be investigated in family studies that compare the cognitive performance between individuals with ADHD, their unaffected relatives and unaffected controls. This design assumes that these cognitive processes share familial effects with ADHD if nonaffected family members of ADHD probands also show indications of impairment that is intermediate between probands and controls (Bidwell, Willcutt, Defries, & Pennington, 2007). Studies using this approach have reported inhibition deficits (Bidwell et al., 2007; Crosbie & Schachar, 2001a; Doyle et al., 2005; Rommelse et al., 2008a) and increased RTV in nonaffected siblings of ADHD probands (Andreou et al., 2007; Bidwell et al., 2007; Rommelse et al., 2008a) relative to

unaffected controls. However, some studies with large sample sizes ($n > 100$) did not find evidence for EF impairments in parents and siblings of ADHD probands (Nigg, Blaskey, Stawicki, & Sachek, 2004; Seidman, Biederman, Monuteaux, Weber, & Faraone, 2000). This approach is less informative than twin and familial model fitting (section 1.3.1.1 and 1.3.1.2), as it cannot quantify the degree of familial sharing on a trait or the degree of overlap in familial influences between traits (Wood & Neale, 2010).

Familial model fitting analyses from an international collaborative sample of clinical ADHD and control sibling pairs indicated that a significant proportion of familial influences are shared between ADHD and cognitive measures of RTV ($r_F = 0.74$), inhibition (CE; $r_F = 0.45$) and sustained attention (OE; $r_F = 0.48$) (Kuntsi et al., 2010). The shared familial influences on these cognitive measures and ADHD were largely independent of the aetiological influences that were shared with IQ (Wood et al., 2010a). Similar patterns of results emerged using a general population sample of twin pairs, showing substantial shared additive genetic influences between ADHD and MRT ($r_A = 0.70$) and RTV ($r_A = 0.74$), of which 94% were independent of the aetiological influences underlying IQ (Wood et al., 2010a). A recent study that examined the two ADHD symptom dimensions separately found RTV to show stronger genetic association with inattention symptoms ($r_A = 0.64$) than with hyperactivity-impulsivity symptoms ($r_A = 0.31$). However, both symptom dimensions showed low genetic correlations with CE (0.11 for inattention and 0.17 for hyperactivity-impulsivity symptoms) (Kuntsi et al., 2013).

1.4.5 Quantitative genetic studies of neurophysiological impairments in ADHD

Research investigating the aetiological influences on ADHD and neurophysiological measures is limited. Initial findings from a family study of ADHD sibling pairs indicated

significant familial clustering of EEG measures with ADHD for alpha power in the frontal region during cognitive activation (Loo & Smalley, 2008). For ERPs, familial effects with ADHD have been observed for preparatory cue-P3 and CNV, as both children with ADHD and their non-affected siblings showed reduced activity on these measures compared to controls (Albrecht et al., 2012). The same study did not find familial effects for nogo-P3 amplitudes, as non-affected siblings were intermediate and did not differ from either of the other groups (Albrecht et al., 2012).

1.4.6 Summary

The complexity and heterogeneous nature of ADHD, and the accumulating evidence that indicate multiple pathways underlying the disorder, support the value in studying ADHD using multiple levels of objective brain-based measures. ADHD is associated with impairments in both executive (e.g. inhibition and working memory) and nonexecutive (e.g. variability in response speed and choice impulsivity) domains. The phenotypic associations between ADHD symptoms and RTV, inhibition and working memory are partially attributable to shared genes. There is some evidence that cognitive performance may vary as a function of subtype, but there is little evidence for gender differences on cognitive impairment in ADHD. Other factors such as medication and incentives have also been shown to influence cognitive performance in ADHD, with more prominent effects of stimulants and incentives on RTV than on response inhibition. An ADHD-sensitive improvement in RTV under the combined effects of event rate and incentives further demonstrates the malleability of RTV in ADHD.

On a neurophysiological level, ADHD is associated with atypical processing in attentional alerting, orienting and allocation (various P3 components), preparation (CNV), inhibition (nogo-P3) and performance monitoring (N2, ERN/Ne and Pe). During rest and during

cognitive activation, individuals with ADHD also exhibit atypical EEG power in neuronal oscillatory activity of delta, theta, alpha and beta frequency bands, although findings are less consistent on these measures. To date, limited research has examined whether EEG and ERP abnormalities in ADHD differ by gender, but there is some evidence to suggest that individuals with ADHD-C show greater magnitude of EEG impairment than individuals with ADHD-I. Stimulants have been found to moderate atypical EEG and ERP activity in ADHD, with the strongest findings for theta, beta power, parietal P3 and nogo-P3 amplitudes.

1.5 THE CO-OCCURRENCE OF READING DIFFICULTIES AND ADHD

1.5.1 Phenotypic studies

Reading disability (RD) is one of the most common disorders that co-occurs with ADHD (Carroll, Maughan, Goodman, & Meltzer, 2005; Sexton, Gelhorn, Bell, & Classi, 2012). Both disorders are genetically complex, highly heritable and have a high prevalence rate in childhood (Sexton et al., 2012). The two disorders also share common features of low IQ (Frazier et al., 2004; Kuntsi et al., 2004b) and impairment in multiple cognitive domains (Willcutt et al., 2008a). Epidemiological studies from the general population indicate that ADHD and RD co-occur more frequently than expected by chance (expected prevalence of 0.2%) (Carroll et al., 2005; Pastor & Reuben, 2008). One study found prevalence of co-occurring ADHD and learning disorder (inclusive of RD) of around 3.7% (Pastor & Reuben, 2008), while another study with more stringent criteria of RD based on vocabulary and spelling scores found lower prevalence of 0.4% (Carroll et al., 2005). A high degree of overlap is also observed in clinical samples, with around 25 to 45% of children with ADHD also meeting criteria for RD (August & Garfinkel, 1990; Carroll et al., 2005; Dykman & Ackerman, 1991; Semrud-Clikeman et al., 1992). Similar to ADHD, RD can be considered as a categorical diagnosis or as a continuous measure of reading ability

or difficulties (DeFries & Fulker, 1985). Population-based samples that examined the two ADHD symptom dimensions separately have found reading difficulties to correlate more strongly with inattention symptoms than hyperactivity-impulsivity symptoms (Greven, Harlaar, Dale, & Plomin, 2011b; Martin, Levy, Pieka, & Hay, 2006; Paloyelis et al., 2010; Willcutt, Pennington, & DeFries, 2000b; Willcutt, Pennington, Olson, & DeFries, 2007; Willcutt et al., 2008a; Willcutt, Sonuga-Barke, Nigg, & Sergeant, 2008b).

1.5.1.1 Hypotheses for the co-occurrence

Several models have been proposed to explain why ADHD and RD co-occur more frequently than expected by chance. One possible explanation is that they represent two different aspects of the same disorder, but the dissimilarities in brain structural correlates between RD (mainly left temporal and parietal regions) and ADHD (predominantly frontal, striatal and midline cerebellar regions) (Banaschewski et al., 2005), and the specific effect of stimulants and nonstimulant medication (e.g. MPH and atomoxetine) on ADHD symptoms but not on reading performance make this hypothesis unlikely (de Jong et al., 2009; Keulers et al., 2007; Sumner et al., 2009). Based on the findings that some cognitive impairments were only observed in individuals with symptom presentation of both ADHD and RD, but not in those with only one of these conditions, it has also been suggested that the co-occurring condition could represent a separate disorder (Rucklidge & Tannock, 2002). Yet, growing evidence support the 'multiple deficit model', which proposes that the co-occurrence between ADHD and RD is linked by cognitive deficits that are present in both disorders (McGrath et al., 2011; Shanahan et al., 2006; Willcutt, Pennington, Olson, Chhabildas, & Hulslander, 2005b; Willcutt et al., 2008a). This model extends the shared gene account to argue that the genetic risk factors shared by ADHD, RD and their common cognitive deficits increase the susceptibility to both disorders.

However, other explanations could also mimic the shared gene account: methodological issues including referral bias or shared method variance, and the 'phenocopy hypothesis', which argues for a bidirectional relationship between the two disorders whereby problems associated with one exacerbate the presentation of the other (e.g. early attentional problems leading to later reading difficulties, or vice versa) (Hinshaw, 1992; Pennington, Groisser, & Welsh, 1993a). The similarities in findings between clinical and population-based sample and in studies that used both objective and parent ratings of reading difficulties indicate that these methodological artefacts are unlikely to contribute to the co-occurrence between the two disorders (Willcutt et al., 2000b; Willcutt et al., 2007). Further details of these theories are discussed in chapters 2 and 3.

1.5.1.2 The role of IQ

As ADHD and RD are both associated with low IQ, it is important to identify whether the extent to which the co-occurrence between ADHD and RD is due to their common association with IQ on both phenotypic and aetiological levels. Behavioural studies that examined phonological processes between poor readers who show an IQ discrepancy (between their reading ability and IQ) and those who do not have this discrepancy concluded that the co-occurrence between ADHD and RD cannot be due to IQ differences, as both groups of readers (with or without IQ discrepancy) showed similar phonological difficulties and responded to similar types of treatment (Fletcher, Coulter, Reschly, & Vaughn, 2004; Fletcher, Shaywitz, & Shaywitz, 1999). Moreover, controlling for effects of IQ did not diminish the association between ADHD symptoms and reading ability/disability in a population based study that used dimensional approach (Willcutt, Pennington, & DeFries, 2000a), again indicating that IQ cannot account for the co-occurrence between ADHD and RD.

1.5.1.3 Shared cognitive impairments

Children with RD are also impaired in many domains of cognitive functioning that are associated with ADHD. A recent meta-analysis indicates that processing speed, RTV and verbal working memory are amongst the strongest candidates of cognitive impairments shared between ADHD and RD (Willcutt et al., 2008a). While some studies have found inhibition deficits in children with RD (de Jong et al., 2009; Purvis & Tannock, 2000), others suggest that it is a unique feature of ADHD and only present in those with co-occurring symptoms of both disorders (Willcutt et al., 2010). There are also cognitive processes that are unique to RD, amongst which phonological processing is the most consistent finding (Willcutt et al., 2008a).

1.5.2 Quantitative genetic studies

A growing body of research is investigating the aetiological pathway shared between the two disorders, with the hope to better understand the nature of the comorbidity, which may also shed light on the underlying aetiology of each disorder separately. Understanding the relationship between these two disorders, and their relations with cognitive impairments, would be clinically useful for treating individuals who suffer from both disorders.

Twin and family studies to date have suggested that the frequent co-occurrence between ADHD and reading difficulties is largely attributable to shared genetic/familial influences (Light, Pennington, Gilger, & DeFries, 1995; Martin et al., 2006; Paloyelis et al., 2010; Stevenson, 2001; Stevenson et al., 2005; Stevenson, Pennington, Gilger, DeFries, & Gillis, 1993; Trzesniewski et al., 2006; Willcutt et al., 2000b; Willcutt et al., 2007), with reading difficulties showing stronger genetic association with inattention than with hyperactivity-impulsivity symptoms (Paloyelis et al., 2010; Willcutt et al., 2000b; Willcutt

et al., 2007).

1.5.2.1 The role of IQ

As separate disorders, IQ shows substantial genetic overlap with both ADHD (Kuntsi et al., 2004b; Paloyelis et al., 2010; Wood et al., 2009a) and reading difficulties (Gayan & Olson, 2003; Harlaar, Spinath, Dale, & Plomin, 2005; Paloyelis et al., 2010; Tiu, Thompson, & Lewis, 2003; Wadsworth, Olson, & Defries, 2000). The extent to which the aetiological overlap between ADHD and reading difficulties is due to the same aetiological influences underlying IQ was examined in a general population of twins, which found that around 66% of the covariance between inattention symptoms and reading difficulties was driven by aetiological factors that are independent of IQ (Paloyelis et al., 2010). The generalisability of these findings to a clinical sample is one of the research questions of chapter 2, which also includes more objective measures of reading ability in addition to parent ratings.

1.5.2.2 Shared cognitive impairments

The role of cognitive processes in the co-occurrence between ADHD and RD is not well understood. To date, only one twin study has examined the aetiology and shared cognitive deficits between ADHD and RD to identify which cognitive deficits share genetic influences that can account for the comorbidity between ADHD and RD (Willcutt et al., 2010). Common genetic influences that are also shared with slow processing speed accounted for the co-occurrence between ADHD and RD. To the contrary, significant shared genetic influences between ADHD and RD were independent of working memory and inhibition processes (Willcutt et al., 2010).

1.5.3 Summary

ADHD and reading disability (RD) frequently occur together and both are associated with low IQ and specific cognitive deficits. The co-occurrence between ADHD and reading difficulties has been attributed to shared genetic risk factors, and initial findings from a twin study indicate that the genetic influences shared between ADHD and RD are largely independent of those underlying low IQ. However, the extent to which this finding can be generalised to the clinical population is unknown. Some cognitive weaknesses are shared by both ADHD and RD, which raises the question of whether the aetiological influences on these cognitive processes overlap with those shared between ADHD and RD. Initial findings from a twin study indicated that genetic influences on processing speed accounted for the majority of genetic variances on ADHD and RD, but not all cognitive impairments associated with ADHD have been examined. The aetiological relationship and shared cognitive impairments between ADHD and RD is examined in chapter 3.

1.6 MARKERS AND PREDICTORS OF ADHD OUTCOME

ADHD symptoms show an age-dependent decline from childhood to adolescence, but the rate of decline is greater for hyperactivity-impulsive symptoms than for inattentive symptoms (Biederman, Mick, & Faraone, 2000; Faraone et al., 2006a). So far in this chapter, we have reviewed findings on behavioural symptoms, aetiology, cognitive and neurophysiological correlates of ADHD from cross-sectional studies. Studies in children, adolescents and adults with ADHD have revealed largely similar patterns across all domains of impairments, demonstrating the chronicity and persistent nature of the disorder. ADHD in childhood is associated with higher rates of co-occurring disorders and more negative outcome (e.g. antisocial behaviour and substance abuse) in adolescence and adulthood, and the majority of individuals with childhood ADHD continue to experience difficulties in many domains of their daily function throughout

their lifespan. For these reasons, it is important to consider ADHD in the context of its developmental course and outcome. In this section, I focus on the developmental transition from childhood to adolescence/early adulthood by first discussing the methodological issues of estimating persistence, as this is critical for interpreting findings from follow-up studies. We then review findings from longitudinal follow-up studies on the developmental patterns of behavioural symptoms, predictors of ADHD outcome, and aetiological, cognitive and neurophysiological markers of ADHD persistence and remittance.

1.6.1 Phenotypic studies

1.6.1.1 Methodological issues with defining persistence

Although the concept of ADHD in adults is now widely acknowledged, initially ADHD was commonly viewed as a disorder limited to childhood (Hill & Schoener, 1996). The rate of persistence varies noticeably across studies: while some studies have reported persistence rates of less than 10% (Mannuzza, Klein, & Addalli, 1991; Mannuzza, Klein, Bessler, Malloy, & LaPadula, 1993), others have reported rates of higher than 80% (Barkley, Fischer, Edelbrock, & Smallish, 1990; Biederman et al., 1996; Hart, Lahey, Loeber, Applegate, & Frick, 1995). Various reasons can account for these inconsistencies including the different diagnostic tool used, duration of follow up, age of the sample at follow up, ADHD subtypes in childhood, and how persistence is defined.

Earlier versions of the classification systems (DSM II and DSM-III) placed more emphasis on hyperactivity-impulsivity symptoms, and as these symptoms diminish earlier and at a steeper rate, the persistence rates reported from studies that used these earlier versions are usually lower (~40%) than those using the DSM-III-R or DSM-IV (~74%) (Faraone et al., 2006a). Estimates of persistence also depend on whether self or informant-report is

used. One study that have used self-reported symptoms on structured interviews have found persistence rate of only 5-6%, whereas when parent reports are used, the estimates were markedly increased to 66% (Barkley et al., 2002). Age and duration of follow are also important factors that can affect persistence rates, as a follow-up group of older participants and/or longer follow-up period is likely to lead to lower persistence rate (Faraone et al., 2006a).

The likelihood of persistence also varies as a function of ADHD subtype. This is consistent with the observation on the developmental trajectory of the two symptoms, in that hyperactivity-impulsivity symptoms show greater developmental decline than inattention symptoms. Individuals with ADHD-C at initial assessment have been reported to be equally likely to meet criteria for ADHD-C and ADHD-I at follow up, while those with childhood ADHD-I are more likely to remit or remain at the same subtype (Willcutt, 2012). The pattern is more unpredictable for ADHD-H, as the sample size for this group is small in all studies. However, there is some evidence to suggest that individuals with childhood ADHD-H diagnosis may be more likely to remit than those with the other two subtypes (Willcutt, 2012).

How 'persistence' is defined is also another important consideration for the varying estimates of persistence. In earlier studies, persistence was defined as a continuation of ADHD symptoms (syndromic persistence) without consideration of functional impairment (Biederman et al., 1996; Biederman et al., 1998). However, it was found that around 20% of children with syndromic persistence showed normalisation of functioning, 60% showed intermediate functioning while 20% continued to function poorly. The non-uniform relationship between ADHD symptom development and functional impairment highlights the need to reconsider how persistence is defined, and

the factors that predict heterogeneity in outcome. Taking functional impairment into account and applying a less stringent definition of persistence, one study found that 85% of individuals continued to show full (80%) or subthreshold (5%) criteria for ADHD in early adulthood (Biederman et al., 1996). In a more recent study of 126 adolescents with ADHD (aged 12-18), 70% continued to meet full DSM-IV criteria at follow up. The estimates from these studies are higher than those reported in a meta-analysis, which reported that around 62% of children with ADHD continue to be symptomatic (meeting partial diagnostic status) by age 25, and only 19% met full diagnostic criteria (Faraone et al., 2006a).

The inconsistency in persistence estimates between studies highlights the problem of defining ADHD status using a categorical approach based on arbitrary cut-offs that cannot distinguish individuals who fall just below the diagnostic threshold from those who exhibit very few symptoms. Therefore, while it is helpful to make categorical separations for clinical purposes, studying ADHD symptoms and impairment as a continuous measure is an additional important approach in research.

Taken together, while the majority of individuals continue to show ADHD symptom or related functional impairment in adolescence and adulthood, there is evidently a subgroup of individuals who remit from symptoms and no longer show functional impairment in adolescence and adulthood. This raises the question of what factors in childhood, or during the transition from childhood to adolescence and adulthood, determine whether or not a child remains symptomatic or functionally impaired. Risk or protective factors that are associated with ADHD outcome could be potential moderators of ADHD outcome, and have implications for prevention and prognosis of the disorder. Factors that are associated with the improvement of ADHD could be candidate mediators

of ADHD outcome, potentially also informing the development of intervention methods.

1.6.1.2 Childhood predictors of ADHD outcome

The majority of the prospective studies of childhood predictors have focused on behavioural and environmental measures, in which the severity of ADHD symptoms in childhood, the presence of other co-occurring symptoms such as conduct disorder, low SES and maternal psychopathology have been reported to predict poorer ADHD outcome (Biederman et al., 1996; Biederman, Petty, Clarke, Lomedico, & Faraone, 2011; Hart et al., 1995; Lara et al., 2009; Loney, Kramer, & Millich, 1981; Molina et al., 2009). Six studies on four independent samples have examined the predictive value of cognitive measures in childhood on future ADHD diagnosis or symptoms. However, the age of initial assessments amongst these studies was very young (3 to 6 years of age), and the follow-up duration of these studies was also short (between 4 months to 3 years) (Berlin, Bohlin, & Rydell, 2003; Brocki, Eninger, Thorell, & Bohlin, 2010; Brocki, Nyberg, Thorell, & Bohlin, 2007; Kalff et al., 2005; Kalff et al., 2002; Wahlstedt, Thorell, & Bohlin, 2008). Predictive value was found for WM (Wahlstedt et al., 2008); inhibition (Berlin et al., 2003; Brocki et al., 2010; Brocki et al., 2007; Wahlstedt et al., 2008) and RTV (Kalff, 2005). Lower IQ has also been shown to predict poorer ADHD outcome in some studies (Brocki et al., 2007; Molina et al., 2009) but not in others (Langley et al., 2010).

Taken together, these studies suggest that childhood cognitive variables in very young children have some predictive value for future ADHD outcome a few years later. However, the question of whether this finding can be generalised to adolescents and adults with ADHD is yet to be addressed. Following up children with ADHD-C six years after their initial assessment, the predictive value of childhood behavioural, cognitive and family factors for future ADHD outcome in adolescents and young adults with ADHD is

examined in chapter 5.

1.6.1.3 Cognitive markers of ADHD persistence

The developmental model (Halperin & Schulz, 2006; Halperin et al., 2008) hypothesised that cognitive impairments associated with ADHD are caused by both subcortical and non-cortical abnormalities (e.g. basal ganglia, cerebellum, striatum). Subcortical deficits were proposed as primary deficits that emerge early in life, being relatively stable and not associated with symptom remission. In contrast, prefrontal structures and other prefrontal-mediated circuits that emerge later in development and require high levels of 'effortful control' were hypothesized to be associated with symptom remission. Based on this model, effortful processes of executive functioning should have high predictive value whereas involuntary subcortical functions should not predict future ADHD outcome. Consistent with this theory, the rates of persistence observed for EF deficits resembled those observed for the behavioural symptoms (Biederman et al., 2007), and longitudinal MRI studies also indicated an association between cortical development and clinical outcome of ADHD (Shaw et al., 2007; Shaw et al., 2006). A follow-up study also reported significant group differences between ADHD remitters and controls on proposed bottom-up subcortical measures of arousal regulation (e.g. RTV; also actigraph movement count), but not top-down cortical control measures of inhibition (Halperin et al., 2008), suggesting that despite behavioural improvement, ADHD remitters remain impaired in bottom-up subcortical functions but no longer show impairments in executive control functions. However, it should be noted that this study did not draw direct comparisons between ADHD persisters and remitters as the sample size of the remittent group was thought to be too small (n=29).

Although there was initial support for this theory, more recent findings have been

inconsistent and inconclusive. A recent meta-analysis found no group differences between ADHD persisters and remitters on either executive cortical control or non-executive processes (van Lieshout, Luman, Buitelaar, Rommelse, & Oosterlaan, 2013). ADHD-persistent and control group differences were observed on all measures, but ADHD remitters were generally intermediate between persisters and controls on measures of inhibition, working memory, IQ and RTV. The authors of this meta-analysis suggested the possibility that these cognitive measures are risk indicators of ADHD, rather than mediating the causal pathway between aetiology and behavioural symptoms of ADHD. However, the findings from this meta-analysis should be interpreted with caution, as there was heterogeneity in study designs between studies including age at initial assessment, follow up duration and cognitive tasks used.

1.6.1.4 Neurophysiological markers of ADHD persistence

To date, no longitudinal study has examined the differences in EEG or ERP patterns between ADHD persisters and remitters. However, two follow-up studies of the same sample have examined the developmental trajectory of inhibitory, preparatory and attentional ERP markers. While inhibitory processes (nogo-P3 amplitudes) showed developmental lag (i.e. the nogo-P3 activity in individuals with ADHD resembled that of younger controls) (Doehnert, Brandeis, Imhof, Drechsler, & Steinhausen, 2010), ERP markers of preparation (CNV) and attention (cue-P3) showed signs of development persistence (Doehnert et al., 2013). Although the sample size for one of these studies was very small (n=11/12; ADHD/controls) and inferences cannot be made about the mediating or compensatory processes of ADHD remittance, these findings suggest that the developmental trajectory of inhibitory function may be separate from those of attention and preparation.

1.6.2 Quantitative genetic studies

As substantial genetic and familial influences are known to contribute to ADHD symptoms throughout the lifespan, it is not surprising that family studies indicate ADHD persistence as highly familial (Biederman et al., 1996; Biederman et al., 1998; Faraone, Biederman, & Monuteaux, 2000). Twin studies that investigated how genetic and environmental influences contribute to the development of ADHD symptoms demonstrated that the stability in ADHD symptoms is largely due to the same genetic effects acting on both time points, suggesting that the same genetic factors influence both ADHD and its developmental course (Larsson, Lichtenstein, & Larsson, 2006). A common genetic component has also been found to influence both inattentive and hyperactivity-impulsivity symptom over time (Larsson et al., 2006). However, new genetic and non-shared environmental effects have also been found to emerge in early adolescence, contributing to the decline in ADHD symptoms (Larsson et al., 2004; Nadder et al., 2002).

1.6.3 Summary

Despite high variability between studies on the persistence rates of ADHD, it is evident that while the majority of children with ADHD continue to be affected by the disorder in adolescence and adulthood, a small group of individuals 'grow out' of the condition. However, the factors that are associated with ADHD remission are not well understood. While some studies have identified the behavioural and environmental risk factors in childhood that predict ADHD persistence, little is known about which cognitive processes in childhood show predictive value for ADHD outcome. Moreover, there are inconsistencies between studies regarding which cognitive processes are associated with ADHD persistence and remittance, suggesting the need for further investigations, in future studies, which may benefit from integrating multiple-levels of measures.

1.7 AIMS AND OBJECTIVES

In this thesis, ADHD is considered within the context of development and co-occurring disorders. Using a multi-disciplinary approach by integrating behavioural, quantitative genetic, cognitive and neurophysiological approaches, we aim to gain a more in depth understanding of the aetiological processes underlying ADHD, its co-occurring symptoms and cognitive impairments, and the mechanisms that contribute to the developmental outcome of ADHD.

1.7.1 Part 1 (chapters 2 and 3)

The first two empirical chapters employ genetically sensitive designs and focus on the aetiological influences underlying the co-occurrence between ADHD and reading difficulties (RD). The first empirical study (chapter 2) examines the extent to which the covariation between ADHD and RD is due to familial influences that are also shared with IQ. Previous findings from an unselected population-based sample found shared genetic influences underlying ADHD inattention symptoms and RD to be largely separate from those on IQ (Paloyelis et al., 2010). This study aims to complement this finding using a clinical sample of children with combined type ADHD to determine whether this finding can be generalised to a clinical group. This study also aims to extend previous work by including both parent ratings of reading difficulties and an objective measure of reading ability.

The second empirical chapter further examines the aetiological relationship between ADHD and RD in relation to other ADHD-related cognitive impairments. Previous studies have indicated common cognitive deficits shared by both disorders, but the aetiology of these shared cognitive impairment in relation to the co-occurrence between ADHD and RD is largely unknown. Using a large sample of twin pairs from the general population,

this study aims to address the gap in existing literature by examining the aetiological relationship between ADHD, RD and potential shared cognitive impairments, and the extent to which the co-occurrence between ADHD and RD is due to genetic influences that are also shared with the cognitive impairments.

1.7.2 Part 2 (chapters 4, 5 and 6)

The second part of the thesis examines the cognitive and neurophysiological markers of ADHD in a follow-up sample of ADHD and control sibling pair. The first chapter (chapter 4) aims to unravel the neurophysiological mechanisms underlying increased RTV and its improvement in ADHD and controls. Taking a more developmental approach, the final two empirical chapters examine factors which may predict ADHD outcome in adolescence and adulthood. First, we evaluate the predictive values of childhood behavioural, cognitive and family factors on ADHD severity and diagnosis at follow up. Second, we aim to identify the behavioural, cognitive and neurophysiological processes that are involved in ADHD persistence and remission. The ultimate goal of this project is to identify potential objective measures that can improve the prediction of clinical outcomes in ADHD, and markers that could be used to guide the development of non-pharmacological interventions.

PART I

Aetiological overlap between ADHD and reading difficulties:
the role of IQ and shared cognitive impairments

CHAPTER 2 - THE AETIOLOGY FOR THE COVARIATION BETWEEN ADHD AND READING DIFFICULTIES IN A FAMILY STUDY: THE ROLE OF IQ

2.1 ABSTRACT

Twin studies using both clinical and population-based samples suggest that the frequent co-occurrence of attention-deficit/hyperactivity disorder (ADHD) and reading disability (RD) is largely driven by shared genetic influences. While both disorders are associated with lower IQ, recent twin data suggest that the shared genetic variability between reading difficulties and ADHD inattention symptoms is largely independent of genetic influences contributing to general cognitive ability. The current study aimed to extend the previous findings that were based on rating scale measures in a population sample by examining the generalisability of the findings to a clinical population, and by measuring reading difficulties both with a rating scale and with an objective task. We investigated the familial relationships between ADHD, reading difficulties and IQ in a sample of individuals diagnosed with ADHD combined type, their siblings and control sibling pairs. We ran multivariate familial models on data from 1789 individuals at ages 6 to 19. Reading difficulties were measured with both rating scale and an objective task. IQ was obtained using the Wechsler Intelligence Scales (WISC-III / WAIS-III). Significant phenotypic (0.20-0.40) and familial (0.30-0.50) correlations were observed among ADHD, reading difficulties and IQ. Yet 53% to 72% of the overlapping familial influences between ADHD and reading difficulties were not shared with IQ. Our finding that familial influences shared with general cognitive ability, though present, do not account for the majority of the overlapping familial influences on ADHD and reading difficulties extends previous findings from a population-based study to a clinically-ascertained sample with combined type ADHD.

2.2 INTRODUCTION

Attention deficit-hyperactivity disorder (ADHD) and reading disability (RD) frequently co-occur: 25 to 40% of individuals with one disorder also meet the diagnostic criteria for the other (August & Garfinkel, 1990; Semrud-Clikeman et al., 1992; Willcutt & Pennington, 2000). This is further evident in studies approaching ADHD symptoms (inattentiveness and hyperactivity-impulsivity) and reading ability/disability as continuous traits in population samples (Gilger, Pennington, & DeFries, 1992; Light et al., 1995; Martin et al., 2006; Paloyelis et al., 2010; Stevenson et al., 2005; Willcutt et al., 2000b; Willcutt et al., 2007). Twin studies on general population samples and samples selected for RD consistently indicate a largely genetic aetiology for the phenotypic association between ADHD symptoms and reading ability/disability (Martin et al., 2006; Paloyelis et al., 2010; Willcutt & Pennington, 2000; Willcutt et al., 2000b; Willcutt et al., 2007).

ADHD and RD are associated with IQ scores that are, on average, 7 to 16 points lower than comparison samples (Crosbie & Schachar, 2001b; Kuntsi et al., 2004a; Mariani & Barkley, 1997; Marzocchi et al., 2008; Rucklidge & Tannock, 2001; Tiffin-Richards, Hasselhorn, Woerner, Rothenberger, & Banaschewski, 2008; Wadsworth, DeFries, Olson, & Willcutt, 2007; Wadsworth et al., 2000). Correlations between continuous ADHD symptom scores and IQ range from -0.20 to -0.40 (Fergusson et al., 1993; Goodman et al., 1995; Kuntsi et al., 2004a; Rapport et al., 1999; Wood, Asherson, van der Meere, & Kuntsi, 2009c). Similarly, correlations between reading ability and IQ range from 0.43 to 0.50 (Harlaar et al., 2005; Haworth et al., 2009) and between reading difficulties and IQ from -0.37 to -0.40 (Cardon, Dially, Plomin, DeFries, & Fulker, 1990; Paloyelis et al., 2010). Correlations between reading difficulties and ADHD inattention symptoms range from 0.28 to 0.51, and between reading difficulties and hyperactivity-impulsivity symptoms

from 0.19 to 0.26 (Martin et al., 2006; Paloyelis et al., 2010; Trzesniewski et al., 2006; Willcutt et al., 2007). For both ADHD and RD, twin studies indicate that the association with IQ is largely due to shared genes (Haworth, Meaburn, Harlaar, & Plomin, 2007; Kuntsi et al., 2004a; Plomin & Kovas, 2005; Polderman et al., 2006; Wood et al., 2010a; Wood et al., 2010b). These findings raise the question of whether the covariation between ADHD and RD is due to specific factors contributing to these deficits, or to possible 'generalist' genes that are involved in both general cognitive processes and reading ability (Haworth et al., 2009). Recent evidence from a population-based twin study suggests that the covariation between ADHD inattention symptoms and reading difficulties is largely independent of the aetiology underlying IQ (Paloyelis et al., 2010). This finding is in line with previous twin analyses, where the genetic relationship between ADHD symptoms and reading difficulties did not change significantly after regressing out IQ (Light et al., 1995; Willcutt et al., 2000b).

This study is a novel extension of the previous population-based twin analyses (Paloyelis et al., 2010) to a clinical sample of diagnosed cases selected for combined type ADHD (ADHD-CT) (Wood et al., 2010a; Wood et al., 2010b), while incorporating both rating scale and objective task measures of reading. Our aim is to investigate the aetiological association between ADHD-CT, reading difficulties and IQ, and specifically the extent to which the familial influences shared between ADHD-CT and reading difficulties are also shared with those on IQ. The focus on familial influences, which refer to the combined effects of genes and shared environment, reflects the sibling design: the sample consists of ADHD-CT sibling pairs (ADHD-C proband and closest-age sibling) and control sibling pairs. In contrast to the well-known twin method, quantitative genetic model-fitting analyses on sibling-pair samples have remained under-utilised (but see (Kuntsi et al., 2010; Wood, Asherson, Rijdsdijk, & Kuntsi, 2009b; Wood et al., 2010b); yet their power

and potential lies in the use of clinically diagnosed probands, rarely available in twin populations in adequate numbers, enabling comparisons across clinically-referred and population-based samples.

It is important to complement previous work on an unselected population twin sample with data from a clinical sample selected for ADHD-C before we can generalise our previous findings to this clinical group. Our previous study used only parent ratings to assess reading difficulties, the present study therefore addressed this possible methodological limitation by taking into account data from both a parent report of reading difficulties and scores on an objective measure of reading ability.

2.3 METHOD

2.3.1 Sample

2.3.1.1 ADHD probands and siblings

Participants were recruited from specialist clinics, through five Centres (Amsterdam and Nijmegen in The Netherlands, UK-London, UK-Southampton and Spain) participating in the International Multicentre ADHD Genetics (IMAGE) project (Chen et al., 2008). All participants were of European Caucasian decent, aged 6 to 19 years. All probands had a clinical diagnosis of DSM-IV ADHD combine type (ADHD-C) and had one or more full siblings available for ascertainment of clinical information. Siblings within the same age range as the ADHD probands were included in the study and were therefore unselected for ADHD status. Exclusion criteria applying to both probands and siblings included autism, epilepsy, IQ<70, brain disorders and any genetic or medical disorder associated with externalising behaviour that might mimic ADHD. Of the 1377 ADHD probands and their siblings who participated, 73 were excluded. Of these, 15 were excluded due to IQ<70; 7 had incomplete IQ data; 33 probands did not meet the ADHD DSM-IV criteria

and a further 18 probands did not meet the ADHD-C criteria. The final sample (Table 2-1) consisted of 1304 individuals, which comprised 615 complete ADHD and sibling pairs and 74 singletons. Singletons are defined as those whose co-siblings had incomplete cognitive or reading data, or were excluded. Singletons were included in our analysis as they provide information on within-subject covariance and therefore increase statistical power. The receiver operating characteristic (ROC) analysis (with 95% sensitivity and specificity) was used to determine the affection status of the siblings of ADHD probands. Those who had a combined parent-rated T-score greater than 137.5 on the Strength and Difficulties Questionnaire (SDQ; (Goodman, 1997; Goodman, Meltzer, & Bailey, 1998) and the Conners ADHD/DSM-IV scale (Conners, Sitarenios, Parker, & Epstein, 1998a) were classified as 'affected'; those who scored between 118.5 and 137.5 were classified as 'subthreshold'; and the remaining who had a score lower than 118.5 were unaffected. Of the 712 individuals with ADHD-C, there was an overlap of comorbid disorders as follows: 180 had conduct disorder, 441 had oppositional defiant disorder, and 143 had evidence of a mood disorder (excluding possible bipolar disorder), as derived using the Parental Account of Child Symptoms (PACS) parental interview (Taylor et al., 1986a; Taylor et al., 1987).

2.3.1.2 Control sample

The control group was recruited from primary (ages 6-11 years) and secondary (ages 12-19 years) schools in the UK and The Netherlands. The same exclusion criteria were applied as for the clinical sample. Nine controls were excluded for having both parent and teacher subscale T scores on the Conners ADHD/DSM-IV Scale (Conners et al., 1998a) greater than 63, to exclude potential undiagnosed ADHD cases. The final control sample consisted of 485 individuals, which comprised 211 sibling pairs and 63 singletons.

2.3.2 Measures

ADHD Diagnosis. All cases were referred from clinics with a diagnosis of ADHD-C. The PACS interview (Taylor et al., 1986a; Taylor et al., 1987) was subsequently conducted with the parents to derive the 18 DSM-IV symptoms for ADHD index cases plus siblings who were thought, on the basis of parents' descriptions of behaviour or Conners' scores of 65 or greater, to have ADHD. The PACS interview is a semi-structured and standardised clinical interview used to obtain an objective measure of child behaviour in a range of specified situations, including home and school. Situational pervasiveness was defined as some symptoms occurring within 2 or more different situations from the PACS, as well as the presence of 1 or more symptoms scoring 2 or more from the DSM-IV ADHD subscale of the teacher-rated Conners subscale (Conners, Sitarenios, Parker, & Epstein, 1998b). Impairment criteria were based on the severity of symptoms identified in the PACS.

IQ. We used the vocabulary, similarities, picture completion and block design subtests from the Wechsler Intelligence Scales for Children, Third Edition (WISC-III) (Wechsler, 1991) or, for participants older than 16 years, the Wechsler Adult Intelligence Scale, Third Edition (WAIS-III) (Wechsler, 1997b). These subtests correlate between 0.90 and 0.95 with the full-scale IQ (Groth-Marnat, 1984).

Reading difficulties. Reading Difficulties Questionnaire (RDQ) is a subscale of the Colorado Learning Difficulties Questionnaire (CLDQ) (Willcutt et al., 2011a). This 6-item parent rating scale is part of an instrument screening for learning disorders. On a scale which ranges from 1 (Never/ not at all) to 5 (Always/ a great deal), parents reported the extent of their child's difficulties with spelling, learning letter names, sounding words out, and to what extent their child reads slowly, below expectancy level or has required

extra help at school. The total score ranges from 5 to 30, with higher scores indicating greater difficulties with reading. This scale has been shown to have excellent internal consistency (mean Cronbach's $\alpha = 0.90$) and high inter-rater ($r = 0.83$) and one-year test-retest reliabilities ($r = 0.81$) (Willcutt et al., 2011a). RDQ has shown high correlations with other objective reading and spelling measures (average $r = 0.64$) but low correlations with measures of other learning difficulties ($r = 0.07$ to 0.02), which attest to its good criterion and discriminant validity (Willcutt et al., 2011a). Moreover, RDQ scores have demonstrated moderate to high heritability ($h^2 = 53$ to 83%) and high genetic correlations (0.71 to 0.89) with a composite measure of reading performance (Astrom, DeFries, Pennington, Wadsworth, & Willcutt, 2009; Martin et al., 2006).

Reading fluency. Test of Word Reading Efficiency (TOWRE) (Torgesen, Wagner, & Rashotte, 1999). This is a standardised measure of fluency and accuracy in word reading skill. It includes two subtests: (a) Sight-word Efficiency (SWE), a measure of accuracy and fluency in reading regular and irregular words, based on the ability to read aloud accurately a graded list of 104 real words in 45 seconds. The total raw score on this subtest ranges from 0 to 104; (b) Phonemic Decoding Efficiency (PDE), a measure of phonological awareness, based on the ability to read aloud accurately a graded list of 63 pronounceable printed non-words. Each child is given 45 seconds to read as many words and non-words as possible. The total raw score of this subtest ranges from 0 to 63. The raw score from each subtest is then standardised based on the age of the participants, and the final score is the sum of the standardised scores from both subtests. A lower overall score indicates greater difficulties with reading. Both subtests have demonstrated excellent test-retest reliability of above 0.90 (Torgesen et al., 1999) and a strong correlation (0.63 , $p < 0.05$) with teacher-reported school performance (Trzesniewski et al., 2006). TOWRE composite scores were used in our analyses, obtained by

standardising and summing the sub-test scores. TOWRE composite scores were also used in other studies due to the high correlation between the subtests ($r = 0.82$) (Harlaar, Dale, & Plomin, 2007); $r = 0.78$ in the present study). The TOWRE was only administered in the UK-London subgroup. The subgroup with both RDQ and TOWRE data was older than the subgroup without TOWRE data ($p < 0.01$). There were no differences in gender, IQ or RDQ between the two subgroups.

2.3.3 Analyses

2.3.3.1 Multivariate modeling on sibling data

We are interested in the extent to which the traits of ADHD, RDQ and IQ share aetiological influences. The power to ascertain this comes from sibling data, because we know the amount of additive genetic (A), shared environmental (C) and child-specific environmental (E) influences shared between members of a sibling pair. Twin modelling is a common application of such quantitative genetic methodology, where comparisons between monozygotic (MZ) and dizygotic (DZ) twin pairs uses known amount of A, C and E sharing between members of twin pairs to decompose the variance in traits into these influences as aetiological factors (see section 1.3.1.1). Familial modelling, using sibling pairs, is an extension of this methodology. As sibling pairs all share 50% of their alleles, unlike MZ vs DZ pairs that share 100 vs 50% respectively, we can only combine A and C into familial (F) influences. Thus, under the assumption that siblings reared together share approximately 50% of their alleles, and 100% of their C influences, sibling correlations on a trait allow us to decompose the variance between traits into F and E influences, where E also subsumes possible measurement error. As with DZ twin data, the covariance between members of a sibling pair is considered to arise from A and C influences. Without twin data, it is impossible to know the exact A:C ratio, and A and C are subsumed together in the F parameter. If the covariance between members of a

sibling pair is entirely due to A, the sibling covariance (like DZ covariance) will be exactly half the actual F. If, on the other hand, the covariance between members of a sibling pair is entirely due to C, the sibling covariance (like DZ covariance) will be exactly equal to F. Without a comparison group, the exact constituent of F is unknown. Therefore, F could be specified as equal to, or half, the sibling covariance (or somewhere in between). Under the assumption that ADHD is broadly genetic (~80%) (Burt, 2009; Faraone & Biederman, 2005), we chose to specify F as half the sibling covariance. This conservative estimate prevents an overestimation of familiarity; however, as it is a conservative estimate, we here focus on shared F influences, which are not subject to such limitations.

Multivariate familial modelling on sibling data also uses sibling correlations on a trait (e.g. correlations between sibling 1 and sibling 2 for IQ), but also includes information on phenotypic correlations (e.g. correlations between IQ and reading difficulties), and cross-sibling-cross-trait correlations (e.g. correlations between the reading difficulties score of sibling 1 and IQ score for sibling 2). Using the same logic as above, we can decompose the covariance between traits into F and E influences.

The Cholesky (triangular) decomposition describes the extent to which traits share common F influences (Figure. 2-1). The selection variable (ADHD status) is included in all models to correct for the selected nature of the sample, which necessitates ordinal data analysis. As such, 95% confidence intervals are not available. However, the significance of parameters in the main model (Figure. 2-1 & Figure. 2-2) was tested by dropping each parameter in turn, and comparing the χ^2 of the reduced model to that of the full model with a 1-*df* test of freedom at the $p < 0.05$ level. A significant result indicates that the dropped parameter is significant with an α level of 0.05 (Wood et al., 2010b).

2.3.3.2 Familial structural equation models (SEM)

The SEM program Mx (Neale, Boker, Xie, & Maes, 2006a) was used to conduct the genetic analyses and to estimate phenotypic correlations. To account for the selected nature of the sample, the selection variable (ADHD status) was included in all models, with its prevalence and familiarity parameters fixed (Rijsdijk et al., 2005). The Mx program cannot include both ordinal and continuous data in the same analysis, and, as the selection variable is ordinal, the age- and sex-regressed residual scores of the cognitive variables were ordinalised into five equal size categories. Regression analyses were done in Stata version 10.0 (Stata Corporation, College Station, TX). The cluster command was used to cluster by family, to account for the non-independence of the sibling sample. Ordinal data analysis assumes the combination of ordered categories to reflect measurements of an underlying multivariate normal distribution of traits, with one or more thresholds per liability distribution to distinguish between the ordered categories (Rijsdijk et al., 2005). The threshold for ADHD status was fixed to a z-value of 1.64 to give a population prevalence of 5%, and its parameters fixed to expected population estimates, with the familiarity of ADHD fixed to 80% based on a sibling correlation of 0.40 (Rijsdijk et al., 2005).

2.3.3.3 Phenotypic correlation

Sibling correlations were estimated from a phenotypic correlation model, specified in a Gaussian decomposition to give maximum likelihood phenotypic correlations between the measures and to allow for additional constraints. The first imposed constraint is fixing sibling correlation for ADHD status to 0.40 to correct for ascertainment bias, by means of a method developed and validated in a previous study (Rijsdijk et al., 2005). Additional constraints reflect the assumptions of the familial model: that the phenotypic

correlation across traits is the same across individuals and that cross-trait cross-sibling correlations are independent of sibling order.

2.4 RESULTS

To account for group differences in IQ and reading performance across age, gender and centre group (Tables 2-1 and 2-2), IQ and reading data were regressed for these variables. Centre group differed significantly in age and IQ ($p < 0.01$) but not in gender or reading performance ($p > 0.05$). The residual scores obtained from the regression were then used to derive the phenotypic, familial and child-specific environmental correlations, and the familial parameter estimates (Table 2-3). The correlation between RDQ and TOWRE reading measures was $r = -0.54$ ($p < 0.01$).

2.4.1 Reading difficulties questionnaire (RDQ)

We calculated the sum of F influences underlying the covariance between ADHD and RDQ that are not shared with IQ (path $f_{2,2} \times f_{3,2}$ in Figure 2-1) as a percentage of the total F influences underlying the covariance (i.e. including those shared with IQ; $f_{2,1} \times f_{3,1} + f_{2,2} \times f_{3,2}$). In total; 72% of the shared F between ADHD and RDQ was not shared with IQ.

We calculated the sum of E influences underlying the covariance between ADHD and RDQ that are not shared with IQ in the same manner. By summing F and E influences, we obtain all the aetiological influences accounting for the covariance between phenotypes, which leads us to deduce that 78% of the phenotypic covariation between ADHD and reading difficulties was driven by aetiological influences that were not shared with IQ.

Table 2-1. Means (and standard deviations) for gender, age, IQ and reading difficulties questionnaire (RDQ) in ADHD probands, siblings of ADHD probands and unaffected controls.

	ADHD Probands (n=630)	ADHD siblings			Controls (n=485)	<i>F</i> / χ^2	<i>p</i>
		Affected (n=84)	Subthreshold (n=77)	Unaffected (n=513)			
Male %	88	71	57	47	59	213.09	0.01
Age	11.46 (2.69)	11.06 (3.10)	11.53 (2.74)	11.77 (3.25)	12.11 (2.76)	7.09	0.01
IQ	100.64 (14.74)	99.78 (14.11)	98.13 (14.12)	104.04 (13.86)	107.13 (12.17)	29.32	0.01
RDQ	16.33 (7.55)	15.53 (8.14)	14.95 (7.44)	10.36 (5.99)	9.86 (5.45)	142.64	0.01
Centre groups %							
Netherlands	53	71	49	48	49		
UK- London	27	21	27	28	51		
UK- Southampton	8	2	18	11	0	163.38	0.01
Spain	12	6	6	13	0		

Table 2-2. Means and (standard deviation) of gender, age, IQ and TOWRE scores in ADHD probands, siblings of ADHD probands and unaffected controls.

	ADHD Probands (n=630)	ADHD siblings			Controls (n=485)	<i>F</i> / χ^2	<i>p</i>
		Affected (n=84)	Subthreshold (n=77)	Unaffected (n=513)			
Male %	89	55	60	45	77	109.60	0.01
Age	12.19 (2.58)	10.29 (2.77)	11.81 (3.24)	11.89 (2.97)	12.58 (2.33)	4.64	0.01
IQ	99.06 (14.66)	98.13 (15.66)	93.75 (14.46)	101.82 (13.39)	108.30 (13.78)	17.44	0.01
TOWRE	92.46 (16.73)	92.81 (16.92)	93.18 (15.94)	98.94 (14.94)	100.52 (14.63)	8.77	0.01
Centre groups %							
Netherlands	0	0	0	0	0		
UK- London	77	90	60	73	100		
UK- Southampton	23	10	40	27	0	85.18	0.01
Spain	0	0	0	0	0		

Table 2-3. Maximum likelihood phenotypic (r), familial (rF) and child-specific environmental (rE) correlations across ADHD, IQ, reading difficulties (RD) and TOWRE scores.

	IQ	RDQ	TOWRE
<i>Phenotypic correlations (r)</i>			
ADHD	-0.17**	0.25**	-0.22**
IQ	1	-0.34**	0.43**
<i>Familial correlations (rF)</i>			
ADHD	-0.29**	0.38**	-0.35*
IQ	1	-0.36**	0.54**
<i>Child - specific environmental correlations (rE)</i>			
ADHD	-0.09*	0.19**	-0.13*
IQ	1	-0.35**	0.35**

** p<0.001

* p< 0.01

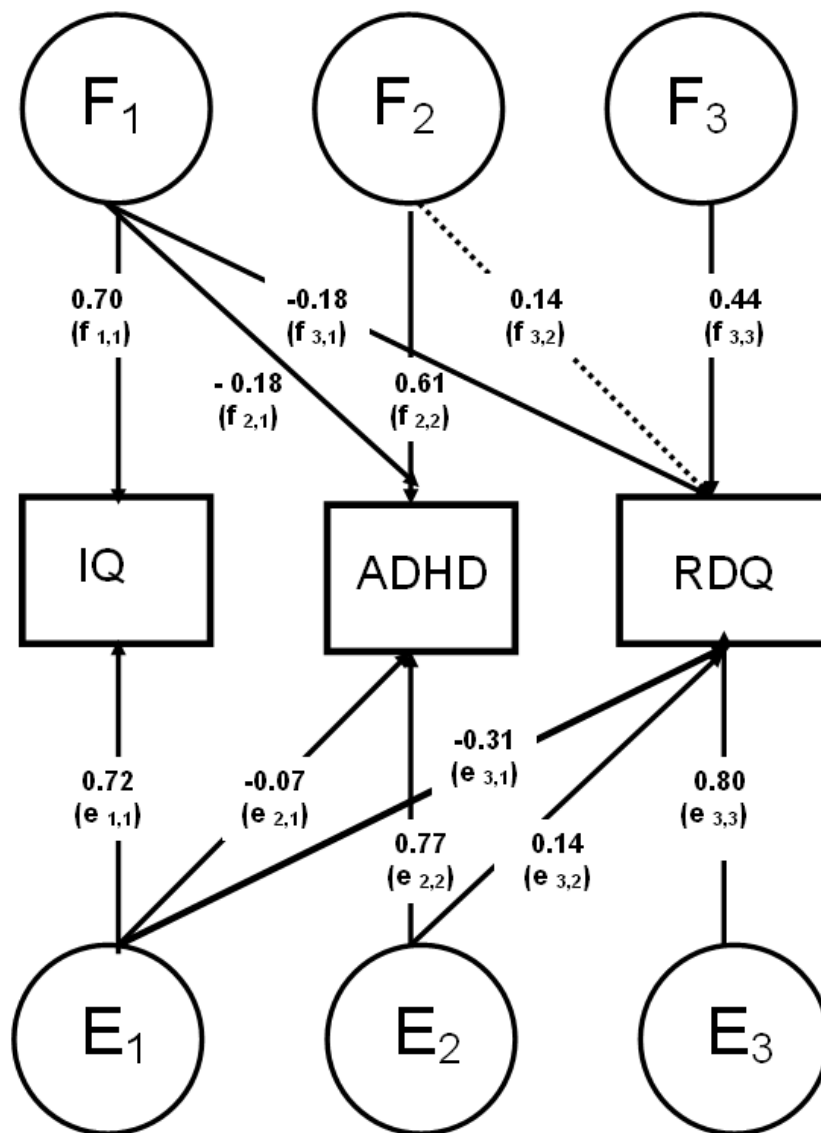

Figure 2-1 Parameters F1-F3 and parameters E1-E3 are estimates from Cholesky models estimating the familial and child-specific environmental factors across IQ, ADHD and Reading Difficulties Questionnaire (RDQ).

Significant paths ($p < 0.05$) are indicated as solid lines and non-significant paths ($p \geq 0.05$) are indicated as dotted lines.

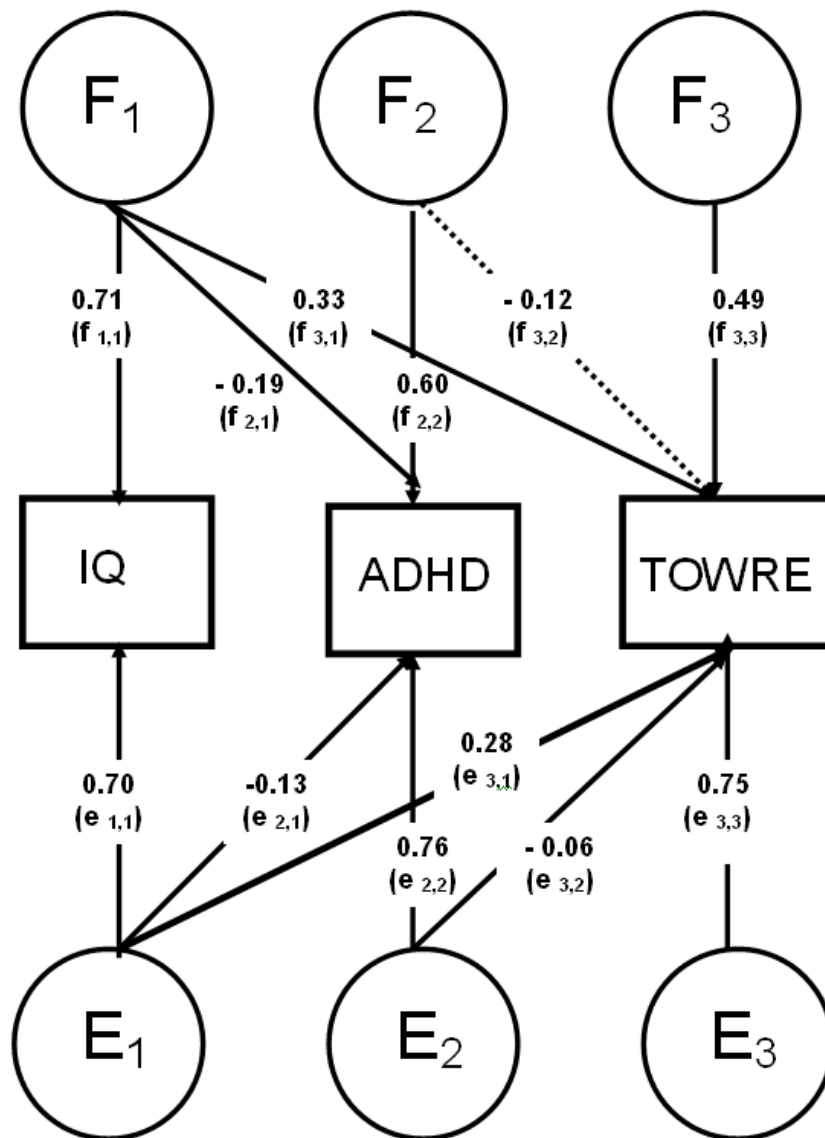

Figure 2-2. Parameters F1-F3 and parameters E1-E3 are estimates from Cholesky models estimating the familial and child-specific environmental factors across IQ, ADHD and Test of Word Reading Efficiency (TOWRE).

Significant paths ($p < 0.05$) are indicated as solid lines and non-significant paths ($p \geq 0.05$) are indicated as dotted lines.

2. 5 DISCUSSION

Our findings from both rating scale and objective measures of reading indicate that over half (53 to 72%) of the overlapping familial influences between ADHD and reading difficulties were not shared with IQ. This finding is consistent with recent evidence from a population-based twin study that focused on the association between parent ratings of reading difficulties and continuous ADHD symptom scores (Paloyelis et al., 2010). This was the first study to examine the relationship between ADHD, reading difficulties and IQ in a sample selected for ADHD-C. The generalisability of the findings from a population sample to a clinical sample with ADHD-CT is consistent with pre-existing evidence suggesting that both ADHD and RD represent the extreme and impairing tail of continuously distributed traits of ADHD symptoms and reading ability scores (Chen et al., 2008; Harlaar et al., 2005; Levy et al., 1997; Shaywitz, Escobar, Shaywitz, Fletcher, & Makuch, 1992). Overall, our results suggest that there are both unique processes that contribute to the co-occurrence between ADHD and reading difficulties and common processes that are shared with general cognitive abilities.

Between 48% and 62% of the phenotypic overlap between ADHD and reading difficulties, measured by the RDQ and the TOWRE, respectively, was due to shared familial influences. This is consistent with previous twin studies of both ADHD and RD that showed the comorbidity between these two disorders are in part (50-75%) due to common genetic influences (Gilger et al., 1992; Light et al., 1995; Paloyelis et al., 2010; Stevenson et al., 1993). Findings from this study supported the common genetic aetiology hypothesis for the co-occurrence between ADHD and reading difficulties. Alternative explanations such as sampling artefacts (Berkson, 1946), assortative mating for ADHD and RD (Faraone et al., 1993), or a causal relation between ADHD and RD (Pennington, Grossier, & Welsh, 1993b) would also be consistent with the shared genes account.

Although these alternative hypotheses were not tested in the present study due to insufficient power with ordinal data analysis, previous studies in ADHD and RD have shown that the association between ADHD and RD was not due to sampling or measurement artefacts as the findings were replicated in population-based samples using both objective (Willcutt et al., 2000b) and subjective (Martin et al., 2006; Paloyelis et al., 2010) measures of reading. Moreover, assortative mating has not been consistently observed (Doyle, Faraone, DuPre & Biederman, 2001) and significant bivariate heritability between ADHD and RD from twin studies provided evidence against the assortative mating hypothesis (Gilger et al., 1992; Light et al., 1995; Paloyelis et al., 2010; Stevenson et al., 1993; Willcutt et al., 2000b; Willcutt et al., 2007), given that assortative mating decreases estimates of shared genetic influences (Willcutt et al., 2000b).

The phenocopy hypothesis (Pennington et al., 1993b) argues that the co-occurrence between ADHD and RD is a result of the primary disorder causing manifestation of deficits associated with the secondary disorder, in the absence of aetiological influences associated with the secondary disorder. This hypothesis was not supported for ADHD and RD by neuropsychological studies, in which individuals with comorbid ADHD and RD exhibited cognitive deficits that are associated with both ADHD and RD (Willcutt et al., 2007). The present study was the first using a selected sample with ADHD to show shared familial association between ADHD and reading difficulties, and further provided evidence against the phenocopy hypothesis. There is growing evidence including the present study, supporting the existence of common sets of genes which explain the comorbidity between ADHD and reading difficulties (Gilger et al., 1992; Light et al., 1995; Paloyelis et al., 2010; Stevenson et al., 1993; Willcutt et al., 2000b; Willcutt et al., 2007). This has potential implications for future clinical intervention to identify treatments that target both ADHD symptoms and reading difficulties, although the presence of shared

aetiological influences could be explained by pleiotropic effects (the multiple phenotypic effects of genes) impacting on multiple neurobiological processes, which could be targeted independently of each other. Further work is needed to identify the neurobiological processes that mediate these familial effects on ADHD and RD.

The two reading measures we used were highly correlated with one another and yielded similar phenotypic correlations with ADHD. Furthermore, the results obtained with either the RDQ or the TOWRE measures in the London subgroup were comparable, indicating that around 53% to 72% of familial influences shared between ADHD and reading ability/disability were independent of IQ. It should be noted, however, that the RDQ is a general measure of a child's overall reading difficulties, while the TOWRE measures specific processes in reading such as reading fluency, word recognition and phonemic awareness. Measures that tap specific aspects of the reading process will be required in future research to fully disentangle the aetiological basis for the covariation between ADHD and reading difficulties.

Whereas a sibling design is a powerful tool for studying shared familial effects in samples with clinically-ascertained probands, a limitation is that genetic effects cannot be separated from shared environmental effects. However, previous studies indicate a limited contribution for shared environmental factors in ADHD (Burt, 2009), suggesting that the familial influences that underlie ADHD and reading difficulties in this study reflect mainly genetic effects. Another limitation in the present study is that, due to computational intensity of ordinal data, confidence intervals could not be obtained. However, we did test the significance of each at an alpha level of 0.05.

Overall, in a sibling-pair sample selected for ADHD combined subtype and controls, a large proportion (53-72%) of the overlapping familial influences on ADHD and reading

difficulties are not shared with IQ. The generalisability of the current findings to other populations needs to be examined in future research. Recent studies have explored the relationship between ADHD and reading difficulties beyond a behavioural level, by using cognitive endophenotypes to further understand the genetic aetiology and architecture on a neurocognitive level (McGrath et al., 2010; Willcutt et al., 2010). The results from these multivariate twin studies selected for RD suggest that the comorbidity between ADHD and RD is driven by common genetic influences also shared with slow processing speed. Future studies should replicate these findings in the general population and explore other cognitive endophenotypes associated with ADHD such as reaction time and reaction time variability. Neurocognitive measures that are associated and share common genetic influences with ADHD and RD maybe be useful for a more in depth understanding of the comorbidity between the two disorders on a molecular level.

CHAPTER 3 – SHARED COGNITIVE IMPAIRMENTS AND AETIOLOGY IN INATTENTION AND READING

3.1 ABSTRACT

Twin studies indicate that the frequent co-occurrence of attention-deficit/hyperactivity disorder (ADHD) symptoms and reading difficulties (RD) is largely due to shared genetic influences. Both disorders are associated with multiple cognitive impairments, but it remains unclear which cognitive impairments share the aetiological pathway, underlying the co-occurrence of the symptoms. We address this question using a sample of twins aged 7-10 and a range of cognitive measures previously associated with ADHD symptoms or RD. We performed multivariate structural equation modelling analyses on parent and teacher ratings on the ADHD symptom domains of inattention and hyperactivity, parent ratings on RD, and cognitive data on response inhibition (commission errors, CE), reaction time variability (RTV), verbal short-term memory (STM), working memory (WM) and choice impulsivity, from a population sample of 1312 twins aged 7– 10 years. Three cognitive processes showed significant phenotypic and genetic associations with both inattention symptoms and RD: RTV, verbal WM and STM. While STM captured only 11% of the shared genetic risk between inattention and RD, the estimates increased somewhat for WM (21%) and RTV (28%); yet most of the genetic sharing between inattention and RD remained unaccounted for in each case. While response inhibition and choice impulsivity did not emerge as important cognitive processes underlying the co-occurrence between ADHD symptoms and RD, RTV and verbal memory processes separately showed significant phenotypic and genetic associations with both inattention symptoms and RD. Future studies employing longitudinal designs will be required to investigate the developmental pathways and direction of causality further.

3.2 INTRODUCTION

Attention-deficit/hyperactivity disorder (ADHD) and reading disability are strongly heritable, complex neurodevelopmental disorders that frequently co-occur (Cheung et al., 2012; McGrath et al., 2011; Paloyelis et al., 2010; Willcutt et al., 2010). Sibling and twin studies indicate that the phenotypic association between ADHD and reading difficulties (RD) is largely attributed to shared familial/genetic influences (Cheung et al., 2012; Martin et al., 2006; Paloyelis et al., 2010; Willcutt et al., 2007). Of the two ADHD symptom domains of hyperactivity-impulsivity and inattentiveness, RD shows stronger phenotypic and genetic associations specifically with inattention symptoms, compared to hyperactivity-impulsivity symptoms (Greven et al., 2011b; Martin et al., 2006; Paloyelis et al., 2010; Willcutt et al., 2007).

Linking the familial risk factors in ADHD to cognitive impairments, we obtained evidence in sibling-pair analyses for two familial cognitive impairment factors in ADHD (Kuntsi et al., 2010). The first and larger familial factor captured familial influences on RT variability (RTV), and is separated from the second familial factor, which captured familial influences on commission errors (CE) and omission errors (OE) on a Go/No-Go task. Applying the same analysis approach to an independent dataset of ADHD and control sibling pairs, with different cognitive and motor tasks, again two familial factors emerged where familial factor loading on ‘intra-individual variability’ was separate from those on working memory (WM) (Frazier-Wood et al., 2012). Overall, the findings from the sibling studies on children and adolescents with ADHD indicate two familial cognitive impairment factors in ADHD, the first capturing slow and high variable responses and the second capturing aspects of executive functioning, both of which largely separate from familial influences shared between ADHD and IQ.

By mapping the aetiological factors underlying ADHD-related cognitive impairments onto those of the two ADHD symptom domains separately using a population sample of twins, we further demonstrated that RTV and CE reflect different genetic relationships to the two ADHD symptom domains (Kuntsi et al., 2013). While RTV showed substantial genetic overlap particularly with inattentiveness, CE showed little genetic overlap with either hyperactivity-impulsivity or inattentiveness.

Similar to ADHD, individuals with RD also show impairments in multiple domains of cognitive functions, including verbal WM, RTV and processing speed (Roodenrys, Koloski, & Grainger, 2001; Shanahan et al., 2006; Swanson, Xinhua, & Jerman, 2009; Tannock, Martinussen, & Frijters, 2000; Willcutt et al., 2005a; Willcutt et al., 2001; Willcutt et al., 2005b). Findings on response inhibition have, however, been inconsistent (Willcutt et al., 2008b). A sibling study indicated significant shared familial influences on RD with executive functioning and motor vulnerabilities (Rommelse et al., 2009), and a twin study further indicated shared genetic influences on RD with verbal short-term memory (STM) and WM (van Leeuwen, van den Berg, Peper, Hulshoff Pol, & Boomsma, 2009).

Only one study to date has investigated the aetiological sharing between ADHD symptoms, RD and specific cognitive processes (Willcutt et al., 2010), which examined a population sample of 457 twin pairs, aged 8-18, from the Colorado Learning Disabilities Research Centre study. Genetic factors underlying slow processing speed (measured as MRT in symbol search and picture identification tasks) captured a substantial proportion of shared genetic risks between ADHD symptoms and RD, whereas a significant proportion of genetic influences on inhibition or WM were independent of the genetic

covariance between reading and inattention symptoms (Willcutt et al., 2010). These findings require replication and extension into further cognitive measures.

Using multivariate model-fitting analyses on a large population twin sample, with a tightly defined age range (7-10 years), this study aims to investigate which cognitive impairments previously linked to either ADHD or RD, or both (RTV, response inhibition, verbal STM and WM, and choice impulsivity (Paloyelis et al., 2010)), independent of IQ effects, underlie the co-occurring symptoms. Specifically, we address three key questions: i) Which cognitive impairments are associated with both ADHD symptoms and RD? ii) To what extent do these cognitive measures (the identified cognitive variables, RD, and ADHD symptoms) share genetic influences? iii) To what extent does a shared cognitive impairment capture the shared genetic risk between ADHD symptoms and RD?

3.3 METHODS

3.3.1 Sample and Procedure

Participants are members of the Study of Activity and Impulsivity Levels in children (SAIL), a general population sample of twins aged between 7 and 10 years. They were recruited from the Twins Early Development Study (TEDS; (Trouton, Spinath, & Plomin, 2002), a birth cohort study in which parents of all twins born in England and Wales during 1994–1996 were invited to enroll. TEDS families were invited to take part if they fulfilled SAIL project criteria, including White European ethnic origin (to reduce population heterogeneity for molecular genetic studies); no extreme pregnancy or perinatal difficulties, specific medical syndromes, chromosomal anomalies or epilepsy; and not on stimulant or other neuropsychiatric medications (Kuntsi, Neale, Chen, Faraone, & Asherson, 2006a).

Of the 1,230 suitable families contacted, 672 families (55%) agreed to participate. Thirty-two children were subsequently excluded due to: IQ < 70, epilepsy, autism, obsessive-compulsive or other neurodevelopmental disorder, illness during testing or placement on stimulant medication for ADHD. The final sample consisted of 1312 individuals: 257 monozygotic (MZ) twin pairs, 181 same-sex dizygotic (DZ) and 206 opposite-sex DZ twin pairs, as well as 24 singletons coming from pairs with one of the twins excluded. Data for the 24 singleton twins were also used in the structural equation modeling (Neale, Roysamb, & Jacobson, 2006b).

The families visited the research centre for the assessments. Two testers assessed the twins simultaneously in separate testing rooms. The tasks were administered in a fixed order as part of a more extensive test session, which in total (including breaks) lasted approximately 2.5 hours. The mean age of the sample was 8.83 (SD = 0.67), and half of the sample were female (N = 663, 50.5%). Children's IQs ranged from 70 to 158 (M = 109.34, SD = 14.72). Parents of all participants gave informed consent following procedures approved by the Institute of Psychiatry Ethical Committee.

3.3.2 Measures

ADHD Ratings. Parent and teachers were asked to complete the Long Versions of Conners' Parent Rating Scale (Conners et al., 1998a) and the Long Version of Conners' Teacher Rating Scales (Conners et al., 1998b). ADHD inattention and hyperactivity-impulsivity symptoms were obtained using the summed parent and teacher ratings on the 9-item inattentive DSM-IV subscales and the 9-item hyperactivity-impulsivity DSM-IV subscales, respectively. Teacher ratings were missing for 151 individuals and parent ratings for two individuals.

Reading difficulties. Reading Difficulties Questionnaire (RDQ) is a subscale of the Colorado Learning Difficulties Questionnaire (Willcutt et al., 2011b). This six-item parent rating scale is part of an instrument screening for learning disorders. On a scale that ranges from 1 (never/not at all) to 5 (always/a great deal), parents reported the extent of their child's difficulties with spelling, learning letter names, sounding words out, and to what extent their child reads slowly, below expectancy level or has required extra help at school. The total score ranges from 5 to 30, with higher scores indicating greater difficulties with reading.

IQ. The vocabulary, similarities, picture completion and block design subtests from the Wechsler Intelligence Scales for Children WISC-III (Wechsler, 1991) were used to obtain an estimate of the child's IQ (prorated following procedures described by (Sattler, 1992)). The digit span subtest from the WISC-III was administered to obtain digit span forward (DSF) and digit span backward (DSB) (Wechsler, 1991), which measure verbal STM and WM, respectively.

The Go/No-Go task (GNG) (Borger & van der Meere, 2000; Kuntsi, Andreou, Ma, Borger, & van der Meere, 2005a). On each trial of the GNG task, one of two possible stimuli appeared for 300 ms in the middle of the computer screen. The participant was instructed to respond only to the 'go' stimuli and to react as quickly as possible, but to maintain a high level of accuracy. The proportion of 'go' stimuli to 'no-go' stimuli was 4:1. The participants performed the task under three conditions (slow, fast and incentive), matched for length of time on task. Herein we present data from the slow condition, which had an inter-stimulus interval (ISI) of 8 s and consisting of 72 trials, and the fast condition, with an inter-stimulus interval (ISI) of 1 second and consisting of 462 trials.

The order of presentation of the slow and fast conditions varied randomly across participants. We focus here on two variables obtained from the task: CE and RTV.

The Fast Task (Andreou et al., 2007; Kuntsi et al., 2006b). The baseline condition of the Fast Task, with a foreperiod of 8 s and consisting of 72 trials, followed a standard warned four-choice RT task. A warning signal (four empty circles, arranged horizontally) first appeared on the screen. At the end of the foreperiod (presentation interval for the warning signal), the circle designated as the target signal for that trial was filled (coloured) in. The participant was asked to make a compatible choice by pressing the response key that directly corresponded in position to the location of the target stimulus. Following a response, the stimuli disappeared from the screen and a fixed inter-trial interval of 2.5 s followed. Speed and accuracy were emphasised equally. If the child did not respond within 10 s, the trial terminated. A comparison condition with a fast event rate (1 second) and incentives followed the baseline condition (Andreou et al., 2007). Herein we focus on RTV, obtained from the baseline condition.

To limit the total number of variables and to create psychometrically robust variables that would enable direct comparisons to our previous findings using the same tasks in a clinically diagnosed sample (Kuntsi et al., 2010), the summed unstandardized scores of RTV were obtained across the baseline conditions of the GNG and the Fast Tasks. A composite measure of CE was obtained by summing the raw CE scores from both the baseline (slow) and the fast conditions of the GNG task.

The Maudsley Index of Childhood Delay Aversion (Kuntsi et al., 2006a; Paloyelis, Asherson, & Kuntsi, 2009). Two conditions, each with 20 trials, were administered. In each trial, the child had a choice between a smaller-immediate reward (one point involving a 2-second

Chapter 3 – Shared cognitive impairments and aetiology in inattention and reading pre-reward delay) and a larger-delayed reward (two points involving a 30-second pre-reward delay). In the no post-reward delay condition, choosing the small reward led immediately to the next trial, reducing the overall length of the condition. In the post-reward delay condition, choosing the small reward led to a delay period of 30 seconds, and choosing the large reward led to a delay period of 2 seconds before the next trial. The order of the two conditions was randomly chosen for each twin. Choice impulsivity (CI) was calculated here as the number of times the smaller-immediate reward was selected in the no post-reward delay condition, controlling for total number of trials attempted.

3.3.3 Statistical analyses

3.3.3.1 Structural equation models

The structural equation modeling program Mx was used (Neale et al., 2006b). Models were fitted to IQ-, age- and sex-regressed unstandardised residual summed scores, which were transformed to minimize skewness using the optimised minimal skew command in Stata version 10.0 (Stata Corporation, College Station, TX). All estimates are provided with 95% confidence intervals (the inclusion of zero indicates non-significance). The relative goodness of fit of the competing hierarchical (or nested) models was assessed using a likelihood ratio test.

3.3.3.2 Univariate genetic models

Univariate modeling was used to inform the choice of parameters for the multivariate models and to test for sex effects. Using twin correlations, the phenotypic variances of the measures were decomposed into the parameters A, C/D or E (section 1.3.1). As C and D cannot be modeled simultaneously in the classical twin model (Rijsdijk & Sham, 2002), the choice of whether to fit C or D was based on twin correlations. As the DZ correlations were less than half of MZ correlations for all variables (Table 3-1), we fitted ADE models

only (Appendix A).

3.3.3.3 Sex effects

Within the univariate modeling, the presence of sex-specific influences on the phenotypes was tested. Models were fitted to test i) whether the magnitude of aetiological (A, C/D and E) influences underlying a trait are significantly different for males and females (quantitative sex differences); ii) whether the aetiological factors influencing males differ to those influencing females, regardless of the magnitude differences (qualitative sex differences); and iii) whether there are phenotypic variance differences between males and females (scalar sex differences). To test for these sex differences, a series of nested models with different constraints were employed.

Qualitative sex differences are tested in models where, in turn, the genetic correlations between males and females in DZ opposite-sex (DZOS) pairs are fixed to 0.5 and the shared environmental correlations are fixed to 1.00 or D fixed to 0.25. Significant qualitative sex differences are indicated if the genetic correlations between DZOS pairs are less than 0.5, and significant qualitative environmental sex differences are indicated if the shared environmental correlations between DZOS pairs are less than 1.00.

Quantitative differences model is fitted where the variances are equated across males and females, but the standardised A, D and E estimates are free to differ. This model is compared to the sex differences model, which allows for both scalar (variance inequality) and quantitative differences between males and females, with a 1-df test of significance. Then the scalar model is fitted where the standardised A, D and E parameters are equated across males and females, but the scaling factor is free to differ across males and females, which allows the standard deviations to differ across gender. The fit of the scalar

model is compared to the sex differences model with a 2-df test of significance.

Scalar differences for reading difficulties and inattention were observed. Scalar sex differences are found where only unstandardised A, C/D and E estimates differ (but standardised estimates are the same), due to variance differences in the trait distribution between males and females. Therefore, in the multivariate modeling, male phenotypic variances for these traits were pre- and post- multiplied by a scaling factor. Given the scalar differences between the sexes, means and standard deviations are broken down into sex- and zygosity- specific groups (Table 3-1). No significant qualitative or quantitative differences in variance components between the sexes were observed on any variables ($p > 0.05$), and the MZ and DZ correlations for each variable are presented for males and females separately (Appendix B).

3.3.3.4 Parameter selection for the multivariate models

In the univariate analyses, an AE model provided the best fit for DSF, DSB and RTV, while ADE/DE models (with scalar sex differences) fitted best for inattention and RD (as we would predict from the MZ : DZ ratios of cross-twin correlations for these traits; Table 3-1). Due to difficulties with distinguishing between A and D effects in the classic twin design with insufficient sample size, we model broad-sense genetic (G) influences that combines both A and D effects. As there were no qualitative or quantitative sex differences in the univariate analyses beyond scalar differences, only scalar differences between males and females were allowed in the multivariate models.

3.3.3.5 Multivariate genetic models

Multivariate genetic analyses use the power given by the MZ:DZ ratio of cross-twin cross-trait correlations to decompose the covariation between traits into G and E influences

(Rijsdijk & Sham, 2002). **i) Correlated factor model:** Diagonal matrices are used to estimate how much of the variances on each trait are due to genetic (broad sense heritability, X) and non-shared environmental factors (Y). Correlation matrices are specified to estimate the extent to which the genetic and environmental factors overlap (i.e. the genetic (r_g) and environmental (r_e) correlations). The total covariance model is then given by $X*r_g*X' + Y*r_e*Y'$. **ii) Cholesky decomposition model:** In the Cholesky, a triangular decomposition is used to decompose the variance in each phenotype and covariance between the phenotypes into broad sense genetic (G1-G3; Figures 1-3) and unique environmental (E1-E3) influences. Since Cholesky decompositions require an a priori justification of variable order where they contain more than three variables (based on, for example, temporality within longitudinal data), and our data were cross-sectional, we ran three separate Cholesky models to determine the extent to which the covariation between ADHD symptoms and RD is independent of cognitive measures of RTV, verbal STM and WM. RTV/STM/WM (i.e. the objectively measured cognitive process) was entered as the first variable in the Cholesky model, with the rating scale data (RD and inattention)

Table 3-1. Twin correlations^a (with 95% confidence intervals), means and standard deviations^b across inattention (IA), reading difficulties (RD), reaction time variability (RTV), digit span forward (DSF) and digit span backward (DSB)

	IA		RD		RTV		DSF		DSB	
	MZ	DZ	MZ	DZ	MZ	DZ	MZ	DZ	MZ	DZ
IA	.56 (.47, .68)	.08 (-.02, .19)								
RD	.36 (.24, .47)	.07 (-.03, .17)	.67 (.60, .74)	.16 (.06, .29)						
RTV	.23 (.10, .34)	-.03 (-.13, .08)	.18 (.06, .30)	.06 (-.04, .17)	.44 (.33, .54)	.21 (.11, .31)				
DSF	-.15 (-.28, -.03)	-.02 (-.09, .12)	-.15 (-.27, -.03)	-.07 (-.17, .04)	-.11 (-.23, .02)	.01 (-.10, .11)	.59 (.50, .66)	.28 (.18, .37)		
DSB	-.02 (-.15, .11)	.08 (-.02, .18)	-.21 (-.33, -.10)	-.02 (-.12, .08)	-.10 (-.22, .02)	.04 (-.07, .14)	.37 (.26, .47)	.10 (.00, .20)	.29 (.18, .40)	.11 (.01, .21)
Male	12.70 (8.95)	7.79 (6.51)	10.79 (6.33)	11.47 (6.66)	619.06 (350.81)	631.01 (376.52)	7.74 (1.80)	7.43 (1.58)	4.36 (1.42)	4.23 (1.30)
Female	14.25 (11.14)	9.06 (7.88)	9.90 (4.75)	9.82 (5.06)	629.94 (354.15)	628.04 (359.12)	7.74 (1.60)	8.05 (1.72)	4.52 (1.46)	4.62 (1.40)

Significant correlations in **bold**, ^a estimated using maximum likelihood estimation, ^b Raw score

3.4 RESULTS

We regressed IQ from all cognitive variables and reading difficulties to ensure that we controlled for any mediating effects of IQ that were not the focus of the present analyses, consistent with our previously adopted approach (Kuntsi et al., 2010). Our previous analyses on the current (Wood et al., 2010a) and a separate (Kuntsi et al., 2010) sample have indicated that the majority of genetic influences shared between ADHD and cognitive variables are independent of those shared with IQ (Wood et al., 2010a; Wood et al., 2011).

3.4.1 Which cognitive impairments are associated with both ADHD symptoms and RD?

RTV, DSF and DSB were significantly associated with both ADHD inattention symptoms and RD (Table 3-2). CE and choice impulsivity (CI) were not associated with RD, and only RTV and CE showed significant correlations with hyperactivity-impulsivity. Therefore, we only included RTV, DSF, DSB, inattention and RD in further genetic analyses.

3.4.2 To what extent do inattention, RD, RTV, verbal STM and WM share genetic /unique environmental influences?

Genetic factors accounted for around 60%, 30% and 40% of the variances on DSF, DSB and RTV, respectively (Table 3-3). All cognitive variables showed significant genetic correlations (r_g) with inattention symptoms and RD. The unique environmental correlations (which also includes measuring error) (r_e) were not significant between any cognitive variables and RD (all $r_e < 0.05$). Inattention showed significant r_e only with RTV but not with DSF or DSB. There was substantial genetic overlap between DSB and DSF

($r_g = 0.63$), but the genetic overlap between DSB and RTV was not significant (indicated by confidence intervals overlapping zero).

3.4.3 To what extent does a shared cognitive impairment capture the shared genetic risk between ADHD symptoms and RD?

Using the Cholesky decomposition, we calculated the sum of broad-sense genetic (G) influences underlying the G covariance between inattention and RD that were not shared with RTV ($G_{2,2} \times G_{3,2}$ in Figure 3-1) as a percentage of the total genetic covariance between inattention and RD ($G_{2,1} \times G_{3,1} + G_{2,2} \times G_{3,2}$). This led us to deduce that 72% of the genetic overlap between inattention and RD was driven by shared genetic influences that are independent of those underlying RTV. Using the same method, we found that 89% and 79% of the genetic covariance between inattention and RD was independent of the genetic influences underlying DSF and DSB, respectively (Figure 3-2 and 3-3). Since there was no significant overlap in unique environmental influences between RD and any of the cognitive variables, we did not interpret the E findings from the Cholesky decomposition.

Table 3-2. Phenotypic correlations across inattention (IA), hyperactivity-impulsivity (H-I), reading difficulties (RD), reaction time variability (RTV), comission errors (CE), choice impulsivity (CI), digit span forward (DSF) and digit span backward (DSB).

	IA	H-I	RD	RTV	CE	CI	DSF
H-I	.59*						
RD	.48*	.17*					
RTV	.26*	.16*	.18*				
CE	.13*	.09*	.06	.12*			
CI	.14*	.08	.04	.08*	.06		
DSF	-.11*	-.06	-.15*	-.06	.01	-.06	
DSB	-.15*	-.05	-.18*	-.14*	-.05	-.09*	.29*

* p<0.01

Table 3-3. Standardised parameter estimates (with 95% confidence intervals) from the correlated factor model across digit span forward (DSF), digit span backward (DSB), reaction time variability (RTV), reading difficulties (RD) and inattention (IA).

	DSF	DSB	RTV	RD	IA
Genetic influences					
DSF	0.59 (0.51, 0.66)	0.85 (0.65, 1.04)	*	0.98 (0.64, 1.33)	0.99 (0.28, 1.82)
DSB	0.63 (0.46, 0.80)	0.27 (0.17, 0.36)	0.41 (-0.16, 0.89)	0.97 (0.68, 1.29)	0.59 (0.08, 1.04)
RTV	*	-0.17 (-0.37, 0.05)	0.42 (0.33, 0.51)	0.89 (0.59, 1.20)	0.61 (0.32, 0.87)
RD	-0.24 (-0.36, -0.12)	-0.46 (-0.50, -0.28)	0.32 (0.18, 0.46)	0.63 (0.55, 0.69)	0.67 (0.50, 0.82)
IA	-0.17 (-0.31, -0.03)	-0.24 (-0.44, -0.03)	0.32 (0.18, 0.46)	0.52 (0.46, 0.60)	0.52 (0.40, 0.62)

Unique environmental influences					
DSF	0.41 (0.34, 0.49)	<i>0.15</i> <i>(-0.04, 0.35)</i>	*	0.02 <i>(-0.33, 0.36)</i>	0.01 <i>(-0.82, 0.73)</i>
DSB	0.08 <i>(-0.02, 0.19)</i>	0.73 (0.64, 0.83)	0.59 (0.11, 1.16)	<i>0.03</i> <i>(-0.29, 0.32)</i>	<i>0.41</i> <i>(-0.04, 0.92)</i>
RTV	0.13 <i>(0.02, 0.24)</i>	-0.12 <i>(-0.22, -0.02)</i>	0.58 (0.49, 0.67)	<i>0.11</i> <i>(-0.20, 0.41)</i>	0.39 (0.13, 0.68)
RD	-0.01 <i>(-0.13, 0.12)</i>	-0.01 <i>(-0.12, 0.10)</i>	0.04 <i>(-0.07, 0.15)</i>	0.37 (0.31, 0.45)	0.33 (0.18, 0.50)
IA	-0.02 <i>(-0.13, 0.12)</i>	-0.11 <i>(-0.22, 0.01)</i>	0.18 <i>(0.06, 0.29)</i>	0.34 <i>(0.21, 0.46)</i>	0.48 (0.38, 0.59)

The heritability (g^2) and unique environmental variances (e^2) are indicated as bold along the diagonal. The genetic and unique environmental correlations (and 95% confidence intervals) between pairs of variables are given below the diagonal. The contributions of genetic and unique environmental influences to the phenotypic correlations between variables are given above the diagonal.

* Not interpreted due to a lack of phenotypic association

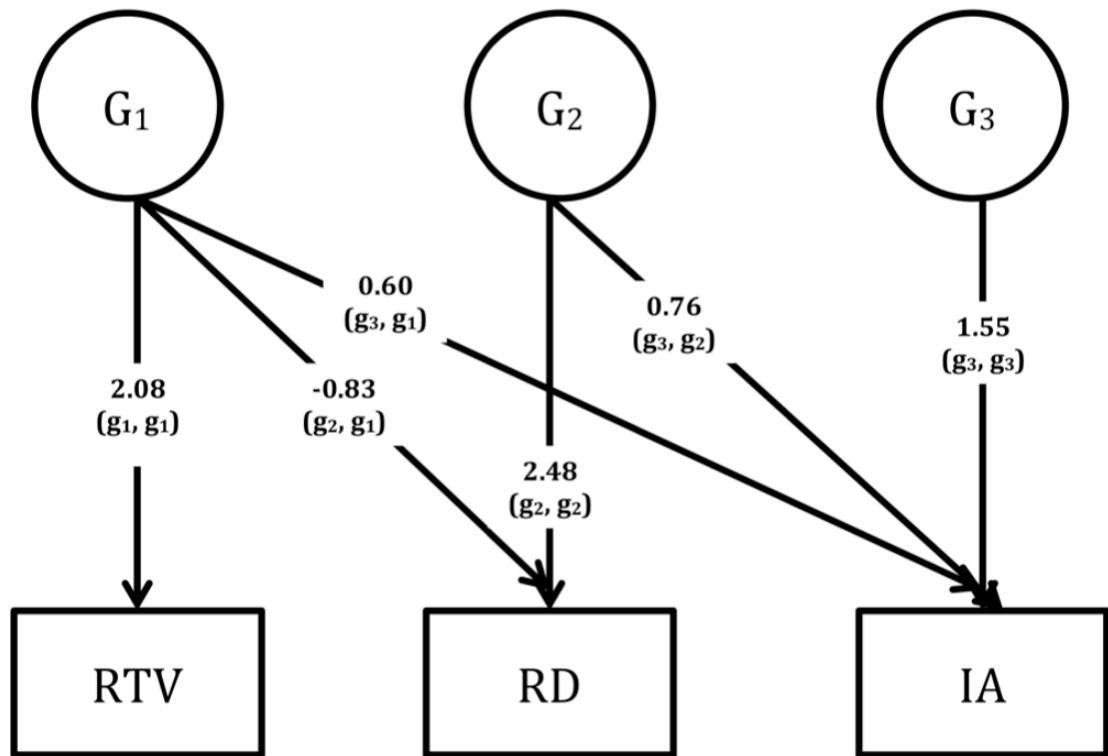

Figure 3-1. Unstandardised parameter estimates (G1-G3) from the Cholesky decomposition across reaction time variability (RTV), reading difficulties (RD) and inattention (IA).

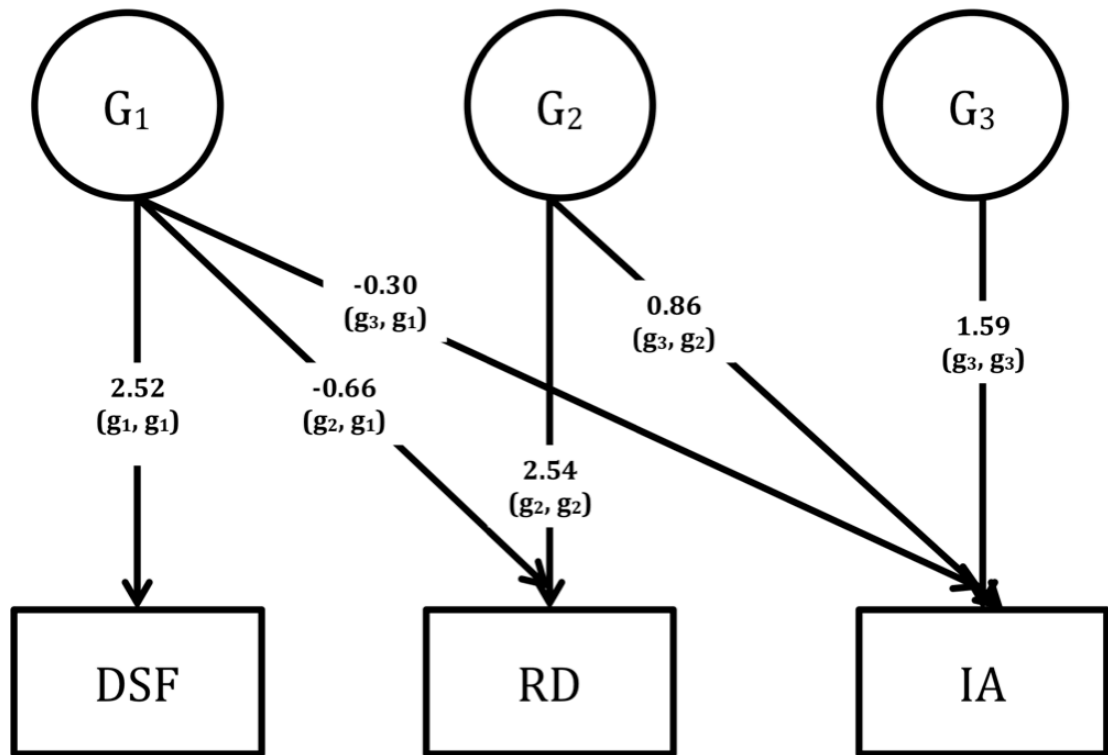

Figure 3-2. Unstandardised parameter estimates (G1-G3) from the Cholesky decomposition across digit span forward (DSF), reading difficulties (RD) and inattention (IA).

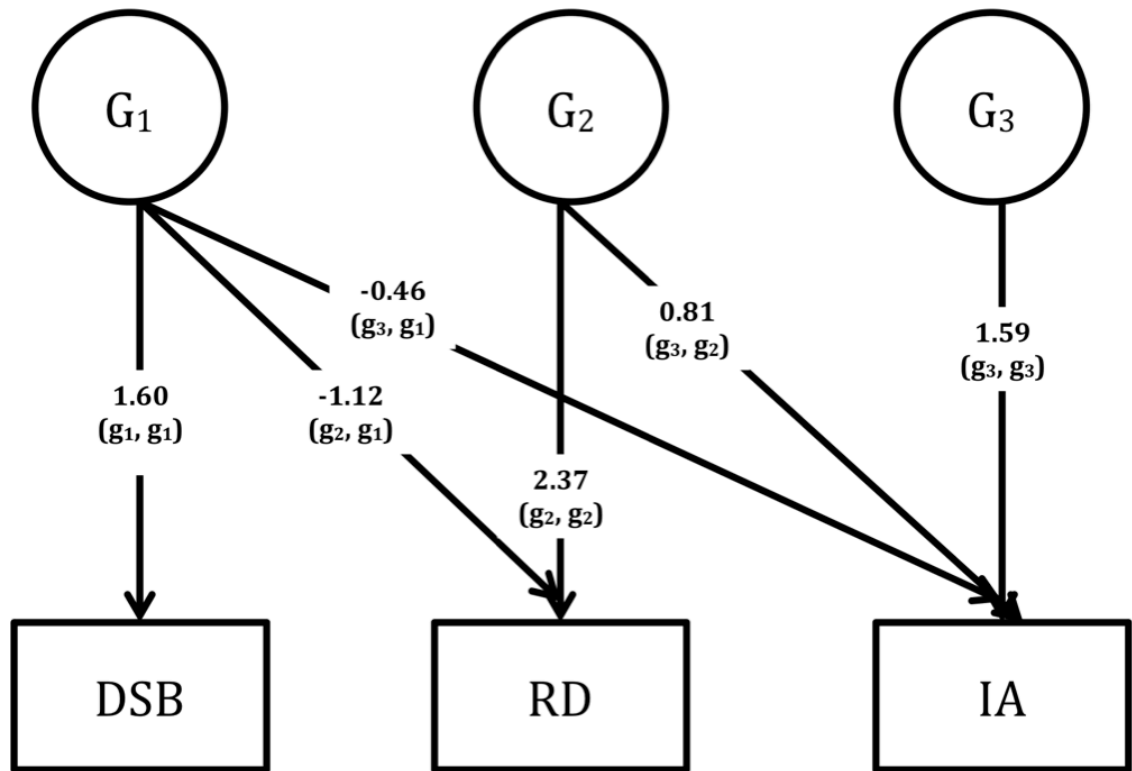

Figure 3-3. Unstandardised parameter estimates (G1-G3) from the Cholesky decomposition across digit span backward (DSB), reading difficulties (RD) and inattention (IA).

3. 5 DISCUSSION

In genetic model fitting analyses on a population sample of twins aged 7-10, we identified three cognitive processes – reaction time variability (RTV), verbal working memory (WM) and verbal short-term memory (STM) – that showed significant phenotypic and genetic associations with both inattention symptoms and reading difficulties (RD). As the genetic influences on RTV separated from those on the memory measures, we further examined, for each cognitive variable in turn, the extent to which it captured the shared genetic risk between inattention and RD. While STM captured only 11% of the shared genetic risk between inattention and RD, the estimates increased somewhat for WM (21%) and RTV (28%); yet most of the genetic sharing between inattention and RD remained unaccounted for in each case.

Response inhibition (CE) and choice impulsivity (stronger preference for smaller-immediate rewards) were not significantly associated with RD, and therefore did not emerge as important cognitive processes that underlie the co-occurrence between ADHD symptoms and RD. Of the two ADHD symptom domains, the associations were largely limited to inattention, with only RTV and CE showing significant, but low correlations with hyperactivity-impulsivity; the association between hyperactivity-impulsivity and RD was also low (0.17), though significant. Overall, the pattern of results further supports the partial aetiological separation of the two ADHD symptom domains (Greven et al., 2011c; McLoughlin et al., 2007).

We observed no phenotypic association between STM and RTV. Despite some evidence of a phenotypic association between WM and RTV ($r_{ph}=0.14$), there was no significant genetic overlap between them. These findings of the genetic risk factors underlying verbal memory processes separating from the genes that increase the susceptibility for

Chapter 3 – Shared cognitive impairments and aetiology in inattention and reading increased RTV are consistent with the aetiological separation between top-down executive functioning in working memory (WM) and measures of intra-individual variability previously reported in a clinical ADHD and control sibling-pair sample (Frazier-Wood et al., 2012).

The strengths of studying twin pairs from the general population lie in the ability to examine the two ADHD symptom domains separately and free from potential referral effects (Rutter et al., 1990). A limitation of the present study is that, despite a large sample of over 1300 twins, we lacked sufficient power to distinguish between additive (A) and dominance (D) genetic effects in the present multivariate analyses on this set of variables where univariate analyses suggested D effects for only two of them (Rietveld, Posthuma, Dolan, & Boomsma, 2003b). We therefore modelled ‘broad sense heritability’ (A+D influences) only. Future replication of these findings in larger samples is crucial.

In this study, we examined the aetiological relationship between ADHD and reading difficulties beyond general cognitive abilities (IQ) (chapter 2) to specific cognitive impairments associated with ADHD. We identified three cognitive measures (RTV, STM and WM) that share significant genetic influences with both inattention and reading difficulties, with RTV capturing the highest proportion of shared genetic influences underlying the phenotypic co-occurrence between inattention and reading difficulties. Future studies should extend the investigation into additional cognitive measures, as well as further objective measures of reading. Longitudinal studies will be essential to investigate the developmental pathways and direction of causality.

PART II

Childhood predictors and cognitive-EEG markers of ADHD outcome:
a follow-up study of ADHD and control sibling pairs

CHAPTER 4 – A NEUROPHYSIOLOGICAL PATHWAY TO DECREASED ATTENTIONAL FLUCTUATION IN ADHD

4.1 ABSTRACT

Cognitive performance in attention deficit hyperactivity disorder (ADHD) is characterised, in part, by frequent fluctuations in response speed, resulting in high reaction time variability (RTV). RTV captures a large proportion of the genetic risk in ADHD but, importantly, is malleable, improving significantly in a fast-paced, rewarded task condition. We aimed to investigate the neurophysiological basis of increased RTV and its improvement in ADHD. Using the temporal precision offered by event-related potentials (ERPs), we examined the neurophysiological pathway from the preparatory state (prestimulus ERP activity) to early and late stages of attentional processing (early- and late-P3), and RTV. Ninety-three participants with ADHD and 174 controls completed the baseline and fast-incentive conditions of a four-choice reaction time task, while EEG was simultaneously recorded. A fast condition with rewards normalised attenuated early-P3 amplitudes and significantly improved RTV in ADHD. Yet, prestimulus activity (ERP activity during the 200ms before target onset) was reduced in the ADHD group. ADHD is associated both with a malleable neurophysiological impairment (early-P3) and an inability to adjust the preparatory state (prestimulus activity) in a changed context. The control group also reduced RTV, but by increasing prestimulus activity, while individuals with ADHD recruited an alternative neurophysiological pathway to improved RTV, mediated by ‘adjusted’ early-P3 (with effects of prestimulus activity removed), reflecting attentional alerting. Although early-P3 amplitude and RTV are developmentally stable markers of ADHD, both show malleability and are potential targets for non-pharmacological interventions.

4.2 INTRODUCTION

Inconsistent performance on reaction time tasks is one of the most prominent features of cognitive performance in ADHD. Frequent fluctuations in response speed result in high reaction time variability (RTV), which is one of the most investigated cognitive performance deficits in ADHD research over the past decade and is thought to reflect lapses in attention (Castellanos et al., 2005; Kuntsi & Klein, 2012). Less well investigated, but potentially clinically more promising, is the observation that individuals with ADHD show a significantly greater-than-expected improvement in RTV under a rewarded task condition (Kuntsi et al., 2012). Identifying the neurophysiological basis of such improvement could inform the development of brain training programs for ADHD that focus on reaching and maintaining an optimal state of alertness.

Inducing an optimal state of alertness is challenging, as the effectiveness of task manipulations likely depends on both individual and task factors, such as the age of participants and the length and nature of the overall test battery. Yet several studies have succeeded in demonstrating an ADHD-sensitive improvement in RTV following the introduction of rewards (with or without an additional manipulation with a faster event rate) (Andreou et al., 2007; Slusarek, Velling, Bunk, & Eggers, 2001; Uebel et al., 2010). While studies that have examined separately the effects of rewards and a faster event rate within the same sample are suggestive of rewards leading to a greater improvement in RTV (Banaschewski et al., 2012; Kuntsi et al., 2012; Uebel et al., 2010), a recent study demonstrated, using genetic model fitting across two large sibling and twin samples, that the underlying aetiology is shared between RTV improvement following rewards and a faster event rate (Kuntsi et al., 2012). This study further indicated that RTV baseline performance (in a slow unrewarded condition) measures

the same aetiological process as captured by the RTV improvement across conditions (difference score from the baseline condition to a fast rewarded condition) (Kuntsi et al., 2012). These findings support theories that emphasise the malleability of the observed high RTV in ADHD, such as those that link ADHD to difficulties regulating arousal (Halperin et al., 2008; Johnson et al., 2007a; O'Connell et al., 2009b; Sergeant, 2005; Van der Meere, 2002). While RTV captures a large proportion of the familial influences underlying ADHD, it largely separates from a second familial cognitive impairment in ADHD that captures executive control processes, such as response inhibition (Kuntsi et al., 2010).

The potential of electroencephalography (EEG) in identifying the neurophysiological process underlying the cognitive impairments in ADHD lies in its ability to identify the temporal sequence of the neuronal processes with millisecond accuracy. Parietal P3 components of the event-related EEG potentials (ERPs), reflecting attentional processes, are attenuated in children and adults with ADHD (Szuromi et al., 2011; Tye et al., 2011). While there is some evidence for normalisation in such P3 components in ADHD following stimulant medication (Overtoom et al., 2009; Pliszka, 2007), limited research has investigated whether they can be altered using non-pharmacological techniques. Initial findings from both children and adults with ADHD using a Go/No-Go (GNG) task revealed greater-than-expected increase in P3 amplitudes from a slow to a faster condition (Wiersema et al., 2006a; Wiersema et al., 2006b). Reward also enhanced P3 amplitudes, but similarly in participants with and without ADHD (Groom et al., 2010).

To investigate the neural basis of cognitive improvement in ADHD using a task with strong phenotypic and genetic association with ADHD and demonstrated ADHD-sensitive improvement across conditions (Andreou et al., 2007; Banaschewski et al.,

2012; Kuntsi et al., 2012; Kuntsi et al., 2009), we focus on a parietal P3 across baseline and fast-incentive conditions of the Fast Task in a large sample of ADHD and control participants. The Fast Task (Kuntsi et al., 2005a) is a four-choice RT task that combines rewards and fast event rate, and specifically rewards a reduction in RTV (unlike GNG tasks that reward inhibition performance).

We aimed, first, to establish using a large follow-up sample, whether ADHD continues to be associated with a greater-than-expected RTV improvement across the task conditions in adolescence and early adulthood. Second, we aimed to investigate whether a similar pattern (greatest impairment in ADHD in the baseline condition and a greater improvement between conditions in ADHD than controls) is observed also for the attentional P3. Third, further using the temporal precision ERPs offers, we aimed to explore the relationship between the measures: the association between P3 and RTV, while also examining the contribution of prestimulus neural activity.

4.3 METHODS

4.3.1 Sample

ADHD and control participants who had taken part in our previous research (Chen et al., 2008; Kuntsi et al., 2010) were invited to take part in this study. ADHD participants were recruited through the International Multicentre ADHD Genetics project. All participants were of European Caucasian descent, had one or more full siblings available for ascertainment, and had a clinical diagnosis of DSM-IV combined subtype ADHD during childhood. Participants in the ADHD group were included if they had ADHD in childhood and met DSM-IV criteria for any ADHD subtype at follow up. Exclusion criteria included IQ<70, autism, epilepsy, general learning difficulties, brain disorders and any genetic or medical disorder associated with externalising behaviours that might

mimic ADHD. The control group was originally recruited from primary (ages 6-11 years) and secondary (ages 12-18 years) schools in the UK, aiming for an age- and sex-match with the clinical sample. The same exclusion criteria were applied as for the clinical sample.

At follow up, seven ADHD participants were excluded from the analyses: two became very drowsy during the task, in two cases there was EEG equipment failure, and in three cases there were less than 20 acceptable segments required for averaging of EEG data. Two control participants were excluded, as they met ADHD criteria based on parent report. P3 and RTV were skewed and transformed using the optimized minimal skew (*lnskew0*) command in Stata version 10.0 (Stata Corporation, College Station, TX). The final follow-up sample consisted of 93 ADHD participants (8 sibling pairs and 77 singletons) and 174 controls (81 sibling pairs and 12 singletons). The two groups did not differ in age or gender, but a significant difference in IQ was observed (Table 4-1).

4.3.2 Procedure

The Fast Task was administered as part of a longer assessment session at the research centre. A 48-hour ADHD medication-free period was required. Face-to-face or telephone clinical interviews were administered to the parent of each ADHD proband shortly before or after the participant's assessment.

4.3.3 Measures

ADHD diagnosis. The Diagnostic Interview for ADHD in Adults (DIVA)(Kooij & Francken, 2007), a semi-structured interview based on the DSM-IV criteria, was conducted with the ADHD proband and the parent separately for current symptoms only, because in all cases a clinical and research diagnosis of combined type ADHD had already been

established (Chen et al., 2008). The Barkley's functional impairment scale (BFIS) (Barkley & Murphy, 2006a), was used to assess functional impairments commonly associated with ADHD in five areas of their everyday life. Each item has a score of 0 (never or rarely), 1 (sometimes), 2 (often) or 3 (very often). Participants were classified as 'affected', if they scored a 'yes' on ≥ 6 items on the DIVA for either inattention or hyperactivity-impulsivity based on parent report, and scored ≥ 2 on two or more areas of impairments on the BFIS, rated by their parent.

IQ. The vocabulary and block design subtests of the Wechsler Abbreviated Scale of Intelligence (WASI) (Wechsler, 1999) were administered to all participants to derive an estimate of IQ.

The Fast Task (Andreou et al., 2007; Kuntsi et al., 2006b). The baseline condition consists of 72 trials, which followed a standard warned four-choice RT task. Four empty circles (warning signals, arranged horizontally) first appeared for 8s, after which one of them (the target) was coloured in. Participants were asked to press the response key that directly corresponded to the position of the target stimulus. Following a response, the stimuli disappeared from the screen and a fixed inter-trial interval of 2.5s followed. Speed and accuracy were emphasised equally. If the participant did not respond within 10s, the trial terminated (Figure 4-1a).

A comparison condition followed, with a shorter foreperiod (1s) and incentives (80 trials). Participants were told to respond quickly one after another to win smiley faces and earn real prizes in the end. The participants won a smiley face for responding faster than their own mean reaction time (MRT) during the baseline condition consecutively for three trials (Figure 4-1b). Due to the longer foreperiod in the baseline condition, the

two conditions were not matched on task length, but were matched on the number of trials. We analysed RTV performance on both the full baseline condition and separately on the length-matched segment (Andreou et al., 2007). However, we did not control for task length in the ERP analyses, as data from the full baseline condition was required to obtain adequate trials for ERP averaging.

4.3.4 EEG recording and analysis

The EEG was recorded from 62 channels DC-coupled recording system (extended 10–20 montage), with a 500Hz sampling-rate, impedances kept under 10k Ω , and the frontal-central electrode (FCz) was the reference electrode. The electro-oculograms (EOGs) were recorded from electrodes above and below the left eye and at the outer canthi.

The EEG data were analysed using Brain Vision Analyzer (2.0) (Brain Products, Germany). After down-sampling the data to 256 Hz, the EEG was re-referenced to the average and filtered offline with a digitally band-pass (0.1 to 30 Hz, 24 dB/oct) Butterworth filters. Ocular artifacts were identified from the data using Independent Component Analysis (ICA, (Jung et al., 2000)). The extracted independent components were manually inspected and ocular artefacts were removed by back-projection of all but those components. Data with other artifacts exceeding $\pm 100\mu\text{V}$ in any channel were rejected, and continuous EEG was segmented into event-related 2s (-200-1800ms) epochs. The P3 analysis was performed both with and without prestimulus baseline ‘correction’, i.e. subtraction of the mean prestimulus (-200-0ms) ERP activity. Although prestimulus baseline subtraction is commonly used to minimise unwanted fluctuations, it can also distort ERPs following systematic preparatory (CNV) components (Koenig & Gianotti, 2009; van Leeuwen et al., 1998). While ERP components with baseline correction reflects the absolute change in neuronal activity evoked by stimuli, ERP

activity without baseline correction takes into account also the state of brain activity (Brandeis & Lehmann, 1986; Koenig & Gianotti, 2009; van Leeuwen et al., 1998). Previous analyses with and without prestimulus ERP subtraction have successfully been used in ERP studies: both approaches have successfully obtained ERP preparatory, attentional and inhibition components in ADHD. Consistent and interpretable topographic results have characterised CNV, N2 and P3 deficits in ADHD along with the corresponding sources without baseline correction in numerous studies and tasks (Albrecht et al., 2012; Doehnert et al., 2010; Doehnert et al., 2013; McLoughlin et al., 2010; McLoughlin et al., 2011). As the Fast Task has not previously been used in ERP studies, we take an empirical approach to examine P3 components both with and without prestimulus ERP correction.

All ERP averages contained at least 20 accepted sweeps. We analysed the area amplitude measures ($\mu\text{V}\cdot\text{ms}$) around two observable P3 peaks at Pz: early-P3 (250-450ms) and the late-P3 (450-600ms) (Figure 4-5a). Early- and late-P3 amplitudes were calculated as area under curve ($\mu\text{V}\cdot\text{ms}$) to reduce bias due to the varying noise levels induced by the different task conditions (Luck, 2005). The early-P3 is not to be confused with P3a in conventional ERP literature, which is associated with novelty and is more anteriorly distributed (Polich, 2007). Early-P3 amplitudes elicited in the Fast Task (in both conditions) is maximal in the parietal region (Figure 4-7). We also analysed the mean prestimulus ERP activity (μV) to explore its effects on preparatory processing and on post-stimulus ERPs (P3).

Table 4-1. Sample characteristics ADHD and controls at follow up

	ADHD (n=93)	Control (n=174)	t/ χ^2	<i>p</i>
Age, mean (SD)	18.28 (2.98)	17.76 (2.17)	1.56	0.16
Range	12-26	12-22		
Male, n (%)	78 (84%)	136 (77%)	1.38	0.24
IQ	95.72 (14.83)	109.5 (12.57)	-6.85	<0.01

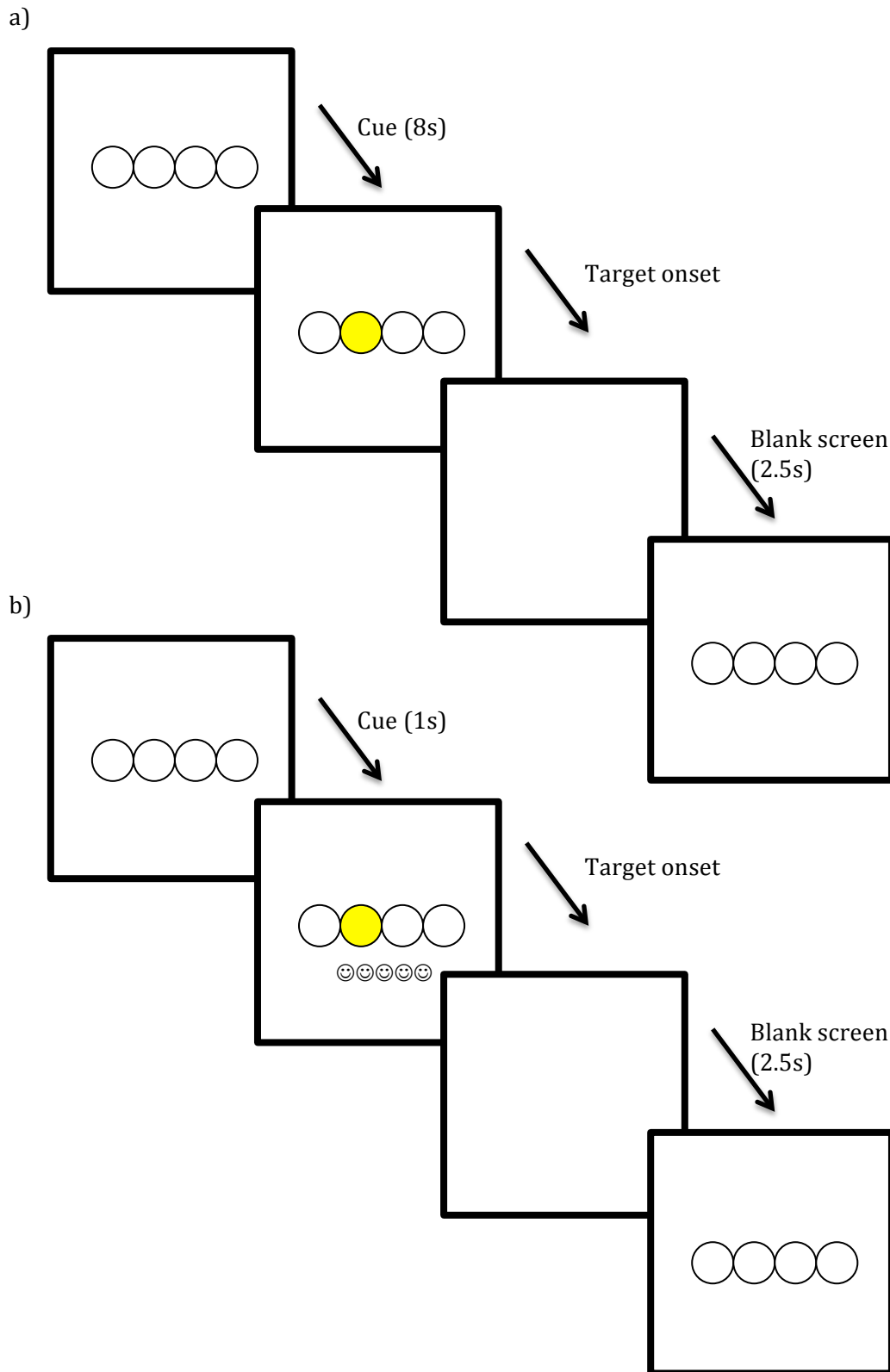

Figure 4-1. A schematic illustration of the temporal sequence of events in the a) baseline and b) fast-incentive conditions of the Fast Task.

4.3.5 Statistical analyses

All initial group analyses included IQ as a covariate; we subsequently re-ran analyses also without IQ as a covariate. Data were analysed using random intercept models in Stata, to control for genetic relatedness in a repeated-measures design, using a 'robust cluster' command to estimate standard errors (Tye et al., 2012; Wood et al., 2009a). This command was not available in the correlational and mediation analyses, so for these analyses we removed the siblings from the ADHD ($n=8$) and control ($n=81$) groups.

4.4 RESULTS

4.4.1 RTV

A random intercept model indicated significant main effects of group ($z=4.86, p<0.01$), and condition ($z=-10.39, p<0.01$) for RTV, and a significant group-by-condition interaction ($z=-2.60, p=0.01$) (Figure 4-2). Post-hoc regression analyses indicated increased RTV in individuals with ADHD compared to controls in the baseline ($t=5.31, df=178, p<0.001$) and fast-incentive ($t=3.43, df=178, p=0.001$) conditions. A paired sample *t*-test indicated a reduction in RTV from the baseline to the fast-incentive condition in both ADHD ($t=11.05, df=92, p<0.001$) and control ($t=7.51, df=173, p<0.001$) groups. We obtained comparable results using the length-matched segment of the baseline condition (Andreou et al., 2007) where individuals with ADHD displayed a significantly increased RTV in the baseline condition ($t=4.41, df=178, p<0.001$) and significantly greater improvement in the fast-incentive condition ($t=2.32, df=178, p=0.02$), compared to the controls.

4.4.2 Early-P3 (without prestimulus ERP subtraction)

A random intercept model revealed significant main effects of group ($z=-2.23, p=0.03$) and condition ($z=6.02, p<0.01$) for early-P3 amplitudes, and a significant group-by-condition interaction ($z=3.03, p=0.02$) (Figure 4-3). Post-hoc regression analyses revealed a significant group difference (lower early-P3 amplitude in cases) in the baseline condition ($t=-3.30, df=171, p=0.001$) (Figure 4-3, 4-6a and 4-7), which was not significant in the fast-incentive condition ($t=-0.24, df=171, p=0.81$) (Figure 4-3, 4-6b and 4-6). Paired-sample *t*-tests showed significant within-group change from the baseline to the fast-incentive condition in both ADHD ($t=-7.14, df=87, p<0.001$) and controls ($t=-4.09, df=171, p<0.001$).

4.4.3 Late-P3

For late-P3, a significant main effect emerged for condition ($z=-26.72, p<0.01$), but not for group ($z=-0.30, p=0.76$). Group by condition interaction or post-hoc analyses were not tested due to a lack of main effect of group. Paired sample *t*-tests showed a significant increase in late-P3 amplitudes in both ADHD ($t=14.46, df=87, p<0.001$) and controls ($t=28.47, df=171, p<0.001$) from the baseline to the fast-incentive condition (Figures 4-6b, 4-7).

4.4.4 Prestimulus ERP activity

A priori analyses were conducted to test for possible group differences in ERP activity before stimulus onset in each condition. The groups did not differ in prestimulus activity in the baseline condition ($z=-1.54, p=0.13$) (Figure 4-6a), but in the fast-incentive condition the control group exhibited significantly increased (in negativity) prestimulus activity compared to the ADHD group ($z=2.27, p=0.02$) (Figure 4-6b). Group-by-condition interaction was significant ($z=4.32, p<0.01$) (Figure 4-4). The

within-group change in prestimulus activity from the baseline to the fast-incentive condition was significant in the control ($t=10.20$, $df=171$, $p<0.001$) but not in the ADHD ($t=0.96$, $df=87$, $p=0.34$) group.

4.4.5 'Adjusted' early-P3 (with prestimulus ERP subtraction)

Given the significant group difference for prestimulus ERP activity reported above, additional analyses were run to examine early-P3 amplitudes with prestimulus ERP subtraction. This adjusted measure captures only the change in neuronal activity following onset of the target stimuli, without the prestimulus activity.

A random intercept model showed main effects of group ($z=-2.20$, $p=0.03$) and condition ($z=43.73$, $p<0.01$) for the adjusted early-P3, but the group-by-condition interaction was not significant ($z=0.93$, $p=0.35$) (Figure 4-5). Individuals with ADHD had significantly lower amplitudes for adjusted early-P3 in the baseline condition ($t=-2.56$, $df=171$, $p=0.01$), but not in the fast-incentive condition ($t=-1.03$, $df=171$, $p=0.31$). The change in adjusted early-P3 amplitudes between conditions was significant in both the ADHD ($t=-39.53$, $df=87$, $p<0.001$) and control ($t=-30.43$, $df=171$, $p<0.001$) groups.

All analyses were re-run without IQ as a covariate, and the pattern of results remained the same with one exception: the main effect of group for adjusted early-P3 diminished ($z=-1.63$, $p=0.10$).

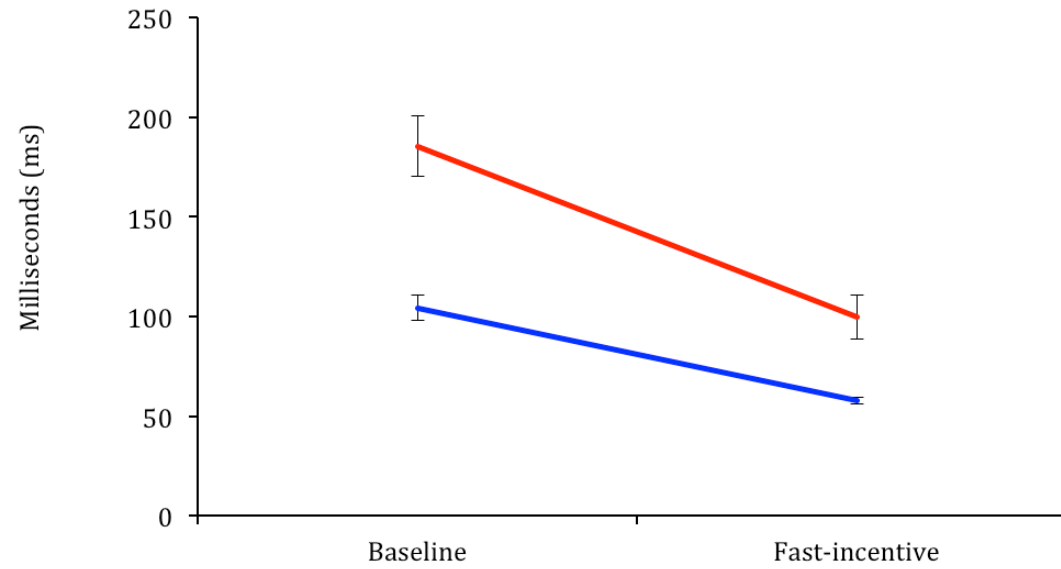

Figure 4-2. Reaction time performance across the baseline and the fast-incentive conditions (with standard errors) in ADHD (red line) and controls (blue line)

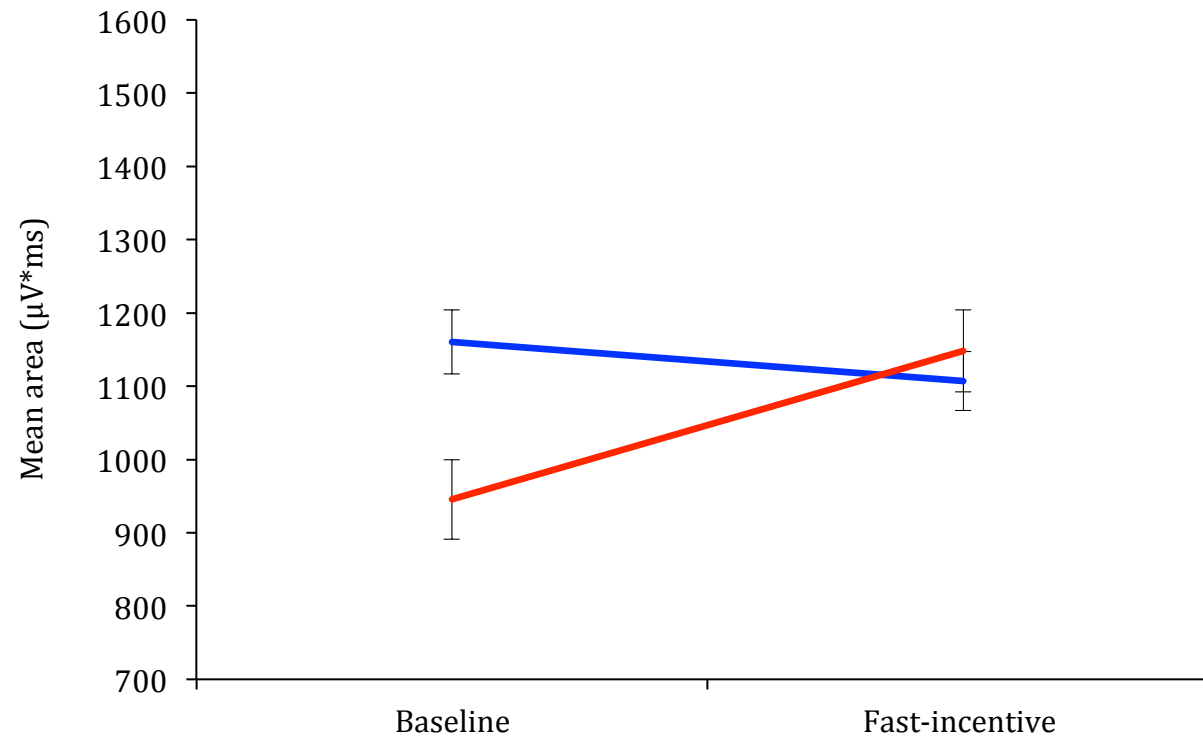

Figure 4-3. Unadjusted early-P3 amplitudes across the baseline and the fast-incentive conditions (with standard errors) in ADHD (red line) and controls (blue line)

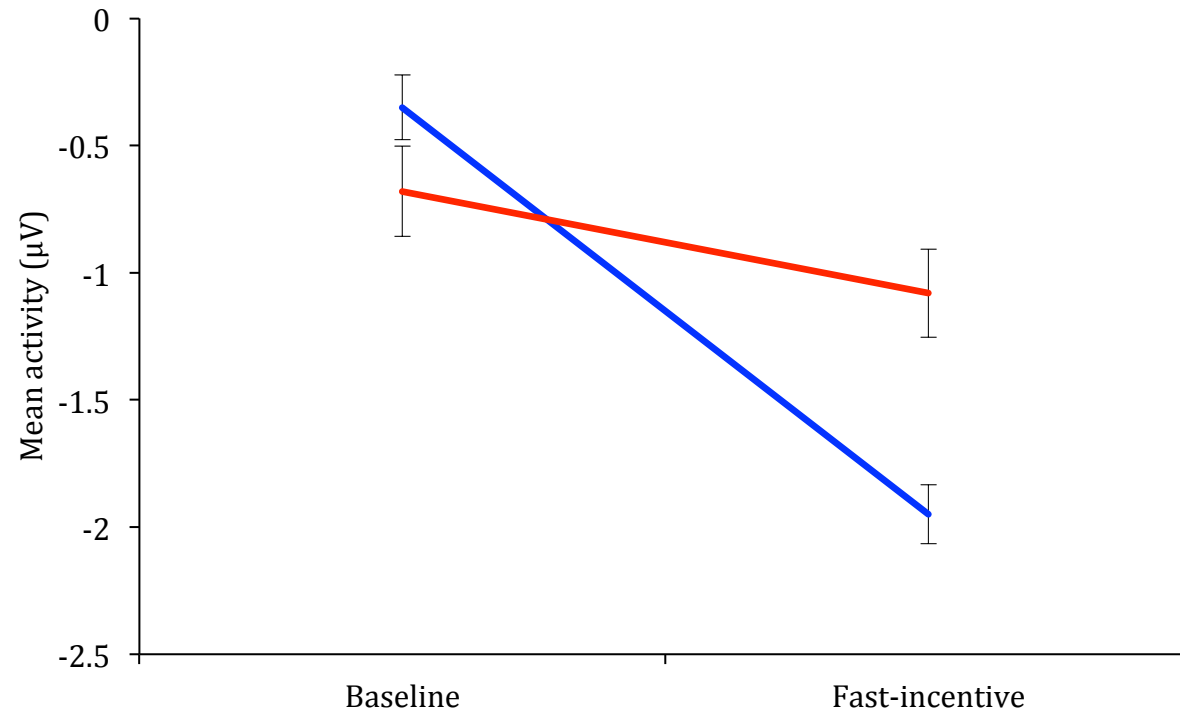

Figure 4-4. Prestimulus ERP activity across the baseline and the fast-incentive conditions (with standard errors) in ADHD (red line) and controls (blue line)

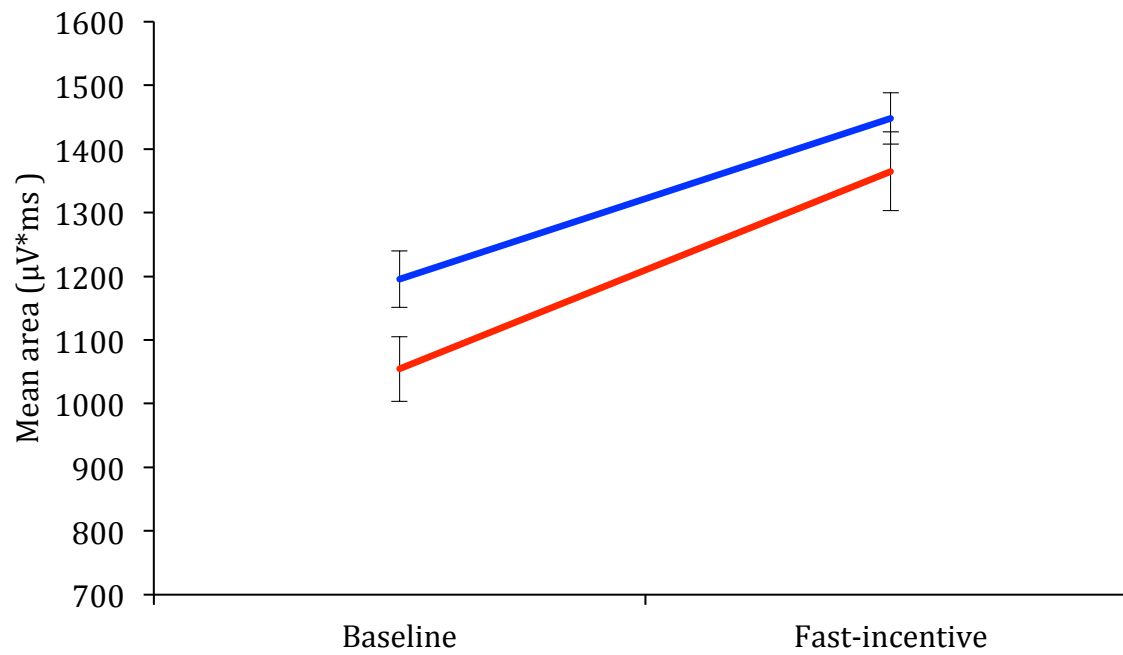

Figure 4-5. Adjusted early-P3 amplitudes across the baseline and the fast-incentive conditions (with standard errors) in ADHD (red line) and controls (blue line)

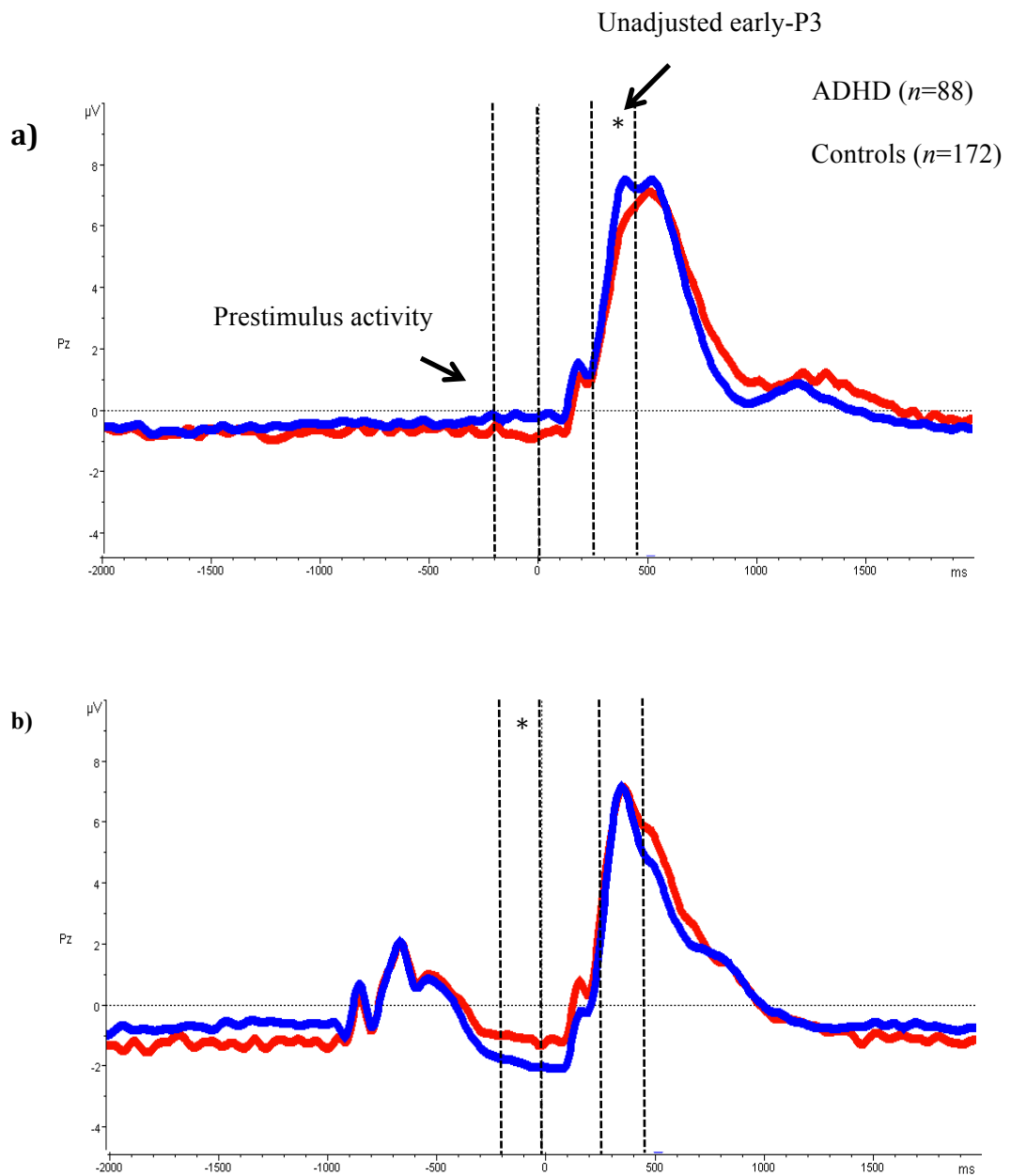

Figure 4-6. ERP waveforms of the ADHD and control groups in the (a) baseline and (b) fast-incentive conditions.

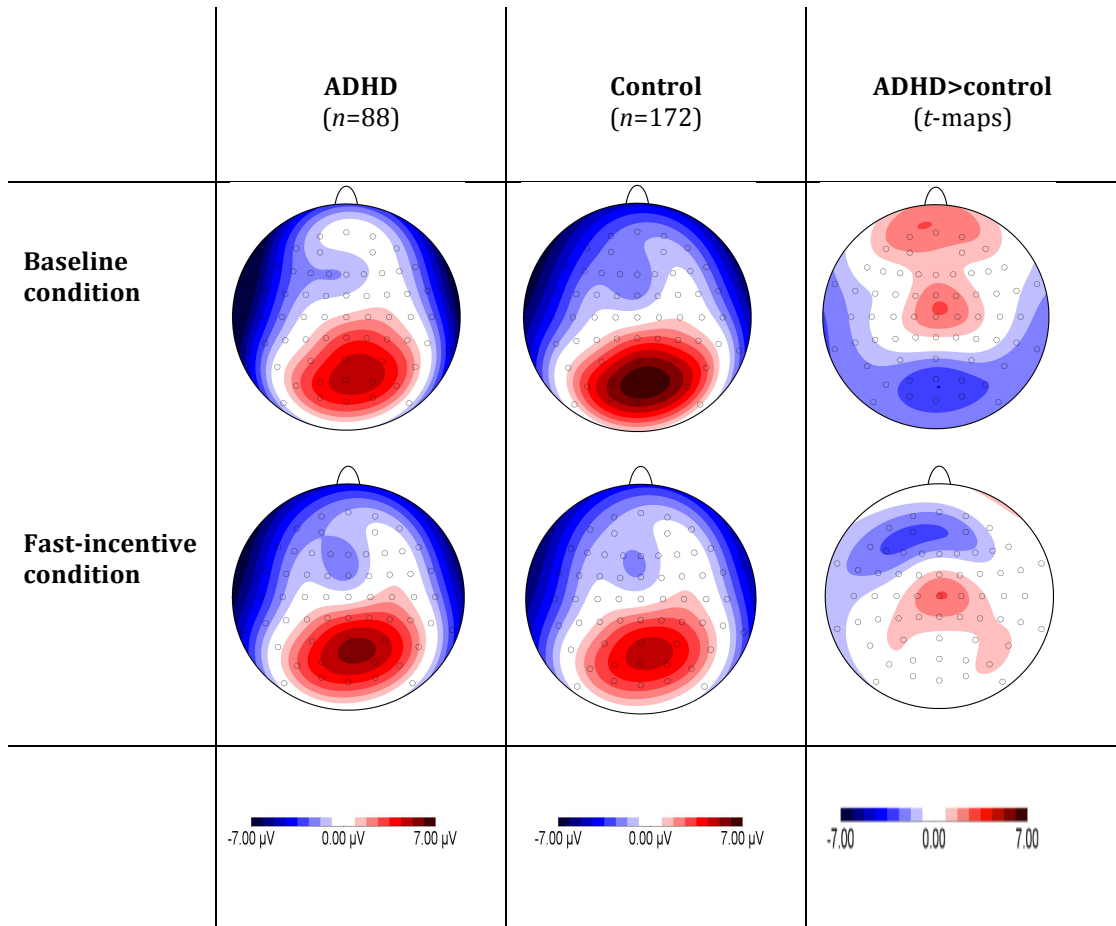

Figure 4-7. Topographical and t-maps of the early-P3 (250-450ms) (without prestimulus ERP subtraction) in the ADHD and control groups in the baseline and fast-incentive conditions

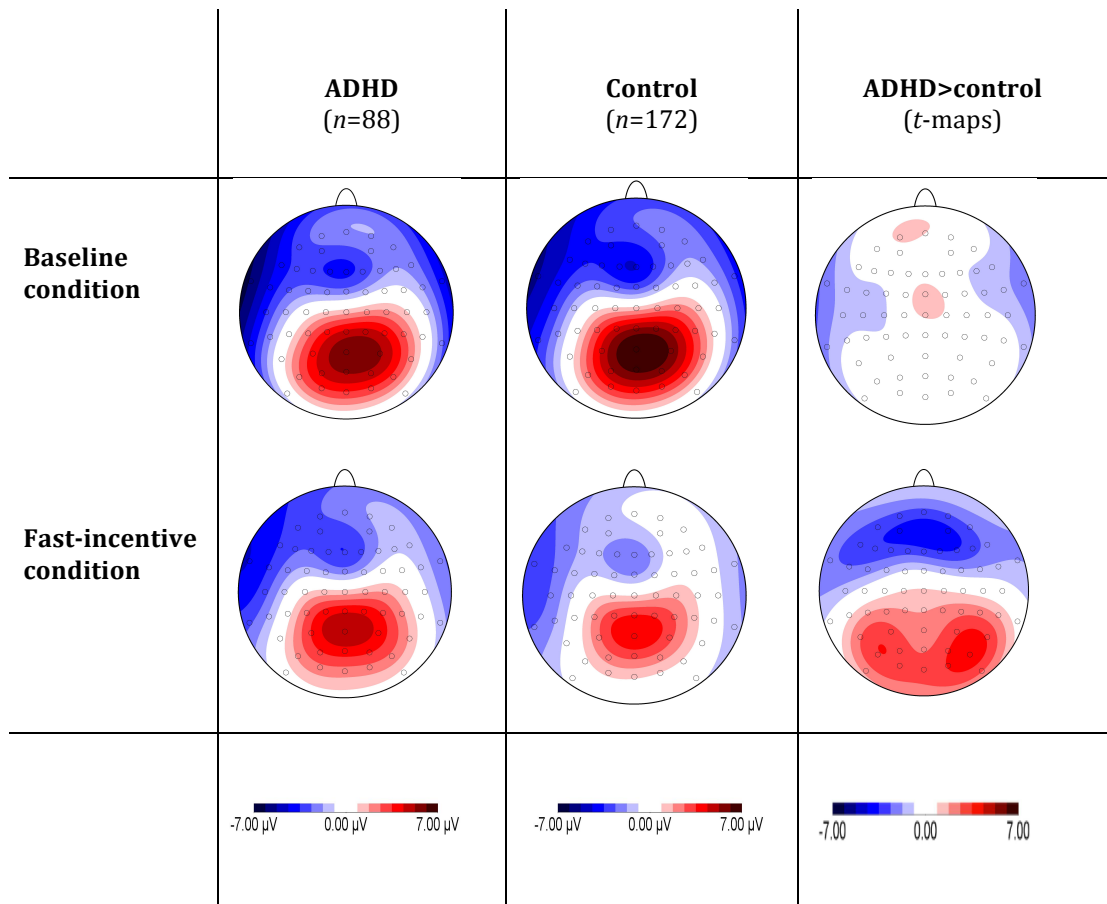

Figure 4-8. Topographical and t-maps of the late-P3 (450-600ms) without prestimulus ERP subtraction in the ADHD and control groups in the baseline and fast-incentive conditions

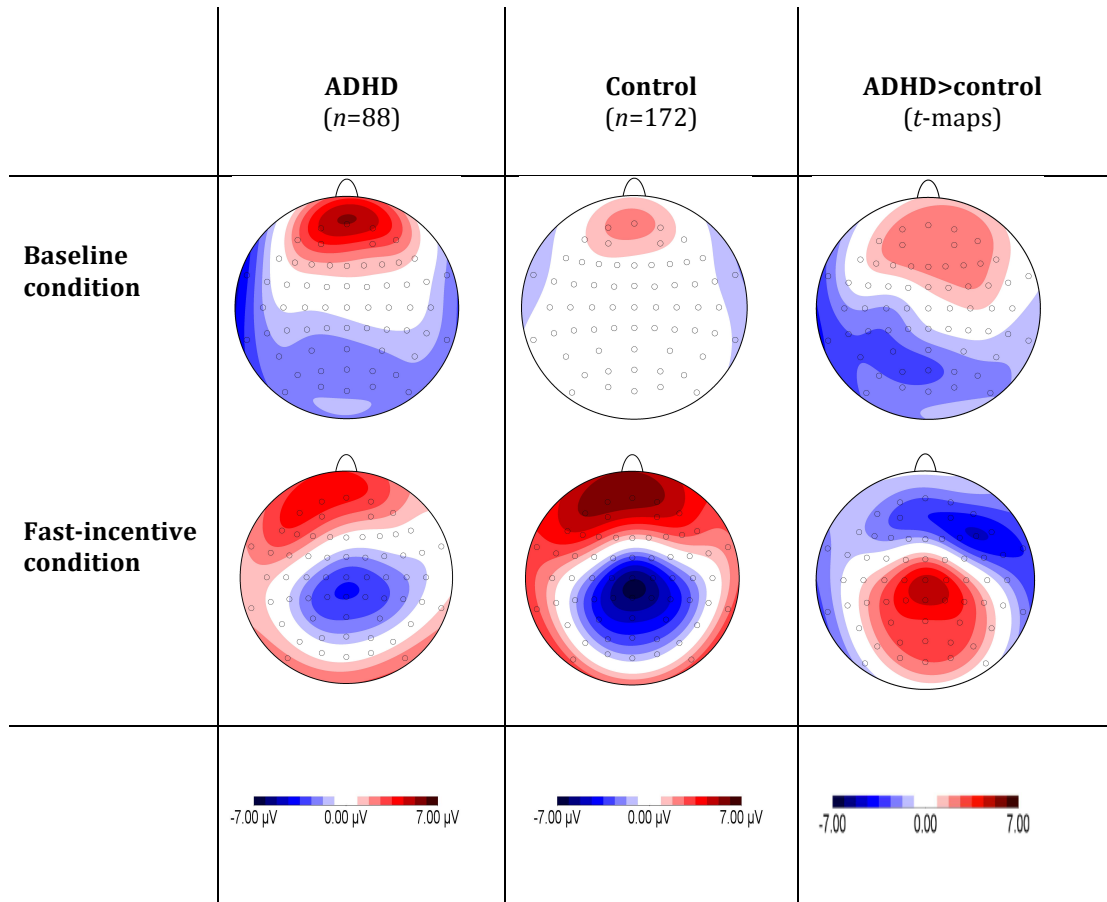

Figure 4-9. Topographical and t-maps of the prestimulus ERP activity (-200-0ms) in the ADHD and control groups in the baseline and fast-incentive conditions

4.4.6 Relationship between prestimulus ERP activity, early-P3 and RTV

4.4.6.1 Correlations

As age correlated significantly with the ERP variables within each group, and gender with RTV in the ADHD group, they were included as covariates in the within-group correlational analyses, in addition to IQ. As the two task conditions elicit different prestimulus activity, we explored the correlations with early-P3 both with and without prestimulus ERP subtraction (adjusted and unadjusted early-P3) (Table 4-2). In the ADHD group, the unadjusted early-P3 showed a significant negative association with RTV only in the fast-incentive condition, while RTV correlated negatively with the adjusted early-P3 component in both task conditions. In the control group none of the correlations between RTV and early-P3 were significant. Prestimulus ERP activity correlated significantly with unadjusted (but not adjusted) early-P3 in the baseline condition in both groups, whereas in the fast-incentive condition prestimulus activity significantly correlated with adjusted (but not unadjusted) early-P3 in both groups. The only significant correlation that emerged between prestimulus activity and RTV was for the control group in the fast-incentive condition. We then re-ran the correlations without controlling for the effects of IQ, and the overall pattern of results was similar (Table 4-3).

Table 4-2. Pearson correlations (two-tailed) between prestimulus activity, unadjusted early-P3 amplitudes (without prestimulus ERP subtraction), adjusted early-P3 amplitudes (with prestimulus ERP subtraction) and reaction time variability (RTV), controlling for effects of age, gender and IQ.

	Prestimulus activity	Unadjusted early-P3	Adjusted early-P3	RTV
ADHD				
Prestimulus activity	1	0.19	-0.41**	0.05
Unadjusted early-P3	0.47**	1	0.81**	-0.31**
Adjusted early-P3	-0.18	0.74**	1	-0.27*
RTV	0.16	-0.10	-0.28*	1
Control				
Prestimulus activity	1	0.10	-0.40**	0.27*
Unadjusted early-P3	0.43**	1	0.86**	-0.07
Adjusted early-P3	-0.04	0.85**	1	-0.18
RTV	0.08	-0.06	-0.08	1

**** p<0.01, * p<0.05**

Correlations in the baseline condition are presented below the diagonals, and the correlations in the fast-incentive condition are presented above the diagonals.

Table 4-3. Pearson correlations (two-tailed) between prestimulus activity, unadjusted early-P3 amplitudes (without prestimulus ERP subtraction), adjusted early-P3 amplitudes (with prestimulus ERP subtraction) and reaction time variability (RTV), without controlling for effects of IQ.

	Prestimulus activity	Unadjusted early-P3	Adjusted early-P3	RTV
ADHD				
Prestimulus activity	1	0.18	-0.44**	0.13
Unadjusted early-P3	0.46**	1	0.80**	-0.31**
Adjusted early-P3	-0.19	0.74**	1	-0.30**
RTV	0.17	-0.11	-0.30**	1
Control				
Prestimulus activity	1	0.10	-0.42**	0.32**
Unadjusted early-P3	0.43**	1	0.86**	-0.06
Adjusted early-P3	-0.04	0.85**	1	-0.20
RTV	0.08	0.07	-0.08	1

**** p<0.01, * p<0.05**

Correlations in the baseline condition are presented below the diagonals, and the correlations in the fast-incentive condition are presented above the diagonals.

4.4.6.2 Mediation

As the adjusted early-P3 amplitude was significantly associated with both prestimulus ERP activity and RTV in the ADHD group, the Sobel-Goodman test was conducted to examine the mediational relationship between these three related variables. The same analysis was also performed in the control group to test if there was a significant direct effect between prestimulus ERP activity and RTV, or whether this relationship was partially mediated by the adjusted early-P3.

Within-group analyses were first run controlling for the effects of age, gender and IQ. The mediation effect was significant in the ADHD group ($z=1.94$, $p=0.05$), with no significant direct effect between prestimulus activity and RTV ($z=-0.54$, $p=0.59$) (Figure 4-10a). In the control group, no significant mediation effect emerged ($z=0.78$, $p=0.43$), but we observed a significant effect between prestimulus activity and RTV ($z=1.96$, $p=0.05$) (Figure 4-10b). These analyses were then re-ran without controlling for IQ: the mediation effect in the ADHD group and the direct effect in the control group remained significant ($z=2.07$, $p=0.04$; $z=2.50$, $p=0.01$, respectively).

a) ADHD

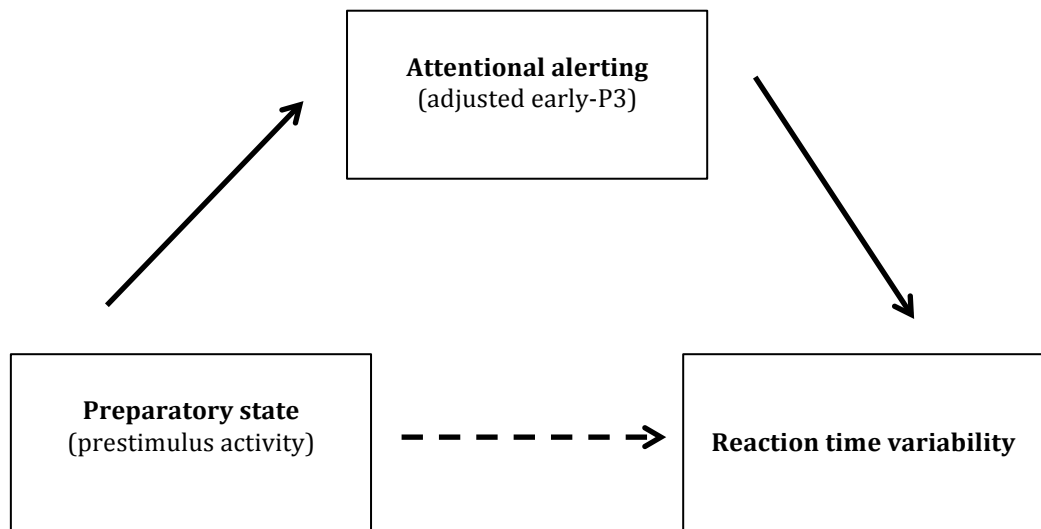

b) Control

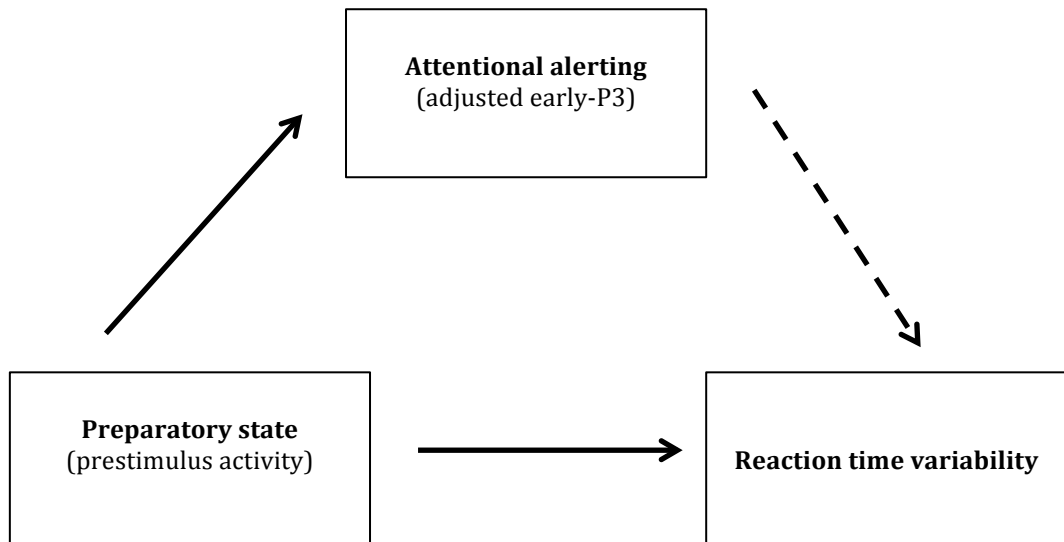

Figure 4-10. Neurophysiological pathways to improved RTV. Mediation models in the (a) ADHD and (b) control groups in the fast-incentive condition.

Solid lines depict significant paths ($p \leq 0.05$) and dotted lines depict non-significant paths ($p > 0.05$).

4.5 DISCUSSION

We show, first, that ADHD is associated with attenuated early-P3 amplitudes, indicating difficulties with attentional resource allocation (Polich, 2007). Second, we show that, in a fast-paced, rewarded condition, individuals with ADHD can enhance their attentional allocation (early-P3) to levels indistinguishable from controls. Yet, third, the brain processes in individuals with ADHD are not fully comparable to controls in the fast, rewarded condition, as the adjustment in the prestimulus activity observed in the controls was absent in the ADHD group. A further step-by-step consideration of how the ERP results link to RTV reveals how ADHD and control groups recruit different neurophysiological pathways to improved RTV.

When we additionally examined group differences in attentional allocation (early-P3) with effects of prestimulus activity removed (adjusted early-P3), the impairment in the ADHD group was still observed in the baseline condition, indicating difficulties with ‘attentional alerting’. There was no group difference on the adjusted early-P3 in the fast-incentive condition, but both groups significantly improved between conditions and the group-by-condition interaction was not significant. The pattern of findings therefore indicates that the fast-incentive condition elicited attentional alerting in both ADHD and control groups, to a similar degree, but an additional increase in preparatory activity was only seen in the control group.

Overall, the ERP results showed that ADHD was associated with impairments in early-P3 in the baseline condition (with or without effects of prestimulus ERP activity removed), and with prestimulus ERP activity in the fast-incentive condition. The only significant correlation with RTV in the baseline condition in the ADHD group was with the adjusted early-P3, leading us to conclude that it is specifically difficulties with

attentional alerting (the *change* in neuronal activity following a target) that underlie the high RTV in ADHD. In the fast-incentive condition, where RTV improves, the role of the preparatory state becomes important: among controls, we observed a significant correlation between prestimulus activity and RTV, but this correlation was absent in ADHD. A mediation analysis confirmed that the control group achieved optimal RTV by directly increasing preparatory activity, while in ADHD this was mediated by increased attentional alerting. The overall pattern of findings suggests that the inability to adjust the preparatory state in a changed context may explain why RTV does not fully normalise in ADHD.

The temporal precision of EEG enabled us to identify the steps where the neurophysiological pathways diverge for individuals with ADHD and controls that lead to performance fluctuations (RTV). Our empirical investigation of the prestimulus ERP activity and its effects on post-stimulus ERPs highlights the importance of examining post-stimulus topographies both with and without the conventional prestimulus correction for ERP studies using novel ERP paradigms. The prestimulus ERP activity in the fast-incentive condition had a contingent negative variation (CNV)-like topography (negative polarity at Cz) (Figure 4-9), which reflects neural preparation (Albrecht et al., 2012; Doehnert et al., 2010; Doehnert et al., 2013; McLoughlin et al., 2010). However, the prestimulus period during the baseline condition (with a long ISI) of the Fast Task may reflect neurophysiological processes in addition to preparatory activity, as a typical CNV-like distribution was not observed (Figure 4-9). The relationship between prestimulus ERP activity (CNV) and post-stimulus ERP (e.g. P3) have previously been analysed and discussed in GNG tasks (Koenig & Gianotti, 2009; Oddy, Barry, Johnstone, & Clarke, 2005; Roberts, Rau, Lutzenberger, & Birbaumer, 1994; Simson, Vaughan, & Ritter, 1977). In the present study, we show that prestimulus ERP effects can be

generalised to other simple choice reaction time tasks. The temporal precision of the ERP analyses further allowed us to distinguish between early and late stages of attentional processing (early- vs late-P3) with the latter relatively unimpaired in ADHD.

A limitation of this study was that, while the two task conditions were matched on the number of trials, they differed in task length and we were unable to perform additional ERP analyses on length-matched segments due to insufficient number of trials. As such, while our findings illustrate how attentional performance can be improved in ADHD, future studies are needed to investigate how such improvements can be maintained longer term. At the performance level (RTV), we obtained identical findings whether or not length-matched segments were used.

Overall, our findings provide novel insights into the neurophysiological basis of the attentional fluctuation observed as high RTV. Consistent with our previous genetic model fitting finding that RTV baseline performance and its improvement across conditions measure the same aetiological process (Kuntsi et al., 2012), findings from this study show that the same neurophysiological process underlies RTV baseline performance and its improvement in ADHD. Although this and previous studies suggest that attenuated early-P3 amplitudes and increased RTV are developmentally stable markers of ADHD (Halperin et al., 2008; Szurmi et al., 2011), both show malleability and are therefore targets for non-pharmacological interventions. The apparent inability in individuals with ADHD to adjust the preparatory state in a changed context remains a particular challenge for intervention efforts.

CHAPTER 5 – WHICH CHILDHOOD SYMPTOMS, FAMILY BACKGROUND AND COGNITIVE MEASURES PREDICT FUTURE ADHD OUTCOME?

5.1 ABSTRACT

Attention-deficit/hyperactivity disorder (ADHD) persists in around two-thirds of cases. Yet, it remains unclear which childhood predictors and compensatory processes are related to adolescent and adult outcomes in ADHD. This study examines the predictive value of childhood factors on ADHD outcome, by considering ADHD outcome as both a continuous measure of symptoms and impairment, and as a categorical diagnosis of ADHD persistence vs remittance. We followed up participants (n=116) with childhood DSM-IV ADHD diagnosis approximately 6 years later. ADHD outcome variables were based on interview-based parent-reported ADHD symptoms and parent ratings of impairment. Childhood predictors were parent and teacher ratings on ADHD symptoms and co-occurring behaviours; actigraph measures of activity level; socio-economic status (SES); and cognitive measures of IQ, digit span, reaction time variability, commission errors, omission errors and choice impulsivity. Higher parent-rated ADHD symptoms and movement intensity in childhood, but not teacher-rated symptoms, predicted ADHD symptoms at follow up. Co-occurring symptoms of oppositional behaviours, anxiety, social and emotional problems were also significant predictors, but these effects disappeared after controlling for ADHD symptoms in childhood. SES and IQ were significant predictors for both ADHD symptoms and impairment at follow up. The diagnosis-based comparisons indicated significantly lower SES and greater social problems at childhood among persisters than remitters in childhood, but no other significant group differences emerged. Overall, our findings emphasise the role of IQ and SES in the developmental outcome of ADHD. Further research should examine the extent to which these factors moderate future ADHD severity.

5.2 INTRODUCTION

Symptoms of attention-deficit/hyperactivity disorder (ADHD) decline with age (Biederman et al., 2000; Faraone et al., 2006a), yet around two-thirds of individuals with childhood ADHD continue to be affected by ADHD symptoms and show clinical impairments in adolescence and adulthood (Faraone et al., 2006a; Langley et al., 2010). The rate of persistence varies by ADHD subtype, with individuals diagnosed with combined-type ADHD in childhood demonstrating the highest rates of persistence (Lara et al., 2009). ADHD in childhood is also a risk factor for negative developmental outcomes, such as substance abuse, antisocial behaviour and poor social relationships (Barkley et al., 2002; Biederman et al., 1996). However, it remains unclear which childhood predictors and compensatory processes are related to adolescent and adult outcomes in ADHD. Identifying the factors in childhood that predict ADHD outcome in adolescence and adulthood is important for early detection and intervention.

Earlier studies that focused mainly on conduct disorder found that co-occurring aggression or conduct problems in childhood predicted persistence of ADHD into adolescence and adulthood (Gittelman, Mannuzza, Shenker, & Bonagura, 1985; Loney et al., 1981; Taylor, Chadwick, Heptinstall, & Danckaerts, 1996). A more recent study focusing on a larger cohort of ADHD participants and a wider range of childhood risk factors revealed that psychiatric comorbidity (e.g. oppositional defiant disorder, conduct disorder and anxiety disorder), severity of childhood symptoms, maternal psychopathology and psychosocial adversity significantly predicted persistence in ADHD in adolescence and adulthood (Biederman et al., 2011). Although two studies have separately suggested socio-economic status (SES) as an important predictor for persistence of hyperactivity symptoms in children (Loney et al., 1981) and outcome

severity in early adolescence (Molina et al., 2009), this finding has not always been replicated (Biederman et al., 2009; Hart et al., 1995).

A growing number of studies have moved beyond behavioural and environmental factors to examine the predictive value of cognitive functions in ADHD persistence. Although findings from a recent systematic review found both ADHD persisters and remitters to perform significantly worse than controls on all domains of cognitive measures at follow up (van Lieshout et al., 2013), some initial evidence suggested that cognitive functions in early childhood predicted future ADHD symptoms or diagnosis a few years later (Brocki et al., 2007; Campbell & von Stauffenberg, 2009; Kalff et al., 2002). However, none of these studies had examined whether they predict future ADHD outcome in older children, adolescents or in adults (van Lieshout et al., 2013). IQ in early childhood predicted later ADHD symptoms measured in middle childhood (age 7.5) (Brocki et al., 2007) or in early adolescence (age 14) (Molina et al., 2009), but this was not replicated in another follow-up study in adolescence (ages 12-18), which found childhood IQ and social class to predict conduct disorder outcomes rather than ADHD scores or diagnosis (Langley et al., 2010).

Following a large group of individuals with childhood ADHD, who have previously demonstrated impairment in cognitive measures of reaction time variability (RTV), go/no-go task commission (CE) and omission (OE) errors and choice impulsivity (Kuntsi et al., 2010), and had higher mean and variability of objectively measured actigraph movement intensity and count (Wood et al., 2009b), the present study aims to examine which behavioural (parent and teacher ratings of ADHD symptoms, co-occurring symptoms of oppositional behaviours, anxiety, social and emotional problems and actigraph movement), SES and cognitive measures predict ADHD outcome at follow

up. We examine ADHD outcome both as a continuous measure of symptoms and impairment, and as a categorical diagnosis of persistence or remittance.

5.3 METHODS

5.3.1 Sample

Participants who had taken part in our previous research (UK-London sub-sample of an international collaboration (Chen et al., 2008; Kuntsi et al., 2010)) were invited to take part in this study. Here we focus on ADHD probands and their siblings, who had a clinical diagnosis of DSM-IV combined-type ADHD during childhood. Childhood ADHD was assessed based on the Parental Account of Childhood symptoms (PACS) (Chen et al., 2008; Taylor et al., 1986a; Taylor, Schachar, Thorley, & Wieselberg, 1986b), a semi-structured, standardised, investigator interview with high inter-rater reliability (Taylor et al., 1986a). Exclusion criteria applied at the initial childhood assessment included IQ<70, autism, epilepsy, general learning difficulties, brain disorders and any genetic or medical disorder associated with externalising behaviours that might mimic ADHD.

Of the 128 eligible families with clinical, behavioural, actigraph and cognitive data in childhood, we assessed 80 families (63%) and an additional 42 families who had childhood clinical and IQ data without additional childhood cognitive or actigraph data. Of the 118 participants re-assessed at follow-up, 87 (79%) were classified as ADHD persisters as these individuals continued to meet full DSM-IV ADHD criteria in adolescence/adulthood. Among the persistent ADHD group, 60% (n=52) met criteria for the combined subtype, 32% (n=28) met criteria for predominantly inattentive subtype and 8% (n=7) met criteria for predominantly hyperactivity-impulsivity subtype at follow up. Of the 23 'remitted' participants, 9 (8%) did not meet symptom criteria (displayed less than 6 items in either inattention or hyperactivity-impulsivity domains)

and were not clinically impaired, 14 displayed five or more items on either the inattention or hyperactivity-impulsivity symptom domains, but did not show functional impairment (less than two domains), 2 met criteria of clinical impairment but not on the symptom level, these two participants had different cognitive profiles compared to the other individuals from the remitted group (Appendix C), therefore they excluded from the analyses to minimise heterogeneity in the sample. Six individuals had missing data on parent-reported functioning impairment and were excluded from all group analyses, as their diagnostic status could not be determined.

The final sample consisted of 110 individuals (10 sibling pairs and 90 singletons). The mean age was 11.81 years (S.D. = 2.91, range 6-17) at the baseline assessment and 18.48 (S.D. = 2.98, range 12-26) at follow up. There were no significant differences between those lost to follow up and those who participated in the follow up on baseline age, gender, IQ or ADHD symptoms (Table 5-1), but those who were lost to follow up had significantly lower SES ($\chi^2 = 10.02$; $p=0.04$). At follow up, the ADHD-persistent, ADHD-remittent and control groups did not differ in age ($F=2.05$, $df=2$, 192; $p=0.20$), but there were significantly more males in the remitted group than the other two groups ($\chi^2 = 7.65$, $p=0.02$) (Table 5-2).

Table 5-1. Sample characteristics between participants (individuals who were successfully reassessed) and non-participants (individuals lost to follow-up).

	Participants (n=110)	Non-participants (n=50)	t/ χ^2	<i>p</i>
Mean age (SD)	11.81 (2.91)	11.86 (2.61)	0.11	0.92
Male, n (%)	103 (87%)	46 (92%)	0.77	0.38
Mean ADHD symptoms (SD)	81.21 (8.87)	81.28 (9.27)	0.04	0.97
Mean IQ (SD)	100.32 (16.76)	99.31 (17.99)	-0.83	0.41

Table 5-2. Sample characteristics between ADHD persisters and remitters at follow-up.

	ADHD remitters (n=23)	ADHD persisters (n=87)	t/ χ^2	p
Mean age (SD)	18.89 (3.06)	18.27 (3.03)	0.87	0.39
Male, n (%)	23 (100%)	72 (83%)	4.59	0.03
Mean ADHD symptoms (SD)	9.71 (4.16)	14.14 (2.83)	4.76	<0.01
Functional impairment (SD)	5.57 (3.64)	16.44 (5.32)	6.73	<0.01

5.3.2 Procedure

5.3.2.1 Initial assessment

Families were invited to the research centre for cognitive assessments, which included a simultaneous actigraph assessment and a parent interview (Kuntsi et al., 2010; Wood et al., 2009b). The total length of the test session, including breaks, was approximately 2.5 hours. A minimum of a 48-hour medication-free period before testing was required. The ADHD proband and sibling of each family were tested simultaneously in separate testing rooms by trained researchers.

5.3.2.2 Follow-up assessment

Participants were re-contacted by telephone and scheduled for a follow-up clinical interview and a cognitive-EEG assessment with simultaneous actigraph assessment at the same research centre where the initial assessment took place. When sibling pairs were tested, the assessments were carried out in separate rooms. The order of tasks was fixed. For those prescribed stimulants, a 48-hour ADHD medication-free period was required for cognitive and EEG testing. The total length of the test session, including breaks, was approximately 4-4.5 hours. Face-to-face or telephone clinical interviews were administered to the parent of each ADHD proband shortly before or after the participant's assessment.

5.3.3 Measures

5.3.3.1 Childhood measures

ADHD ratings. Inattentive and hyperactive-impulsive symptoms were measured using the Long Version of Conners' Parent Rating Scale (Conners et al., 1998a) and the Long Version of Conners' Teacher Rating Scale (Conners et al., 1998b). On both the parent and teacher Conners' scales, summing the scores on the nine-item hyperactive-

impulsive and nine-item inattentive DSM-IV symptoms subscales forms a total DSM-IV ADHD symptoms subscale.

Co-occurring symptoms. Oppositional behaviours, social problems and emotional lability were measured using the subscales of the Long Version of Conners' Parent Rating Scale (Conners et al., 1998a) and the Long Version of Conners' Teacher Rating Scale (Conners et al., 1998b). Social communication was measured using the parent-rated Social Communication Questionnaire (SCQ) (Goodman, 1997).

Actigraph measures of activity level (Wood et al., 2009b). The actigraph readings used in the current analyses are taken from a laboratory-based test session, when the siblings were apart completing a short-form IQ test and several cognitive-experimental tasks, under the supervision of separate experimenters who administered standardised instructions. The total length of the testing session was approximately 2 hours, excluding a 25-minute unstructured break, given approximately halfway through the session.

The children wore two actigraphs: one on the dominant leg and the other on the waist (Wood et al., 2009b). Four actigraph measures from each participant were used: the cumulative intensity of movements (mean actigraph intensity), number of movements (mean actigraph count), intra-individual variability (IIV; individual's standard deviation (SD) in minute-to-minute readings) of intensity and the number of movements (IIV actigraph count) from the dominant ankle and the waist.

Socio-economic status (SES). Socio-economic status was measured based on parental occupational status (employed or unemployed) and types of occupation based on the

parent with higher occupational class. The five occupational classes were defined as follows: 1=unemployed or unclassified or not in search of jobs (e.g. housewife/husband, disabled/on disability allowance) (n=0); 2=employed laborer (n=6); 3=employed in service or sales (n=37); 4=clerical workers (n=18); and 5 employed professionals (n=47).

Wechsler Intelligence Scales for Children, Third Edition (WISC-III) (Wechsler, 1991). The vocabulary, similarities, picture completion and block design subtests from the WISC-III were used to obtain a prorated estimate of the child's IQ (Sattler, 1992). The digit span subtest from the WISC-III was administered to obtain digit span forward (verbal short-term memory) and digit span backward (verbal working memory) (Wechsler, 1991).

The Go/No-Go (GNG) task (Borger & van der Meere, 2000; Kuntsi et al., 2005a). On each trial, one of two possible stimuli appeared for 300ms in the middle of the computer screen. The participant was instructed to respond only to the 'go' stimuli and to react as quickly as possible, but to maintain a high level of accuracy. The proportion of 'go' stimuli to 'no-go' stimuli was 4:1. The participants performed the task under three conditions (slow, fast and incentive), matched for length of time on task. Herein we present data from the slow condition, which had an inter-stimulus interval (ISI) of 8s and consisting of 72 trials, and the fast condition, with an ISI of 1s and consisting of 462 trials. The order of presentation of the slow and fast conditions varied randomly across participants. In this study we focus on standard deviation of RTs (RTV), commission errors (CE) and omission errors (OE), as these variables were most strongly associated with ADHD at initial assessment (Kuntsi et al., 2010).

The Fast Task (Andreou et al., 2007; Kuntsi et al., 2006b). The baseline condition consists of 72 trials, which followed a standard warned four-choice RT task. Four empty circles (warning signals, arranged horizontally) first appeared for 8s, after which one of them (the target) was coloured in. Participants were asked to press the response key that directly corresponded to the position of the target stimulus. Following a response, the stimuli disappeared from the screen and a fixed inter-trial interval of 2.5s followed. Speed and accuracy were emphasised equally in the task instructions. If the child did not respond within 10s, the trial terminated. A comparison condition of 80 trials with a fast event rate (1s) and incentives followed the baseline condition (Andreou et al., 2007). The variable obtained from the task is RTV, herein reported for the baseline condition only.

To limit the total number of variables and to create psychometrically robust variables based on previous analyses on the same sample (Kuntsi et al., 2010), the summed unstandardised scores of RTV were obtained across the baseline conditions of the GNG and the Fast Task. A composite measure of CE and OE were obtained by summing the raw CE scores from both the slow and the fast conditions of the GNG task.

The Maudsley Index of Childhood Delay Aversion (Kuntsi et al., 2006a; Paloyelis et al., 2009). Two conditions, each with 20 trials, were administered. In each trial, the child had a choice between a smaller-immediate reward (one point involving a 2-second pre-reward delay) and a larger-delayed reward (two points involving a 30-second pre-reward delay). In the no post-reward delay condition, choosing the small reward led immediately to the next trial, reducing the overall length of the condition. In the post-reward delay condition, choosing the small reward led to a delay period of 30 seconds, and choosing the large reward led to a delay period of 2 seconds before the next trial.

The order of the two conditions was randomly chosen for each twin. Choice impulsivity (CI) was calculated here as the number of times the smaller-immediate reward was selected in the no post-reward delay condition, controlling for total number of trials attempted.

5.3.3.2 Follow-up measures

Diagnostic Interview for ADHD in adults (DIVA) (Kooij & Francken, 2007). This structured interview conducted by trained researchers is based on the DSM-IV criteria for ADHD and provides a list of concrete and realistic examples, for both current and retrospective behaviour. The DIVA was conducted with both the ADHD proband and his/her parent separately.

Barkley's functional impairment scale (BFIS) (Barkley & Murphy, 2006c). This 10-item scale is used to assess the levels of functional impairments commonly associated with ADHD symptoms in five areas of their everyday life: family/relationship; work/education; social interaction; leisure activities and management of daily responsibilities. Each item ranged from 0 (never or rarely) to 3 (very often).

Participants were classified as 'affected', if they scored a 'yes' on ≥ 6 items on the DIVA for either inattention or hyperactivity-impulsivity based on parent report, and scored ≥ 2 on two or more areas of impairments on the BFIS, rated by their parent.

5.3.3.3 Statistical analyses

We analysed the predictive values of the childhood variables using two analytic steps. First, we ran exploratory linear and logistic regressions to identify the childhood variables that are associated, at follow-up, with (1) ADHD severity, defined as i) a

continuous measure of ADHD symptoms based on the parent DIVA scores, ii) parent-report on Barkley's functional impairment; and with (2) ADHD status (persisters vs remitters) at follow up. Second, we conducted a canonical correlation analysis to determine the degree of association between two sets of variables: i) childhood predictors and ii) ADHD symptoms/ clinical impairments at follow up. As a large sample size is required for the canonical correlation analysis, we imputed missing data from the variables with available data, using Stata version 10.0 (Stata Corporation, College Station, TX).

Age at initial assessment was regressed from all behavioural and cognitive childhood variables, and age at follow-up was regressed from DIVA symptom scores to account for age effects on all these variables ($p < 0.05$). There was no effect of age on clinical impairment at follow up ($p > 0.05$), therefore this was not controlled for. To aid interpretation, correlation coefficients (r) are presented as effect sizes for the regression models (Table 5-3 and 5-4), where $r > 0.1$, $r > 0.3$ and $r > 0.5$ are considered small, medium and large effects, respectively (Cohen, 1988). For the group analyses, Cohen's d effect sizes are presented along with means, SDs and test statistics (Table 5-5), where 0.2 is considered a small effect, 0.5 considered a medium effect and 0.8 considered a large effect (Cohen, 1992).

5.4 RESULTS

5.4.1 Predictors of ADHD symptoms and impairments

Linear regressions were first conducted to determine which childhood variables are associated with DIVA ADHD symptoms (Table 5-3) and Barkley's ratings of functional impairment (Table 5-4). Parent-rated childhood inattention and hyperactivity-impulsivity symptoms, as well as co-occurring symptoms including oppositional

behavior, anxiety, emotional lability and social problems, were predictive of higher ADHD symptoms and impairment at follow up. However, the co-occurring symptoms were no longer significant predictors after controlling for ADHD symptoms in childhood (all $p > 0.05$). Teacher-rated ADHD symptoms or co-occurring symptoms in childhood did not significantly predict parent interview-based ADHD symptoms at follow up. The actigraph measure of mean intensity of movement level in childhood significantly predicted both ADHD symptoms and impairment at follow up, while variability of movement intensity only significantly predicted ADHD symptoms but not impairment, and neither mean nor variability of movement count were significant predictors of ADHD symptoms or impairment at follow up.

Higher IQ scores and higher SES in childhood were both associated with lower ADHD symptoms (Table 5-3), as well as fewer reports of clinical impairments (Table 5-4), in adolescence/early adulthood. The predictive value of childhood IQ on ADHD symptoms, after controlling for SES, remained significant for ADHD symptoms ($p = 0.05$), but was reduced to a trend level for clinical impairments ($p = 0.06$) at follow up. The predictive value of SES, after controlling for childhood IQ, reduced to a trend level for ADHD symptoms ($p = 0.08$), but remained significant for clinical impairments ($p = 0.05$). Controlling for childhood ADHD symptoms did not affect the predictive values of IQ or SES ($p < 0.05$). No other cognitive variable measured in childhood significantly predicted either ADHD symptoms or impairment at follow up (Tables 5-3 and 5-4).

A canonical correlation analysis was performed to determine (i) the relationship between the combined effects of the identified childhood predictors of interest (mean actigraph intensity, SES and IQ) and ADHD outcome (DIVA symptoms and impairment), and (ii) the relative contribution of each of these factors on this association. We did not

include parent ratings of childhood ADHD as a predictor as this measure reflects a continuation of symptoms rather than a risk factor. The two canonical correlations were 0.36 and 0.06, respectively. Only the first canonical correlation was interpreted, as it was significant (Wilks' $\Lambda = 0.87$, $F(6, 210) = 2.61$, $p = 0.02$). The canonical correlation of 0.36 indicates that the combined effect of the three selected childhood predictor (variate T1) explained 13% ($0.36^2 * 100$) of the variance in ADHD symptoms and impairment (variate T2). IQ made a significant contribution to the predictor variate (T1) ($t = 2.48$, $p = 0.02$; CI: 0.01, 0.08), while SES and mean actigraph intensity did not ($p = 0.12$, $p = 0.14$, respectively). DIVA ADHD symptoms contributed significantly to the outcome variate (T2) ($t = 2.00$, $p = 0.05$; CI: 0.02, 3.51) but only a trend was observed for functional impairment ($t = -1.77$, $p = 0.08$; CI: -0.17, 0.01)(Figure 5-1).

5.4.2 Predictors for categorical diagnosis of ADHD persistence

Logistic regressions were conducted to examine, which variables in childhood predict a clinical ADHD diagnosis in adolescence/early adulthood (Table 5-5). Inattention symptoms, social and emotional problems in childhood significantly differentiated between ADHD persisters and remitters at follow up. However, after controlling for childhood ADHD symptoms, social and emotional problems were no longer significant predictors ($p > 0.05$). SES was significantly higher in remitters than in persisters, even when childhood IQ was included as a covariate ($z = -2.47$, $p = 0.01$). None of the cognitive variables measured in childhood, including IQ, significantly predicted ADHD diagnostic status in adolescence and adulthood.

Table 5-3. Predictive values of childhood measures on interview-based ADHD symptoms in adolescence and adulthood.

	<i>r</i>	<i>r</i> ²	<i>t</i>	<i>F</i>	<i>df</i>	<i>p</i>
ADHD symptoms						
Inattention						
Parent-rated	0.45	0.20	5.32	28.27	1/113	<0.01
Teacher-rated	0.01	0.00	0.13	0.02	1/107	0.90
Hyperactivity-Impulsivity						
Parent-rated	0.43	0.18	4.97	24.72	1/112	<0.01
Teacher-rated	0.08	0.01	0.85	0.73	1/107	0.40
Activity level						
Mean intensity	0.33	0.11	2.82	7.95	1/64	<0.01
Mean count	0.15	0.02	1.24	1.53	1/64	0.22
IIV intensity	0.27	0.07	2.20	4.85	1/64	0.03
IIV count	0.03	0.00	0.24	0.06	1/64	0.81

Co-occurring symptoms						
Oppositional behaviours						
Parent-rated	0.25	0.06	2.74	7.50	1/112	<0.01
Teacher-rated	0.09	0.01	0.98	0.95	1/106	0.33
Anxious/shy behaviours						
Parent-rated	0.20	0.04	2.18	4.74	1/112	0.03
Teacher-rated	-0.07	0.01	-0.77	0.59	1/107	0.44
Social problems						
Parent-rated	0.27	0.07	2.99	8.94	1/113	<0.01
Teacher-rated	0.07	0.01	0.75	0.56	1/107	0.47
Emotional problems						
Parent-rated	0.36	0.13	3.52	12.40	1/85	<0.01
Teacher-rated	0.07	0.00	0.60	0.36	1/84	0.55
Social communication	0.23	0.05	2.53	6.38	1/113	0.01

SES	-0.20	0.04	-2.12	4.50	1/103	0.04
Cognitive performance						
IQ	-0.25	0.06	-2.78	7.71	1/111	<0.01
Digit span forward	-0.13	0.02	-1.22	1.49	1/86	0.23
Digit span backward	-0.06	0.00	-0.55	0.31	1/86	0.58
RTV	0.03	0.00	0.22	0.05	1/53	0.83
OE	0.13	0.02	1.04	1.08	1/63	0.30
CE	-0.07	0.01	-0.56	0.32	1/63	0.58
Choice impulsivity	0.15	0.02	1.25	1.56	1/65	0.22

Table 5-4. Predictive value of childhood measures on parent ratings of functional impairment in adolescence/adulthood.

	<i>r</i>	<i>r</i> ²	<i>t</i>	<i>F</i>	<i>df</i>	<i>p</i>
ADHD symptoms						
Inattention						
Parent-rated	0.37	0.14	4.28	18.29	1/113	<0.01
Teacher-rated	0.05	0.00	0.50	0.25	1/107	0.25
Hyperactivity-Impulsivity						
Parent-rated	0.33	0.11	3.75	14.03	1/112	<0.01
Teacher-rated	0.16	0.03	1.67	2.79	1/107	0.10
Activity level						
Mean intensity	0.26	0.07	2.17	4.69	1/65	0.03
Mean count	0.22	0.05	1.78	3.15	1/65	0.08
IIV intensity	0.21	0.05	1.77	3.14	1/65	0.08
IIV count	0.13	0.02	1.06	1.11	1/65	0.30

Co-occurring symptoms**Oppositional behaviours**

Parent-rated	0.31	0.10	3.47	12.05	1/112	<0.01
--------------	------	------	------	-------	-------	-----------------

Teacher-rated	0.05	0.00	0.50	0.25	1/106	0.25
---------------	------	------	------	------	-------	------

Anxious/shy behaviours

Parent-rated	0.24	0.06	2.64	6.97	1/112	0.01
--------------	------	------	------	------	-------	-------------

Teacher-rated	0.00	0.00	0.05	0.00	1/107	0.96
---------------	------	------	------	------	-------	------

Social problems

Parent-rated	0.32	0.10	3.57	12.73	1/113	<0.01
--------------	------	------	------	-------	-------	-----------------

Teacher-rated	0.09	0.01	0.88	0.38	1/107	0.78
---------------	------	------	------	------	-------	------

Emotional problems

Parent-rated	0.33	0.11	3.73	13.93	1/112	<0.01
--------------	------	------	------	-------	-------	-----------------

Teacher-rated	0.07	0.01	0.76	0.58	1/107	0.45
---------------	------	------	------	------	-------	------

Social communication	0.15	0.02	1.66	2.77	1/113	0.10
-----------------------------	------	------	------	------	-------	------

SES	-0.22	0.05	-2.32	5.38	1/103	0.02
------------	-------	------	-------	------	-------	-------------

Cognitive performance

IQ	-0.23	0.05	-2.51	6.28	1/111	0.01
Digit span forward	-0.11	0.01	-0.99	0.99	1/85	0.32
Digit span backward	-0.11	0.01	-0.98	0.96	1/85	0.33
RTV	0.03	0.00	0.25	0.06	1/54	0.81
OE	-0.03	0.00	-0.21	0.04	1/64	0.84
CE	-0.07	0.01	-0.58	0.34	1/64	0.57
Choice impulsivity	0.15	0.02	1.25	1.57	1/66	0.21

Table 5-5. Predictive value of childhood measures on ADHD status (ADHD persisters vs ADHD remitters).

	Persisters (n=87) Mean ± SD	Remitters (n=23) Mean ± SD	z	p	Cohen's d
ADHD symptoms					
Inattention					
Parent-rated	17.47 ±7.65	10.39 ±11.24	3.27	<0.01	0.75
Teacher-rated	7.64 ±11.74	7.04 ±10.06	0.23	0.82	0.05
Hyperactivity-Impulsivity					
Parent-rated	20.07 ±8.32	16.33 ±13.18	1.65	0.10	0.34
Teacher-rated	9.15 ±14.22	8.84 ±10.25	0.10	0.92	0.03
Activity level					
Mean intensity	1.47 ±0.46	1.30 ±0.42	1.40	0.16	0.39
Mean count	1.79 ±0.71	1.85 ±0.63	0.37	0.71	0.09
IIV intensity	1.69 ±0.50	1.44 ±0.65	1.54	0.12	0.43
IIV count	-1.35 ±0.76	-1.34 ±0.70	-0.09	0.93	0.01

Co-occurring symptoms					
Oppositional behaviours					
Parent-rated	15.11 ±11.44	10.08 ±13.94	1.79	0.07	0.39
Teacher-rated	6.01 ±14.17	10.57 ±13.81	-1.40	0.16	-0.33
Anxious/shy behaviours					
Parent-rated	8.14 ±15.10	3.91 ±14.47	1.24	0.22	0.29
Teacher-rated	2.94 ±11.74	1.37 ±11.57	0.59	0.56	0.13
Social problems					
Parent-rated	13.96 ±14.47	5.17 ±15.69	2.49	0.01	0.58
Teacher-rated	4.88 ±12.64	2.29 ±9.80	0.94	0.35	0.23
Emotional problems					
Parent-rated	14.54 ±12.00	8.38 ±15.10	2.05	0.04	0.45
Teacher-rated	7.12 ±14.87	10.90 ±14.39	-1.11	0.27	-0.26
Social communication	3.38 ±6.65	2.46 ±7.45	0.59	0.56	0.13

SES	3.81 ±1.01	4.41 ±0.88	-2.50	0.01	-0.63
Cognitive performance					
IQ	101.41 ±14.04	104.41 ±15.62	-0.99	0.32	-0.20
Digit span forward	8.23 ±1.93	8.62 ±2.29	-0.40	0.69	-0.18
Digit span backward	4.71 ±1.80	5.62 ±2.03	-1.57	0.12	-0.47
RTV	585.37 ±451.49	525.74 ±264.67	-0.08	0.94	0.16
OE	23.99 ±20.66	24.65 ±21.10	-0.61	0.54	-0.03
CE	106.21 ±33.20	114.44 ±43.87	-1.46	0.15	-0.21
Choice impulsivity	0.30 ±0.33	0.17 ±0.27	1.10	0.27	0.43

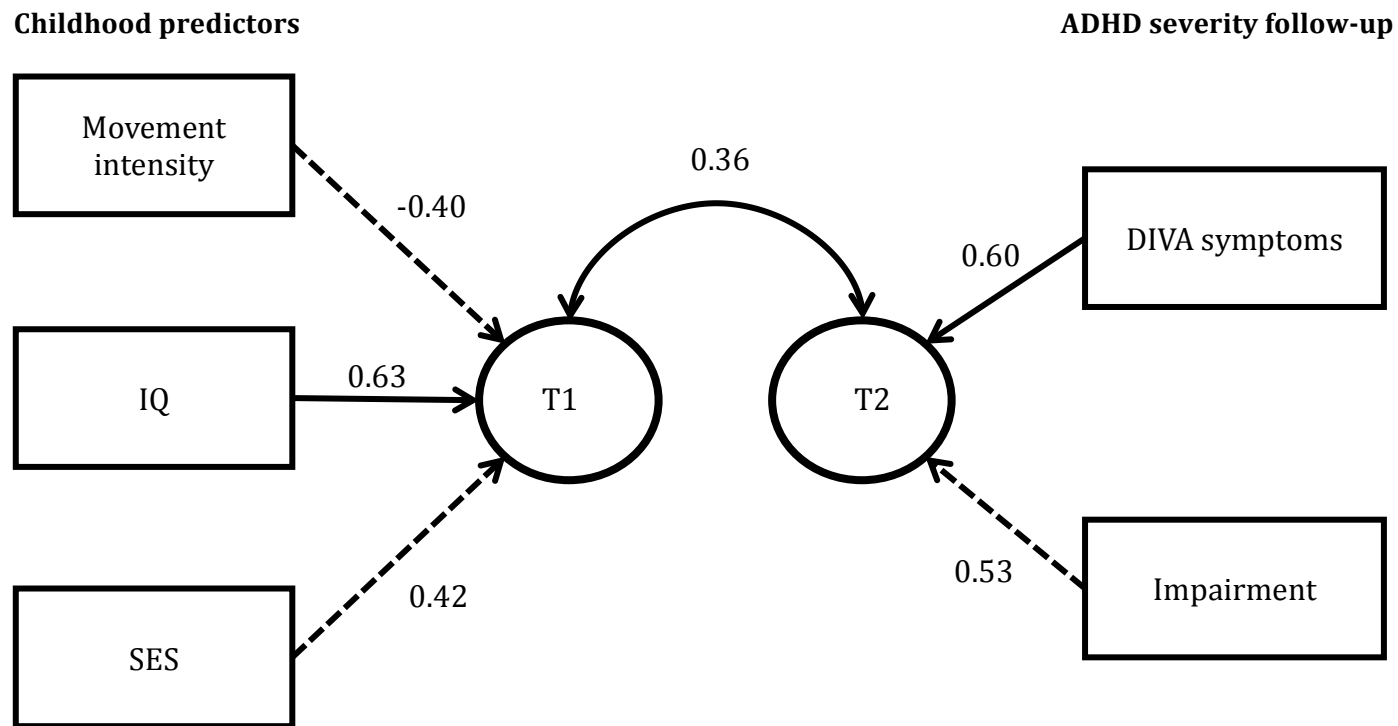

Figure 5-1. Standardised coefficients estimating the relative contribution of each variable on the canonical variates (T1/T2), where T1 reflects the linear combination of the childhood measures and T2 reflects the linear combination of the outcome measures. The relationship between the two canonical variates (T1 and T2) is represented by the canonical correlation

Significant paths ($p < 0.05$) are indicated as solid lines and non-significant paths ($p \geq 0.05$) are indicated as dotted lines

5.5 DISCUSSION

In this follow-up investigation of 110 participants with childhood ADHD, childhood variables of actigraph movement intensity, IQ and SES predicted greater ADHD symptoms and impairment in adolescence and early adulthood. Apart from IQ, none of the cognitive measures assessed in childhood predicted future ADHD symptoms or impairment, despite cross-sectional evidence of ADHD being associated with multiple cognitive impairments, such as high RTV and impaired response inhibition (Kuntsi et al. 2010). In a canonical correlation model, when IQ, SES and actigraph intensity were considered simultaneously, their combined effects were significantly associated with ADHD severity at follow up. In categorical analyses, only low SES in childhood significantly predicted the follow-up group status of ADHD-persistent. There is some suggestion of digit span backward and choice impulsivity as potential predictors of future ADHD diagnosis indicated by the effect sizes, although this was not statistically significant. The ADHD-remittent group was small (n=23), however, reflecting the high degree (79%) of ADHD persistence observed in this sample.

Our findings raise the possibility of IQ and SES as potential moderators of ADHD outcome. The association between childhood IQ and ADHD severity at follow up is consistent with previous findings that found IQ to moderate treatment outcomes in ADHD (Handen, Janosky, & McAuliffe, 1997; Owens et al., 2003). Individuals with higher IQ may develop better coping strategies to deal with their ADHD symptoms, or are more responsive to treatment. Future replication with a larger sample will be important, particularly for ADHD remittent vs persistent group comparisons. With regard to SES, while some previous studies did not find ADHD persisters to differ from remitters (Biederman et al., 2011; Biederman, Petty, Evans, Small, & Faraone, 2010; Halperin et al., 2008; Hart et al., 1995), others have either reported higher SES in ADHD remitters than

persisters (Bedard, Trampush, Newcorn, & Halperin, 2010; Halperin et al., 2008) or have shown a positive association between socio-economic advantage and treatment response (Loney et al., 1981; Molina et al., 2009). Consistent with these findings, we show that lower SES based on parental occupation alone has predictive value in ADHD outcome in adolescence and early adulthood. SES and IQ had significant independent effects on ADHD severity at follow up, but the canonical correlation analysis indicated that IQ made a larger contribution to the relationship between childhood predictors and ADHD outcome, relative to SES.

The severity of childhood ADHD symptoms, as reported by parents, was a strong predictor for ADHD outcome at follow up. The stability of ADHD symptoms was also evident from objective measures of actigraph measures of activity level. Co-occurring symptoms, such as social and emotional functioning or oppositional behaviours rated by parents, also predicted more severe symptoms and impairment at follow up. However, the predictive value of these co-occurring symptoms became trivial once childhood ADHD symptoms were controlled for, suggesting that the co-occurring problems are related to the severity of ADHD symptoms. Teacher ratings of childhood ADHD symptoms and co-occurring symptoms did not predict parent interview-based ADHD symptoms or diagnosis at follow up. This is in line with the only moderate correlations ($r=0.30$) observed cross-sectionally between parent and teacher ratings of ADHD symptoms (Newcorn et al., 1994; Wolraich et al., 2004). The reliability of teacher reports in older children or adolescents may also be compromised (Merwood et al., 2013; Sibley et al., 2012).

Some methodological limitations should be considered. The SES measure used in this study did not take into account parental education or income. Future studies should

replicate these findings with a more comprehensive measure of SES. While our study adds to previous research on predictors of ADHD persistence by including multiple domains of impairments that are most sensitive to ADHD, the exploratory approach to considering the multiple dependent measures emphasises the need for future replication of the findings. Further application and development of more complex models will also be required to test the moderating effect of IQ and SES directly in a developmental framework.

Taken together, whereas none of the cognitive measures except IQ was associated with ADHD outcome in the current sample, we demonstrate the predictive value of childhood measures of low IQ and low SES, as well as severity of ADHD symptoms as measured by parent ratings and actigraph movement intensity, on later ADHD outcome. In accordance with existing evidence from treatment studies, we show that family factors and IQ are potential moderators for the prognosis of ADHD. By identifying such predictors of later outcome, we can improve the early identification of individuals at greatest risk for poor ADHD outcome.

CHAPTER 6 - COGNITIVE AND NEUROPHYSIOLOGICAL MARKERS OF ADHD PERSISTENCE AND REMISSION

6.1. ABSTRACT

Despite the developmental persistence of attention-deficit/hyperactivity disorder (ADHD), there is a scarcity of research investigating the cognitive and neurobiological processes relating to the developmental pathways towards persistence or remission of ADHD. We carried out follow-up assessments on 110 adolescents and young adults who had childhood combined type ADHD and 169 controls, on average 6 years after initial assessments. We obtained data on actigraph measures, IQ, digit span, cognitive and ERP measures of attention (reaction time variability (RTV), omission errors (OE), cue-P3, early attentional P3), inhibition (commission errors (CE), no-go P3), response preparation (contingent negative variation, CNV), and EEG frequency power measures in the delta, theta, alpha and beta bands. ADHD persisters and controls were significantly different on all measures at follow up. Compared to ADHD persisters, remitters had significantly higher IQ, actigraph movement intensity and count, RTV, OE, delta and theta activity, and reduced CNV, but the two groups were not different in working memory (DSB) and inhibition (CE and no-go-P3 amplitudes). ADHD remitters did not differ from controls on any measures at follow up. Analyses on continuous measures of ADHD outcome indicated an association with ADHD symptoms and impairment for IQ, RTV, delta power and actigraph count and a lack of such an association for DSB, CE and no-go P3. Our results are indicative of three processes: the first encompasses preparation-vigilance-attention measures and objectively measured activity, which are no longer impaired in individuals whose ADHD symptoms improve and are markers of remission that potentially mediate ADHD outcome. The second process involves executive control processes, including inhibition and working memory, which are not sensitive to

persistence vs remittance of ADHD in either categorical or dimensional analyses. For IQ, a more complex developmental pattern emerges that is suggestive of a role in moderating ADHD outcome, as our previous analyses on the present sample found childhood IQ to predict future ADHD outcome, while other cognitive variables did not, and the present analyses indicate a higher IQ among ADHD remitters than persisters at follow up. Overall, the observed pattern of three processes would fit with previously observed aetiological separation of the cognitive impairments in ADHD into top-down executive control and proposed bottom-up arousal regulation functions. The strongest candidates for the development of non-pharmacological interventions involving cognitive training and neurofeedback are the preparation-vigilance-attention processes that were markers of ADHD remission.

6.2 INTRODUCTION

The transition from childhood to adolescence and early adulthood represents a crucial stage of developmental change. This period of development is particularly important for the study of attention-deficit/hyperactivity disorder (ADHD), a childhood onset neurodevelopmental disorder that frequently has long-term impact throughout the lifespan (National Institute of Health and Clinical Excellence (NICE), 2008). Despite the developmental persistence of ADHD in the majority of cases, around one-third of individuals no longer meet diagnostic criteria for ADHD during adolescence and appear free of clinical impairment (Biederman et al., 2000; Faraone et al., 2006a). Yet, there is a scarcity of research investigating the cognitive and neurobiological processes relating to the developmental pathways towards persistence or remission of ADHD (Loo, 2011). Identifying the mechanisms of ADHD remission may inform development of novel treatment strategies to modify the extent of clinical impairment.

A developmental model of ADHD proposed a distinction between primary, enduring deficits, linked to subcortical processes, and prefrontally mediated executive functions (EF) that can compensate for the primary impairments, determining the degree of recovery from ADHD symptoms (Halperin & Schulz, 2006; Halperin et al., 2008). While initial data were supportive of the proposed distinction between ADHD persisters and remitters on EF measures and potential measures of arousal regulation, such as reaction time variability (Halperin et al., 2008), in some subsequent studies neither executive nor non-executive domains of functioning have differentiated persisters from remitters (van Lieshout et al., 2013). A recent 5-year follow-up study found an association between improvement in EF and reduction in dimensional measures of ADHD symptoms in girls (mean age of 14.2) with ADHD (Miller et al., 2013). However, this pattern of association was not observed in another study that followed up a group of children (mean age 8) with ADHD to early adolescence (mean age of 11.5) (Vaughan et al., 2011), and studies that compared categorical groups did not find significant persistent vs remittent group differences in EF deficits (Biederman et al., 2009; Miller et al., 2012). The variability in findings across studies could be due to the heterogeneity in study design, definition of persistence and remittance, age and duration of follow up. There is also a lack of studies that include both executive and non-executive measures of cognitive processes within the same sample. The inconsistencies between studies demonstrate the need for further research with more rigorous study designs, integrating multiple levels of measurements to identify markers of ADHD persistence and recovery (Loo, 2011).

Despite the inconsistent longitudinal data, cross-sectional data on cognitive impairments and their aetiology in ADHD are consistent with the aetiological separation of cognitive impairments in ADHD. In genetic model fitting analyses on a large sample of ADHD and control sibling pairs, we previously identified two familial cognitive impairment factors

in ADHD, with the first factor capturing increased RTV and the second EF impairments, including response inhibition (Kuntsi et al., 2010). Similar analyses on a separate ADHD and control sibling pair sample also identified two familial cognitive impairment factors, with the first reflecting ‘mean and intra-individual variability of responses’, and the second EF processes, such as working memory (Frazier-Wood et al., 2012). Recent twin analyses further confirm the aetiological separation between RTV and inhibition (Kuntsi et al., 2013). In addition to the two (at least partially) separable familial cognitive impairment factors in ADHD, further largely separable aetiological influences underlie the association between ADHD and lower IQ (Rommelse et al., 2008b; Wood et al., 2010a; Wood et al., 2011).

Neurophysiological studies reveal attenuated event-related potential (ERP) activity on measures of inhibition (nogo-P3 amplitudes), preparation (contingent negative variations; CNVs) and attention orientation/allocation (cue /parietal P3 amplitudes), and performance monitoring (N2/Ne amplitudes) in both children and adults with ADHD (Albrecht et al., 2012; Dhar, Been, Minderaa, & Althaus, 2010; Doehnert et al., 2013; McLoughlin et al., 2009, 2010; McLoughlin et al., 2011). Atypical patterns of EEG oscillatory activity (increased delta, theta, alpha and reduced beta power), particularly in the frontal region, during resting EEG have also been observed in both children and adults with ADHD (Snyder & Hall, 2006), and are hypothesised to reflect cortical underactivation and reduced vigilance. However, findings for alpha and beta activity are somewhat inconsistent, as some studies have also reported reduction in alpha (Loo et al., 2009) and increased beta power in individuals with ADHD during cognitive task (Loo et al., 2011) and at rest (Clarke et al., 2002). The similarities in the neurophysiological profiles between children and adults with ADHD emphasise the sensitivity of EEG/ERP measures to the brain impairments that underlie persistence of ADHD. Apart from an

initial follow-up study of 11 ADHD and 12 control participants that highlighted CNV, as well as RTV, as developmentally stable deficits in ADHD (Doehnert et al., 2013; McLoughlin et al., 2009), data on EEG/ERP markers of persistence and remittance are as yet lacking.

The present study follows up individuals with childhood ADHD, who during childhood assessments demonstrated impairment in cognitive measures of RTV, Go/No-Go (GNG) task commission (CE) and omission (OE) errors (Andreou et al., 2007; Kuntsi et al., 2013; Kuntsi et al., 2010; Uebel et al., 2010), IQ (Wood et al., 2009b) and digit spans (chapter 3), and had a higher mean and variability of objectively-measured actigraph movement intensity and count (Wood et al., 2009b). We now aim to identify markers of underlying behavioural, cognitive and neurophysiological processes that relate to (i) an enduring deficit that continues to be impaired in those with childhood ADHD, irrespective of whether their ADHD symptoms have improved; and (ii) remission of ADHD symptoms and associated impairments during the transition from childhood to adolescence/early adulthood. In addition to cognitive performance and actigraph measures, we focus on EEG frequency bands (delta, theta, alpha and beta) and ERP measures from the cued continuous performance task (CPT-OX) (CNV, cue-P3 and nogo-P3 amplitudes), which have previously demonstrated sensitivity to ADHD (Albrecht et al., 2012; Banaschewski et al., 2003; Loo et al., 2009; McLoughlin et al., 2010; McLoughlin et al., 2011). We also include measures of early-P3 (250-450ms from stimulus onset) amplitudes from the baseline condition of a four-choice RT task, the Fast Task, as our previous analyses on the present sample showed that these measures are attenuated in persistent ADHD, indicating difficulties with attentional resource allocation (chapter 4). As well as defining ADHD outcome using a categorical diagnosis of persistence, we also examine ADHD symptoms and related impairments at follow-up as continuous traits.

6.3 METHODS

6.3.1 Sample

Participants who had taken part in our previous research (UK-London sub-sample of an international collaboration (Chen et al., 2008; Kuntsi et al., 2010)) were invited to take part in this study. ADHD probands and their siblings who had a DSM-IV diagnosis of ADHD-C during childhood, and control participants who had no previous history of ADHD were included in this study. Participants with ADHD were initially recruited from specialised ADHD clinics in the UK. Patients being treated for ADHD were assessed using the Parental Account of Childhood symptoms (PACS) (Chen et al., 2008; Taylor et al., 1986a; Taylor et al., 1986b), a semi-structured, standardised, investigator interview with high inter-rater reliability (Taylor et al., 1986a), to establish the research diagnosis of DSM-IV ADHD-C in childhood. Exclusion criteria applied at the baseline childhood assessment included IQ<70, autism, epilepsy, general learning difficulties, brain disorders and any genetic or medical disorder associated with externalising behaviours that might mimic ADHD. The control group was initially recruited from schools in the UK, aiming for an age and sex match with the clinical sample. The same exclusion criteria were applied as for the clinical sample. Participants were aged between 6 and 17 at the initial assessment.

We followed up the sample on average 5.8 years (SD = 1.1) after initial assessments. At follow up, six control participants were removed from the analyses for meeting DSM-IV ADHD criteria based on the parent-rated Barkley Informant Rating Scale (Barkley & Murphy, 2006b). A further six participants with ADHD were excluded from the group analyses, as they had missing parent ratings of clinical impairment and their current ADHD status could not be determined. Two participants with childhood ADHD who did not meet ADHD symptom criteria but met clinical levels of impairment at follow up were

further excluded, to minimize heterogeneity in the sample, as different cognitive profiles compared to the other individuals from the remitted group (Appendix C).

The final follow-up sample consisted of 279 participants, of whom 110 had a diagnosis of DSM-IV combined type ADHD in childhood (10 sibling pairs and 90 singletons) and 169 were control participants (76 sibling pairs and 17 singletons; mean age = 17.8; SD = 2.2, range 12-22). Of the ADHD group, 87 (79%) continued to meet clinical (DSM-IV) levels of ADHD symptoms and impairment (ADHD persisters; mean age= 18.3, SD=3.0, range 12-26), while 23 (21%) were below the clinical cut-off and were classified as ADHD remitters (mean age = 18.9, SD= 3.1; range 11-25). Of these 23 'remitted' individuals, 14 displayed five or more items on either the inattention or hyperactivity-impulsivity symptom domains, but did not show functional impairment (less than two domains). At follow up, the three groups did not differ in age ($F=2.05$, $df=2$, 192; $p=0.20$), but there were significantly more males in the remitted group than the other two groups ($\chi^2=7.65$, $p=0.02$) (Table 5-2).

6.3.2 Procedure

Participants were re-contacted by telephone and scheduled for a follow-up clinical interview and a cognitive-EEG assessment with simultaneous actigraph assessment at the same research centre where the initial assessment took place. The assessments of the proband and sibling were carried out in separate rooms and the order of tasks was fixed. For those prescribed stimulants ($n=52$), a 48-hour ADHD medication-free period was required prior to cognitive-EEG assessments. The total length of the test session, including breaks, was approximately 3.5-4 hours. Face-to-face or telephone clinical interviews were administered to the parent of each ADHD proband shortly before or after the participant's assessment.

6.3.3 Measures

The Diagnostic Interview for ADHD in adults (DIVA) (Kooij & Francken, 2007) is a semi-structured interview designed to evaluate the DSM-IV criteria for both adult and childhood ADHD symptoms and impairment. The DIVA was conducted by trained researchers on parent of the ADHD proband.

The Barkley's functional impairment scale (BFIS) (Barkley & Murphy, 2006b). This 10-item scale is used to assess the levels of functional impairments commonly associated with ADHD symptoms in five areas of everyday life: family/relationship; work/education; social interaction; leisure activities and management of daily responsibilities. Each item ranged from 0 (never or rarely) to 3 (very often).

Diagnostic status at follow-up. Participants were classified as 'affected' at follow-up if they scored a 'yes' on ≥ 6 items in either the inattention or hyperactivity-impulsivity domains on the DIVA, and they scored ≥ 2 on two or more areas of impairments on the BFIS.

IQ and digit span. The vocabulary and block design subtests of the Wechsler Abbreviated Scale of Intelligence Fourth Edition (WASI) (Wechsler, 1999) were administered to all participants to derive an estimate of IQ. The digit span subtest from the WISC-III (Wechsler, 1991) or the WAIS-III (Wechsler, 1997a) was administered to participants aged below 16 and aged 16 or above, respectively, to obtain digit span forward (DSF) and backward (DSB). The forward test requires the participant to verbally repeat a sequence of digits in the straightforward order, and is a measure of short-term verbal memory. The backward test requires the participant to repeat a sequence of digits in reverse order,

and is a measure of verbal working memory. The number of digits increases by one until the participant consecutively fails two trials of the same digit span length.

Actigraph measures of activity level. The actigraph readings used in the current analyses were taken during the clinical interviews and cognitive-EEG assessments. The total length of the testing session was approximately 3 hours, excluding a 30-minute unstructured break given approximately halfway through the session when actigraph measurements were not analysed. Two actigraph measures, which we previously showed to reliably distinguish between ADHD probands and controls (ROC-AUC= 0.61-0.79) (Wood et al., 2009b), were obtained from the dominant ankle of each participant: the mean intensity of movements (mean intensity), and the mean number of movements (mean count).

The cued flanker Continuous Performance Task (CPT-OX) (Doehnert, Brandeis, Straub, Steinhausen, & Drechsler, 2008; Valko et al., 2009). This task combines vigilance with cued GNG tasks, which probes attention, preparation and response inhibition or control, with incompatible flankers throughout to increase difficulty for adults. Participants are instructed to press the response button with the index finger of their dominant hand only if a central ' O ' (cue trials, n=80) was followed by a central ' X ' (target trials, n=40), but to withhold responding if the cue was followed by a non-target (no-go trials, n=40), or if the ' X ' was not preceded by a cue (n=40). Most trials were neutral distractors (letters B, C, D, E, F, G, J or L, n=20 each, or the letter H, n=80) which also did not require a response, making up a total of 400 trials presented at a rate of 1/1650 ms. The sequences and neutral distractors were pseudo-randomly distributed.

The flankers consisted either of O's or X's to induce conflict. Targets and distractors H

were flanked by O's ('OXO' and 'OHO'), while cues as well as the remaining distractor stimuli were flanked by X's. As a consequence, cues and cued distractors required additional response control in terms of inhibition (as they are flanked by target stimuli which can require a response in the context of the CPT paradigm). Cued targets require additional response control in terms of execution (since the flanking cue stimuli would require no response). Cognitive performance measures of RTV, CE, OE; EEG measures of delta, theta, alpha and beta power; and ERP amplitude measures of CNV, cue-P3 and nogo-P3 were obtained from this task.

The Fast Task (Andreou et al., 2007; Kuntsi et al., 2006b). The baseline condition consists of 72 trials, which followed a standard warned four-choice RT task. Four empty circles (warning signals, arranged horizontally) first appeared for 8s, after which one of them (the target) was coloured in. Participants were asked to press the response key that directly corresponded to the position of the target stimulus. Following a response, the stimuli disappeared from the screen and a fixed inter-trial interval of 2.5s followed. Speed and accuracy were emphasised equally. If the participant did not respond within 10s, the trial terminated. A comparison condition with a fast event rate (1s) and incentives followed the baseline condition (Andreou et al., 2007). Cognitive measure of RTV and ERP markers of early-P3 amplitudes (adjusted and unadjusted for prestimulus ERP activity; chapter 4) were obtained. Only measures from the baseline condition were included in this analysis, as this condition is more sensitive to ADHD (Kuntsi et al., 2012).

6.3.4 EEG recording and processing

The EEG was recorded from 62 channels DC-coupled recording system (extended 10–20 montage), with a 500Hz sampling-rate, impedances kept under 10k Ω , and FCz as the reference electrode. The electro-oculograms (EOGs) were recorded from electrodes

above and below the left eye and at the outer canthi.

The EEG data were analysed using Brain Vision Analyzer (2.0) (Brain Products, Germany). After down-sampling the data to 256 Hz, the EEG data were re-referenced to the average and filtered offline with digitally band-pass (0.1 to 30 Hz, 24 dB/oct) Butterworth filters. Ocular artifacts were identified from the data using Independent Component Analysis (ICA) (Jung et al., 2000). The extracted independent components were manually inspected and ocular artefacts were removed by back-projection of all but those components. Data with other artifacts exceeding $\pm 100\mu\text{V}$ in any channel were rejected. No baseline subtraction was applied to be consistent with previous ERP analyses on this task (McLoughlin et al., 2010; 2011; Albert et al., 2012; Doehnert et al., 2011, 2012). For the Fast Task, P3 analysis was performed both with and without prestimulus (-200-0ms) baseline subtraction, following the methodology from chapter 4, as an empirical approach was considered most appropriate for this novel task for which the topographies of the ERP components have not been previously established. All averages contained at least 20 sweeps.

6.3.5 ERP analyses

CPT-OX

The contingent negative variations (CNVs) were analysed as mean amplitudes between 1300 and 1650 ms following cues over the central electrode (Cz). The cue-P3 had a parietal maximum (Figure 6-1a) and was defined as the most positive peak between 250 and 600 ms following cue trials at electrode Pz. The nogo-P3 was defined as the most positive peak between 250 and 600ms following no-go trials at electrode Cz.

Fast Task

The parietal early-P3 was analysed as the area amplitude measure ($\mu\text{V} * \text{ms}$) between 250 and 450 ms following target trials at electrode Pz. We analysed both the unadjusted and adjusted early-P3 amplitude (without and with prestimulus (-200-0ms) ERP activity subtraction, respectively; chapter 4).

6.3.6 EEG frequency analyses

We estimated the mean EEG power (μV^2) in the delta (0.5-3 Hz), theta (4–7 Hz), alpha (7–12 Hz) and beta (12–30 Hz) bands (Tye et al., 2011) using the Fast Fourier Transform (FFT). To reduce the number of statistical comparisons, we analysed the frontal location only, which has consistently been reported as sensitive to ADHD impairment, by computing the mean activity of electrodes (F1-F8, Fz) in the CPT. As the Fast Task has not yet been used in EEG/ERP studies previously, we only analysed these measures from the CPT. However, the patterns of group mean differences on EEG frequency band power between the ADHD persisters, ADHD remitters and controls of the Fast task are similar to those found in the CPT (Appendix D-F).

6.3.7 Statistical analyses

We ran regression models with dummy variables to identify which measures showed an overall effect of group (ADHD persisters vs ADHD remitters vs controls), with controls as the reference group. The main model also provided the test statistics for group comparisons against the reference group (i.e. ADHD persisters vs controls and ADHD remitters vs controls). On measures that indicated differences between ADHD persisters and controls, post-hoc *t*-tests were conducted to examine the differences between ADHD persisters and remitters on these measures. As all three groups were matched on age at follow up, this variable was not included as a covariate. Although there were significantly

more males in the ADHD-remittent group compared to the other two groups, we did not covary for gender in the group analyses to avoid controlling for ADHD severity; as female gender was associated with higher parent-ratings of impairment ($\chi^2= 3.75$, $p=0.05$). Instead, we explored the effect of gender by re-running all analyses with the females ($n=15$) removed; the pattern of results remained the same. For IQ we examined any potential effects empirically. We first performed the group comparisons without controlling for IQ and subsequently re-ran the analysis covarying for the effects of IQ. The dependence of the variables investigated in this study meant that it was inappropriate to perform standard multiple testing procedures, which assume independence of the data. Therefore we did not adjust for multiple testing and accepted p-values of ≤ 0.05 as significant. However, we emphasise on effect sizes of group differences in addition to significance levels. Cohen's *d* effect sizes are presented along with means, SDs and test statistics for the group analyses (Table 6-1), where 0.2 is considered a small effect, 0.5 a medium effect and 0.8 a large effect (Cohen, 1992).

Pearson correlations were also conducted on these measures to examine their associations with DIVA ADHD symptom scores, and clinical impairment within those who had a childhood ADHD diagnosis. Age and gender were included as covariates, as age showed significant associations with ADHD symptoms ($r= -0.22$, $p=0.02$) and females had significantly more clinical impairment than males. To examine the potential effects of IQ on these associations, we re-ran the correlations with IQ included as a covariate.

All cognitive measures and EEG frequency measures were skewed and log-transformed to normal in STATA version 10 (StataCorp, College Station, TX). We also controlled for genetic relatedness of the sibling pairs using the 'robust cluster' command in STATA (Tye et al., 2012; Wood et al., 2009b).

6.4 RESULTS

When not controlling for IQ, the main effect of group (ADHD persisters vs ADHD remitters vs control) was significant for all measures investigated, except for beta activity, and adjusted and unadjusted early-P3 (Table 6-1). With IQ as a covariate, the main effect of group was no longer significant for alpha activity, while beta activity and unadjusted early-P3 amplitude became significant when IQ was controlled for (both $p < 0.05$). The main effect of group was unaffected by IQ on all the other measures.

6.4.1 Which measures show ADHD-control differences at follow-up?

ADHD-persistent and control group differences were observed on all measures except for adjusted early-P3, for which the group difference emerged as significant when IQ was controlled for ($p = 0.05$) (Table 6-1). For delta, theta, alpha and beta activity, as well as DSF, the ADHD persistent vs control group difference was no longer significant, when IQ was included as a covariate (all $p > 0.05$).

The effect sizes, when not controlling for IQ, indicate that RTV (Fast Task), IQ, OE and actigraph mean count discriminated between ADHD-persistent and controls with a large effect size ($d' = 0.87-1.23$) (Table 6-1). Medium effect sizes ($d' = 0.54-0.71$) were observed for actigraph mean intensity, RTV from (CPT-OX), digit spans (forward and backward), CE, nogo-P3 and CNV (Table 6-1). Other ERP and EEG measures, including cue-P3, delta, theta, alpha and beta activity had small effect sizes ($d' = 0.20-0.44$) (Table 6-1). Controlling for IQ led to some reduction in effect sizes for most variables (Table 6-1); effect size was large now only for RTV from Fast Task.

6.4.2 Which processes are markers of recovery that distinguish between ADHD persisters and remitters?

ADHD remitters were significantly different from ADHD persisters, and not significantly different from controls, on measures of IQ, RTV, OE, CNV, delta and theta activity, actigraph intensity and count (Table 6-1). In addition, for cue-P3 amplitudes we observed a similar but non-significant pattern of findings: ADHD remitters were not significantly different from controls (d' close to zero) (Table 6-1 and Figure 6-1b), and both the comparisons between the ADHD-persistent vs ADHD-remittent and between ADHD-persistent vs controls were of medium effect sizes ($d'=0.20$ and 0.50), although the former was not significant ($p=0.18$).

As ADHD persisters had a lower IQ than ADHD remitters (Table 6-1), we re-ran the analyses whilst controlling for effects of IQ for all variables. The group differences between ADHD persisters and remitters remained significant for RTV ($p=0.03$), OE, actigraph intensity and count (all $p<0.01$), but controlling for IQ diminished the group effects for CNV amplitude, delta and theta power which were no longer significant (Table 6-1). The ADHD persistent vs control difference became significant for adjusted early-P3 (with prestimulus activity subtraction), with the effect sizes showing a trend for the remission pattern. The effect sizes remained similar for alpha power and cue-P3 amplitude when controlling for IQ.

6.4.3 Which processes are enduring deficits that continue to be impaired in those with childhood ADHD diagnosis, irrespective of current ADHD status?

The full requirement for an enduring deficit would be a significant ADHD-remittent vs control group difference but no ADHD-persister vs ADHD-remittent group difference.

Here, although ADHD remitters were not significantly different from ADHD persisters on several of the measures, none of the measures showed significant differences between the ADHD remitters and controls (Table 6-1). Therefore, none of the processes investigated in this study fulfilled the strict criteria for enduring deficits, when using categorical diagnoses.

However, several variables did not differ significantly between ADHD persisters and remitters, and the effect size for the ADHD remittent vs control comparison was comparable to the effect size of the ADHD persistent-remittent comparison (around 0.30). Such a pattern, where the ADHD remitters are in the middle, in between the other two groups, was observed for DSB, CE, nogo-P3 (Figure 6-2) and unadjusted early-P3 amplitudes (Figure 6-3a). With IQ as a covariate, the pattern remained unchanged for CE and nogo-P3 amplitudes, although the effect size for the ADHD persistent-remittent comparison on DSB reduced from 0.31 to 0.08 (Table 6-1).

6.4.4 Which processes are associated with continuous trait measures of ADHD symptoms and clinical impairment at follow up within those who had a childhood ADHD diagnosis?

ADHD symptoms and impairment at follow up correlated significantly with IQ, RTV (from both tasks), OE, delta activity and actigraph count. Adjusted and unadjusted early-P3 were both associated with ADHD symptoms only, while actigraph intensity was associated only with impairment (Table 6-2). No other significant associations were observed. When we re-ran the analysis with IQ as a covariate in addition to gender and age, RTV from the CPT-OX was no longer significantly associated with impairment, and OE and delta were no longer associated with ADHD symptoms (Table 6-3).

All the other correlations remained significant. Of the variables on which ADHD remitters were in-between ADHD persisters and controls, the expected lack of association with ADHD symptoms was observed for no-go P3 amplitudes, CE and DSB, with correlations non-significant and low at -0.01 to -0.12.

Table 6-1. Group comparison on IQ, digit span, cognitive performance, ERP, EEG and actigraph measures.

Cohen effect sizes (d') are presented without and with IQ included as a covariate

	ADHD persisters (n = 87)	ADHD remitters (n = 23)	Controls (n = 169)	<i>F</i>	<i>df</i>	<i>p</i>	<i>Cohen d'</i>	<i>Cohen d' (IQ controlled)</i>
<i>Cognitive measures</i>								
Total IQ	96.20 (15.33)	104.57 (13.63)	109.98 (12.42)	22.35	2, 192	<0.01	a = -0.99** b = -0.58* c = -0.41	
Digit span Forward	9.29 (2.01)	10.04 (2.18)	10.44 (2.14)	7.40	2, 192	<0.01	a = -0.55** b = -0.36 c = -0.19	a = -0.23 b = -0.14 c = -0.04
Digit span Backward	6.22 (2.38)	6.96 (2.46)	7.99 (2.64)	13.01	2, 192	<0.01	a = -0.70** b = -0.31 c = -0.40	a = -0.34* b = -0.08 c = -0.21
RTV (CPT)	110.47 (56.35)	79.52 (50.70)	78.87 (36.76)	10.86	2, 192	<0.01	a = 0.68** b = 0.55** c = -0.08	a = 0.48** b = 0.44* c = -0.09
RTV (Fast Task)	182.32 (129.20)	122.98 (77.00)	102.10 (82.82)	31.57	2, 190	<0.01	a = 1.23** b = 0.62** c = 0.29	a = 0.83** b = 0.44* c = 0.19

CE	2.12 (2.60)	1.43 (2.02)	0.87 (1.33)	10.28	2, 191	<0.01	a = 0.69** b = 0.28 c = 0.24	a = 0.47** b = 0.17 c = 0.19
OE	2.76 (4.07)	0.79 (1.36)	0.59 (1.00)	18.88	2, 191	<0.01	a = 0.93** b = 0.77** c = 0.10	a = 0.63** b = 0.59** c = 0.04

ERPs

CNV	-2.90 (2.02)	-3.73 (1.75)	-3.85 (1.85)	6.52	2, 190	<0.01	a = 0.54** b = 0.42* c = 0.07	a = 0.45** b = 0.39 c = 0.05
Cue P3	5.46 (2.58)	6.31 (2.76)	6.38 (2.45)	3.68	2, 190	0.03	a = -0.37** b = -0.27 c = -0.02	a = -0.39** b = -0.30 c = -0.05
No Go P3	6.68 (4.60)	7.80 (4.12)	9.10 (3.90)	8.09	2, 188	<0.01	a = -0.61** b = -0.22 c = -0.27	a = -0.57** b = -0.23 c = -0.27
Unadjusted Early-P3	971.84 (522.85)	982.02 (312.05)	1154.13 (579.72)	2.64	2, 184	0.07	a = -0.35* b = -0.17 c = -0.23	a = -0.45** b = -0.18 c = -0.29
Adjusted P3	1079.33 (482.63)	1145.06 (328.13)	1191.01 (557.05)	1.03	2, 184	0.36	a = -0.20 b = -0.25 c = 0.02	a = -0.33* b = -0.26 c = -0.06

EEG frequency bands								
Delta	6.04 (3.89)	4.45 (2.26)	4.67 (2.37)	4.84	2, 189	<0.01	a = 0.44** b = 0.45* c = -0.11	a = 0.18 b = 0.35 c = -0.18
Theta	1.13 (0.86)	0.79 (0.36)	0.90 (0.63)	3.89	2, 189	0.02	a = 0.35* b = 0.50* c = -0.14	a = 0.12 b = 0.36 c = -0.20
Alpha	0.91 (0.78)	0.71 (0.44)	0.67 (0.48)	3.28	2, 189	0.04	a = 0.39* b = 0.22 c = 0.14	a = 0.29 b = 0.17 c = 0.13
Beta	0.24 (0.19)	0.22 (0.17)	0.20 (0.14)	2.36	2, 189	0.10	a = 0.33* b = 0.15 c = 0.08	a = 0.18 b = 0.13 c = 0.04
Actigraph movement								
Mean intensity	1.21 (0.74)	0.77 (0.47)	0.78 (0.55)	10.77	2, 169	<0.01	a = 0.71** b = 0.60** c = 0.04	a = 0.59** b = 0.53* c = 0.00
Mean count	0.05 (0.04)	0.02 (0.01)	0.03 (0.06)	13.77	2, 143	<0.01	a = 0.87** b = 0.80** c = 0.01	a = 0.59** b = 0.70* c = -0.03

** p<0.01, * p<0.05, ^aADHD persisters vs controls; ^b ADHD persisters vs ADHD remitters; ^c ADHD remitters vs controls

RTV, reaction time variability; CE, commission errors; OE, omission errors; CNV, continuous negative variation

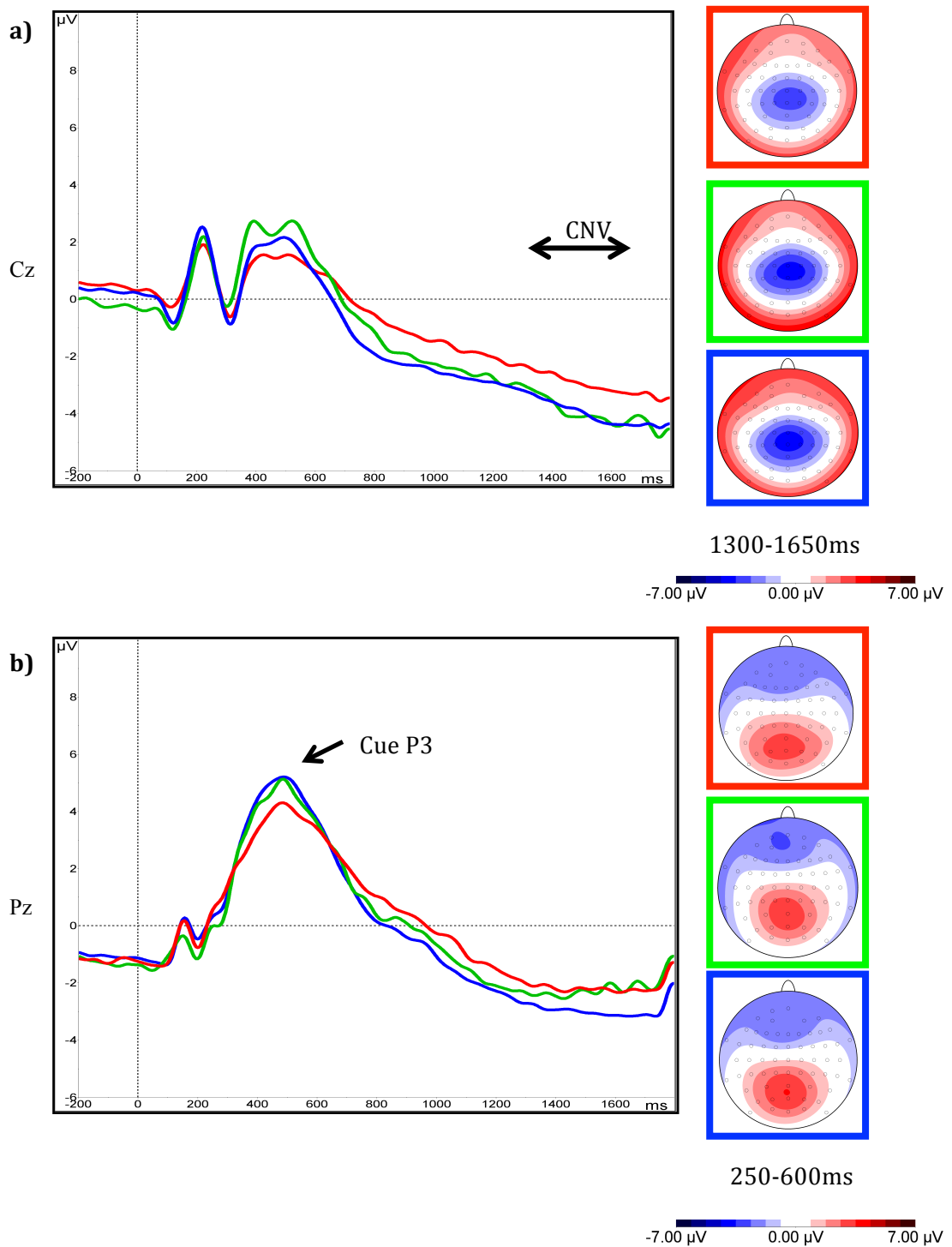

Figure 6-1. Waveform ERPs and topographical maps for (a) CNV at central electrode (Cz), and (b) cue-P3 amplitudes at parietal electrode (Pz) in ADHD persisters (red), ADHD remitters (green) and controls (blue)

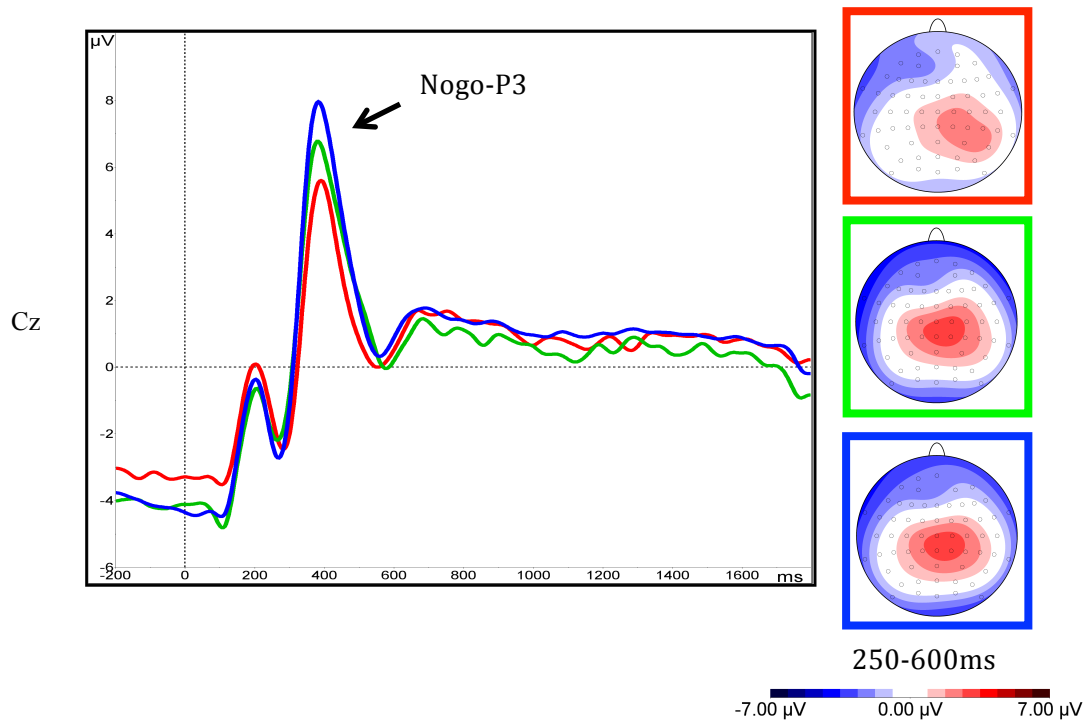

Figure 6-2. Waveform ERPs and topographical maps for nogo-P3 at central electrode (Cz) in ADHD persisters (red), ADHD remitters (green) and controls (blue)

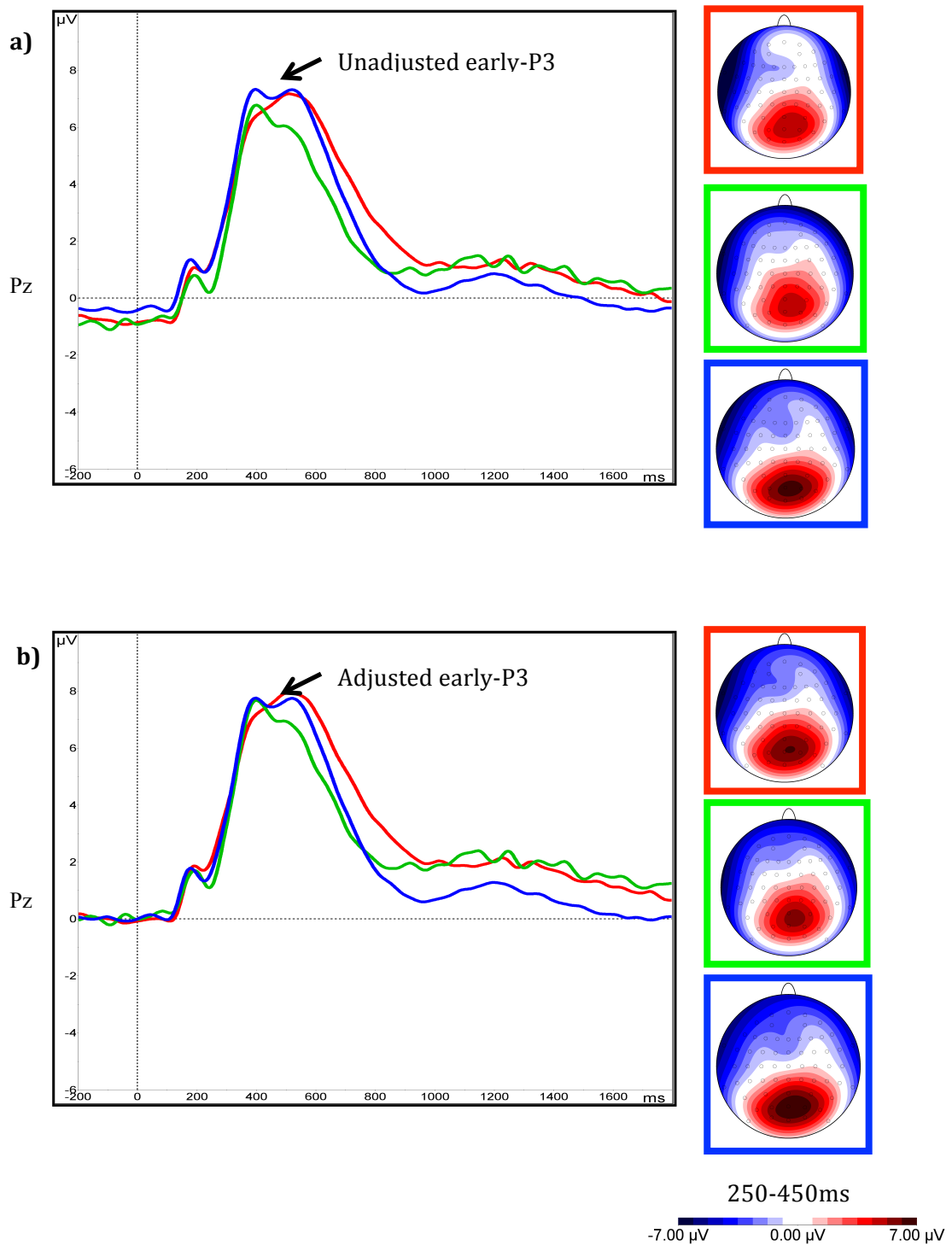

Figure 6-3. Waveform ERPs and topographical maps for (a) unadjusted early-P3 and (b) adjusted early-P3 amplitudes at parietal electrode (Pz) in ADHD persisters (red), ADHD remitters (green) and controls (blue)

Table 6-2. Pearson correlations (two-tailed) of IQ, digit span, cognitive performance, ERP, EEG and actigraph measures with interview-based DIVA ADHD symptoms and clinical impairment within the ADHD group only (n=110), without controlling for IQ

	ADHD symptoms		Impairment	
	<i>r</i>	<i>p</i>	<i>r</i>	<i>p</i>
Total IQ	-0.26	<0.01	-0.27	<0.01
Digit span forward	-0.07	0.50	-0.11	0.24
Digit span backward	-0.12	0.20	-0.13	0.19
RTV (CPT)	0.25	<0.01	0.19	0.05
RTV (Fast-task)	0.26	0.01	0.26	<0.01
CE	-0.01	0.99	0.17	0.08
OE	0.19	0.05	0.27	<0.01
CNV	0.03	0.80	0.12	0.24
Cue P3	-0.10	0.36	-0.12	0.23
No Go P3	-0.07	0.48	-0.04	0.72
Unadjusted early-P3	-0.24	0.02	-0.02	0.85
Adjusted early-P3	-0.29	<0.01	-0.18	0.08
Delta	0.21	0.04	0.27	0.01
Theta	0.08	0.43	0.07	0.46
Alpha	0.06	0.56	0.07	0.45
Beta	-0.06	0.53	0.09	0.37
Movement intensity	0.20	0.07	0.23	0.03
Movement count	0.33	<0.01	0.36	<0.01

Table 6-3. Pearson correlations (two-tailed) of digit span, cognitive performance, ERP, EEG and actigraph measures with interview-based DIVA ADHD symptoms and clinical impairment within the ADHD group only (n=110), controlling for IQ

	ADHD symptoms		Impairment	
	<i>r</i>	<i>p</i>	<i>r</i>	<i>p</i>
Digit span forward	-0.00	0.97	-0.03	0.78
Digit span backward	-0.01	0.92	-0.02	0.84
RTV (CPT)	0.20	0.04	0.13	0.20
RTV (Fast-task)	0.22	0.03	0.21	0.03
CE	-0.08	0.41	0.10	0.28
OE	0.12	0.22	0.21	0.03
CNV	-0.00	1.00	0.10	0.33
Cue P3	-0.08	0.43	-0.11	0.25
No Go P3	-0.12	0.22	-0.04	0.67
Unadjusted early-P3	-0.22	0.03	0.00	0.98
Adjusted early-P3	-0.27	<0.01	-0.08	0.42
Delta	0.17	0.10	0.23	0.02
Theta	0.04	0.67	0.04	0.70
Alpha	-0.07	0.48	0.09	0.37
Beta	0.06	0.52	0.12	0.21
Movement intensity	0.18	0.10	0.21	0.05
Movement count	0.32	<0.01	0.35	<0.01

6.5. DISCUSSION

This follow-up study of 110 adolescents and young adults with childhood DSM-IV combined type ADHD and 169 non-ADHD comparisons identified three processes that predict the outcome of ADHD. The first process encompasses preparation-vigilance-attention measures (OE, RTV, CNV, delta and theta activity, and a trend for cue-P3 amplitude and alpha activity), as well as objectively-measured physical activity (actigraph intensity and count), which are no longer impaired in individuals whose ADHD symptoms improve and represent markers of remission. As these processes are associated with improvement in ADHD, they may also potentially mediate ADHD outcome. However, further investigation using measures from both assessments are required to validate this possibility. The second process involves executive control processes of inhibition and working memory (commission errors (CE), nogo-P3 and digit span backward), and attentional resource allocation (early-P3), on which ADHD remitters lie intermediate between ADHD persisters and controls and were not significantly different from either group. These markers of executive control were not associated with follow-up ADHD symptoms or impairment.

IQ represents a third process, as a potential moderator of ADHD outcome. We previously found childhood IQ to predict future ADHD outcome in the present sample, while other cognitive variables, such as RTV and CE, did not (chapter 5). In the current analyses we further demonstrate that ADHD remitters have a higher IQ than ADHD persisters at follow up. Aetiological influences on ADHD and IQ have also been shown to largely separate from those on the other cognitive impairments in ADHD (Rommelse et al., 2008b; Wood et al., 2010a; Wood et al., 2011). The possibility that IQ is a moderator rather than a mediator of ADHD outcome is also consistent with findings from longitudinal treatment studies, which report positive associations between childhood IQ

in ADHD and treatment response (Handen et al., 1997; Owens et al., 2003). Overall, the convergent findings emphasise the role of IQ in the developmental course of ADHD, and demonstrate the potential risk of poor outcome in children with concurrent ADHD symptoms and low IQ. In the present analyses IQ differences between the groups accounted also for some of the observed group differences on verbal short-term memory (digit span forward) and EEG activity across the frequency bands.

With regard to the first two processes, although our results are largely consistent with the previously observed separation of ADHD-related impairments into executive function vs preparation-vigilance processes (Johnson et al., 2007a; Johnson et al., 2007b; Kuntsi et al., 2010; O'Connell et al., 2008; O'Connell et al., 2009a) – in line with the potential top-down cognitive control vs bottom-up arousal regulation distinction (Halperin & Schulz, 2006; Halperin et al., 2008) – the way in which the two sets of impairments map onto markers of ADHD persistence and remittance is opposite to the pattern predicted based on the previous developmental model (Halperin & Schulz, 2006; Halperin et al., 2008). Our data suggest that the preparation-vigilance-attention markers, rather than executive control processes, are markers of remission in ADHD. Previous observations of ADHD-sensitive improvement in RTV but not in inhibitory deficits following incentives (Banaschewski et al., 2012; Kuntsi et al., 2009; Uebel et al., 2010) are also consistent with our findings that relative to executive control processes such as inhibition, RTV and related measures may reflect a more malleable process and show a stronger association with the improvement of ADHD symptoms. An important direction for future research will be to link the cognitive and EEG markers of remission and persistence to the three interdependent but partially separate neural networks identified in fMRI studies on ADHD, which include the frontal-parietal network, the default-mode network and the ventral-attentional network (Castellanos & Proal, 2012; Cortese et al., 2012).

Our further analyses on continuous measures of ADHD outcome confirmed the association of IQ, RTV, OE, delta and actigraph movement count with both ADHD symptoms and impairment at follow up, and the lack of such an association for digit span backward, CE and nogo-P3 amplitudes. Exceptions to the pattern expected based on group comparisons were obtained for theta activity, CNV and early-P3 (unadjusted for preparatory activity). The early-P3 amplitudes from the Fast Task, reflecting attentional resource allocation, showed a unique pattern of an association with ADHD symptoms but not impairment. OE showed a trend in the opposite direction: a strong association with impairment, but an association with ADHD symptoms that was only just significant ($p=0.05$), becoming non-significant when IQ was controlled for. Overall, findings for OE in relation to the underlying process that it captures are less consistent than for other cognitive performance variables: while the present data on OE merging with RTV rather than CE is consistent with previous studies on the arousal-attention model (Johnson et al., 2007a; Johnson et al., 2007b). In our two-factor familial model OE merged with CE at the familial level, although at the level of individual-specific environmental influences OE loaded both onto the 'RTV' and 'CE' factors (Kuntsi et al., 2010).

It is worth noting that a prestimulus baseline difference is observed between the ADHD persistent and the other two groups for the nogo-P3 amplitude (Figure 6-2). This baseline ERP difference reflects an attenuated CNV in the ADHD persistent group, and cannot account for group difference in the nogo-P3 amplitude, as it is in the opposite direction. No baseline correction was applied in this analysis, in line with previous studies on this task (McLoughlin et al., 2010, 2011; Albrecht et al., 2010; 2012; Doehnert, 2013), and as the nogo-P3 component resolves with the visual evoked response resulting in an artificial and sustained difference following the nogo-P3, it would be inappropriate to subtract the prestimulus baseline in this case (Figure 6-2).

A limitation of this study is that the sample covers only adolescence and young adults, where some younger individuals are still undergoing fundamental changes in brain development. Although, importantly, our study groups were matched for age, it would be informative to examine the hypotheses again in future follow-up assessments when all participants have reached adulthood. The high rate of ADHD persistence that we observed (79%) resulted in a modestly sized ADHD remittent group; yet, overall, the total sample size of 110 participants with childhood ADHD and 169 control participants, followed up over a 6-year period, makes the present study one of the largest cognitive or EEG follow-up studies in adolescents and adults with ADHD to date. In addition – and as diagnostic cut-offs are unavoidably arbitrary for ADHD (Chen et al., 2008) – we examined ADHD outcome also as continuous traits of ADHD symptoms and impairment. The associations with ADHD improvement observed for the preparatory-vigilance-attention measures and IQ emphasise the need for future application and development of further modeling techniques to examine the moderator and mediator effects of these measures directly within the developmental context.

Overall, our findings and evidence from earlier research raise the possibility that cognitive impairments in ADHD reflect (at least) three processes: markers of recovery, potential moderators of ADHD outcome and processes that are not significantly associated with ADHD outcome in adolescence and early adulthood (ADHD remitters in-between persisters and controls). While these possibilities await rigorous testing in future studies, the pattern would fit with the aetiological separation of the cognitive impairments in ADHD into three groups (Frazier-Wood et al., 2012; Kuntsi et al., 2010), and raises intriguing questions on possible links to the neuroimaging networks identified in ADHD (Castellanos & Proal, 2012; Cortese et al., 2012). For both researchers and clinicians, the evidence highlights the importance of a developmental approach to ADHD.

Based on these data, the strongest candidates for the development of non-pharmacological interventions involving cognitive training and neurofeedback are the preparation-vigilance-attention processes that we identified as markers of ADHD remission.

CHAPTER 7 – GENERAL DISCUSSION AND CONCLUSIONS

7.1 ABSTRACT

This concluding chapter first summarises the key findings and implications from each study of the thesis. Linking the findings from both parts of the thesis, we consider the ‘bigger picture’ and its wider implications for attention/deficit-hyperactivity disorder (ADHD). We then highlight the specific strengths and limitations of our studies, which is followed by suggested future directions to extend current understanding. The thesis ends with a final conclusion.

7.2 AIMS OF THIS THESIS

The first part of the thesis focused on children from both general and clinical population, using the quantitative genetic approach to investigate the aetiological relations between ADHD, reading disability and cognitive impairments associated with both disorders. Specifically, we aimed to quantify the extent to which the covariation between ADHD and reading difficulties (RD) was due to genetic/familial influences that were also shared with IQ and other specific cognitive processes that have previously been shown to be associated with ADHD.

The second part of the thesis examined the behavioural characteristics, cognitive and neurophysiological markers of ADHD in relation to the developmental transition between childhood and adolescence/early adulthood. Specifically, we aimed to i) investigate the neurophysiological basis of increased reaction time variability (RTV) and its improvement in ADHD; ii) identify which factors in childhood predicted ADHD diagnosis and severity in adolescence and early adulthood; and iii) examine the markers of ADHD persistence and remittance by integrating cognitive and electrophysiological measurements.

7.3 SUMMARY OF KEY FINDINGS

7.3.1 Aetiological covariation between ADHD, reading difficulties and IQ

Using a general population sample of twins, a previous study indicated that the co-occurrence between parent and teacher-rated ADHD inattention symptoms and parent-rated RD was due largely to genetic influences that were not shared with IQ (Paloyelis et al., 2010). The first study of the thesis (chapter 2) sought to replicate and extend this finding with a clinical sample of ADHD and control sibling pairs, using both parent rating scales and objective measurement of reading abilities (TOWRE). Both parent ratings and objective measures of RD yielded similar results, indicating that around half (48-62%) of the familial influences between ADHD and RD were shared, over half (54 and 78%) of which were further independent of the familial influences underlying IQ. Overall, we show that the co-occurrence between the two disorders was due partly to common aetiology, and largely independent of IQ influences. The similarities between these findings and those from the general population twin study demonstrate the generalisability of these findings to both clinical and population-based samples, and provide further support for studying ADHD using both categorical and dimensional approaches.

7.3.2 Shared cognitive impairments and aetiology in inattention and reading

Following on from the first empirical chapter, we further examined the aetiology of ADHD and RD in relation to other cognitive measures that are associated with ADHD. This issue was previously explored by one study, which found that processing speed - measured by efficiency in rapidly copying symbols, identifying target letters or pictures - captured the majority of genetic variances shared between ADHD and RD (Willcutt et al., 2010). We extended this initial study by including measures of other cognitive processes that have previously been shown to be associated with ADHD such as RTV, short-term

memory (STM) and choice impulsivity (CI), and by quantifying the degree of genetic overlap between ADHD, RD and these cognitive processes. In chapter 3, we performed multivariate structural equation modelling on a general population sample of twins aged between 7 and 10 years, to examine the relationship between ADHD symptoms of inattention and hyperactivity-impulsivity, RD and cognitive measures of response inhibition, RTV, verbal STM, working memory (WM) and CI.

We identified three cognitive processes that showed significant phenotypic and genetic associations with inattention symptoms and RD: RTV, verbal STM and WM. The proportion of shared genetic influences with inattention was 28% for RD, 21% for WM and 11% for STM. However, the majority of the genetic influences were unaccounted for in each case. Some cognitive processes were unique to ADHD symptoms (e.g. commission errors (CE) and CI) and some were only associated with inattention but not with hyperactivity-impulsivity symptoms (verbal STM and WM). RTV was not associated with STM on a phenotypic level, and showed a low but significant ($r=0.14$) association with WM. However, no significant genetic associations were observed between RTV and WM. Taken together, we obtained some evidence for shared aetiology between ADHD inattention symptoms, RD and specific cognitive processes, with RTV as the most promising candidate. However, the majority of the genetic influences on inattention and RD were not captured by the cognitive measures included in this study. The lack of phenotypic associations between CE and RD, and the lack of genetic overlap between RTV and verbal memory provides support for the aetiological distinction between RTV and executive functions.

7.3.3 Neurophysiological pathway of reduced attention fluctuation in ADHD

Following up a group of children with combined-type ADHD diagnosis and controls after approximately 6 years, we examined whether adolescents and adults with ADHD continued to show increased and greater-than-expected improvement in RTV compared to controls, and if so, what is the neurophysiological basis underlying this increase and ADHD-sensitive improvement. Using the temporal precision that EEG offers, we showed that faster event-rate and incentives normalised early-P3 amplitudes and significantly improved RTV in ADHD. ‘Adjusted’ early-P3 amplitudes (with prestimulus ERP subtraction) - as an index for attentional alerting - was associated with both increased RTV and its improvement in ADHD. Our finding also suggests that participants with ADHD recruited an alternative neurophysiological pathway to improved RTV, which was mediated by increased attentional alerting, while control participants improved RTV by adjusting their preparatory neural activity.

Our results of greater-than-expected improvement in ADHD indicate that both RTV and early-P3 amplitudes are malleable impairments associated with ADHD, and are potential targets for the development of non-pharmacological interventions. The inability to adjust the preparatory state (prestimulus ERP activity) in a changed context in ADHD may explain why RTV did not fully normalise in ADHD, and suggests that ERP markers of neural preparation (e.g. prestimulus ERP activity or contingent negative variation (CNV) activity) may be less malleable than RTV and early-P3 amplitudes. As limited research to date has investigated the effect of stimulant or task manipulation on prestimulus ERP or CNV activities, future studies that examine the malleability of these neurophysiological measures of preparation would be particularly informative.

7.3.4 Childhood predictors of future ADHD outcome

In a follow-up study of 110 participants with childhood ADHD-C diagnosis, we identified parent-rated ADHD symptoms, actigraph movement intensity, IQ and SES as significant childhood predictors of ADHD symptoms and impairment in adolescence and early adulthood. Lower SES and greater social problems in childhood also predicted a follow-up status of ADHD-persistent. None of the other cognitive measures (digit span forward (DSF), digit span backward (DSB), RTV, CE, omission errors (OE) and CI) predicted future ADHD severity or diagnosis. Co-occurring symptoms of oppositional behaviours, anxiety, social and emotional problems rated by parents were also significant predictors of future ADHD severity, but their predictive value diminished when ADHD symptoms were controlled for. Teacher ratings of childhood ADHD symptoms or co-occurring symptoms did not predict parent interview-based symptoms or diagnosis at follow up.

The lack of association between teacher ratings of childhood ADHD behaviours and interview-based parent report of ADHD symptoms and diagnosis at follow up raises the possibility that parent ratings may have more predictive power and clinical value than teacher ratings. However, as ADHD symptoms and diagnosis at follow up was based on interview-based parent report, the low correlations between teacher ratings of childhood behaviour and ADHD outcome may be a reflection of inter-rater disagreement between parent and teachers, or a result of increased in error variances from multiple informant measures. The finding that no other cognitive process except for IQ showed predictive value of future ADHD outcome is potentially consistent with the previous studies that found aetiological influences on ADHD and IQ to be separate from those on other cognitive impairments such as RTV and CE (Kuntsi et al., 2010; Wood et al., 2010a). As IQ and SES measured in childhood separately showed associations with ADHD severity at

follow up, this raises the possibility of IQ and SES as potential moderators of ADHD outcome.

7.3.5 Cognitive and neurophysiological markers of ADHD persistence and remittance

Using multiple levels of analysis in a follow-up study of 110 adolescents and young adults with childhood ADHD-CT diagnosis and 169 control participants, we examined which behavioural, cognitive and neurophysiological markers are associated with persistence or remission of ADHD symptoms and impairment. We identified three processes that underlie the developmental course of ADHD. The first process comprises preparation-vigilance-attention measures (RTV, OE, delta and theta power, CNV activity and actigraph movement measures), which are markers of remission as individuals who did not meet DSM-IV criteria for ADHD at follow up were no longer impaired on these measures. The second process involves executive control functions such as inhibition and working memory, which unlike the preparation-vigilance-attention measures did not distinguish between ADHD persisters and remitters and were not associated with ADHD symptom improvement. The effect sizes indicated that ADHD remitters were in-between ADHD persisters and controls. For IQ, a more complex developmental pattern emerged with our initial analyses showing childhood IQ to predict future ADHD outcome (chapter 5) and our subsequent analyses further showed that ADHD remitters had higher IQ at follow up than ADHD-persisters (chapter 6). Overall, our findings indicate potential moderating effects of IQ on ADHD outcome. From an intervention viewpoint, our findings highlight in particular the malleability of the preparation-vigilance-attention processes, which are potential candidates for the development of non-pharmacological interventions involving cognitive training and neurofeedback.

7.4 WIDER IMPLICATIONS FOR ADHD

7.4.1 Separation of cognitive impairment factors in ADHD

The familial separation of executive control (e.g. response inhibition and working memory) and proposed bottom-up processes of arousal regulation (e.g. RTV/intra-individual variability) has previously been demonstrated in two independent studies of ADHD and control sibling pairs (Frazier-Wood et al., 2012; Kuntsi et al., 2010). In this thesis, we further observed this pattern of separation. First, findings from our population-based twin sample (chapter 3) revealed a genetic separation between RTV and verbal memory. Second, while RTV was significantly associated with both ADHD and RD, inhibition (CE) was uniquely related to ADHD (chapter 3). Third, RTV distinguished between ADHD persisters and remitters whereas WM and response inhibition (CE and nogo-P3) deficits were not significantly different between ADHD persisters and remitters (although none of these measures significantly differentiated between ADHD remitters and controls) (chapter 6). Consistent with this separation, correlation analyses also indicated significant association with dimensional measures of ADHD symptoms and impairment at follow up for RTV, but not for inhibition and working memory (chapter 6).

The separation of cognitive processes underlying ADHD lends support for the theoretical models of ADHD that emphasise the inter-independence between two sets of processes: top-down cortical control processes and proposed bottom-up arousal regulatory functions (Halperin & Schulz, 2006; Halperin et al., 2008). The neurobiological substrates underlying these processes and their connections require future investigation using neuroimaging techniques, but emerging evidence from fMRI studies in ADHD also indicates possible separation between the frontal-parietal network that underpins executive processes, the default mode network and the ventral and dorsal attentional networks (Castellanos & Proal, 2012; Cortese et al., 2012).

Longitudinal structural MRI studies indicate that prefrontally-mediated brain structures continue to develop throughout adolescence and early adulthood (Shaw et al., 2006); and recent longitudinal ERP studies in ADHD also provided evidence for developmental lag for inhibitory (nogo-P3) but not for attentional (cue-P3) processes (Doehnert et al., 2010). As such, the lack of ADHD-persistent vs remittent group differences in nogo-P3, CE and DSB observed in our study could potentially be due to the age of follow up in our sample, which was relatively young (age between 12 to 26 years). It remains possible that the ADHD remitters would continue to show developmental improvement in executive functions into their late twenties. Future follow-up studies of these young adults into later adulthood would be important to clarify this possibility.

7.4.2 The role of IQ in ADHD

Throughout this thesis, we have demonstrated the role of IQ in the developmental course and outcome of ADHD. Aetiological findings from this thesis and previous twin and family studies have suggested that the co-occurrence between ADHD and low IQ is due to aetiological influences that are largely independent of those shared with other cognitive impairments, including reading, RTV, response inhibition and sustained attention. The aetiological separation between IQ and other specific cognitive processes in relation to ADHD is also consistent with our observation that IQ plays a distinctive role in the course and outcome of ADHD. IQ not only predicts outcome, but also distinguishes between those who show developmental improvement and those who continue to exhibit ADHD-related symptoms and impairment at follow up. While some cognitive functions are also associated with the developmental improvement of ADHD severity, these processes in childhood did not have significant predictive value for ADHD outcome.

Overall, although the aetiological and developmental pathways underlying cognitive impairments and general cognitive deficits (IQ) in relation to ADHD are partially separate, in this thesis we demonstrated the key role of IQ in the developmental course and outcome of ADHD. As individuals with ADHD have consistently been shown to have lower average IQ scores, our findings highlight the importance of investigating its effect on the underlying processes of ADHD. The results from our follow-up study also suggest that high IQ in childhood can potentially moderate ADHD symptoms during development and result in more favourable prognosis of ADHD in the future. Although future studies and replications are needed to confirm this hypothesis, our results highlight the need for early identification of children with ADHD and concurrent low IQ. As IQ is a stable trait that is challenging to intervene, these high-risk children may benefit.

7.4.3 Malleable impairments of ADHD

In addition to demonstrating partially separable cognitive processes underlying ADHD, our findings also suggest that preparation-attention-vigilance processes may be more malleable than those of executive control functions, as the former improve concurrently with ADHD symptoms and impairment, whereas the latter processes are not associated with symptom improvement. High RTV in ADHD has been shown to normalise with stimulant medication (Rhodes et al., 2006; Scheres et al., 2003) and improves under certain task manipulations such as incentives with or without faster-event rate in both children (Andreou et al., 2007; Uebel et al., 2010) and adults with ADHD (chapter 4). Conversely, inhibition deficits in ADHD do not show such ADHD-sensitive improvement under faster event-rate and incentives (Banaschewski et al., 2012; Kuntsi et al., 2009; Uebel et al., 2010), and findings on the effect of stimulant medication on inhibition deficits in ADHD have been less consistent.

On a neurophysiological level, the introduction of reward and faster event rate normalised the attenuated ‘unadjusted’ early-P3 amplitudes (without prestimulus ERP subtraction) in ADHD (chapter 4); and EEG/ERP measures of early-P3 amplitudes, theta and delta activity also demonstrated malleability as these measures either differentiated between ADHD persisters and remitters or improved concurrently with ADHD symptoms, or both (chapter 6). To the contrary, WM and inhibition processes did not distinguish between ADHD persisters and remitters and were not associated with ADHD symptom improvement (chapter 6). Taken together, our findings indicate that compared to executive control processes, measures of proposed bottom-up arousal regulation and attention are more malleable and show stronger associations with ADHD outcome.

7.4.5 Socio-economic background as a risk/protective factor for ADHD outcome

The effect of environmental adversity on structural and functional brain development in the critical early years has been well documented in brain imaging studies (Tomalski & Johnson, 2010). In particular, SES in childhood has been associated with atypical cognitive and neural functioning in adulthood, such as reduced prefrontal brain activity during executive control of attention (Kishiyama, Boyce, Jimenez, Perry, & Knight, 2009) and increased theta activity during rest (D'Angiulli, Herdman, Stapells, & Hertzman, 2008). However, the extent to which these findings are attributable to low IQ of ADHD probands or their parents were not investigated in these studies. Although we did not specifically examine the effect of SES in childhood on later cognitive and brain functions in this thesis, we showed that SES in childhood predicted future ADHD severity and diagnosis, even beyond effects shared with IQ. It is possible that individuals with ADHD who grow up in enriched environment have better access to treatment and resources that help them cope with their ADHD symptoms. Moreover, SES reflects not only the environment but is a familial factor that is closely linked to other inherited

characteristics such as parental psychopathology, maternal care-giving behaviour, and the availability of environmental stimulation (Pinquart & Sorensen, 2000). The potential moderating effects of SES on future ADHD symptoms, as suggested in our study (chapter 5), should be investigated in future studies with rigorous study designs using large longitudinal follow-up samples.

7.4.6 Categorical vs dimensional approach to ADHD

Overall, our data provide support for the use of dimensional approach to study ADHD symptoms. Using a clinical sample of ADHD probands, where ADHD was defined based on diagnostic status (chapter 2), we replicated the findings from a general population sample of twins that defined ADHD as a continuous measure of symptoms (Paloyelis et al., 2010). In chapters 5 and 6, we examined ADHD as both a categorical diagnosis and as a continuous measure of symptoms and impairment, and both approaches yielded similar results.

The issue of defining ADHD outcome based on categorical diagnosis or dimensional measure of ADHD symptoms and impairment is complex. Although our findings using both approaches were largely consistent (chapters 5 and 6), a few discrepancies were observed. For example, childhood IQ scores were associated with ADHD severity at follow up, but did not differentiate between ADHD remitters and persisters (chapter 5). This inconsistency could be a reflection of the small sample size in the ADHD-remittent group (n=23), which was due to a high rate persistence observed in our follow-up sample. Similarly, adjusted early-P3 amplitude measured at follow up did not distinguish between ADHD remitters and persisters (chapter 6), but a closer inspection using the dimensional approach revealed that this measure is uniquely associated with ADHD symptoms and not with impairment. This finding also highlights the advantages of

examining ADHD symptoms and impairment separately using the dimensional approach. Taken together, the discrepancies in findings observed between the two approaches highlight the problems of arbitrary cut-offs using categorical approach, and the value in examining both categorical and dimensional approaches in order to obtain a more complete picture.

7.4.7 Definition of ADHD persistence

The rate of persistence in our follow-up sample was high (79%), and of the 23 individuals who no longer met DSM-IV criteria for ADHD at follow up, only nine participants showed full remission of symptoms. The high persistence rate in this sample could reflect the severity of ADHD in this group, as all participants with ADHD had combined-type diagnosis in childhood. ADHD diagnosis at follow-up assessment in our study was made based on parent report during interviews. Previous studies have found substantially lower persistence rates using self-report, compared to parent report (Faraone et al., 2006a); but it is unclear whether the higher persistence rate obtained from parent report could partly reflect an over-reporting of symptoms. The low heritability estimates of self-report ADHD symptoms in adolescents reported in previous studies also raise concerns about the reliability of using participant self report in this age group (Martin et al., 2002; Merwood et al., 2013). These classification issues require further investigations in future studies, and more emphasis should be placed on incorporating objective measures of ADHD symptoms. In our follow-up studies (chapters 4, 5 and 6), we used structured clinical interviews based on parent-report in order to be consistent with the measure obtained at the initial assessment in childhood. We also used actigraph measures as a potential objective measure of ADHD symptoms and considered ADHD symptoms using both dimensional and categorical approaches when possible.

7.4.8 Prestimulus baseline subtraction

Although a conventional ERP approach is to routinely remove prestimulus ERP activity as one of the standard ERP pre-processing steps, there is also evidence to suggest that this approach can distort post-stimulus topographies (Brandeis and Lehmann et al., 1986; Lehmann et al., 1987; Koenig et al., 2009). Thus, it is argued that ERP components with baseline correction reflect the absolute *change* in neural activity elicited by the stimulus – assuming that there is no systematic neural activity during the prestimulus interval - whereas ERP measures without baseline correction are thought to reflect the absolute state of neural activity measured at a given time (Brandeis et al., 1986). Previous ERP studies using the CPT-OX have consistently obtained interpretable topographic components (e.g. CNV and cue and nogo-P3) without baseline correction (McLoughlin et al., 2011; 2012; Doehnert et al., 2011; 2012; Albercht et al., 2013); therefore, to be consistent with this approach, we interpreted the ERP components without correcting for prestimulus baseline activity in this task (chapter 6). However, as the Fast Task has not previously been used in EEG studies, and the topographies of the ERP components have not been well established, we analysed our EEG data both without and with baseline correction to empirically test the effect of prestimulus baseline activity on post-stimulus ERPs. Our findings on the Fast Task emphasise the usefulness of both approaches in obtaining a complete picture of the results for a novel ERP task, in which two experimental conditions elicited different prestimulus activity – which is key to understanding subsequent neurophysiological and cognitive processing.

7.5 STRENGTHS AND LIMITATIONS

7.5.1 Sample sizes

One of the main strengths of this thesis is the sample size of the studies, which were large in comparison to other comparable published studies. In particular, the follow-up study

in chapter 6 is one of the largest cognitive and EEG follow-up studies of ADHD to date, which consisted of a total of 404 participants (although data from the unaffected siblings of ADHD probands (n=125) were not presented in this thesis). The sample size for the ADHD-remittent group in this study was small (n=23), however, reflecting the high persistence rate of our sample. The general population sample of twins used in chapter 3 included 644 twin pairs and 24 singletons (n = 1312 children). Despite the sample providing ample power for most of the analyses presented in this thesis, the sample size was still insufficient for distinguishing between additive (A) and dominant (D) genetic influences and therefore broad-sense heritability was modelled.

One of the main difficulties with integrating neurocognitive and genetic study designs is the difference in sample size needed for each research discipline. Genetic studies require sample size of hundreds and thousands for sufficient power to estimate genetic influences, whereas the cost and time taken to collect and analyse neurocognitive data limit the number of participants included in these studies. Some attempts to address this issue have been made by stratifying individuals by genotypes and selecting those with extreme genetic characteristics for neurocognitive measures. Collaboration between multiple sites across countries is also another possible solution, however it is crucial to have strict monitoring of the consistency in measures and procedures used across research sites.

7.5.2 Definition of ADHD

Another strength of this thesis is the comprehensive consideration of different definitions of ADHD using both dimensional and categorical approaches, aggregating multiple informant measures and incorporating objective measures of ADHD symptoms (chapters 5 and 6).

7.5.3 Age range

The age range of the general population sample of twins (chapter 3) was restricted to middle childhood (between 7 and 10 years old); therefore it is unclear whether results from this study can be generalised to those later in development. On the contrary, the age range of our follow-up study (chapters 5 and 6) of the clinical sample was wide, spanning over 14 years, which could result in heterogeneity in behavioural, cognitive and neurophysiological profiles. However, our findings indicate similar behavioural and cognitive characteristics among those with persistent ADHD – from childhood to adolescence and early adulthood. The high rates of persistence in this follow-up sample may also be a reflection of the age of our follow-up sample, which is relatively young, emphasising the need for future follow up studies of this sample into later adulthood.

7.5.4 Measurement and multiple testing issues

The integration of measurements across different domains and combining rating scales with objective measures are strengths of this thesis. In chapter 2, we included both subjective (parent ratings) and objective measures of reading ability (TOWRE); and in chapters 5 and 6, actigraph measures of activity level were used as an objective measure of overactivity in ADHD, which revealed similar patterns as those indicated by parent rated symptoms, both demonstrated strong predictive value for ADHD outcome and distinguished between ADHD persisters and remitters.

While a multi-disciplinary approach enables a more thorough investigation of a range of processes underlying ADHD, the diversity of measures also introduces potential challenges relating to multiple testing. In the follow-up study, it would not have been appropriate to correct for multiple testing using the standard procedures, such as Bonferroni correction or false-discovery rate, as these statistical methods assume

independence in hypothesis tests (Leek & Storey, 2008). Since the variables included in our studies were highly dependent (e.g. between EEG and ERP measures), it would have been inappropriate to ignore the dependence among hypothesis tests, as this would increase the chances of introducing type-two errors. For these reasons, we placed emphasis on interpreting the effect sizes as well as the significance levels. However, due to the exploratory nature of these analyses, future replication of the findings will be crucial.

In chapter 6, we also took a more hypothesis-driven approach and selected only the variables that have previously demonstrated sensitivity to ADHD, in order to reduce the number of hypotheses tested. As such, one of the limitations of our study is that we exclusively examined EEG frequency bands measures from the frontal location. It therefore remains unclear whether our findings can be generalised to other brain areas. We chose to only include frontal EEG measures for several reasons: 1) EEG power measured from all regions were highly correlated ($p=0.80$); 2) we aimed primarily to identify markers of ADHD persistence and remittance rather than examining the spatial and functional differences of these measures; 3) previous studies have consistently indicated that frontal EEG abnormalities show the strongest associations with ADHD (Snyder & Hall, 2006). For ERP measures, our findings were limited to amplitude measures, as we did not test group differences on peak latencies. We chose to examine exclusively amplitude measures for two reasons: 1) there is stronger and more consistent evidence for ADHD and control differences for amplitude measures (Johnstone, Barry, & Clarke, 2013); 2) as we used an area under the curve measure for P3 amplitudes in the Fast Task (chapter 4), latency measures could not be examined. As we have established which EEG and ERP measures are the most informative for understanding the processes of ADHD persistence and remittance, future studies can

further examine the temporal and spatial properties of these markers in relation the course and outcome of ADHD.

7.5.5 Effects of medication

All participants in cognitive and EEG studies (chapters 4, 5 and 6) were instructed to abstain from any stimulant or non-stimulant ADHD medication 48 hours before testing; therefore our findings cannot be attributed to any short-term medication effects. However, as it was not possible to control for any potential more long-term medication effects, we cannot determine whether our findings are attributable to individual differences in long-term medication.

7.6 FUTURE DIRECTIONS

7.6.1 Replication

Besides chapter 2, which is a replication and an extension of a previous study, the findings from the remaining studies were novel and require future replications in independent samples before any firm conclusions can be drawn. Chapter 4 is the first ERP study on the Fast Task; therefore it is especially important to replicate the findings from this study in another sample. Our findings on cognitive and EEG markers of ADHD persistence and remittance are also novel; and future replications with older adults and a larger ADHD-remittent sample are essential for confirming these findings.

7.6.2 Examining other definitions of ADHD

In chapters 4, 5 and 6, we defined ADHD based strictly on the DSM-IV criteria reported by parents. Future studies should investigate further the reliability and value of different informant reports (e.g. participant self-report vs parent report), as well as consider the contribution of objective measures such as actigraph measures of activity level, and

replicate these findings using a more revised classification system of ADHD (DSM-V). Longitudinal studies using multiple-level of measurements would also be useful to investigate which informant measures of ADHD are the most reliable for this age group.

7.6.3 Developmental course and outcome of cognitive impairment

Although childhood measures of cognitive processes were used in this thesis only to determine their predictive value on ADHD outcome (chapter 5), we plan to use data from both time points (childhood and adolescence/early adulthood) using cross-lagged analyses to further examine the direction of causality of these processes.

7.6.4 Very-low frequency oscillations and ADHD

There is increasing evidence from neuroimaging studies to suggest that ADHD is characterised by a dysfunctional default mode network (DMN) (Castellanos & Proal, 2012), which reflects deficits in cognitive resource allocation (Rosler, Heil, & Roder, 1997) and modulation of gross cortical excitability (Vanhatalo et al., 2004). Very low-frequency (VLF; < 0.05 Hz) fluctuations measured using EEG have been hypothesised to be associated with the brain's DMN and reflecting arousal levels. Reduced power in the EEG low frequency range (0.06-0.2Hz) during rest was associated with higher inattentive symptom in adults with ADHD (Helps, James, Debener, Karl, & Sonuga-Barke, 2008), and reduced VLF attenuation from rest to task condition in ADHD have been associated with higher number of errors and increased RTV (Helps et al., 2010). We plan to extend our findings on the neurophysiological basis of increased RTV and its improvement using the Fast Task (chapter 4) by including more specific and objective measures of arousal, such as VLF and skin conductance measures.

7.6.5 Familial model fitting analyses

Another future direction for analyses on the follow-up data is to use structural equation modelling to investigate whether RTV and OE mediate ADHD outcome, and examine the continuity of the aetiological influences underlying the two familial cognitive impairment factors identified during initial assessments (Kuntsi et al., 2010). We also plan to examine the familial factor structure underlying the neurophysiological processes measured at follow up. We predict that similar to the patterns observed for cognitive processes during childhood assessments, the aetiological influences on ADHD and response inhibition (nogo-P3) will separate from those on neurophysiological processes of preparation (CNV) and attention (parietal or cue-P3).

7.7 OVERALL CONCLUSION

In this thesis, we used a multi-disciplinary approach to study the aetiological influences underlying ADHD and reading difficulties, the developmental course and outcomes of behavioural and cognitive impairments in ADHD. We also identified cognitive and neurophysiological processes underlying ADHD persistence and remittance. Using data from a general population sample of twins and a clinical sample of ADHD and control sibling-pairs, we examined the aetiological, cognitive and neurophysiological processes underlying ADHD using both categorical and dimensional definitions of ADHD. The findings and implications discussed in this thesis testify the value of combining multiple levels of analyses from genetic influences, brain, cognition and behaviour to gain a more thorough understanding of ADHD.

Our findings indicate that reaction time variability (RTV), in particular, show promise as a candidate intermediate phenotype that i) captures some shared genetic influences underlying inattention symptoms and reading difficulties; ii) show malleability under

task conditions with incentives and fast event rate in both childhood and adulthood; iii) distinguishes between ADHD persisters and remitters and is associated with ADHD symptom improvement; and iv) potentially mediates ADHD outcome and is a candidate target for future development of non-pharmacological interventions. Future work should further clarify the neurobiological and neurophysiological basis of RTV in the context of cognitive training and neurofeedback treatment programmes.

The temporal precision of EEG allowed for a novel investigation of the temporal sequence of neuronal processes underlying increased and improved RTV in ADHD. We showed that the neurophysiological marker of attentional alerting underlies increased RTV and its improvement in ADHD; and improves concurrently with ADHD symptom improvement. Although previous longitudinal findings on CNV suggest that abnormalities in neural preparation in ADHD are developmentally stable deficits, findings from our follow-up study suggest that CNV from the CPT-OX represents one of the markers of ADHD remission. The extent to which neurophysiological preparation is a malleable process that is a potential target for treatment warrants further investigation.

Another prominent and consistent finding from this thesis is the separation between executive control functions (e.g. response inhibition and working memory) and measures of attention fluctuation, preparation and vigilance. This pattern was consistently observed on multiple-level of analyses from genetic studies to cognitive and neurophysiological measures. Future studies that integrate brain-imaging techniques with cognitive-EEG measures will be particularly useful in clarifying the developmental patterns and trajectories of these separable processes in relation to the course and outcome of ADHD.

References

- Ahmadlou, M., Adeli, H., & Adeli, A. (2012). Graph theoretical analysis of organization of functional brain networks in ADHD. *Clin EEG Neurosci*, *43*(1), 5-13.
- Albrecht, B., Brandeis, D., Uebel, H., Heinrich, H., Heise, A., Hasselhorn, M., et al. (2010). Action monitoring in children with or without a family history of ADHD--effects of gender on an endophenotype parameter. *Neuropsychologia*, *48*(4), 1171-1177.
- Albrecht, B., Brandeis, D., Uebel, H., Valko, L., Heinrich, H., Drechsler, R., et al. (2012). Familiality of neural preparation and response control in childhood attention deficit-hyperactivity disorder. *Psychol Med*, 1-15.
- American Psychiatric Association. (1968). *Diagnostic and Statistical Manual of Mental Disorders, 2nd Edition (DSM-II)*. Washington.
- American Psychiatric Association. (1980). *Diagnostic and Statistical Manual of Mental Disorders, 3rd Edition (DSM-III)*. Washington.
- American Psychiatric Association. (1994). *Diagnostic and Statistical Manual of Mental Disorders, Forth Edition (DSM-IV)*. Washington.
- American Psychiatric Association. (2000). *Diagnostic and Statistical Manual of Mental Disorders, Forth Edition, Text Revision (DSM-IV-TR)*. Washington.
- American Psychiatric Association. (2013). *Diagnostic and Statistical Manual of Mental Disorders, Fifth Edition (DSM-V)*. Washington.
- Amiri, S., Fakhari, A., Maheri, M., & Mohammadpoor Asl, A. (2010). Attention deficit/hyperactivity disorder in primary school children of Tabriz, North-West Iran. *Paediatr Perinat Epidemiol*, *24*(6), 597-601.
- Andreou, P., Neale, B. M., Chen, W., Christiansen, H., Gabriels, I., Heise, A., et al. (2007). Reaction time performance in ADHD: improvement under fast-incentive condition and familial effects. *Psychol Med*, *37*(12), 1703-1715.
- Arns, M., de Ridder, S., Strehl, U., Breteler, M., & Coenen, A. (2009). Efficacy of neurofeedback treatment in ADHD: the effects on inattention, impulsivity and hyperactivity: a meta-analysis. *Clin EEG Neurosci*, *40*(3), 180-189.
- Asherson, P. (2005). Clinical assessment and treatment of attention deficit hyperactivity disorder in adults. *Expert Rev Neurother*, *5*(4), 525-539.
- Astrom, R., DeFries, J. C., Pennington, B., Wadsworth, S. J., & Willcutt, E. (2009). Etiology of covariation between a parent-report screening measure and reading performance. *Behaviour Genetics*, *39*(6), 634.
- August, G., & Garfinkel, B. (1990). Comorbidity of ADHD and reading disability among clinic referred children. *Journal of Abnormality Child Psychology*, *18*, 29-45.

- Banaschewski, T., Brandeis, D., Heinrich, H., Albrecht, B., Brunner, E., & Rothenberger, A. (2003). Association of ADHD and conduct disorder--brain electrical evidence for the existence of a distinct subtype. *J Child Psychol Psychiatry, 44*(3), 356-376.
- Banaschewski, T., Brandeis, D., Heinrich, H., Albrecht, B., Brunner, E., & Rothenberger, A. (2004). Questioning inhibitory control as the specific deficit of ADHD--evidence from brain electrical activity. *J Neural Transm, 111*(7), 841-864.
- Banaschewski, T., Hollis, C., Oosterlaan, J., Roeyers, H., Rubia, K., Willcutt, E. G., et al. (2005). Towards an understanding of unique and shared pathways in the psychopathophysiology of ADHD. *Dev Sci, 8*(2), 132-140.
- Banaschewski, T., Jennen-Steinmetz, C., Brandeis, D., Buitelaar, J. K., Kuntsi, J., Poustka, L., et al. (2012). Neuropsychological correlates of emotional lability in children with ADHD. *J Child Psychol Psychiatry, 53*(11), 1139-1148.
- Banaschewski, T., Poustka, L., & Holtmann, M. (2011). [Autism and ADHD across the life span. Differential diagnoses or comorbidity?]. *Nervenarzt, 82*(5), 573-580.
- Barkley, R., & Murphy, K. (2006a). *Attention Deficit Hyperactivity Disorder: A Clinical Workbook (3rd Edition)*. New York: Guildford Press.
- Barkley, R. A. (1997). Behavioral inhibition, sustained attention, and executive functions: constructing a unifying theory of ADHD. *Psychol Bull, 121*(1), 65-94.
- Barkley, R. A. (1998). *Attention-Deficit/Hyperactivity Disorder: A Handbook of Diagnosis and Treatment. 2nd ed.* New York, NY: Guilford Press.
- Barkley, R. A., Fischer, M., Edelbrock, C. S., & Smallish, L. (1990). The adolescent outcome of hyperactive children diagnosed by research criteria: I. An 8-year prospective follow-up study. *J Am Acad Child Adolesc Psychiatry, 29*(4), 546-557.
- Barkley, R. A., Fischer, M., Smallish, L., & Fletcher, K. (2002). The persistence of attention-deficit/hyperactivity disorder into young adulthood as a function of reporting source and definition of disorder. *J Abnorm Psychol, 111*(2), 279-289.
- Barkley, R. A., Grodzinsky, G., & DuPaul, G. J. (1992). Frontal lobe functions in attention deficit disorder with and without hyperactivity: a review and research report. *J Abnorm Child Psychol, 20*(2), 163-188.
- Barkley, R. A., & Murphy, K. (2006b). *Attention Deficit Hyperactivity Disorder: A Clinical Workbook (3rd ed.)*. New York: Guildford Press.
- Barkley, R. A., & Murphy, K. (2006c). *Attention Deficit Hyperactivity Disorder: A Clinical Workbook (3rd Edition)*. New York: Guildford Press.

- Barry, R. J., Clarke, A. R., & Johnstone, S. J. (2003a). A review of electrophysiology in attention-deficit/hyperactivity disorder: I. Qualitative and quantitative electroencephalography. *Clin Neurophysiol*, *114*(2), 171-183.
- Barry, R. J., Clarke, A. R., Johnstone, S. J., Brown, C. R., Bruggemann, J. M., & van Rijbroek, I. (2009a). Caffeine effects on resting-state arousal in children. *Int J Psychophysiol*, *73*(3), 355-361.
- Barry, R. J., Clarke, A. R., Johnstone, S. J., McCarthy, R., & Selikowitz, M. (2009b). Electroencephalogram theta/beta ratio and arousal in attention-deficit/hyperactivity disorder: evidence of independent processes. *Biol Psychiatry*, *66*(4), 398-401.
- Barry, R. J., Clarke, A. R., McCarthy, R., Selikowitz, M., Rushby, J. A., & Ploskova, E. (2004). EEG differences in children as a function of resting-state arousal level. *Clin Neurophysiol*, *115*(2), 402-408.
- Barry, R. J., Johnstone, S. J., & Clarke, A. R. (2003b). A review of electrophysiology in attention-deficit/hyperactivity disorder: II. Event-related potentials. *Clin Neurophysiol*, *114*(2), 184-198.
- Bedard, A. C., Trampush, J. W., Newcorn, J. H., & Halperin, J. M. (2010). Perceptual and motor inhibition in adolescents/young adults with childhood-diagnosed ADHD. *Neuropsychology*, *24*(4), 424-434.
- Berkson, J. (1946). Limitations of the application of fourfold table analysis hospital data. *Biometrics Bull*(2), 47-53.
- Berlin, L., Bohlin, G., & Rydell, A. M. (2003). Relations between inhibition, executive functioning, and ADHD symptoms: a longitudinal study from age 5 to 8(1/2) years. *Child Neuropsychol*, *9*(4), 255-266.
- Berwid, O. G., Curko Kera, E. A., Marks, D. J., Santra, A., Bender, H. A., & Halperin, J. M. (2005). Sustained attention and response inhibition in young children at risk for Attention Deficit/Hyperactivity Disorder. *J Child Psychol Psychiatry*, *46*(11), 1219-1229.
- Bidwell, L. C., Willcutt, E. G., Defries, J. C., & Pennington, B. F. (2007). Testing for neuropsychological endophenotypes in siblings discordant for attention-deficit/hyperactivity disorder. *Biol Psychiatry*, *62*(9), 991-998.
- Biederman, J. (2005). Attention-deficit/hyperactivity disorder: a selective overview. *Biol Psychiatry*, *57*(11), 1215-1220.

- Biederman, J., Faraone, S., Milberger, S., Curtis, S., Chen, L., Marrs, A., et al. (1996). Predictors of persistence and remission of ADHD into adolescence: results from a four-year prospective follow-up study. *J Am Acad Child Adolesc Psychiatry, 35*(3), 343-351.
- Biederman, J., Faraone, S. V., Milberger, S., & Doyle, A. (1993). Diagnoses of attention-deficit hyperactivity disorder from parent reports predict diagnoses based on teacher reports. *J Am Acad Child Adolesc Psychiatry, 32*(2), 315-317.
- Biederman, J., Faraone, S. V., Spencer, T., Wilens, T., Mick, E., & Lapey, K. A. (1994). Gender differences in a sample of adults with attention deficit hyperactivity disorder. *Psychiatry Res, 53*(1), 13-29.
- Biederman, J., Faraone, S. V., Taylor, A., Sienna, M., Williamson, S., & Fine, C. (1998). Diagnostic continuity between child and adolescent ADHD: findings from a longitudinal clinical sample. *J Am Acad Child Adolesc Psychiatry, 37*(3), 305-313.
- Biederman, J., Mick, E., & Faraone, S. V. (2000). Age-dependent decline of symptoms of attention deficit hyperactivity disorder: impact of remission definition and symptom type. *Am J Psychiatry, 157*(5), 816-818.
- Biederman, J., Newcorn, J., & Sprich, S. (1991). Comorbidity of attention deficit hyperactivity disorder with conduct, depressive, anxiety, and other disorders. *Am J Psychiatry, 148*(5), 564-577.
- Biederman, J., Petty, C. R., Ball, S. W., Fried, R., Doyle, A. E., Cohen, D., et al. (2009). Are cognitive deficits in attention deficit/hyperactivity disorder related to the course of the disorder? A prospective controlled follow-up study of grown up boys with persistent and remitting course. *Psychiatry Res, 170*(2-3), 177-182.
- Biederman, J., Petty, C. R., Clarke, A., Lomedico, A., & Faraone, S. V. (2011). Predictors of persistent ADHD: an 11-year follow-up study. *J Psychiatr Res, 45*(2), 150-155.
- Biederman, J., Petty, C. R., Evans, M., Small, J., & Faraone, S. V. (2010). How persistent is ADHD? A controlled 10-year follow-up study of boys with ADHD. *Psychiatry Res, 177*(3), 299-304.
- Biederman, J., Petty, C. R., Fried, R., Doyle, A. E., Spencer, T., Seidman, L. J., et al. (2007). Stability of executive function deficits into young adult years: a prospective longitudinal follow-up study of grown up males with ADHD. *Acta Psychiatr Scand, 116*(2), 129-136.
- Boomsma, D. I., Saviouk, V., Hottenga, J. J., Distel, M. A., de Moor, M. H., Vink, J. M., et al. (2010). Genetic epidemiology of attention deficit hyperactivity disorder (ADHD index) in adults. *PLoS One, 5*(5), e10621.

- Borger, N., & van der Meere, J. (2000). Motor control and state regulation in children with ADHD: a cardiac response study. *Biol Psychol*, *51*(2-3), 247-267.
- Brandeis, D., & Lehmann, D. (1986). Event-related potentials of the brain and cognitive processes: approaches and applications. *Neuropsychologia*, *24*(1), 151-168.
- Brassett-Harknett, A., & Butler, N. (2007). Attention-deficit/hyperactivity disorder: an overview of the etiology and a review of the literature relating to the correlates and lifecourse outcomes for men and women. *Clin Psychol Rev*, *27*(2), 188-210.
- Bresnahan, S. M., Anderson, J. W., & Barry, R. J. (1999). Age-related changes in quantitative EEG in attention-deficit/hyperactivity disorder. *Biol Psychiatry*, *46*(12), 1690-1697.
- Bresnahan, S. M., & Barry, R. J. (2002). Specificity of quantitative EEG analysis in adults with attention deficit hyperactivity disorder. *Psychiatry Res*, *112*(2), 133-144.
- Brocki, K. C., Eninger, L., Thorell, L. B., & Bohlin, G. (2010). Interrelations between executive function and symptoms of hyperactivity/impulsivity and inattention in preschoolers: a two year longitudinal study. *J Abnorm Child Psychol*, *38*(2), 163-171.
- Brocki, K. C., Nyberg, L., Thorell, L. B., & Bohlin, G. (2007). Early concurrent and longitudinal symptoms of ADHD and ODD: relations to different types of inhibitory control and working memory. *J Child Psychol Psychiatry*, *48*(10), 1033-1041.
- Burt, S. A. (2009). Rethinking environmental contributions to child and adolescent psychopathology: a meta-analysis of shared environmental influences. *Psychol Bull*, *135*(4), 608-637.
- Campbell, S. B., & von Stauffenberg, C. (2009). Delay and inhibition as early predictors of ADHD symptoms in third grade. *J Abnorm Child Psychol*, *37*(1), 1-15.
- Canino, G., Shrout, P. E., Rubio-Stipec, M., Bird, H. R., Bravo, M., Ramirez, R., et al. (2004). The DSM-IV rates of child and adolescent disorders in Puerto Rico: prevalence, correlates, service use, and the effects of impairment. *Arch Gen Psychiatry*, *61*(1), 85-93.
- Cardon, L. R., Dially, L. F., Plomin, R., DeFries, J. C., & Fulker, D. W. (1990). Genetic correlations between reading performance and IQ in the Colorado Adoption Project. *Intelligence*, *14*, 245-257.
- Carroll, J. M., Maughan, B., Goodman, R., & Meltzer, H. (2005). Literacy difficulties and psychiatric disorders: evidence for comorbidity. *J Child Psychol Psychiatry*, *46*(5), 524-532.

- Castellanos, F. X., & Proal, E. (2012). Large-scale brain systems in ADHD: beyond the prefrontal-striatal model. *Trends Cogn Sci*, *16*(1), 17-26.
- Castellanos, F. X., Sonuga-Barke, E. J., Milham, M. P., & Tannock, R. (2006). Characterizing cognition in ADHD: beyond executive dysfunction. *Trends Cogn Sci*, *10*(3), 117-123.
- Castellanos, F. X., Sonuga-Barke, E. J., Scheres, A., Di Martino, A., Hyde, C., & Walters, J. R. (2005). Varieties of attention-deficit/hyperactivity disorder-related intra-individual variability. *Biol Psychiatry*, *57*(11), 1416-1423.
- Chabot, R. J., & Serfontein, G. (1996). Quantitative electroencephalographic profiles of children with attention deficit disorder. *Biol Psychiatry*, *40*(10), 951-963.
- Chen, W., & Taylor, E. (2005). Resilience, hyperactivity and impaired self-control. In S. Goldstein & R. Brooks (Eds.). *Handbook of Resilience in Children* (pp. 257-278). New York: Kluwer.
- Chen, W., Zhou, K., Sham, P., Franke, B., Kuntsi, J., Campbell, D., et al. (2008). DSM-IV combined type ADHD shows familial association with sibling trait scores: a sampling strategy for QTL linkage. *Am J Med Genet B Neuropsychiatr Genet*, *147B*(8), 1450-1460.
- Cheung, C. H., Wood, A. C., Paloyelis, Y., Arias-Vasquez, A., Buitelaar, J. K., Franke, B., et al. (2012). Aetiology for the covariation between combined type ADHD and reading difficulties in a family study: the role of IQ. *J Child Psychol Psychiatry*, *53*(8), 864-873.
- Clarke, A. R., Barry, R. J., Dupuy, F. E., McCarthy, R., Selikowitz, M., & Johnstone, S. J. (2013). Excess beta activity in the EEG of children with attention-deficit/hyperactivity disorder: A disorder of arousal? *Int J Psychophysiol*.
- Clarke, A. R., Barry, R. J., McCarthy, R., & Selikowitz, M. (1998). EEG analysis in Attention-Deficit/Hyperactivity Disorder: a comparative study of two subtypes. *Psychiatry Res*, *81*(1), 19-29.
- Clarke, A. R., Barry, R. J., McCarthy, R., & Selikowitz, M. (2001a). Age and sex effects in the EEG: differences in two subtypes of attention-deficit/hyperactivity disorder. *Clin Neurophysiol*, *112*(5), 815-826.
- Clarke, A. R., Barry, R. J., McCarthy, R., & Selikowitz, M. (2001b). Excess beta activity in children with attention-deficit/hyperactivity disorder: an atypical electrophysiological group. *Psychiatry Res*, *103*(2-3), 205-218.

- Clarke, A. R., Barry, R. J., McCarthy, R., Selikowitz, M., Brown, C. R., & Croft, R. J. (2003). Effects of stimulant medications on the EEG of children with Attention-Deficit/Hyperactivity Disorder Predominantly Inattentive type. *Int J Psychophysiol*, *47*(2), 129-137.
- Clarke, A. R., Barry, R. J., McCarthy, R., Selikowitz, M., & Croft, R. J. (2002). EEG differences between good and poor responders to methylphenidate in boys with the inattentive type of attention-deficit/hyperactivity disorder. *Clin Neurophysiol*, *113*(8), 1191-1198.
- Coghill, D. R., Rhodes, S. M., & Matthews, K. (2007). The neuropsychological effects of chronic methylphenidate on drug-naive boys with attention-deficit/hyperactivity disorder. *Biol Psychiatry*, *62*(9), 954-962.
- Cohen, J. (1988). *Statistical Power Analysis for the Behavioural Sciences (second ed.)*. Lawrence Erlbaum Associates.
- Cohen, J. (1992). A power primer. *Psychol Bull*, *112*(1), 155-159.
- Conners, C. K., Sitarenios, G., Parker, J. D., & Epstein, J. N. (1998a). The revised Conners' Parent Rating Scale (CPRS-R): factor structure, reliability, and criterion validity. *J Abnorm Child Psychol*, *26*(4), 257-268.
- Conners, C. K., Sitarenios, G., Parker, J. D., & Epstein, J. N. (1998b). Revision and restandardization of the Conners Teacher Rating Scale (CTRS-R): factor structure, reliability, and criterion validity. *J Abnorm Child Psychol*, *26*(4), 279-291.
- Cornelius, M. D., & Day, N. L. (2009). Developmental consequences of prenatal tobacco exposure. *Curr Opin Neurol*, *22*(2), 121-125.
- Cortese, S., Kelly, C., Chabernaud, C., Proal, E., Di Martino, A., Milham, M. P., et al. (2012). Toward systems neuroscience of ADHD: a meta-analysis of 55 fMRI studies. *Am J Psychiatry*, *169*(10), 1038-1055.
- Costello, E. J., Keeler, G. P., & Angold, A. (2001). Poverty, race/ethnicity, and psychiatric disorder: a study of rural children. *Am J Public Health*, *91*(9), 1494-1498.
- Crichton, A. (1798). *An inquiry into the nature and origin of mental derangement: comprehending a concise system of the physiology and pathology of hyman mind and a history of the passion and their effects*. Cadell T Jr, Davies W. [Reprint: Crichton A (2008) *An inquiry into the nature and origin of mental derangement. On attention and its derangement. On attention and its disease*. *J Atten Disorder* *12*:200-204]. London.
- Crosbie, J., & Schachar, R. (2001a). Deficient inhibition as a marker for familial ADHD. *Am J Psychiatry*, *158*(11), 1884-1890.

- Crosbie, J., & Schachar, R. (2001b). Deficient inhibition as a marker for familial ADHD. *Am J Psychiatry, 158*, 1884-1890.
- D'Angiulli, A., Herdman, A., Stapells, D., & Hertzman, C. (2008). Children's event-related potentials of auditory selective attention vary with their socioeconomic status. *Neuropsychology, 22*(3), 293-300.
- de Jong, C. G., Van De Voorde, S., Roeyers, H., Raymaekers, R., Oosterlaan, J., & Sergeant, J. A. (2009). How distinctive are ADHD and RD? Results of a double dissociation study. *J Abnorm Child Psychol, 37*(7), 1007-1017.
- DeFries, J. C., & Fulker, D. W. (1985). Multiple regression analysis of twin data. (5), 467-473.
- Dhar, M., Been, P. H., Minderaa, R. B., & Althaus, M. (2010). Information processing differences and similarities in adults with dyslexia and adults with Attention Deficit Hyperactivity Disorder during a Continuous Performance Test: a study of cortical potentials. *Neuropsychologia, 48*(10), 3045-3056.
- Doehnert, M., Brandeis, D., Imhof, K., Drechsler, R., & Steinhausen, H. C. (2010). Mapping attention-deficit/hyperactivity disorder from childhood to adolescence--no neurophysiologic evidence for a developmental lag of attention but some for inhibition. *Biol Psychiatry, 67*(7), 608-616.
- Doehnert, M., Brandeis, D., Schneider, G., Drechsler, R., & Steinhausen, H. C. (2013). A neurophysiological marker of impaired preparation in an 11-year follow-up study of attention-deficit/hyperactivity disorder (ADHD). *J Child Psychol Psychiatry, 54*(3), 260-270.
- Doehnert, M., Brandeis, D., Straub, M., Steinhausen, H. C., & Drechsler, R. (2008). Slow cortical potential neurofeedback in attention deficit hyperactivity disorder: is there neurophysiological evidence for specific effects? *J Neural Transm, 115*(10), 1445-1456.
- Donkers, F. C., & van Boxtel, G. J. (2004). The N2 in go/no-go tasks reflects conflict monitoring not response inhibition. *Brain Cogn, 56*(2), 165-176.
- Dopfner, M., Breuer, D., Wille, N., Erhart, M., & Ravens-Sieberer, U. (2008). How often do children meet ICD-10/DSM-IV criteria of attention deficit-/hyperactivity disorder and hyperkinetic disorder? Parent-based prevalence rates in a national sample--results of the BELLA study. *Eur Child Adolesc Psychiatry, 17 Suppl 1*, 59-70.
- Douglas, V. I. (1972). Stop, look and listen: The problem of sustained attention and impulse control in hyperactive and normal children. *Canadian Journal of Behavioral Science, 4*, 259-282.

- Doyle, A. E., Faraone, S. V., Seidman, L. J., Willcutt, E. G., Nigg, J. T., Waldman, I. D., et al. (2005). Are endophenotypes based on measures of executive functions useful for molecular genetic studies of ADHD? *J Child Psychol Psychiatry*, *46*(7), 774-803.
- Dupuy, F. E., Barry, R. J., Clarke, A. R., McCarthy, R., & Selikowitz, M. (2013). Sex differences between the combined and inattentive types of attention-deficit/hyperactivity disorder: An EEG perspective. *Int J Psychophysiol*.
- Dupuy, F. E., Clarke, A. R., Barry, R. J., McCarthy, R., & Selikowitz, M. (2011). Girls with attention-deficit/hyperactivity disorder: EEG differences between DSM-IV types. *Clin EEG Neurosci*, *42*(1), 1-5.
- Dykman, R., & Ackerman, P. J. (1991). Attention deficit disorder and specific reading disability: Separate but often overlapping disorders. *Journal of Learning Disabilities*, *24*, 96-103.
- Eaton, W. O., McKeen, N. A., & Saudino, K. J. (1996). *Measuring Human Individual Differences in General motor Activity with Actometers*. In K. Ossenkopp, M. Kavaliers & P. R. Sanberg (Eds.), *measuring movement and locomotion: from invertebrates to humans*. Austin, TX.
- Eaves, L., Rutter, M., Silberg, J. L., Shillady, L., Maes, H., & Pickles, A. (2000). Genetic and environmental causes of covariation in interview assessments of disruptive behavior in child and adolescent twins. *Behav Genet*, *30*(4), 321-334.
- Ehringer, M. A., Rhee, S. H., Young, S., Corley, R., & Hewitt, J. K. (2006). Genetic and environmental contributions to common psychopathologies of childhood and adolescence: a study of twins and their siblings. *J Abnorm Child Psychol*, *34*(1), 1-17.
- Elia, J., Laracy, S., Allen, J., Nissley-Tsiopinis, J., & Borgmann-Winter, K. (2012). Epigenetics: genetics versus life experiences. *Curr Top Behav Neurosci*, *9*, 317-340.
- Epstein, J. N., Brinkman, W. B., Froehlich, T., Langberg, J. M., Narad, M. E., Antonini, T. N., et al. (2011). Effects of stimulant medication, incentives, and event rate on reaction time variability in children with ADHD. *Neuropsychopharmacology*, *36*(5), 1060-1072.
- Falkenstein, M., Hohnsbein, J., & Hoormann, J. (1995). Event-related potential correlates of errors in reaction tasks. *Electroencephalogr Clin Neurophysiol Suppl*, *44*, 287-296.

- Fallgatter, A. J., Aranda, D. R., Bartsch, A. J., & Herrmann, M. J. (2002). Long-term reliability of electrophysiologic response control parameters. *J Clin Neurophysiol*, *19*(1), 61-66.
- Fallgatter, A. J., Bartsch, A. J., Strik, W. K., Mueller, T. J., Eisenack, S. S., Neuhauser, B., et al. (2001). Test-retest reliability of electrophysiological parameters related to cognitive motor control. *Clin Neurophysiol*, *112*(1), 198-204.
- Fallgatter, A. J., Ehlis, A. C., Seifert, J., Strik, W. K., Scheuerpflug, P., Zillessen, K. E., et al. (2004). Altered response control and anterior cingulate function in attention-deficit/hyperactivity disorder boys. *Clin Neurophysiol*, *115*(4), 973-981.
- Faraone, S. V., & Biederman, J. (2005). What is the prevalence of adult ADHD? Results of a population screen of 966 adults. *J Atten Disord*, *9*(2), 384-391.
- Faraone, S. V., Biederman, J., Lehman, B. K., Keenan, K., Norman, D., Seidman, L. J., et al. (1993). Evidence for the independent familial transmission of attention deficit hyperactivity disorder and learning disabilities: results from a family genetic study. *Am J Psychiatry*, *150*(6), 891-895.
- Faraone, S. V., Biederman, J., & Mick, E. (2006a). The age-dependent decline of attention deficit hyperactivity disorder: a meta-analysis of follow-up studies. *Psychol Med*, *36*(2), 159-165.
- Faraone, S. V., Biederman, J., & Monuteaux, M. C. (2000). Attention-deficit disorder and conduct disorder in girls: evidence for a familial subtype. *Biol Psychiatry*, *48*(1), 21-29.
- Faraone, S. V., Biederman, J., Spencer, T. J., & Aleardi, M. (2006b). Comparing the efficacy of medications for ADHD using meta-analysis. *MedGenMed*, *8*(4), 4.
- Faraone, S. V., & Glatt, S. J. (2010). A comparison of the efficacy of medications for adult attention-deficit/hyperactivity disorder using meta-analysis of effect sizes. *J Clin Psychiatry*, *71*(6), 754-763.
- Faraone, S. V., Perlis, R. H., Doyle, A. E., Smoller, J. W., Goralnick, J. J., Holmgren, M. A., et al. (2005). Molecular genetics of attention-deficit/hyperactivity disorder. *Biol Psychiatry*, *57*(11), 1313-1323.
- Faraone, S. V., Sergeant, J., Gillberg, C., & Biederman, J. (2003). The worldwide prevalence of ADHD: is it an American condition? *World Psychiatry*, *2*(2), 104-113.
- Fergusson, D. M., Lynskey, M. T., & Horwood, L. J. (1993). Conduct problems and attention deficit behaviour in middle childhood and cannabis use by age 15. *Aust N Z J Psychiatry*, *27*(4), 673-682.

- Fletcher, J. M., Coulter, W. A., Reschly, D. J., & Vaughn, S. (2004). Alternative approaches to the definition and identification of learning disabilities: some questions and answers. *Ann Dyslexia*, *54*(2), 304-331.
- Fletcher, J. M., Shaywitz, S. E., & Shaywitz, B. A. (1999). Comorbidity of learning and attention disorders. Separate but equal. *Pediatr Clin North Am*, *46*(5), 885-897, vi.
- Franke, B., Neale, B. M., & Faraone, S. V. (2009). Genome-wide association studies in ADHD. *Hum Genet*, *126*(1), 13-50.
- Frazier, T. W., Demaree, H. A., & Youngstrom, E. A. (2004). Meta-analysis of intellectual and neuropsychological test performance in attention-deficit/hyperactivity disorder. *Neuropsychology*, *18*(3), 543-555.
- Frazier-Wood, A. C., Bralten, J., Arias-Vasquez, A., Luman, M., Oosterlaan, J., Sergeant, J., et al. (2012). Neuropsychological intra-individual variability explains unique genetic variance of ADHD and shows suggestive linkage to chromosomes 12, 13, and 17. *Am J Med Genet B Neuropsychiatr Genet*, *159B*(2), 131-140.
- Froehlich, T. E., Lanphear, B. P., Epstein, J. N., Barbaresi, W. J., Katusic, S. K., & Kahn, R. S. (2007). Prevalence, recognition, and treatment of attention-deficit/hyperactivity disorder in a national sample of US children. *Arch Pediatr Adolesc Med*, *161*(9), 857-864.
- Gaub, M., & Carlson, C. L. (1997). Gender differences in ADHD: a meta-analysis and critical review. *J Am Acad Child Adolesc Psychiatry*, *36*(8), 1036-1045.
- Gayán, J., & Olson, R. K. (2003). Genetic and environmental influences on individual differences in printed word recognition. *J Exp Child Psychol*, *84*(2), 97-123.
- Gevensleben, H., Holl, B., Albrecht, B., Vogel, C., Schlamp, D., Kratz, O., et al. (2009). Is neurofeedback an efficacious treatment for ADHD? A randomised controlled clinical trial. *J Child Psychol Psychiatry*, *50*(7), 780-789.
- Gilger, J. W., Pennington, B. F., & DeFries, J. C. (1992). A twin study of the etiology of comorbidity: attention-deficit hyperactivity disorder and dyslexia. *J Am Acad Child Adolesc Psychiatry*, *31*(2), 343-348.
- Gittelman, R., Mannuzza, S., Shenker, R., & Bonagura, N. (1985). Hyperactive boys almost grown up. I. Psychiatric status. *Arch Gen Psychiatry*, *42*(10), 937-947.
- Gizer, I. R., Ficks, C., & Waldman, I. D. (2009). Candidate gene studies of ADHD: a meta-analytic review. *Hum Genet*, *126*(1), 51-90.
- Gjone, H., Stevenson, J., & Sundet, J. M. (1996). Genetic influence on parent-reported attention-related problems in a Norwegian general population twin sample. *J Am Acad Child Adolesc Psychiatry*, *35*(5), 588-596; discussion 596-588.

- Glessner, J. T., Wang, K., Cai, G., Korvatska, O., Kim, C. E., Wood, S., et al. (2009). Autism genome-wide copy number variation reveals ubiquitin and neuronal genes. *Nature*, *459*(7246), 569-573.
- Goodman, R. (1997). The Strengths and Difficulties Questionnaire: a research note. *J Child Psychol Psychiatry*, *38*(5), 581-586.
- Goodman, R., Meltzer, H., & Bailey, V. (1998). The Strengths and Difficulties Questionnaire: a pilot study on the validity of the self-report version. *Eur Child Adolesc Psychiatry*, *7*(3), 125-130.
- Goodman, R., Simonoff, E., & Stevenson, J. (1995). The impact of child IQ, parent IQ and sibling IQ on child behavioural deviance scores. *J Child Psychol Psychiatry*, *36*(3), 409-425.
- Gottesman, II, & Gould, T. D. (2003). The endophenotype concept in psychiatry: etymology and strategic intentions. *Am J Psychiatry*, *160*(4), 636-645.
- Graetz, B. W., Sawyer, M. G., Hazell, P. L., Arney, F., & Baghurst, P. (2001). Validity of DSM-IVADHD subtypes in a nationally representative sample of Australian children and adolescents. *J Am Acad Child Adolesc Psychiatry*, *40*(12), 1410-1417.
- Greven, C. U., Asherson, P., Rijdsdijk, F. V., & Plomin, R. (2011a). A longitudinal twin study on the association between inattentive and hyperactive-impulsive ADHD symptoms. *J Abnorm Child Psychol*, *39*(5), 623-632.
- Greven, C. U., Harlaar, N., Dale, P. S., & Plomin, R. (2011b). Genetic Overlap between ADHD Symptoms and Reading is largely Driven by Inattentiveness rather than Hyperactivity-Impulsivity. *J Can Acad Child Adolesc Psychiatry*, *20*(1), 6-14.
- Greven, C. U., Rijdsdijk, F. V., & Plomin, R. (2011c). A twin study of ADHD symptoms in early adolescence: hyperactivity-impulsivity and inattentiveness show substantial genetic overlap but also genetic specificity. *J Abnorm Child Psychol*, *39*(2), 265-275.
- Groom, M. J., Scerif, G., Liddle, P. F., Batty, M. J., Liddle, E. B., Roberts, K. L., et al. (2010). Effects of motivation and medication on electrophysiological markers of response inhibition in children with attention-deficit/hyperactivity disorder. *Biol Psychiatry*, *67*(7), 624-631.
- Groth-Marnat, G. (1984). *Handbook of psychological assessment* (3rd ed.). NY: Wiley.
- Grozeva, D., Conrad, D. F., Barnes, C. P., Hurles, M., Owen, M. J., O'Donovan, M. C., et al. (2012). Independent estimation of the frequency of rare CNVs in the UK population confirms their role in schizophrenia. *Schizophr Res*, *135*(1-3), 1-7.

- Halperin, J. M., & Schulz, K. P. (2006). Revisiting the role of the prefrontal cortex in the pathophysiology of attention-deficit/hyperactivity disorder. *Psychol Bull*, *132*(4), 560-581.
- Halperin, J. M., Trampush, J. W., Miller, C. J., Marks, D. J., & Newcorn, J. H. (2008). Neuropsychological outcome in adolescents/young adults with childhood ADHD: profiles of persisters, remitters and controls. *J Child Psychol Psychiatry*, *49*(9), 958-966.
- Handen, B. L., Janosky, J., & McAuliffe, S. (1997). Long-term follow-up of children with mental retardation/borderline intellectual functioning and ADHD. *J Abnorm Child Psychol*, *25*(4), 287-295.
- Harlaar, N., Dale, P. S., & Plomin, R. (2007). From learning to read to reading to learn: substantial and stable genetic influence. *Child Dev*, *78*(1), 116-131.
- Harlaar, N., Spinath, F. M., Dale, P. S., & Plomin, R. (2005). Genetic influences on early word recognition abilities and disabilities: a study of 7-year-old twins. *J Child Psychol Psychiatry*, *46*(4), 373-384.
- Hart, E. L., Lahey, B. B., Loeber, R., Applegate, B., & Frick, P. J. (1995). Developmental change in attention-deficit hyperactivity disorder in boys: a four-year longitudinal study. *J Abnorm Child Psychol*, *23*(6), 729-749.
- Hartman, C. A., Rhee, S. H., Willcutt, E. G., & Pennington, B. F. (2007). Modeling rater disagreement for ADHD: are parents or teachers biased? *J Abnorm Child Psychol*, *35*(4), 536-542.
- Haworth, C. M., Kovas, Y., Harlaar, N., Hayiou-Thomas, M. E., Petrill, S. A., Dale, P. S., et al. (2009). Generalist genes and learning disabilities: a multivariate genetic analysis of low performance in reading, mathematics, language and general cognitive ability in a sample of 8000 12-year-old twins. *J Child Psychol Psychiatry*, *50*(10), 1318-1325.
- Haworth, C. M., Meaburn, E. L., Harlaar, N., & Plomin, R. (2007). Reading and Generalist Genes. *Mind Brain Educ*, *1*(4), 173-180.
- Haworth, K. E., Farrell, W. E., Emes, R. D., Ismail, K. M., Carroll, W. D., Borthwick, H. A., et al. (2013). Combined influence of gene-specific cord blood methylation and maternal smoking habit on birth weight. *Epigenomics*, *5*(1), 37-49.
- Heinrich, H., Gevensleben, H., Freisleder, F. J., Moll, G. H., & Rothenberger, A. (2004). Training of slow cortical potentials in attention-deficit/hyperactivity disorder: evidence for positive behavioral and neurophysiological effects. *Biol Psychiatry*, *55*(7), 772-775.

- Heinrich, H., Gevensleben, H., & Strehl, U. (2007). Annotation: neurofeedback - train your brain to train behaviour. *J Child Psychol Psychiatry*, *48*(1), 3-16.
- Helps, S., James, C., Debener, S., Karl, A., & Sonuga-Barke, E. J. (2008). Very low frequency EEG oscillations and the resting brain in young adults: a preliminary study of localisation, stability and association with symptoms of inattention. *J Neural Transm*, *115*(2), 279-285.
- Hermens, D. F., Kohn, M. R., Clarke, S. D., Gordon, E., & Williams, L. M. (2005). Sex differences in adolescent ADHD: findings from concurrent EEG and EDA. *Clin Neurophysiol*, *116*(6), 1455-1463.
- Hervey, A. S., Epstein, J. N., & Curry, J. F. (2004). Neuropsychology of adults with attention-deficit/hyperactivity disorder: a meta-analytic review. *Neuropsychology*, *18*(3), 485-503.
- Hill, J. C., & Schoener, E. P. (1996). Age-dependent decline of attention deficit hyperactivity disorder. *Am J Psychiatry*, *153*(9), 1143-1146.
- Hinshaw, S. P. (1992). Externalizing behavior problems and academic underachievement in childhood and adolescence: causal relationships and underlying mechanisms. *Psychol Bull*, *111*(1), 127-155.
- Hoffmann, H. (1985). *Lebenserinnerungen*. In: Herzog CH, Siefert H (eds) *Gesammelte Werke*. Main. . Frankfurt.
- Huang-Pollock, C. L., Karalunas, S. L., Tam, H., & Moore, A. N. (2012). Evaluating vigilance deficits in ADHD: a meta-analysis of CPT performance. *J Abnorm Psychol*, *121*(2), 360-371.
- Hudspeth, W. J., & Pribram, K. H. (1992). Psychophysiological indices of cerebral maturation. *Int J Psychophysiol*, *12*(1), 19-29.
- Hudziak, J. J., Derks, E. M., Althoff, R. R., Rettew, D. C., & Boomsma, D. I. (2005). The genetic and environmental contributions to attention deficit hyperactivity disorder as measured by the Conners' Rating Scales--Revised. *Am J Psychiatry*, *162*(9), 1614-1620.
- Ilott, N., Saudino, K. J., Wood, A., & Asherson, P. (2010). A genetic study of ADHD and activity level in infancy. *Genes Brain Behav*, *9*(3), 296-304.
- Inoue, K., Nadaoka, T., Oiji, A., Morioka, Y., Totsuka, S., Kanbayashi, Y., et al. (1998). Clinical evaluation of attention-deficit hyperactivity disorder by objective quantitative measures. *Child Psychiatry Hum Dev*, *28*(3), 179-188.
- Jensen, O., & Tesche, C. D. (2002). Frontal theta activity in humans increases with memory load in a working memory task. *Eur J Neurosci*, *15*(8), 1395-1399.

- Jensen, P. S., Arnold, L. E., Swanson, J. M., Vitiello, B., Abikoff, H. B., Greenhill, L. L., et al. (2007). 3-year follow-up of the NIMH MTA study. *J Am Acad Child Adolesc Psychiatry, 46*(8), 989-1002.
- Johnson, K. A., Kelly, S. P., Bellgrove, M. A., Barry, E., Cox, M., Gill, M., et al. (2007a). Response variability in attention deficit hyperactivity disorder: evidence for neuropsychological heterogeneity. *Neuropsychologia, 45*(4), 630-638.
- Johnson, K. A., Robertson, I. H., Kelly, S. P., Silk, T. J., Barry, E., Daibhis, A., et al. (2007b). Dissociation in performance of children with ADHD and high-functioning autism on a task of sustained attention. *Neuropsychologia, 45*(10), 2234-2245.
- Johnstone, S. J., Barry, R. J., & Clarke, A. R. (2013). Ten years on: a follow-up review of ERP research in attention-deficit/hyperactivity disorder. *Clin Neurophysiol, 124*(4), 644-657.
- Johnstone, S. J., & Clarke, A. R. (2009). Dysfunctional response preparation and inhibition during a visual Go/No-go task in children with two subtypes of attention-deficit hyperactivity disorder. *Psychiatry Res, 166*(2-3), 223-237.
- Jung, T. P., Makeig, S., Humphries, C., Lee, T. W., McKeown, M. J., Iragui, V., et al. (2000). Removing electroencephalographic artifacts by blind source separation. *Psychophysiology, 37*(2), 163-178.
- Kalff, A. C., De Sonneville, L. M., Hurks, P. P., Hendriksen, J. G., Kroes, M., Feron, F. J., et al. (2005). Speed, speed variability, and accuracy of information processing in 5 to 6-year-old children at risk of ADHD. *J Int Neuropsychol Soc, 11*(2), 173-183.
- Kalff, A. C., Hendriksen, J. G., Kroes, M., Vles, J. S., Steyaert, J., Feron, F. J., et al. (2002). Neurocognitive performance of 5- and 6-year-old children who met criteria for attention deficit/hyperactivity disorder at 18 months follow-up: results from a prospective population study. *J Abnorm Child Psychol, 30*(6), 589-598.
- Keage, H. A., Clark, C. R., Hermens, D. F., Williams, L. M., Kohn, M. R., Clarke, S., et al. (2008). ERP indices of working memory updating in AD/HD: differential aspects of development, subtype, and medication. *J Clin Neurophysiol, 25*(1), 32-41.
- Kendler, K. S., & Neale, M. C. (2010). Endophenotype: a conceptual analysis. *Mol Psychiatry, 15*(8), 789-797.
- Keulers, E. H., Hendriksen, J. G., Feron, F. J., Wassenberg, R., Wuisman-Frerker, M. G., Jolles, J., et al. (2007). Methylphenidate improves reading performance in children with attention deficit hyperactivity disorder and comorbid dyslexia: an unblinded clinical trial. *Eur J Paediatr Neurol, 11*(1), 21-28.

- Kishiyama, M. M., Boyce, W. T., Jimenez, A. M., Perry, L. M., & Knight, R. T. (2009). Socioeconomic disparities affect prefrontal function in children. *J Cogn Neurosci*, *21*(6), 1106-1115.
- Klein, C., Wendling, K., Huettner, P., Ruder, H., & Peper, M. (2006). Intra-subject variability in attention-deficit hyperactivity disorder. *Biol Psychiatry*, *60*(10), 1088-1097.
- Klimesch, W. (1999). EEG alpha and theta oscillations reflect cognitive and memory performance: a review and analysis. *Brain Res Brain Res Rev*, *29*(2-3), 169-195.
- Knopik, V. S., Maccani, M. A., Francazio, S., & McGeary, J. E. (2012). The epigenetics of maternal cigarette smoking during pregnancy and effects on child development. *Dev Psychopathol*, *24*(4), 1377-1390.
- Koenig, T., & Gianotti, L. R. R. (2009). *Scalp field maps and their characterization*. In *Electrical neuroimaging (Michel, C. M., Koenig, T., Brandeis, D., Gianotti, L. R. R., Wackemann, J. eds)*. Cambridge: Cambridge University Press.
- Kofler, M. J., Rapport, M. D., Sarver, D. E., Raiker, J. S., Orban, S. A., Friedman, L. M., et al. (2013). Reaction time variability in ADHD: A meta-analytic review of 319 studies. *Clin Psychol Rev*, *33*(6), 795-811.
- Kooij, J. J. S., & Francken, M. H. (Producer). (2007) Diagnostic Interview for ADHD (DIVA) in adults. retrieved from Downloaded via www.divacentre.eu.
- Kuntsi, J., Andreou, P., Ma, J., Borger, N. A., & van der Meere, J. J. (2005a). Testing assumptions for endophenotype studies in ADHD: reliability and validity of tasks in a general population sample. *BMC Psychiatry*, *5*, 40.
- Kuntsi, J., Eley, T. C., Taylor, A., Hughes, C., Asherson, P., Caspi, A., et al. (2004a). Co-occurrence of ADHD and low IQ has genetic origins. *American Journal of Medical Genetics*, *124B*(1), 41-47.
- Kuntsi, J., Eley, T. C., Taylor, A., Hughes, C., Asherson, P., Caspi, A., et al. (2004b). Co-occurrence of ADHD and low IQ has genetic origins. *Am J Med Genet B Neuropsychiatr Genet*, *124B*(1), 41-47.
- Kuntsi, J., Frazier-Wood, A. C., Banaschewski, T., Gill, M., Miranda, A., Oades, R. D., et al. (2012). Genetic analysis of reaction time variability: room for improvement? *Psychol Med*, 1-11.
- Kuntsi, J., & Klein, C. (2012). Intraindividual variability in ADHD and its implications for research of causal links. *Curr Top Behav Neurosci*, *9*, 67-91.

- Kuntsi, J., Neale, B. M., Chen, W., Faraone, S. V., & Asherson, P. (2006a). The IMAGE project: methodological issues for the molecular genetic analysis of ADHD. *Behav Brain Funct*, *2*, 27.
- Kuntsi, J., Pinto, R., Price, T. S., van der Meere, J. J., Frazier-Wood, A. C., & Asherson, P. (2013). The Separation of ADHD Inattention and Hyperactivity-Impulsivity Symptoms: Pathways from Genetic Effects to Cognitive Impairments and Symptoms. *J Abnorm Child Psychol*.
- Kuntsi, J., Rijdsdijk, F., Ronald, A., Asherson, P., & Plomin, R. (2005b). Genetic influences on the stability of attention-deficit/hyperactivity disorder symptoms from early to middle childhood. *Biol Psychiatry*, *57*(6), 647-654.
- Kuntsi, J., Rogers, H., Swinard, G., Borger, N., van der Meere, J., Rijdsdijk, F., et al. (2006b). Reaction time, inhibition, working memory and 'delay aversion' performance: genetic influences and their interpretation. *Psychol Med*, *36*(11), 1613-1624.
- Kuntsi, J., & Stevenson, J. (2000). Hyperactivity in children: a focus on genetic research and psychological theories. *Clin Child Fam Psychol Rev*, *3*(1), 1-23.
- Kuntsi, J., & Stevenson, J. (2001). Psychological mechanisms in hyperactivity: II. The role of genetic factors. *J Child Psychol Psychiatry*, *42*(2), 211-219.
- Kuntsi, J., Wood, A. C., Rijdsdijk, F., Johnson, K. A., Andreou, P., Albrecht, B., et al. (2010). Separation of cognitive impairments in attention-deficit/hyperactivity disorder into 2 familial factors. *Arch Gen Psychiatry*, *67*(11), 1159-1167.
- Kuntsi, J., Wood, A. C., Van Der Meere, J., & Asherson, P. (2009). Why cognitive performance in ADHD may not reveal true potential: findings from a large population-based sample. *J Int Neuropsychol Soc*, *15*(4), 570-579.
- Kuperman, S., Johnson, B., Arndt, S., Lindgren, S., & Wolraich, M. (1996). Quantitative EEG differences in a nonclinical sample of children with ADHD and undifferentiated ADD. *J Am Acad Child Adolesc Psychiatry*, *35*(8), 1009-1017.
- Lahey, B. B., D'Onofrio, B. M., & Waldman, I. D. (2009). Using epidemiologic methods to test hypotheses regarding causal influences on child and adolescent mental disorders. *J Child Psychol Psychiatry*, *50*(1-2), 53-62.
- Lange, K. W., Reichl, S., Lange, K. M., Tucha, L., & Tucha, O. (2010). The history of attention deficit hyperactivity disorder. *Atten Defic Hyperact Disord*, *2*(4), 241-255.
- Langley, K., Fowler, T., Ford, T., Thapar, A. K., van den Bree, M., Harold, G., et al. (2010). Adolescent clinical outcomes for young people with attention-deficit hyperactivity disorder. *Br J Psychiatry*, *196*(3), 235-240.

- Lara, C., Fayyad, J., de Graaf, R., Kessler, R. C., Aguilar-Gaxiola, S., Angermeyer, M., et al. (2009). Childhood predictors of adult attention-deficit/hyperactivity disorder: results from the World Health Organization World Mental Health Survey Initiative. *Biol Psychiatry*, *65*(1), 46-54.
- Larson, K., Russ, S. A., Kahn, R. S., & Halfon, N. (2011). Patterns of comorbidity, functioning, and service use for US children with ADHD, 2007. *Pediatrics*, *127*(3), 462-470.
- Larsson, H., Anckarsater, H., Rastam, M., Chang, Z., & Lichtenstein, P. (2012). Childhood attention-deficit hyperactivity disorder as an extreme of a continuous trait: a quantitative genetic study of 8,500 twin pairs. *J Child Psychol Psychiatry*, *53*(1), 73-80.
- Larsson, H., Lichtenstein, P., & Larsson, J. O. (2006). Genetic contributions to the development of ADHD subtypes from childhood to adolescence. *J Am Acad Child Adolesc Psychiatry*, *45*(8), 973-981.
- Larsson, J. O., Larsson, H., & Lichtenstein, P. (2004). Genetic and environmental contributions to stability and change of ADHD symptoms between 8 and 13 years of age: a longitudinal twin study. *J Am Acad Child Adolesc Psychiatry*, *43*(10), 1267-1275.
- Lazzaro, I., Gordon, E., Li, W., Lim, C. L., Plahn, M., Whitmont, S., et al. (1999). Simultaneous EEG and EDA measures in adolescent attention deficit hyperactivity disorder. *Int J Psychophysiol*, *34*(2), 123-134.
- Leek, J. T., & Storey, J. D. (2008). A general framework for multiple testing dependence. *Proc Natl Acad Sci U S A*, *105*(48), 18718-18723.
- Levy, F., Hay, D. A., McStephen, M., Wood, C., & Waldman, I. (1997). Attention-deficit hyperactivity disorder: a category or a continuum? Genetic analysis of a large-scale twin study. *J Am Acad Child Adolesc Psychiatry*, *36*(6), 737-744.
- Light, J., Pennington, B., Gilger, J. W., & DeFries, J. C. (1995). Reading disability and hyperactivity disorder: evidence for a common genetic etiology. *Developmental Neuropsychology*, *11*(3), 323-335.
- Linnet, K. M., Dalsgaard, S., Obel, C., Wisborg, K., Henriksen, T. B., Rodriguez, A., et al. (2003). Maternal lifestyle factors in pregnancy risk of attention deficit hyperactivity disorder and associated behaviors: review of the current evidence. *Am J Psychiatry*, *160*(6), 1028-1040.

- Liotti, M., Pliszka, S. R., Higgins, K., Perez, R., 3rd, & Semrud-Clikeman, M. (2010). Evidence for specificity of ERP abnormalities during response inhibition in ADHD children: a comparison with reading disorder children without ADHD. *Brain Cogn*, 72(2), 228-237.
- Loehlin, J. C. (1996). The Cholesky Approach: a cautionary note. *Behavior Genetics*, 26(1), 65-69.
- Loney, J., Kramer, J., & Millich, R. S. (1981). *The hyperactive child grows up: predictors of symptoms, delinquency and achievement at follow-up*. In: Gadow KS, Loney, J, editors. *Psychosocial aspects of drug treatment for hyperactivity*. Boulder: CO: Westview Press.
- Loo, S. K. (2011). Identifying Biomarkers for ADHD Remission: . *The ADHD report*, 19(3), 6-9.
- Loo, S. K., Hale, T. S., Macion, J., Hanada, G., McGough, J. J., McCracken, J. T., et al. (2009). Cortical activity patterns in ADHD during arousal, activation and sustained attention. *Neuropsychologia*, 47(10), 2114-2119.
- Loo, S. K., Hopfer, C., Teale, P. D., & Reite, M. L. (2004). EEG correlates of methylphenidate response in ADHD: association with cognitive and behavioral measures. *J Clin Neurophysiol*, 21(6), 457-464.
- Loo, S. K., & Smalley, S. L. (2008). Preliminary report of familial clustering of EEG measures in ADHD. *Am J Med Genet B Neuropsychiatr Genet*, 147B(1), 107-109.
- Luck, S. J. (2005). *An introduction to the event-related potential technique*. Cambridge, Massachusetts: MIT Press.
- Mannuzza, S., Klein, R. G., & Addalli, K. A. (1991). Young adult mental status of hyperactive boys and their brothers: a prospective follow-up study. *J Am Acad Child Adolesc Psychiatry*, 30(5), 743-751.
- Mannuzza, S., Klein, R. G., Bessler, A., Malloy, P., & LaPadula, M. (1993). Adult outcome of hyperactive boys. Educational achievement, occupational rank, and psychiatric status. *Arch Gen Psychiatry*, 50(7), 565-576.
- Mariani, M. A., & Barkley, R. A. (1997). Neuropsychological and academic functioning in preschool boys with attention deficit hyperactivity disorder. *Dev Neuropsychol*, 13, 111-129.
- Martin, N., Scourfield, J., & McGuffin, P. (2002). Observer effects and heritability of childhood attention-deficit hyperactivity disorder symptoms. *Br J Psychiatry*, 180, 260-265.

- Martin, N. C., Levy, F., Pieka, J., & Hay, D. (2006). A genetic study of Attention Deficit Hyperactivity Disorder, Conduct Disorder, Oppositional Defiant Disorder and Reading Disability: Aetiological overlaps and implications. *International Journal of Disability, Development and Education*, 53, 21-34.
- Martinussen, R., Hayden, J., Hogg-Johnson, S., & Tannock, R. (2005). A meta-analysis of working memory impairments in children with attention-deficit/hyperactivity disorder. *J Am Acad Child Adolesc Psychiatry*, 44(4), 377-384.
- Marzocchi, G. M., Oosterlaa, J., Zuddas, A., Cavolina, P., Geurts, H., Redigolo, D., et al. (2008). Contrasting deficits on executive functions between ADHD and reading disabled children. *Journal of Child Psychology and Psychiatry*, 49(5), 543-552.
- Matson, J. L., Rieske, R. D., & Williams, L. W. (2013). The relationship between autism spectrum disorders and attention-deficit/hyperactivity disorder: An overview. *Res Dev Disabil*, 34(9), 2475-2484.
- McGrath, A. M., Handwerk, M. L., Armstrong, K. J., Lucas, C. P., & Friman, P. C. (2004). The validity of the ADHD section of the Diagnostic Interview Schedule for Children. *Behav Modif*, 28(3), 349-374.
- McGrath, L. M., Pennington, B. F., Shanahan, M. A., Santerre-Lemmon, L. E., Barnard, H. D., Willcutt, E. G., et al. (2010). A multiple deficit model of reading disability and attention-deficit/hyperactivity disorder: searching for shared cognitive deficits. *J Child Psychol Psychiatry*.
- McGrath, L. M., Pennington, B. F., Shanahan, M. A., Santerre-Lemmon, L. E., Barnard, H. D., Willcutt, E. G., et al. (2011). A multiple deficit model of reading disability and attention-deficit/hyperactivity disorder: searching for shared cognitive deficits. *J Child Psychol Psychiatry*, 52(5), 547-557.
- McLoughlin, G., Albrecht, B., Banaschewski, T., Rothenberger, A., Brandeis, D., Asherson, P., et al. (2009). Performance monitoring is altered in adult ADHD: a familial event-related potential investigation. *Neuropsychologia*, 47(14), 3134-3142.
- McLoughlin, G., Albrecht, B., Banaschewski, T., Rothenberger, A., Brandeis, D., Asherson, P., et al. (2010). Electrophysiological evidence for abnormal preparatory states and inhibitory processing in adult ADHD. *Behav Brain Funct*, 6, 66.
- McLoughlin, G., Asherson, P., Albrecht, B., Banaschewski, T., Rothenberger, A., Brandeis, D., et al. (2011). Cognitive-electrophysiological indices of attentional and inhibitory processing in adults with ADHD: familial effects. *Behav Brain Funct*, 7, 26.

- McLoughlin, G., Ronald, A., Kuntsi, J., Asherson, P., & Plomin, R. (2007). Genetic support for the dual nature of attention deficit hyperactivity disorder: substantial genetic overlap between the inattentive and hyperactive-impulsive components. *J Abnorm Child Psychol*, *35*(6), 999-1008.
- Merwood, A., Greven, C. U., Price, T. S., Rijdsdijk, F., Kuntsi, J., McLoughlin, G., et al. (2013). Different heritabilities but shared etiological influences for parent, teacher and self-ratings of ADHD symptoms: an adolescent twin study. *Psychol Med*, 1-12.
- Metin, B., Roeyers, H., Wiersema, J. R., van der Meere, J., & Sonuga-Barke, E. (2012). A meta-analytic study of event rate effects on Go/No-Go performance in attention-deficit/hyperactivity disorder. *Biol Psychiatry*, *72*(12), 990-996.
- Michels, L., Muthuraman, M., Luchinger, R., Martin, E., Anwar, A. R., Raethjen, J., et al. (2013). Developmental changes of functional and directed resting-state connectivities associated with neuronal oscillations in EEG. *Neuroimage*, *81*, 231-242.
- Mill, J., & Petronis, A. (2008). Pre- and peri-natal environmental risks for attention-deficit hyperactivity disorder (ADHD): the potential role of epigenetic processes in mediating susceptibility. *J Child Psychol Psychiatry*, *49*(10), 1020-1030.
- Miller, G. A., & Chapman, J. P. (2001). Misunderstanding analysis of covariance. *J Abnorm Psychol*, *110*(1), 40-48.
- Mitsis, E. M., McKay, K. E., Schulz, K. P., Newcorn, J. H., & Halperin, J. M. (2000). Parent-teacher concordance for DSM-IV attention-deficit/hyperactivity disorder in a clinic-referred sample. *J Am Acad Child Adolesc Psychiatry*, *39*(3), 308-313.
- Molina, B. S., Hinshaw, S. P., Swanson, J. M., Arnold, L. E., Vitiello, B., Jensen, P. S., et al. (2009). The MTA at 8 years: prospective follow-up of children treated for combined-type ADHD in a multisite study. *J Am Acad Child Adolesc Psychiatry*, *48*(5), 484-500.
- Moriyama, T. S., Polanczyk, G. V., Terzi, F. S., Faria, K. M., & Rohde, L. A. (2013). Psychopharmacology and psychotherapy for the treatment of adults with ADHD-a systematic review of available meta-analyses. *CNS Spectr*, 1-11.
- Nadder, T. S., Rutter, M., Silberg, J. L., Maes, H. H., & Eaves, L. J. (2002). Genetic effects on the variation and covariation of attention deficit-hyperactivity disorder (ADHD) and oppositional-defiant disorder/conduct disorder (Odd/CD) symptomatologies across informant and occasion of measurement. *Psychol Med*, *32*(1), 39-53.

- Nadder, T. S., Silberg, J. L., Rutter, M., Maes, H. H., & Eaves, L. J. (2001). Comparison of multiple measures of ADHD symptomatology: a multivariate genetic analysis. *J Child Psychol Psychiatry*, *42*(4), 475-486.
- National Institute of Health and Clinical Excellence (NICE). (2008). *Attention deficit hyperactivity disorder: Diagnosis and management of ADHD in children, young people and adults*.
- Nazari, M. A., Wallois, F., Aarabi, A., & Berquin, P. (2011). Dynamic changes in quantitative electroencephalogram during continuous performance test in children with attention-deficit/hyperactivity disorder. *Int J Psychophysiol*, *81*(3), 230-236.
- Neale, M. C., Boker, S. M., Xie, G., & Maes, H. (2006a). *Statistical Modelling* (7th ed.) VCU Box 900126, Richmond, VA 23298: Department of Psychiatry.
- Neale, M. C., & Cardon, L. (1992). *Methodology for genetic studies of twin and families*. Dordrech (Netherlands): Kluwer.
- Neale, M. C., Eaves, L. J., & Kendler, K. S. (1994). The power of the classical twin study to resolve variation in threshold traits. *Behav Genet*, *24*(3), 239-258.
- Neale, M. C., Roysamb, E., & Jacobson, K. (2006b). Multivariate genetic analysis of sex limitation and G x E interaction. *Twin Res Hum Genet*, *9*(4), 481-489.
- Newcorn, J. H., Halperin, J. M., Jensen, P. S., Abikoff, H. B., Arnold, L. E., Cantwell, D. P., et al. (2001). Symptom profiles in children with ADHD: effects of comorbidity and gender. *J Am Acad Child Adolesc Psychiatry*, *40*(2), 137-146.
- Newcorn, J. H., Halperin, J. M., Schwartz, S., Pascualvaca, D., Wolf, L., Schmeidler, J., et al. (1994). Parent and teacher ratings of attention-deficit hyperactivity disorder symptoms: implications for case identification. *J Dev Behav Pediatr*, *15*(2), 86-91.
- Nieuwenhuis, S., Yeung, N., van den Wildenberg, W., & Ridderinkhof, K. R. (2003). Electrophysiological correlates of anterior cingulate function in a go/no-go task: effects of response conflict and trial type frequency. *Cogn Affect Behav Neurosci*, *3*(1), 17-26.
- Nigg, J. T., Blaskey, L. G., Stawicki, J. A., & Sachek, J. (2004). Evaluating the endophenotype model of ADHD neuropsychological deficit: results for parents and siblings of children with ADHD combined and inattentive subtypes. *J Abnorm Psychol*, *113*(4), 614-625.
- Nigg, J. T., & Casey, B. J. (2005). An integrative theory of attention-deficit/ hyperactivity disorder based on the cognitive and affective neurosciences. *Dev Psychopathol*, *17*(3), 785-806.

- Nikolas, M. A., & Burt, S. A. (2010). Genetic and environmental influences on ADHD symptom dimensions of inattention and hyperactivity: a meta-analysis. *J Abnorm Psychol, 119*(1), 1-17.
- Nolan, E. E., Gadow, K. D., & Sprafkin, J. (2001). Teacher reports of DSM-IV ADHD, ODD, and CD symptoms in schoolchildren. *J Am Acad Child Adolesc Psychiatry, 40*(2), 241-249.
- O'Connell, R. G., Bellgrove, M. A., Dockree, P. M., Lau, A., Fitzgerald, M., & Robertson, I. H. (2008). Self-Alert Training: volitional modulation of autonomic arousal improves sustained attention. *Neuropsychologia, 46*(5), 1379-1390.
- O'Connell, R. G., Dockree, P. M., Bellgrove, M. A., Turin, A., Ward, S., Foxe, J. J., et al. (2009a). Two types of action error: electrophysiological evidence for separable inhibitory and sustained attention neural mechanisms producing error on go/no-go tasks. *J Cogn Neurosci, 21*(1), 93-104.
- O'Connell, R. G., Dockree, P. M., Robertson, I. H., Bellgrove, M. A., Foxe, J. J., & Kelly, S. P. (2009b). Uncovering the neural signature of lapsing attention: electrophysiological signals predict errors up to 20 s before they occur. *J Neurosci, 29*(26), 8604-8611.
- Oddy, B., Barry, R. J., Johnstone, S. J., & Clarke, A. R. (2005). Removal of CNV effects from the N2 and P3 ERP components in a visual Go/NoGo Task. *Journal of Psychophysiology, 19*(1), 24-34.
- Overtom, C. C., Bekker, E. M., van der Molen, M. W., Verbaten, M. N., Kooij, J. J., Buitelaar, J. K., et al. (2009). Methylphenidate restores link between stop-signal sensory impact and successful stopping in adults with attention-deficit/hyperactivity disorder. *Biol Psychiatry, 65*(7), 614-619.
- Owens, E. B., Hinshaw, S. P., Kraemer, H. C., Arnold, L. E., Abikoff, H. B., Cantwell, D. P., et al. (2003). Which treatment for whom for ADHD? Moderators of treatment response in the MTA. *J Consult Clin Psychol, 71*(3), 540-552.
- Palmer, E., & Finger, S. (2001). An early description of ADHD (Inattentive Subtype): Dr Alexander Crichton and 'Mental Restlessness' (1798). *Child Psychol Psychiatry Rev, 6*, 66-73.
- Paloyelis, Y., Asherson, P., & Kuntsi, J. (2009). Are ADHD symptoms associated with delay aversion or choice impulsivity? A general population study. *J Am Acad Child Adolesc Psychiatry, 48*(8), 837-846.

- Paloyelis, Y., Rijdsdijk, F., Wood, A. C., Asherson, P., & Kuntsi, J. (2010). The genetic association between ADHD symptoms and reading difficulties: the role of inattentiveness and IQ. *J Abnorm Child Psychol*, *38*(8), 1083-1095.
- Pastor, P. N., & Reuben, C. A. (2008). Diagnosed attention deficit hyperactivity disorder and learning disability: United States, 2004-2006. *Vital Health Stat* *10*(237), 1-14.
- Pennington, B., Groisser, D., & Welsh, M. C. (1993a). Contrasting cognitive deficits in Attention Deficit Hyperactivity Disorder versus Reading Disability. *Developmental Psychology*, *29*, 511-523.
- Pennington, B. F., Grossier, D., & Welsh, M. C. (1993b). Contrasting cognitive deficits in attention deficit hyperactivity disorder versus reading disability. *Developmental Psychology*, *29*, 511-523.
- Pineda, D., Ardila, A., Rosselli, M., Arias, B. E., Henao, G. C., Gomez, L. F., et al. (1999). Prevalence of attention-deficit/hyperactivity disorder symptoms in 4- to 17-year-old children in the general population. *J Abnorm Child Psychol*, *27*(6), 455-462.
- Pinquart, M., & Sorensen, S. (2000). Influences of socioeconomic status, social network, and competence on subjective well-being in later life: a meta-analysis. *Psychol Aging*, *15*(2), 187-224.
- Pliszka, S. R. (2007). Pharmacologic treatment of attention-deficit/hyperactivity disorder: efficacy, safety and mechanisms of action. *Neuropsychol Rev*, *17*(1), 61-72.
- Plomin, R., & Kovas, Y. (2005). Generalist genes and learning disabilities. *Psychol Bull*, *131*(4), 592-617.
- Polanczyk, G., de Lima, M. S., Horta, B. L., Biederman, J., & Rohde, L. A. (2007). The worldwide prevalence of ADHD: a systematic review and metaregression analysis. *Am J Psychiatry*, *164*(6), 942-948.
- Polderman, T. J., Derks, E. M., Hudziak, J. J., Verhulst, F. C., Posthuma, D., & Boomsma, D. I. (2007). Across the continuum of attention skills: a twin study of the SWAN ADHD rating scale. *J Child Psychol Psychiatry*, *48*(11), 1080-1087.
- Polderman, T. J., Gosso, M. F., Posthuma, D., Van Beijsterveldt, T. C., Heutink, P., Verhulst, F. C., et al. (2006). A longitudinal twin study on IQ, executive functioning, and attention problems during childhood and early adolescence. *Acta Neurol Belg*, *106*(4), 191-207.
- Polich, J. (2007). Updating P300: an integrative theory of P3a and P3b. *Clin Neurophysiol*, *118*(10), 2128-2148.

- Posthuma, D. (2009). Multivariate Genetic Analysis. In K. Yong-Kyu (Ed.). *Handbook of Behavior Genetics* (pp. 47-59). New York: Springer Science.
- Purvis, K. L., & Tannock, R. (2000). Phonological processing, not inhibitory control, differentiates ADHD and reading disability. *J Am Acad Child Adolesc Psychiatry*, 39(4), 485-494.
- Quinn, P. (2011). *Gender differences in ADHD. In: ADHD in adults: Characterization, diagnosis, and treatment*. Cambridge: Cambridge University Press.
- Rapport, M. D., Alderson, R. M., Kofler, M. J., Sarver, D. E., Bolden, J., & Sims, V. (2008). Working memory deficits in boys with attention-deficit/hyperactivity disorder (ADHD): the contribution of central executive and subsystem processes. *J Abnorm Child Psychol*, 36(6), 825-837.
- Rapport, M. D., Scanlan, S. W., & Denney, C. B. (1999). Attention-deficit/hyperactivity disorder and scholastic achievement: a model of dual developmental pathways. *J Child Psychol Psychiatry*, 40(8), 1169-1183.
- Rhodes, S. M., Coghill, D. R., & Matthews, K. (2006). Acute neuropsychological effects of methylphenidate in stimulant drug-naive boys with ADHD II--broader executive and non-executive domains. *J Child Psychol Psychiatry*, 47(11), 1184-1194.
- Rietveld, M. J., Hudziak, J. J., Bartels, M., van Beijsterveldt, C. E., & Boomsma, D. I. (2003). Heritability of attention problems in children: I. cross-sectional results from a study of twins, age 3-12 years. *Am J Med Genet B Neuropsychiatr Genet*, 117B(1), 102-113.
- Rietveld, M. J., Hudziak, J. J., Bartels, M., van Beijsterveldt, C. E., & Boomsma, D. I. (2004). Heritability of attention problems in children: longitudinal results from a study of twins, age 3 to 12. *J Child Psychol Psychiatry*, 45(3), 577-588.
- Rietveld, M. J., Posthuma, D., Dolan, C. V., & Boomsma, D. I. (2003a). ADHD: sibling interaction or dominance: an evaluation of statistical power. *Behav Genet*, 33(3), 247-255.
- Rietveld, M. J., Posthuma, I. D., Dolan, C. V., & Boomsma, D. I. (2003b). ADHD: sibling interaction or dominance: an evaluation of statistical power. *Behav Genet*, 33(3), 247-255.
- Rijsdijk, F. V., & Sham, P. C. (2002). Analytic approaches to twin data using structural equation models. *Brief Bioinform*, 3(2), 119-133.
- Rijsdijk, F. V., van Haren, N. E., Picchioni, M. M., McDonald, C., Touloupoulou, T., Hulshoff Pol, H. E., et al. (2005). Brain MRI abnormalities in schizophrenia: same genes or same environment? *Psychol Med*, 35(10), 1399-1409.

- Roberts, L. E., Rau, H., Lutzenberger, W., & Birbaumer, N. (1994). Mapping P300 waves onto inhibition: Go/No-Go discrimination. *Electroencephalogr Clin Neurophysiol*, 92(1), 44-55.
- Rommelse, N. N., Altink, M. E., Fliers, E. A., Martin, N. C., Buschgens, C. J., Hartman, C. A., et al. (2009). Comorbid problems in ADHD: degree of association, shared endophenotypes, and formation of distinct subtypes. Implications for a future DSM. *J Abnorm Child Psychol*, 37(6), 793-804.
- Rommelse, N. N., Altink, M. E., Martin, N. C., Buschgens, C. J., Buitelaar, J. K., Sergeant, J. A., et al. (2008a). Neuropsychological measures probably facilitate heritability research of ADHD. *Arch Clin Neuropsychol*, 23(5), 579-591.
- Rommelse, N. N., Altink, M. E., Oosterlaan, J., Buschgens, C. J., Buitelaar, J., & Sergeant, J. A. (2008b). Support for an independent familial segregation of executive and intelligence endophenotypes in ADHD families. *Psychol Med*, 38(11), 1595-1606.
- Rommelse, N. N., Arias-Vasquez, A., Altink, M. E., Buschgens, C. J., Fliers, E., Asherson, P., et al. (2008c). Neuropsychological endophenotype approach to genome-wide linkage analysis identifies susceptibility loci for ADHD on 2q21.1 and 13q12.11. *Am J Hum Genet*, 83(1), 99-105.
- Ronald, A., Simonoff, E., Kuntsi, J., Asherson, P., & Plomin, R. (2008). Evidence for overlapping genetic influences on autistic and ADHD behaviours in a community twin sample. *J Child Psychol Psychiatry*, 49(5), 535-542.
- Roodenrys, S., Koloski, N., & Grainger, J. (2001). Working memory function in attention deficit hyperactivity disorder and reading disabled children. *British Journal of Developmental Psychology*, 19, 325-337.
- Rosler, F., Heil, M., & Roder, B. (1997). Slow negative brain potentials as reflections of specific modular resources of cognition. *Biol Psychol*, 45(1-3), 109-141.
- Roth, T. L., Lubin, F. D., Funk, A. J., & Sweatt, J. D. (2009). Lasting epigenetic influence of early-life adversity on the BDNF gene. *Biol Psychiatry*, 65(9), 760-769.
- Rucklidge, J. J., & Tannock, R. (2001). Psychiatric, psychosocial, and cognitive functioning of female adolescents with ADHD. *J Am Acad Child Adolesc Psychiatry*, 40, 530-540.
- Rutter, M., Macdonald, H., Le Couteur, A., Harrington, R., Bolton, P., & Bailey, A. (1990). Genetic factors in child psychiatric disorders--II. Empirical findings. *J Child Psychol Psychiatry*, 31(1), 39-83.

- Rutter, M., Yule, B., Quinton, D., Rowlands, O., Yule, W., & Berger, M. (1975). Attainment and adjustment in two geographical areas: III--Some factors accounting for area differences. *Br J Psychiatry*, *126*, 520-533.
- Sagvolden, T., Johansen, E. B., Aase, H., & Russell, V. A. (2005). A dynamic developmental theory of attention-deficit/hyperactivity disorder (ADHD) predominantly hyperactive/impulsive and combined subtypes. *Behav Brain Sci*, *28*(3), 397-419; discussion 419-368.
- Sattler, J. M. (1992). *Assessment of Children: WISC-III and WPPSI-R Supplement*. San Diego: Jerome M. Sattler.
- Saudino, K. J., Cherny, S. S., & Plomin, R. (2000). Parent ratings of temperament in twins: explaining the 'too low' DZ correlations. *Twin Res*, *3*(4), 224-233.
- Saudino, K. J., Ronald, A., & Plomin, R. (2005). The etiology of behavior problems in 7-year-old twins: substantial genetic influence and negligible shared environmental influence for parent ratings and ratings by same and different teachers. *J Abnorm Child Psychol*, *33*(1), 113-130.
- Scheres, A., Lee, A., & Sumiya, M. (2008). Temporal reward discounting and ADHD: task and symptom specific effects. *J Neural Transm*, *115*(2), 221-226.
- Scheres, A., Oosterlaan, J., Swanson, J., Morein-Zamir, S., Meiran, N., Schut, H., et al. (2003). The effect of methylphenidate on three forms of response inhibition in boys with AD/HD. *J Abnorm Child Psychol*, *31*(1), 105-120.
- Schoechlin, C., & Engel, R. R. (2005). Neuropsychological performance in adult attention-deficit hyperactivity disorder: meta-analysis of empirical data. *Arch Clin Neuropsychol*, *20*(6), 727-744.
- Seidman, L. J. (2006). Neuropsychological functioning in people with ADHD across the lifespan. *Clin Psychol Rev*, *26*(4), 466-485.
- Seidman, L. J., Biederman, J., Monuteaux, M. C., Weber, W., & Faraone, S. V. (2000). Neuropsychological functioning in nonreferred siblings of children with attention deficit/hyperactivity disorder. *J Abnorm Psychol*, *109*(2), 252-265.
- Seifert, J., Scheuerpflug, P., Zillessen, K. E., Fallgatter, A., & Warnke, A. (2003). Electrophysiological investigation of the effectiveness of methylphenidate in children with and without ADHD. *J Neural Transm*, *110*(7), 821-829.
- Semrud-Clikeman, M., Biederman, J., Sprich-Buckminster, S., Lehman, B. K., Faraone, S. V., & Norman, D. (1992). Comorbidity between ADDH and learning disability: a review and report in a clinically referred sample. *J Am Acad Child Adolesc Psychiatry*, *31*(3), 439-448.

- Sergeant, J. A. (2005). Modeling attention-deficit/hyperactivity disorder: a critical appraisal of the cognitive-energetic model. *Biol Psychiatry*, *57*(11), 1248-1255.
- Sexton, C. C., Gelhorn, H. L., Bell, J. A., & Classi, P. M. (2012). The co-occurrence of reading disorder and ADHD: epidemiology, treatment, psychosocial impact, and economic burden. *J Learn Disabil*, *45*(6), 538-564.
- Shanahan, M. A., Pennington, B. F., Yerys, B. E., Scott, A., Boada, R., Willcutt, E. G., et al. (2006). Processing speed deficits in attention deficit/hyperactivity disorder and reading disability. *J Abnorm Child Psychol*, *34*(5), 585-602.
- Shaw, P., Eckstrand, K., Sharp, W., Blumenthal, J., Lerch, J. P., Greenstein, D., et al. (2007). Attention-deficit/hyperactivity disorder is characterized by a delay in cortical maturation. *Proc Natl Acad Sci U S A*, *104*(49), 19649-19654.
- Shaw, P., Lerch, J., Greenstein, D., Sharp, W., Clasen, L., Evans, A., et al. (2006). Longitudinal mapping of cortical thickness and clinical outcome in children and adolescents with attention-deficit/hyperactivity disorder. *Arch Gen Psychiatry*, *63*(5), 540-549.
- Shaywitz, S. E., Escobar, M. D., Shaywitz, B. A., Fletcher, J. M., & Makuch, R. (1992). Evidence that dyslexia may represent the lower tail of a normal distribution of reading ability. *N Engl J Med*, *326*(3), 145-150.
- Sherman, D. K., Iacono, W. G., & McGue, M. K. (1997). Attention-deficit hyperactivity disorder dimensions: a twin study of inattention and impulsivity-hyperactivity. *J Am Acad Child Adolesc Psychiatry*, *36*(6), 745-753.
- Sibley, M. H., Pelham, W. E., Molina, B. S., Gnagy, E. M., Waxmonsky, J. G., Waschbusch, D. A., et al. (2012). When diagnosing ADHD in young adults emphasize informant reports, DSM items, and impairment. *J Consult Clin Psychol*, *80*(6), 1052-1061.
- Simon, V., Czobor, P., Balint, S., Meszaros, A., & Bitter, I. (2009). Prevalence and correlates of adult attention-deficit hyperactivity disorder: meta-analysis. *Br J Psychiatry*, *194*(3), 204-211.
- Simonoff, E., Pickles, A., Hervas, A., Silberg, J. L., Rutter, M., & Eaves, L. (1998). Genetic influences on childhood hyperactivity: contrast effects imply parental rating bias, not sibling interaction. *Psychol Med*, *28*(4), 825-837.
- Simson, R., Vaughan, H. G., Jr., & Ritter, W. (1977). The scalp topography of potentials in auditory and visual Go/NoGo tasks. *Electroencephalogr Clin Neurophysiol*, *43*(6), 864-875.

- Slusarek, M., Velling, S., Bunk, D., & Eggers, C. (2001). Motivational effects on inhibitory control in children with ADHD. *J Am Acad Child Adolesc Psychiatry, 40*(3), 355-363.
- Snyder, S. M., & Hall, J. R. (2006). A meta-analysis of quantitative EEG power associated with attention-deficit hyperactivity disorder. *J Clin Neurophysiol, 23*(5), 440-455.
- Sonuga-Barke, E. J. (2002). Psychological heterogeneity in AD/HD--a dual pathway model of behaviour and cognition. *Behav Brain Res, 130*(1-2), 29-36.
- Sonuga-Barke, E. J., Brandeis, D., Cortese, S., Daley, D., Ferrin, M., Holtmann, M., et al. (2013). Nonpharmacological interventions for ADHD: systematic review and meta-analyses of randomized controlled trials of dietary and psychological treatments. *Am J Psychiatry, 170*(3), 275-289.
- Sprich, S., Biederman, J., Crawford, M. H., Mundy, E., & Faraone, S. V. (2000). Adoptive and biological families of children and adolescents with ADHD. *J Am Acad Child Adolesc Psychiatry, 39*(11), 1432-1437.
- Stergiakouli, E., Hamshere, M., Holmans, P., Langley, K., Zaharieva, I., Hawi, Z., et al. (2012). Investigating the contribution of common genetic variants to the risk and pathogenesis of ADHD. *Am J Psychiatry, 169*(2), 186-194.
- Stergiakouli, E., & Thapar, A. (2010). Fitting the pieces together: current research on the genetic basis of attention-deficit/hyperactivity disorder (ADHD). *Neuropsychiatr Dis Treat, 6*, 551-560.
- Stevenson, J. (2001). Comorbidity of reading/ spelling disability and ADHD. Attention, Genes and ADHD. *Brunner-Routledge*.
- Stevenson, J., Langley, K., Pay, H., Payton, A., Worthington, J., Ollier, W., et al. (2005). Attention deficit hyperactivity disorder with reading disabilities: preliminary genetic findings on the involvement of the ADRA2A gene. *J Child Psychol Psychiatry, 46*(10), 1081-1088.
- Stevenson, J., Pennington, B. F., Gilger, J. W., DeFries, J. C., & Gillis, J. J. (1993). Hyperactivity and spelling disability: testing for shared genetic aetiology. *J Child Psychol Psychiatry, 34*(7), 1137-1152.
- Strehl, U., Leins, U., Goth, G., Klinger, C., Hinterberger, T., & Birbaumer, N. (2006). Self-regulation of slow cortical potentials: a new treatment for children with attention-deficit/hyperactivity disorder. *Pediatrics, 118*(5), e1530-1540.

- Sumner, C. R., Gathercole, S., Greenbaum, M., Rubin, R., Williams, D., Hollandbeck, M., et al. (2009). Atomoxetine for the treatment of attention-deficit/hyperactivity disorder (ADHD) in children with ADHD and dyslexia. *Child Adolesc Psychiatry Ment Health, 3*, 40.
- Surman, C. B., Hammerness, P. G., Pion, K., & Faraone, S. V. (2013). Do stimulants improve functioning in adults with ADHD?: A review of the literature. *Eur Neuropsychopharmacol, 23*(6), 528-533.
- Suter, M., Abramovici, A., & Aagaard-Tillery, K. (2010). Genetic and epigenetic influences associated with intrauterine growth restriction due to in utero tobacco exposure. *Pediatr Endocrinol Rev, 8*(2), 94-102.
- Suter, M., Ma, J., Harris, A., Patterson, L., Brown, K. A., Shope, C., et al. (2011). Maternal tobacco use modestly alters correlated epigenome-wide placental DNA methylation and gene expression. *Epigenetics, 6*(11), 1284-1294.
- Swanson, H. L., Xinhua, Z., & Jerman, O. (2009). Working memory, short-term memory, and reading disabilities: a selective meta-analysis of the literature. *J Learn Disabil, 42*(3), 260-287.
- Swanson, J., Baler, R. D., & Volkow, N. D. (2011). Understanding the effects of stimulant medications on cognition in individuals with attention-deficit hyperactivity disorder: a decade of progress. *Neuropsychopharmacology, 36*(1), 207-226.
- Szuroimi, B., Czobor, P., Komlosi, S., & Bitter, I. (2011). P300 deficits in adults with attention deficit hyperactivity disorder: a meta-analysis. *Psychol Med, 41*(7), 1529-1538.
- Tannock, R., Martinussen, R., & Frijters, J. (2000). Naming speed performance and stimulant effects indicate effortful, semantic processing deficits in attention-deficit/hyperactivity disorder. *J Abnorm Child Psychol, 28*(3), 237-252.
- Taylor, E. (2011). Commentary: Reading and attention problems - how are they connected? Reflections on reading McGrath et al. (2011). *J Child Psychol Psychiatry, 52*(5), 558-559.
- Taylor, E., Chadwick, O., Heptinstall, E., & Danckaerts, M. (1996). Hyperactivity and conduct problems as risk factors for adolescent development. *J Am Acad Child Adolesc Psychiatry, 35*(9), 1213-1226.
- Taylor, E., Everitt, B., Thorley, G., Schachar, R., Rutter, M., & Wieselberg, M. (1986a). Conduct disorder and hyperactivity: II. A cluster analytic approach to the identification of a behavioural syndrome. *Br J Psychiatry, 149*, 768-777.

- Taylor, E., Sandberg, S., Thorley, G., & Giles, S. (1991). *The epidemiology of childhood hyperactivity* (Vol. 158). New York, NY: Oxford University Press.
- Taylor, E., Schachar, R., Thorley, G., Wieselberg, H. M., Everitt, B., & Rutter, M. (1987). Which boys respond to stimulant medication? A controlled trial of methylphenidate in boys with disruptive behaviour. *Psychol Med*, *17*(1), 121-143.
- Taylor, E., Schachar, R., Thorley, G., & Wieselberg, M. (1986b). Conduct disorder and hyperactivity: I. Separation of hyperactivity and antisocial conduct in British child psychiatric patients. *Br J Psychiatry*, *149*, 760-767.
- Teicher, M. H., Ito, Y., Glod, C. A., & Barber, N. I. (1996). Objective measurement of hyperactivity and attentional problems in ADHD. *J Am Acad Child Adolesc Psychiatry*, *35*(3), 334-342.
- Thapar, A., Cooper, M., Eyre, O., & Langley, K. (2013). What have we learnt about the causes of ADHD? *J Child Psychol Psychiatry*, *54*(1), 3-16.
- Thapar, A., Cooper, M., Jefferies, R., & Stergiakouli, E. (2012). What causes attention deficit hyperactivity disorder? *Arch Dis Child*, *97*(3), 260-265.
- Thapar, A., Harrington, R., Ross, K., & McGuffin, P. (2000). Does the definition of ADHD affect heritability? *J Am Acad Child Adolesc Psychiatry*, *39*(12), 1528-1536.
- Thapar, A., Holmes, J., Poulton, K., & Harrington, R. (1999). Genetic basis of attention deficit and hyperactivity. *Br J Psychiatry*, *174*, 105-111.
- Thapar, A., Langley, K., Asherson, P., & Gill, M. (2007). Gene-environment interplay in attention-deficit hyperactivity disorder and the importance of a developmental perspective. *Br J Psychiatry*, *190*, 1-3.
- Tiffin-Richards, M. C., Hasselhorn, M., Woerner, W., Rothenberger, A., & Banaschewski, T. (2008). Phonological short-term memory and central executive processing in attention-deficit/hyperactivity disorder with/without dyslexia--evidence of cognitive overlap. *J Neural Transm*, *115*(2), 227-234.
- Tiu, R. D., Jr., Thompson, L. A., & Lewis, B. A. (2003). The role of IQ in a component model of reading. *J Learn Disabil*, *36*(5), 424-436.
- Tomalski, P., & Johnson, M. H. (2010). The effects of early adversity on the adult and developing brain. *Curr Opin Psychiatry*, *23*(3), 233-238.
- Torgesen, J. K., Wagner, R. K., & Rashotte, C. A. (1999). Test of Word Reading Efficiency (TOWRE). Austin, TX: Pro-ed.
- Tripp, G., & Alsop, B. (2001). Sensitivity to reward delay in children with attention deficit hyperactivity disorder (ADHD). *J Child Psychol Psychiatry*, *42*(5), 691-698.

- Trouton, A., Spinath, F. M., & Plomin, R. (2002). Twins early development study (TEDS): a multivariate, longitudinal genetic investigation of language, cognition and behavior problems in childhood. *Twin Res*, 5(5), 444-448.
- Trzesniewski, K. H., Moffitt, T. E., Caspi, A., Taylor, A., & Maughan, B. (2006). Revisiting the association between reading achievement and antisocial behavior: new evidence of an environmental explanation from a twin study. *Child Dev*, 77(1), 72-88.
- Tye, C., McLoughlin, G., Kuntsi, J., & Asherson, P. (2011). Electrophysiological markers of genetic risk for attention deficit hyperactivity disorder. *Expert Rev Mol Med*, 13, e9.
- Tye, C., Rijdsdijk, F., Greven, C. U., Kuntsi, J., Asherson, P., & McLoughlin, G. (2012). Shared genetic influences on ADHD symptoms and very low-frequency EEG activity: a twin study. *J Child Psychol Psychiatry*, 53(6), 706-715.
- Uebel, H., Albrecht, B., Asherson, P., Borger, N. A., Butler, L., Chen, W., et al. (2010). Performance variability, impulsivity errors and the impact of incentives as gender-independent endophenotypes for ADHD. *J Child Psychol Psychiatry*, 51(2), 210-218.
- Valko, L., Doehnert, M., Muller, U. C., Schneider, G., Albrecht, B., Dreschler, R., et al. (2009). Differences in neurophysiological markers of inhibitory and temporal processing deficits in children and adults with ADHD. *Journal of Psychophysiology*, 23, 235-246.
- van Beijsterveldt, C. E., Verhulst, F. C., Molenaar, P. C., & Boomsma, D. I. (2004). The genetic basis of problem behavior in 5-year-old dutch twin pairs. *Behav Genet*, 34(3), 229-242.
- van de Meer, N. (2002). The role of attention. *Hyperactivity and Attention Disorders of Childhood* (ed. S. Sandberg), pp. 162-213. Cambridge University Press: Cambridge.
- Van der Meere, J. J. (2002). *The role of attention*. In S. Sanberg (Ed.), *Hyperactivity Disorders of Childhood* (2nd ed., pp.162-298). Cambridge: Cambridge University press.
- Van der Oord, S., Prins, P. J., Oosterlaan, J., & Emmelkamp, P. M. (2008). Efficacy of methylphenidate, psychosocial treatments and their combination in school-aged children with ADHD: a meta-analysis. *Clin Psychol Rev*, 28(5), 783-800.
- van Leeuwen, M., van den Berg, S. M., Peper, J. S., Hulshoff Pol, H. E., & Boomsma, D. I. (2009). Genetic covariance structure of reading, intelligence and memory in children. *Behav Genet*, 39(3), 245-254.

- van Leeuwen, T. H., Steinhausen, H. C., Overtoom, C. C., Pascual-Marqui, R. D., van't Klooster, B., Rothenberger, A., et al. (1998). The continuous performance test revisited with neuroelectric mapping: impaired orienting in children with attention deficits. *Behav Brain Res, 94*(1), 97-110.
- van Lieshout, M., Luman, M., Buitelaar, J., Rommelse, N. N., & Oosterlaan, J. (2013). Does neurocognitive functioning predict future or persistence of ADHD? A systematic review. *Clin Psychol Rev, 33*(4), 539-560.
- Vanhatalo, S., Palva, J. M., Holmes, M. D., Miller, J. W., Voipio, J., & Kaila, K. (2004). Infraslow oscillations modulate excitability and interictal epileptic activity in the human cortex during sleep. *Proc Natl Acad Sci U S A, 101*(14), 5053-5057.
- Wadsworth, S. J., DeFries, J. C., Olson, R. K., & Willcutt, E. G. (2007). Colorado longitudinal twin study of reading disability. *Ann Dyslexia, 57*(2), 139-160.
- Wadsworth, S. J., Olson, R. K., & Defries, J. C. (2000). Differential Genetic Etiology of Reading Difficulties as a Function of IQ: An Update. *Behav Genet.*
- Wahlstedt, C., Thorell, L. B., & Bohlin, G. (2008). ADHD symptoms and executive function impairment: early predictors of later behavioral problems. *Dev Neuropsychol, 33*(2), 160-178.
- Wechsler, D. (1991). Wechsler Intelligence Scale for Children (3rd ed.) London: The Psychological Corporation.
- Wechsler, D. (1997a). *Wechsler Adult Intelligence Scale (3rd ed.)*. The Psychological Corporation. San Antonio, TX.
- Wechsler, D. (1997b). Wechsler Adult Intelligence Scale (3rd ed.) London: The Psychological Corporation.
- Wechsler, D. (1999). *Wechsler Abbreviated Scale of Intelligence (WASI)*. Harcourt Assessment. San Antonio, TX.
- Wiersema, R., van der Meere, J., Antrop, I., & Roeyers, H. (2006a). State regulation in adult ADHD: an event-related potential study. *J Clin Exp Neuropsychol, 28*(7), 1113-1126.
- Wiersema, R., van der Meere, J., Roeyers, H., Van Coster, R., & Baeyens, D. (2006b). Event rate and event-related potentials in ADHD. *J Child Psychol Psychiatry, 47*(6), 560-567.
- Willcutt, E. G. (2012). The prevalence of DSM-IV attention-deficit/hyperactivity disorder: a meta-analytic review. *Neurotherapeutics, 9*(3), 490-499.

- Willcutt, E. G., Betjemann, R. S., McGrath, L. M., Chhabildas, N. A., Olson, R. K., DeFries, J. C., et al. (2010). Etiology and neuropsychology of comorbidity between RD and ADHD: the case for multiple-deficit models. *Cortex*, *46*(10), 1345-1361.
- Willcutt, E. G., Boada, R., Riddle, M., Chhabildas, N., DeFries, J. C., & Pennington, B. (2011a). Colorado Learning Difficulties Questionnaire: Validation of a parent-report screening measure. (*Under review*).
- Willcutt, E. G., Boada, R., Riddle, M. W., Chhabildas, N., DeFries, J. C., & Pennington, B. F. (2011b). Colorado Learning Difficulties Questionnaire: validation of a parent-report screening measure. *Psychol Assess*, *23*(3), 778-791.
- Willcutt, E. G., Doyle, A. E., Nigg, J. T., Faraone, S. V., & Pennington, B. F. (2005a). Validity of the executive function theory of attention-deficit/hyperactivity disorder: a meta-analytic review. *Biol Psychiatry*, *57*(11), 1336-1346.
- Willcutt, E. G., Nigg, J. T., Pennington, B. F., Solanto, M. V., Rohde, L. A., Tannock, R., et al. (2012). Validity of DSM-IV attention deficit/hyperactivity disorder symptom dimensions and subtypes. *J Abnorm Psychol*, *121*(4), 991-1010.
- Willcutt, E. G., & Pennington, B. F. (2000). Psychiatric comorbidity in children and adolescents with reading disability. *J Child Psychol Psychiatry*, *41*(8), 1039-1048.
- Willcutt, E. G., Pennington, B. F., Boada, R., Ogline, J. S., Tunick, R. A., Chhabildas, N. A., et al. (2001). A comparison of the cognitive deficits in reading disability and attention-deficit/hyperactivity disorder. *J Abnorm Psychol*, *110*(1), 157-172.
- Willcutt, E. G., Pennington, B. F., & DeFries, J. C. (2000a). Etiology of inattention and hyperactivity/impulsivity in a community sample of twins with learning difficulties. *J Abnorm Child Psychol*, *28*(2), 149-159.
- Willcutt, E. G., Pennington, B. F., & DeFries, J. C. (2000b). Twin study of the etiology of comorbidity between reading disability and attention-deficit/hyperactivity disorder. *Am J Med Genet*, *96*(3), 293-301.
- Willcutt, E. G., Pennington, B. F., Olson, R. K., Chhabildas, N., & Hulslander, J. (2005b). Neuropsychological analyses of comorbidity between reading disability and attention deficit hyperactivity disorder: in search of the common deficit. *Dev Neuropsychol*, *27*(1), 35-78.
- Willcutt, E. G., Pennington, B. F., Olson, R. K., & DeFries, J. C. (2007). Understanding comorbidity: a twin study of reading disability and attention-deficit/hyperactivity disorder. *Am J Med Genet B Neuropsychiatr Genet*, *144B*(6), 709-714.

- Willcutt, E. G., Sonuga-Barke, E., Nigg, J. T., & Sergeant, J. (2008a). Recent developments in neuropsychological models of childhood disorders. *Advances in Biological Psychiatry, 24*, 195-226.
- Willcutt, E. G., Sonuga-Barke, E., Nigg, J. T., & Sergeant, J. A. (2008b). Recent developments in neuropsychological models of childhood disorders. *Advances in Biological Psychiatry, 24*, 195-226.
- Williams, L. M., Simms, E., Clark, C. R., Paul, R. H., Rowe, D., & Gordon, E. (2005). The test-retest reliability of a standardized neurocognitive and neurophysiological test battery: 'neuromarker'. *Int J Neurosci, 115*(12), 1605-1630.
- Williams, N. M., Franke, B., Mick, E., Anney, R. J., Freitag, C. M., Gill, M., et al. (2012). Genome-wide analysis of copy number variants in attention deficit hyperactivity disorder: the role of rare variants and duplications at 15q13.3. *Am J Psychiatry, 169*(2), 195-204.
- Wolraich, M. L., Lambert, E. W., Bickman, L., Simmons, T., Doffing, M. A., & Worley, K. A. (2004). Assessing the impact of parent and teacher agreement on diagnosing attention-deficit hyperactivity disorder. *J Dev Behav Pediatr, 25*(1), 41-47.
- Wood, A. C., Asherson, P., Rijdsdijk, F., & Kuntsi, J. (2009a). Is overactivity a core feature in ADHD? Familial and receiver operating characteristic curve analysis of mechanically assessed activity level. *J Am Acad Child Adolesc Psychiatry, 48*(10), 1023-1030.
- Wood, A. C., Asherson, P., Rijdsdijk, F., & Kuntsi, J. (2009b). Is overactivity a core feature in ADHD? Familial and receiver operating characteristic curve analysis of mechanically assessed activity level. *J Am Acad Child Adolesc Psychiatry, 48*(10), 1023-1030.
- Wood, A. C., Asherson, P., van der Meere, J. J., & Kuntsi, J. (2009c). Separation of genetic influences on attention deficit hyperactivity disorder symptoms and reaction time performance from those on IQ. *Psychol Med, 1*-11.
- Wood, A. C., Asherson, P., van der Meere, J. J., & Kuntsi, J. (2010a). Separation of genetic influences on attention deficit hyperactivity disorder symptoms and reaction time performance from those on IQ. *Psychol Med, 40*(6), 1027-1037.
- Wood, A. C., & Neale, M. C. (2010). Twin studies and their implications for molecular genetic studies: endophenotypes integrate quantitative and molecular genetics in ADHD research. *J Am Acad Child Adolesc Psychiatry, 49*(9), 874-883.

- Wood, A. C., Rijdsdijk, F., Johnson, K. A., Andreou, P., Albrecht, B., Arias-Vasquez, A., et al. (2010b). The relationship between ADHD and key cognitive phenotypes is not mediated by shared familial effects with IQ. *Psychol Med*, 1-11.
- Wood, A. C., Rijdsdijk, F., Johnson, K. A., Andreou, P., Albrecht, B., Arias-Vasquez, A., et al. (2011). The relationship between ADHD and key cognitive phenotypes is not mediated by shared familial effects with IQ. *Psychol Med*, 41(4), 861-871.
- Wood, A. C., Rijdsdijk, F., Saudino, K. J., Asherson, P., & Kuntsi, J. (2008). High heritability for a composite index of children's activity level measures. *Behav Genet*, 38(3), 266-276.
- Wood, A. C., Saudino, K. J., Rogers, H., Asherson, P., & Kuntsi, J. (2007). Genetic influences on mechanically-assessed activity level in children. *J Child Psychol Psychiatry*, 48(7), 695-702.
- World Health Organisation. (2005). *International Classification of Diseases and Health Related Problems, Tenth Revision (ICD-10) (2nd ed.)*. Geneva.
- Zillessen, K. E., Scheuerpflug, P., Fallgatter, A. J., Strik, W. K., & Warnke, A. (2001). Changes of the brain electrical fields during the continuous performance test in attention-deficit hyperactivity disorder-boys depending on methylphenidate medication. *Clin Neurophysiol*, 112(7), 1166-1173.
- Zwirs, B. W., Burger, H., Schulpen, T. W., Wiznitzer, M., Fedder, H., & Buitelaar, J. K. (2007). Prevalence of psychiatric disorders among children of different ethnic origin. *J Abnorm Child Psychol*, 35(4), 556-566.

Appendices

Appendix A. Univariate genetic analyses results of inattention, reading difficulties, reaction time variability, digit span forward and backward

Univariate models	-2LL	df	χ^2	df	p	$\Delta\chi^2$	Δdf	p	AIC
Inattention									
Saturated model	5835.21	1141							
ACE	5882.74	1144	47.53	3	<0.01				41.53
ADE	5864.96	1144	29.75	3	<0.01				23.75
DE	5864.96	1145	29.75	4	<0.01	0.00	1	>0.9	-2.00
AE	5882.74	1145	47.53	4	<0.01	17.78	1	<0.001	15.78
E	5949.90	1146	114.69	5	<0.01	84.94	2	<0.001	80.94
Reading difficulties									
Saturated model	6619.06	1289							
ACE	6642.71	1292	23.65	3	<0.001				17.65
ADE	6632.84	1292	13.78	3	<0.01				7.78
DE	6632.85	1293	13.77	4	<0.01	0.01	1	>0.9	-1.99
AE	6642.71	1293	23.65	4	<0.001	9.87	1	<0.01	7.87
E	6795.09	1294	176.03	5	<0.001	162.25	2	<0.001	158.25

Reaction time variability

Saturated model	6321.61	1228							
ACE	6325.39	1231	3.78	3	0.29				-2.22
CE	6333.68	1232	12.07	4	0.02	8.29	1	<0.01	6.29
AE	6325.39	1232	3.78	4	0.94	0.00	1	>0.9	-1.99
E	6389.89	1233	68.28	5	<0.01	64.50	2	<0.001	60.50

Digit span forward

Saturated model	6627.33	1290							
ACE	6631.35	1293	4.02	3	0.26				-1.98
CE	6660.80	1294	33.47	4	<0.001	29.45	1	<0.001	27.45
AE	6631.35	1294	4.02	4	0.40	0	1	>0.9	-2.00
E	6771.18	1295	143.85	5	<0.001	139.82	2	<0.001	135.82

Digit span backward

Saturated model	6613.74	1290							
ACE	6617.21	1293	3.47	3	0.32				-2.53
CE	6621.80	1294	8.06	4	0.09	4.59	1	0.03	2.59
AE	6617.21	1294	3.47	4	0.48	0	1	>0.90	-2.00
E	6644.87	1295	31.13	5	<0.01	27.67	2	<0.001	23.66

Appendix B. Within trait cross-twin correlations for inattention (IA), reaction time variability (RTV), reading difficulties questionnaire (RDQ), digit span forward (DSF) and digit span backward (DSB) between male monozygotic twins (MZM), female monozygotic twins (MZF), male dizygotic twins (DZM), female dizygotic twins (DZF) and opposite-sex dizygotic twins (DZOS)

	MZM	MZF	DZM	DZF	DZOS
IA	0.55	0.61	0.01	0.00	0.13
RDQ	0.73	0.81	0.24	-0.04	0.18
RTV	0.37	0.56	0.19	0.27	0.18
DSF	0.65	0.60	0.34	0.47	0.22
DSB	0.25	0.41	0.10	0.24	0.09

Appendix C. Cognitive profiles of a) IQ, b) reaction time variability (RTV), c) commission errors (CE) and d) omission errors (OE) in full remitters, individuals who meet criteria for ADHD symptoms only (Symptoms only) or individuals who meet criteria for functional impairment only (Impairments only), ADHD persisters and controls

a)

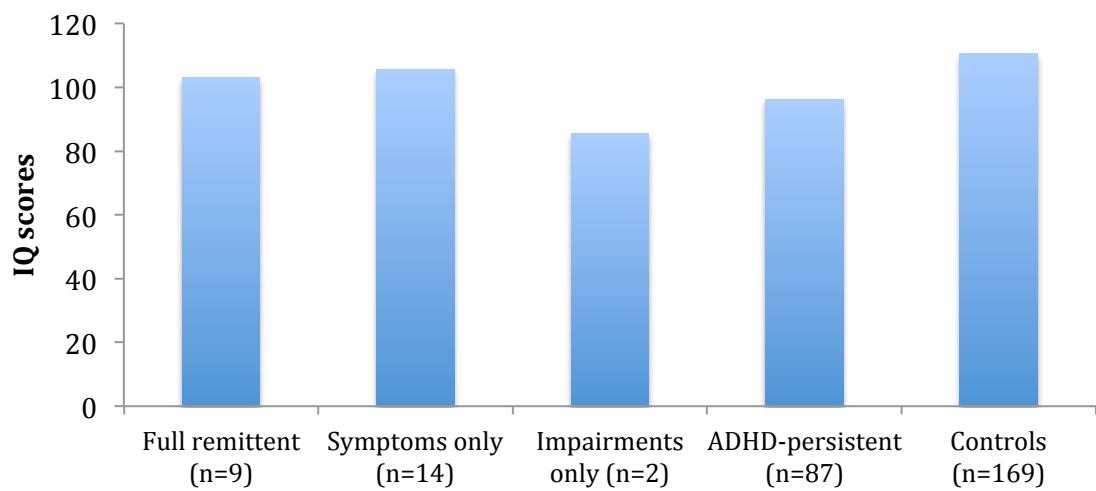

b)

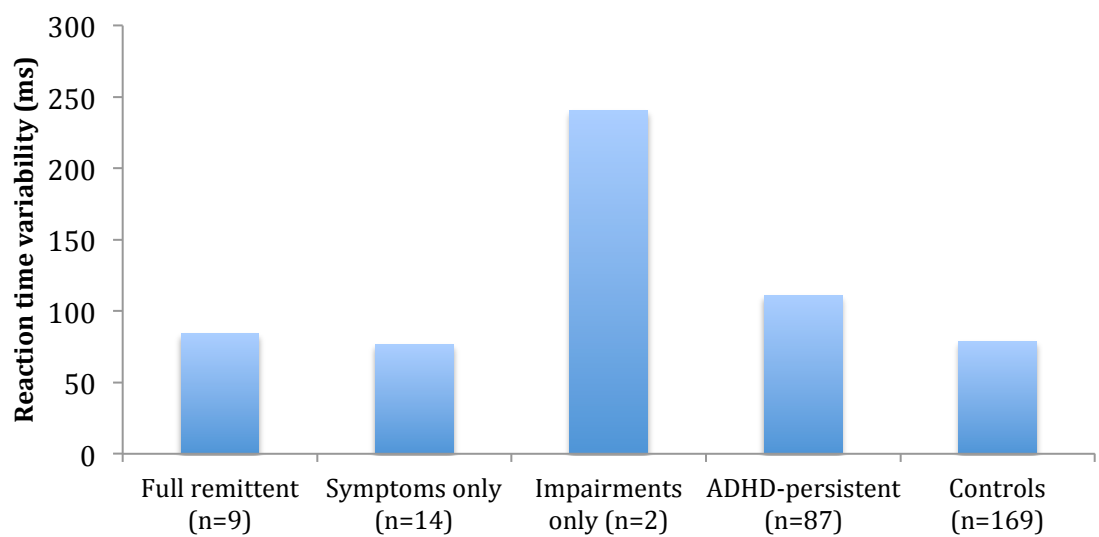

c)

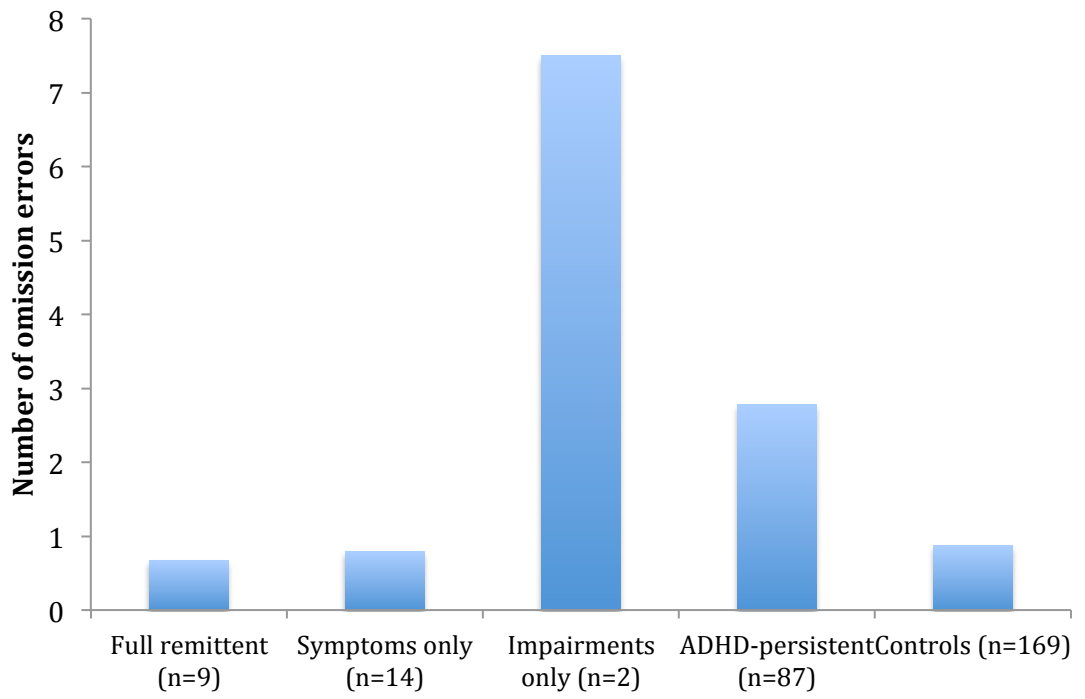

d)

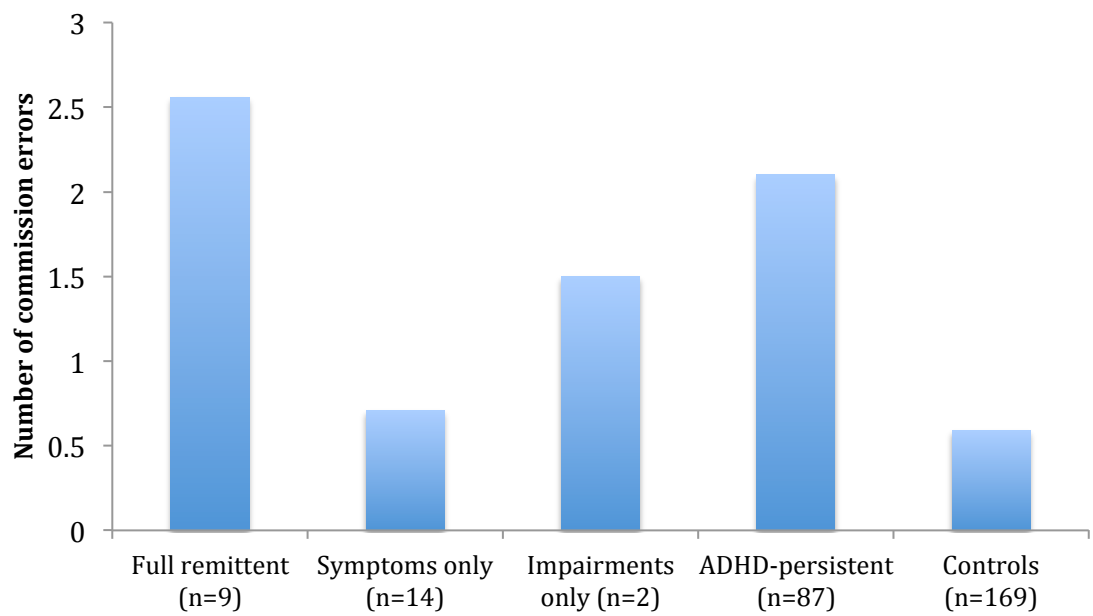

Appendix D. Delta power (0.5-3.5Hz) during (a) the Continuous Performance Task and (b) the Fast Task (baseline condition) in frontal region in ADHD persisters (red), ADHD remitters (green) and controls (blue)

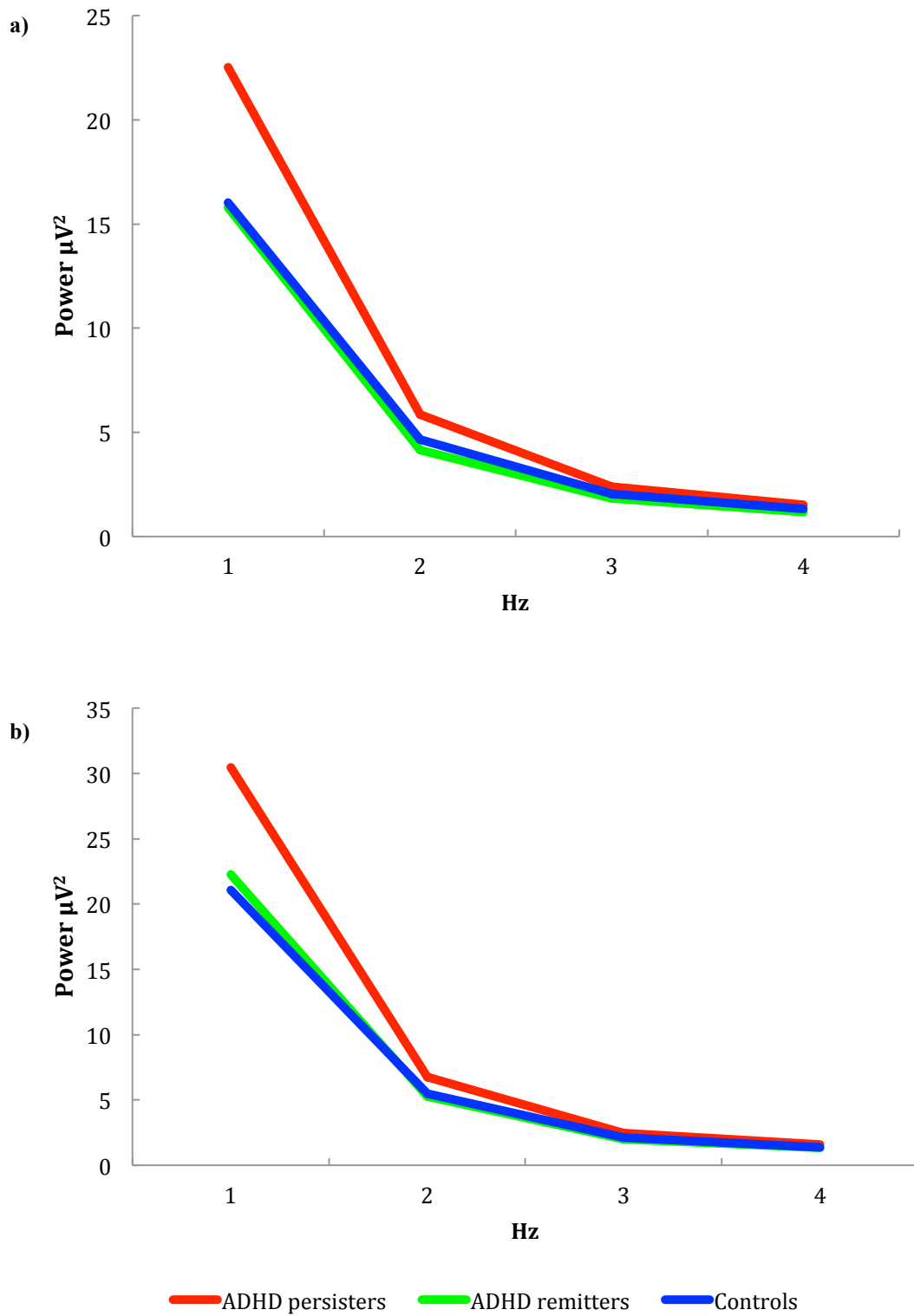

Appendix E. Theta (4-7 Hz) and alpha power (7-12Hz) during (a) the Continuous Performance Task and (b) the Fast Task (baseline condition) in frontal region in ADHD persisters (red), ADHD remitters (green) and controls (blue)

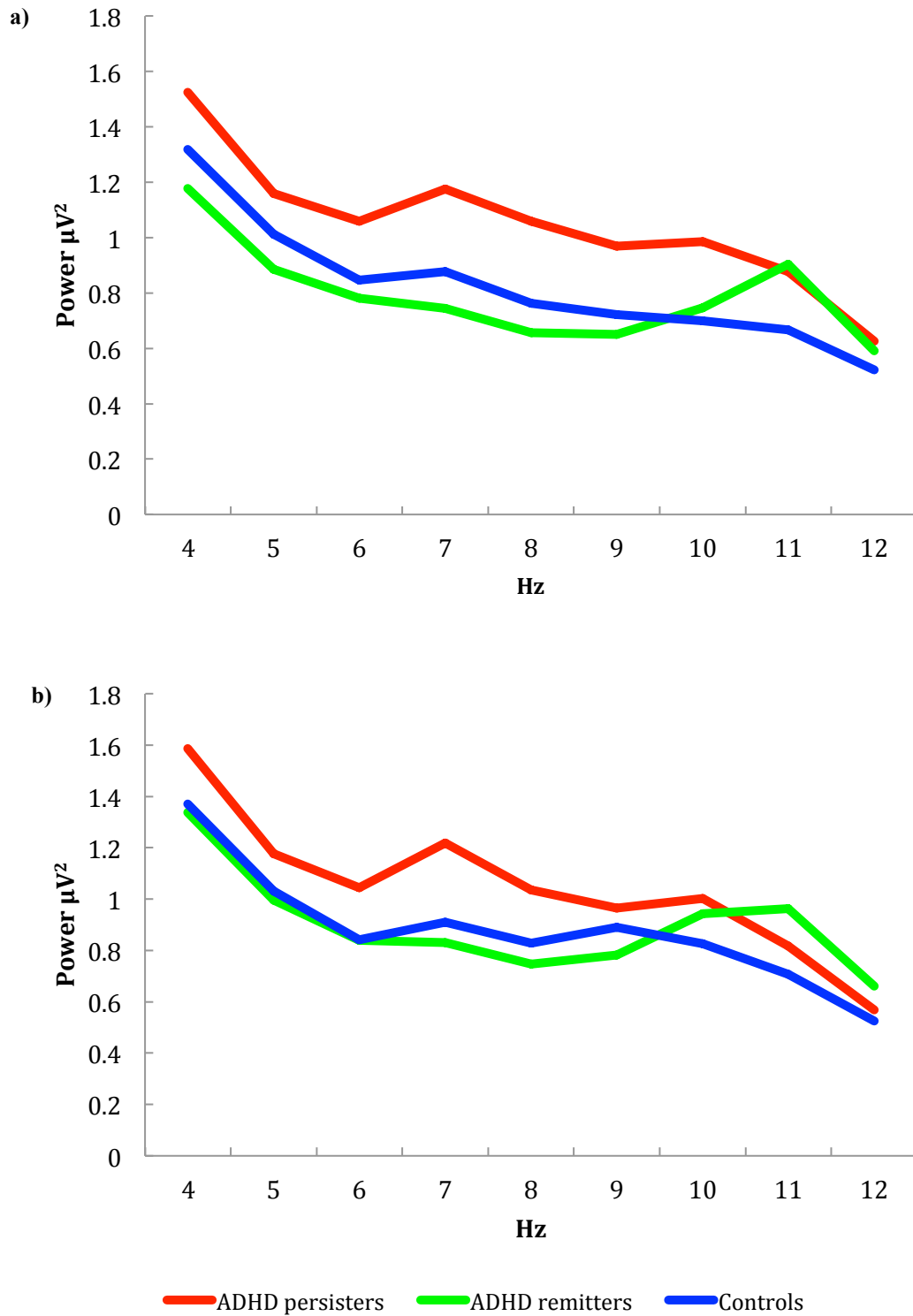

Appendix F. Beta power (12-30 Hz) during (a) the Continuous Performance Task and (b) the Fast Task (baseline condition) in frontal region in ADHD persisters (red), ADHD remitters (green) and controls (blue)

