



King's Research Portal

DOI:

[10.1109/MCOM.2016.7565257](https://doi.org/10.1109/MCOM.2016.7565257)

Document Version

Peer reviewed version

[Link to publication record in King's Research Portal](#)

Citation for published version (APA):

Holland, O. D., Aijaz, A., Kaltenberger, F., Foukalas, F., Vivier, G., Buczkowski, M., & Pietrzyk, S. (2016). Management Architecture for Aggregation of Heterogeneous Systems and Spectrum Bands. *IEEE COMMUNICATIONS MAGAZINE*, 54(9). <https://doi.org/10.1109/MCOM.2016.7565257>

Citing this paper

Please note that where the full-text provided on King's Research Portal is the Author Accepted Manuscript or Post-Print version this may differ from the final Published version. If citing, it is advised that you check and use the publisher's definitive version for pagination, volume/issue, and date of publication details. And where the final published version is provided on the Research Portal, if citing you are again advised to check the publisher's website for any subsequent corrections.

General rights

Copyright and moral rights for the publications made accessible in the Research Portal are retained by the authors and/or other copyright owners and it is a condition of accessing publications that users recognize and abide by the legal requirements associated with these rights.

- Users may download and print one copy of any publication from the Research Portal for the purpose of private study or research.
- You may not further distribute the material or use it for any profit-making activity or commercial gain
- You may freely distribute the URL identifying the publication in the Research Portal

Take down policy

If you believe that this document breaches copyright please contact librarypure@kcl.ac.uk providing details, and we will remove access to the work immediately and investigate your claim.

Management Architecture for Aggregation of Heterogeneous Systems and Spectrum Bands

Oliver Holland and Adnan Aijaz, King's College London, UK

Florian Kaltenberger, Eurecom, France

Fotis Foukalas, Athena Research and Innovation Centre, Greece

Guillaume Vivier, Sequans Communications, France

Mateusz Buczkowski and Slawomir Pietrzyk, IS-Wireless, Poland

Abstract

Mobile networks will increasingly need to make use of heterogeneous access and spectrum opportunities to realize required capacity and quality of service. Moreover, aggregation of such resources will routinely be necessary, and there will be a clear need to develop a management architecture for that aggregation. Such an architecture should ascertain what can and should be aggregated by particular systems, networks and terminals in view of better managing the collection of available resources on a heterogeneous system level, taking into account all systems', networks' and terminals' traffic requirements and technical capabilities. This article proposes such a management architecture and assesses its benefits quantified by some particular examples.

1 Introduction

In recent years, mobile communications operators and systems have been presented with significant increases in quality spectrum available to them through the assignment of a range of additional frequency bands, as well as developments that will eventually see them extensively using different types of spectrum in addition to conventional licensed spectrum [1]. While this bandwidth increase has been a key factor in the realization of promising new mobile communications standards and technologies leading to profound increases in achieved link and system capacity, the eternal march of Cooper's law and similar such projections will mean that further capacity and associated spectrum increase will be necessary for future communications systems realizing 5G [2]. Additionally, assumptions in 5G, such as the ability to provide link latencies of the order of 1 ms, access for massive amount of connected terminals, and ultra-high reliability [3], also indirectly lead to big increases in spectrum demand.

In extracting the maximum available spectrum in order to realize such demands, it is noted that the range of bands utilized by mobile communications systems is becoming increasingly fragmented, discontinuously covering a vast array of different frequencies with very different characteristics. This trend is expected to accelerate in coming years, with the expectation that 5G will occupy many frequency bands ranging from extremely low frequencies (e.g., UHF, under 1 GHz) to extremely high

frequencies (mm-wave, up to 60 GHz or more) being a good illustration of that. Moreover, this fragmentation of spectrum and associated characteristics will be emphasized by the supplemental use of different types of spectrum such as unlicensed spectrum, already coming to fruition in the form of LTE-Unlicensed (LTE-U) and Licensed Assisted Access (LAA) [1].

In the light of this, future mobile communications systems leading to 5G must be able to concurrently make use of the range of spectrum and link opportunities at a particular location, such that they are not constrained to only one of the many spectrum possibilities, thereby limiting capacity and other Quality of Service (QoS) characteristics. This will often be the case even for individual wireless links needing to aggregate a range of resources in order to realize the required capacity of those links. Attribution of appropriate spectrum and/or link opportunities among cells/terminals based on each of their associated traffic demands is a complex problem, comprising many different possible dimensions in the parameterization state space with a plethora of possible outcomes. This complexity is increased significantly when aggregation of discontinuous resource sets and link opportunities is introduced into the equation, causing the introduction of further degrees of freedom and a range of differing types of constraints. Given such complexity, it is important to underline the need to carefully manage which terminals/cells should aggregate which resources, based on their traffic/QoS demands and capabilities, their current context (e.g., mobility), among other factors. Further, in order to achieve such aggregation, it is necessary for such a management solution to be standardized among the operators/networks and terminals that are using it, as well as with other operators/networks given that ultimately different instantiations of such systems will all need to talk with each other to avoid interference on the radio level.

With the above issues in mind, in this article we propose and assess the broad characteristics of such a management architecture. Section 2 introduces the elements of the architecture, their functionalities and the types of information handled. Section 3 discusses the use cases for the management architecture, particularly emphasizing the links with the characteristics presented in Section 2. Section 4 presents some example results from aggregation, as would be assisted by the use of such an architecture. Section 5 concludes.

2 SOLDER Aggregation Management Architecture

Our proposed management architecture to serve aggregation scenarios is illustrated in this section. The architecture and capabilities are inspired by the IEEE 1900.4 standard [4], the distinction of this paper being that architectural elements and functional capabilities are tailored for the context of matching of traffic demand to aggregation opportunities, as well as link and spectrum availability and capability in general.

The underlying approach is to design a management system that decides on a set of actions required to optimize spectrum usage in view of spectrum aggregation, based on localized context information. This framework, however, can also apply directly to allocation of terminals to available link opportunities, or to effectively assigning radios to spectrum through other such predefined intermediate layers that define or otherwise frame the usage of that spectrum. The architecture assumes a distributed approach to spectrum aggregation whereby the terminals assist the network in optimizing the aggregation decision. The terminals feed information on their traffic requirements to the network, based on which the network side makes aggregation decisions in order to satisfy demand

while also taking into account the terminals' and networks' (RANs) aggregation capabilities, as well as the traffic demands of other terminals.

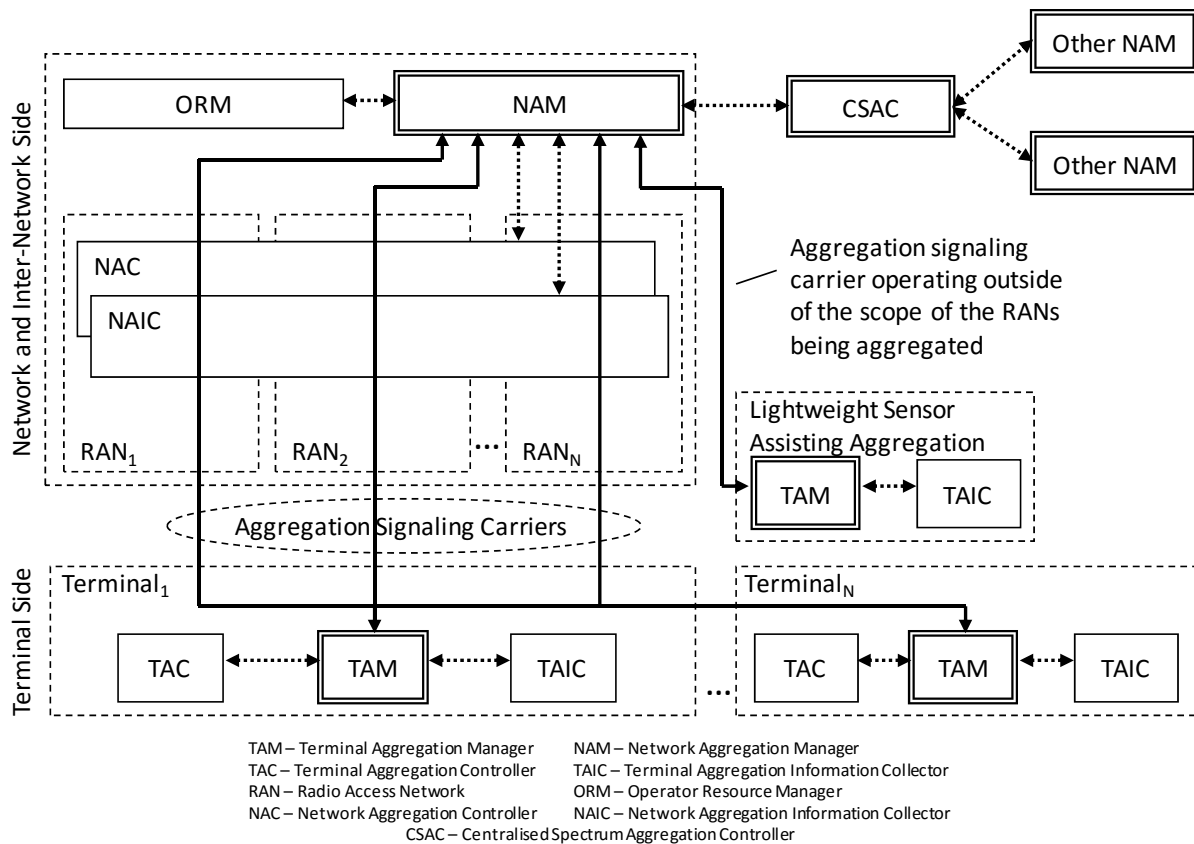

Figure 1: The aggregation-supporting architecture.

The proposed architecture is shown in Figure 1. This architecture enables the management of aggregation among the range of Radio Access Technologies (RATs) that have access to a range of different spectrum opportunities. It encompasses the necessary functionality to manage and implement aggregation decisions both on the network side and the terminal side, to convey decisions and constraints from the network side to the terminal side, and to obtain context information that is necessary to make aggregation decisions from the terminal side and RANs. The different entities are introduced as follows:

- *Centralized Spectrum Aggregation Controller (CSAC)*: This entity has global visibility of spectrum usage of different networks. It plays the pivotal role in spectrum aggregation decisions in the context of heterogeneous RAT scenarios where multiple NAMs might exist in the scope of different owners or decision makers.
- *Network Aggregation Manager (NAM)*: This entity obtains information from the range of RATs, carriers and spectrum opportunities that are available, as well as (indirectly, from the TAM) information from the terminal side on the aggregation opportunities locally available there, the traffic demands of the user, and other information such as the current interference situation in spectrum that might be aggregated. It uses this information to make decisions about which resources should be provided and aggregated among different terminals in order to satisfy the traffic demand to each of the terminals. It creates aggregation instructions or policies, and conveys them to the RANs and the TAM at which points they are im-

plemented. It is noted that multiple instances of the NAM might exist elsewhere in different networks or under different spheres of control. In such cases where multiple instances do exist and the NAMs are collaborating, collaborative decisions will be taken among the NAMs via the CSAC.

- *Terminal Aggregation Manager (TAM)*: This entity obtains aggregation instructions and policies from the NAM, and implements those aggregation instructions or policies. Importantly, the aggregation policies might leave some scope for this entity to make its own aggregation decisions on the terminal side, based on the local situation. The TAM instructs the TAC to implement the aggregation, and requests context information from the TAIC which is then forwarded to the NAM. The NAM might also specifically request context information to assist its aggregation decisions and formation of aggregation policies via the TAM/TAIC.
- *Operator Resource Manager (ORM)*: This is the entity responsible for conventional resource management decisions on the operator side, including decisions on resources that should be aggregated for a particular user. Of course, the NAM has to take into account the policies of this entity, and perhaps negotiate with this entity in making an aggregation decision.
- *Network Aggregation Controller (NAC)*: This entity obtains the aggregation instructions from the NAM, and implements them in/among RANs.
- *Network Aggregation Information Collector (NAIC)*: This entity obtains the context information requests from the NAM, and gathers context information and forwards it back to the NAM.
- *Terminal Aggregation Controller (TAC)*: This entity obtains the aggregation instructions from the NAM, via the TAM (incorporating also the possibility in some cases for the instructions to originate at the TAM), and implements the aggregation instructions on the terminal side.
- *Terminal Aggregation Information Collector (TAIC)*: This entity obtains the context information requests from the NAM, via the TAM (incorporating also the possibility in some cases for the context information requests to originate at the TAM), and gathers context information and forwards it back to the TAM (which then, when/as required, forwards this information to the NAM).
- *Radio Access Network (RAN)*: The RANs can be different RANs within the same network, or RANs in different networks operating the same RAT, or RANs in different networks operating different RATs.

The functionalities of the key network- and terminal-side entities, the NAM and TAM, are described in the example as follows.

2.1 Operational Example

The example we present here is for the case where the network receives context information from the terminal side, and makes decisions on which of the available RATs to aggregate for which terminals and if applicable the spectrum resources that can be used or aggregated by those RATs, in order to satisfy terminals' traffic demands.

In this context, the TAM (via the TAIC) obtains information on the availability of resources locally, and is aware of the traffic demands at the terminal. It forwards this information to the NAM. The NAM also needs to be aware of which resources are available and the sum traffic requirements on the network side in order to make appropriate aggregation decisions, obtaining this information via

the NAIC. The NAM then has a network or inter-network/system level overview on resource/traffic requirements for all terminals, and is able to decide on which resources should be aggregated for which terminals and networks. Its decisions also involve the operator's directives/policies, as obtained from the ORM, and may involve collaboration with other NAMs through the CSAC as a mediator. Once the decision on resources/RATs to aggregate for each terminal is made, the NAM instructs the NAC on the network side to implement the decision, and informs the TAM, which in turn instructs the TAC to implement the decisions on the terminal side. It is observed that these decisions could instead be replaced by policies/rules determining which resources should be aggregated for which terminals in which circumstances, potentially also leaving terminals and network elements some scope to locally manage their aggregation/resource decisions within the constraints of the conveyed policies.

3 Scenarios and Use Cases for the Management Architecture

This section illustrates how the management architecture can be applied to several use cases ranging from current LTE-A deployments to more futuristic ones such as based on 5G. It also discusses the application to more generalized cases.

3.1 Cellular 4G/5G Systems

First we show how the architecture can be applied to an LTE-Advanced (LTE-A) system that naturally supports carrier aggregation. Conventionally, LTE systems operate in licensed bands and therefore do not employ any opportunistic access; this necessitates such an architecture as we introduce in this paper.

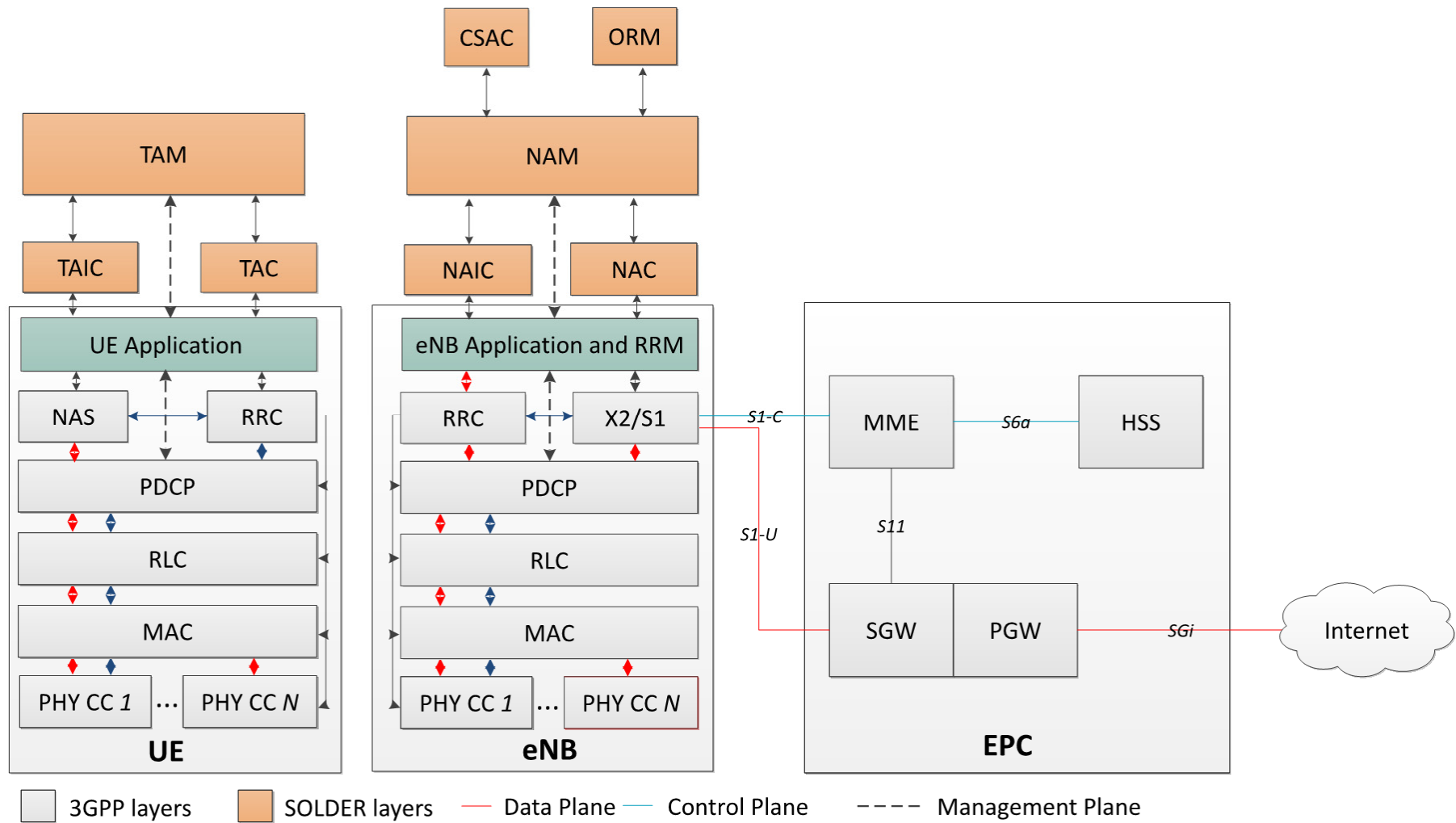

Figure 2: Example of system-level overlay management architecture for LTE-LTE aggregation.

Moreover, we can also envisage the use of LTE technology in unlicensed, license-exempt (such as TVWS), or license-shared bands; since 3GPP (LTE) Release 13, it has been possible to use LTE in the unlicensed 5 GHz U-NII band. This feature is also known as LTE unlicensed (LTE-U) or Licensed Assisted Access (LAA). Another scenario is use of LTE in licensed shared access (LSA), where at least two mobile operators share the same spectrum.

The extension of the LTE system architecture with elements from the SOLDER management architecture can greatly improve the overall system performance in such scenarios. Figure 2 shows an example of such a combined architecture, where we propose that the eNB application is extended with the NAC and NAIC entities, allowing it to communicate with a NAM. At the terminal side the UE application shall be extended with TAC and TAIC entities to allow it to communicate with a TAM.

In the case of pure LTE where such capabilities are already present, the extension of the UE architecture with TAM/TAC/TAIC entities is optional. If they were present, the TAM could establish communication with the NAM through a special radio bearer to assist the NAM in the decision making process (e.g., by providing measurements) or in implementing policies. If they were not present, the eNB application would be responsible for translating primitives to and from the NAM into LTE-specific primitives and use standard LTE RRC functionality for measurement reporting and radio resource configuration.

3.1.1 Coordinated Carrier Aggregation (CoCA) in Heterogeneous Networks

CA has been introduced in LTE-Advanced (Release 10 and later). The allocation of component carriers (CCs) is made in a semi-static manner using RRC signaling, while the activation / deactivation can be made dynamically using MAC level signaling. A Release 13 work item (WI) aims at increasing the maximum number of CCs up to 32, and it appears that these CCs may span over many spectrum bands including unlicensed ones [10]. Thus, a big challenge for HetNets will be to manage the CCs allocation and aggregation for particular users. This should be done in a coordinated fashion, which we term as Coordinated CA (CoCA).

Spectrum assignment deals with the CCs allocation mechanism that can be provided using several criteria of CCs selection, according to the objectives of the overall aggregated network capacity or throughput. The spectrum aggregation management functional architecture in Figure 2 should enable us to encapsulate such solutions. In particular, the following features should be added:

- Spectrum selection relying on different policies originating from the operators. Particular dispersed spectrum bands should be made available to the NAM/CSAC.
- Spectrum assignment evaluation accomplished at the terminal side, based on the channel state information (CSI) estimation for each CC.
- Spectrum aggregation decision and control, provided in a coordinated fashion using the feedback reports (e.g., CSI) from each user for each CC.

Details about the CoCA mechanism implementation, including obtained results, are given in the next section.

3.1.2 Licensed Assisted Access

LAA has been recently introduced within the 3GPP framework in order to provide the aggregation of licensed and unlicensed bands as the ultimate application of CR principles to beyond 4G communica-

tion networks. In order to avoid unfairness or interference to legacy Wi-Fi users, LTE needs to be adapted to include the following capabilities [9]:

- Listen Before Talk (LBT), requiring the application of a clear channel assessment (CCA) check before using the channel.
- Discontinuous transmission (DTX) on a carrier with limited maximum transmission duration.
- Carrier selection (CS), so that LTE-U nodes can use carriers with low interference.
- Transmission Power Control (TPC), a regulatory requirement in some regions by which the transmitting terminal should be able to reduce the transmit power in some proportion to the maximum allowed power.

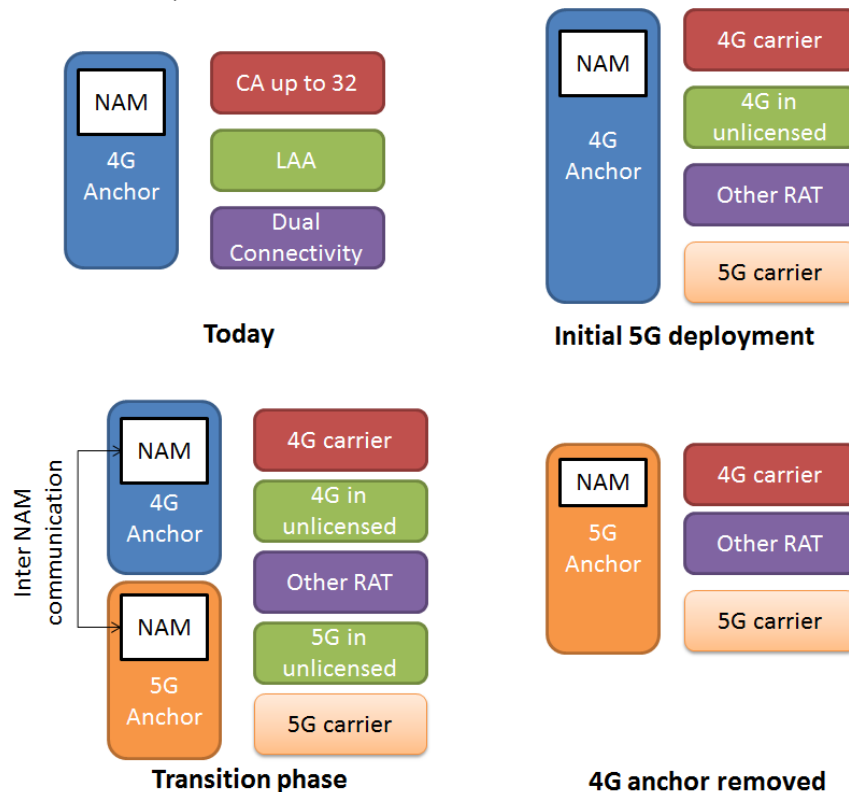

Figure 3: 4G to 5G transition scenario using the management architecture.

The efficient implementation of the aforementioned functionalities ensuring backward compatibility with existing 3GPP system functionality as well as coexistence with legacy Wi-Fi is challenging. If both Wi-Fi access points and LTE eNBs operating in unlicensed bands were managed by a NAM connected to a CSAC, their use of the spectrum use could be coordinated and thus interference could be avoided.

3.1.3 Aggregation Management Architecture as a Building Block for 5G

The proposed management architecture allows various transitions from 4G to 5G. The most likely scenario consists of having 5G radio access anchored to a 4G network to start with, and a smooth transition to a 5G core that could ultimately become the anchor of remaining 4G systems. This is illustrated in Figure 3. In the initial deployment phase when 4G will be the anchor system on which 5G carriers can be attached, the NAM can be hosted by the 4G network equipment and will gather information from the TAM of connected terminals. A terminal with 5G capability could be allocated

5G carriers, (e.g., transmitting in mmWave spectrum). In the transition period where two core systems could coexist, one 4G and one 5G, the respective NAM could coordinate using the inter-NAM communication interface to manage the use of spectrum in the given localized area. Indeed, the proposed management architecture is suited to handling the management of CA (as well as other schemes of spectrum management or joint use of multiple RATs) in the transition from current 4G to future 5G systems.

3.2 Generalized Case, and Discussion of Associated Challenges

The above discussion is related to expansion on classic mobile communications scenarios built out of the 3GPP stream of specifications. The generalized aggregation case is in some respects simpler than this as it is not “bound” to functionalities within a given system and can be (or more accurately, generally must be) performed independently at a higher layer, e.g., through the matching and combining of links capabilities to serve traffic load, performed by the NAM and TAM in Figure 1. However, one important consideration here is how the traffic flows are split and combined at the beginning and end points of the aggregation. As one solution, this splitting and combining can be achieved through introducing a layer of coding to remove the (often insurmountable) complexity of optimally mapping packets to the different and varying rates of the individual radio interfaces, especially if the aggregation is being done between radically different provisioning means.

Two further considerations in such a generalized case include signalling load, and the standardizing of information structures among the systems providing feedback (NAIC, and TAIC via the TAM) and making decisions (NAM and potentially TAM). Regarding signalling, it is noted that signalling load under our proposal is no more extensive than signalling that already exists in LTE, for example. In normal LTE operation, with or without CA enabled, the UE computes and reports CSI and related information regularly to the network, and the network makes decisions accordingly. However, one possible challenge under our proposal is that the collection of such information and decision making based on it is effectively done at a far higher point in the network or inter-network. Nevertheless, we note that servers and link capacities higher up in the network, inter-networks or Internet are able to easily handle far greater amounts of information, so this challenge is surmountable. Moreover, if such signalling load were too great, the NRM instructions to the NAC, and to the TAC through the TAM, could be formulated as policies limiting/aggregating signalling feedback.

Regarding standardization of the information model, this is routine and can be defined similarly to the information model in Section 6 the IEEE 1900.4 standard [4], noting that IEEE 1900.4 is the inspiration for the proposed architecture in this article.

4 Quantitative Analysis of Benefits

Our analysis of the management architecture proposed in this article addresses two aspects: assessment of the concept of CoCA as compared with non-coordinated approaches, and assessment of better coordinated scheduling in the context of CA.

4.1 Coordinated Channel Aggregation (CoCA)

To demonstrate the benefits of CoCA in HetNets through the proposed management architecture, we implement a CoCA mechanism and compare the results of that with some more simplistic ways to allocate channels. The objective of the coordinated mechanism is to allocate the CCs with mini-

mum channel overhead, guaranteeing target throughput to each user through CA. To these ends, we adopt heterogeneous channel feedback through partial feedback selection provided by the best- M selected feedback strategy, where M is the number of resource blocks being reported [6]. Our assessment of the proposal is inherently, therefore, also considering and optimizing feedback. Further, although we are effectively demonstrating a micro-implementation (due to implementation limitations) of our proposed aggregation management architecture within a LTE layered deployment, it is noted that the same implementation could be mapped to generalized layered or otherwise more generalized deployments across multiple RATs and spectrum types.

In order to gather the multiple feedbacks required to optimize the CC allocation efficiently (as well as link adaptation on every CC), we assume that:

- There is communication among the small cells and the macro cells of the HetNet, e.g., through the X2 interface [7].
- All small cell BSs receive the CSI from multiple UEs for their CCs (i.e., within their coverages).
- All small cell BSs share the received CSI with the coordinator (i.e., the macro BS). The coordinator is equivalent to the NAM in this implementation. This aforementioned feedback information collected from the UEs is conveyed by the TAM (at the UE) to the NAM.
- The macro coordinator (NAM) applies the channel allocation algorithm, selecting the CCs for each UE. The resulting decisions are conveyed to and implemented by the NAC and TAC on the network and terminal sides respectively.

The coordinated channel (CCs) allocation is implemented using a distributed stable matching (SM) algorithm, which is of lower complexity than the Hungarian method (HM) [5]¹. For a broader benchmarking of the proposed CoCA technique, we also implement an Auction method (AM) [8]. The objective is to minimize the best- M selected strategy that reflects the feedback overhead subject to a target throughput rate S_k^{QoS} for the user k . Such a solution is important for CA MIMO systems with link adaptation, especially in cases where there are a large number of CCs such that feedback reports need to be reduced. A comparison of the SM and a random matching (RM), i.e., with random channel allocation, and with the aforementioned AM is undertaken.

We test the performance for 96 subcarriers for the case of 3 users present in the system, and $N=5$ and $N=10$ available CCs. We assume that $M \in [1, 2]$ for the following channel conditions:

- Case 1: One user has low SNR (0-6dB) for all CCs, one user has medium SNR (7-14dB) for all CCs and the last user has high SNR (15-20dB) for all CCs.
- Case 2: All users have low SNR (0-6dB) for all CCs.
- Case 3: All users have medium SNR (7-14dB) for all CCs.
- Case 4: All users have high SNR (15-20dB) for all CCs.

In Figure 4, results are presented showing the total M for the case where $N = 5$, plotted against target throughput rate S_k^{QoS} . The solid line corresponds to the SM algorithm CC allocation, while the dashed line correspond to a RM approach and the dotted line the AM approach. For RM, the users are randomly assigned with available CC until they satisfy their throughput constraints. The results

¹ Both HM and SM can solve assignment problems, where SM and AM are considered as game-theory approach as pointed out in [8].

demonstrate the performance of each CC allocation algorithm in terms of overall feedback overhead $\sum \bar{M}$. \bar{M} is a vector containing the M values selected by the UEs of each CC they were assigned to.

As the target throughputs of the users increases we expect a corresponding increase to the overall feedback overhead. The RM algorithm is clearly the least efficient since no optimal allocation decisions are made and the CCs are assigned randomly. Comparing SM and AM, a similar performance is observed, since the algorithms are quite similar. AM seems to slightly outperform SM, mostly in the low SNR case due to the fact that CC allocation is performed after the coordinator has received bids from all users and thus, can allocate each CC to the best UE. On the contrary, under the SM algorithm the best UE for a CC might never request it, if it has already been satisfied. Finally, the increased signalling overhead required for AM compared with SM, while also accounting for the minimal difference in performance, suggests that the SM algorithm is the best choice. This is especially true in cases with a high number of UEs where the impact of signalling overhead is more evident.

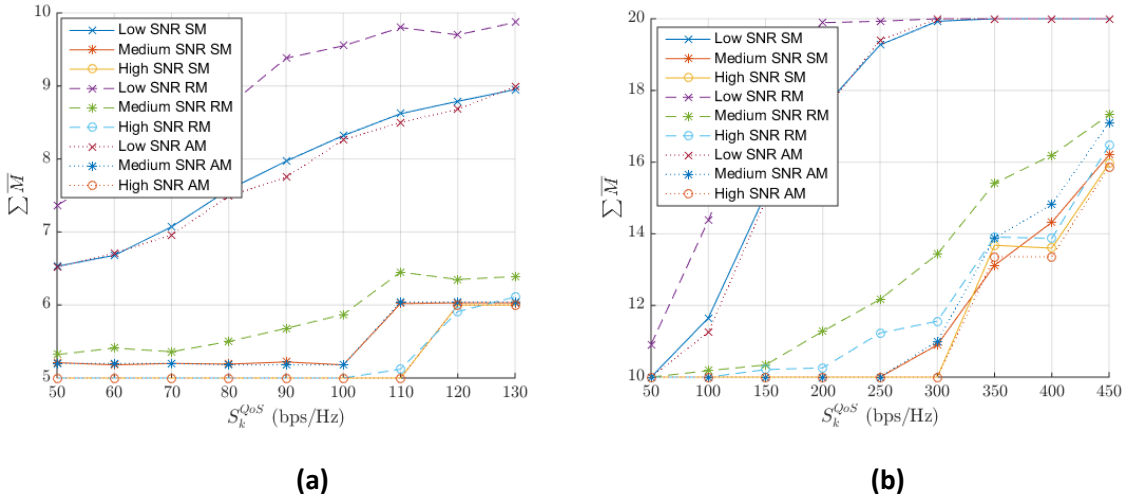

Figure 4: Overall feedback overhead vs. target throughput for $K=3$ users, for the different spectrum assignment techniques SM, RM and AM: (a) $N=5$ CCs, (b) $N=10$ CCs.

4.2 Enhanced Scheduling

As a second example of the benefits of the concept, we argue how such a management architecture can assist scheduling among the carriers that are being aggregated. In order to gain most from CA, the system must be fully aware of its existence and configuration. If CA is used just to provide an additional, separate carrier of the same LTE system, users and network achieve higher throughputs as the bandwidth is wider, however the gain in this case is not as big as it could be. System level simulations have been conducted to prove this hypothesis.

The focus earlier in this section was on how channels can be selected for CoCA, and how this selection can be driven by transmission conditions. In the following text, we show scheduling and its role in transmission effectiveness when carriers are already selected and allocated (through CoCA) for all users that are able to support CA. The previously-assessed algorithms can be used to select channels, while the following algorithm describes how resources within selected channels can be allocated to particular users.

To show the importance of CA-aware architecture we have designed simulation scenarios to analyse system throughput using different variations of the Proportional Fair scheduling algorithm. The case verifies the network's performance with two selected carriers. In the defined network, some users are able to operate in a CA environment, while some of them can use only one carrier (Release 8 compliant terminals).

The Proportional Fair scheduler that is used in these simulations can be configured with two parameters, β and γ . Both of these parameters are used to control fairness of the scheduling. β is related to the historical throughput, while γ is related to the number of currently used CCs. In this scenario, we focus on the β parameter.

Figure 5 shows the cumulative distribution function of the downlink throughput for all non-CA and CA UEs, respectively. It can be seen how changing the β parameter affects throughput for the users. Results are compared with the benchmark case – Round Robin scheduling. If the β value is reduced, some users achieve higher throughputs, but this approach reduces throughput of the users with bad radio conditions such that they might not be able to transmit at all. In this case, the scheduler operates on both carriers separately, and no additional gain from CA is introduced. In order to benefit more from CA, the parameter γ is introduced. This parameter can be used to balance throughput in a similar way to the β parameter. Changing the γ value can favor users with or without support for CA.

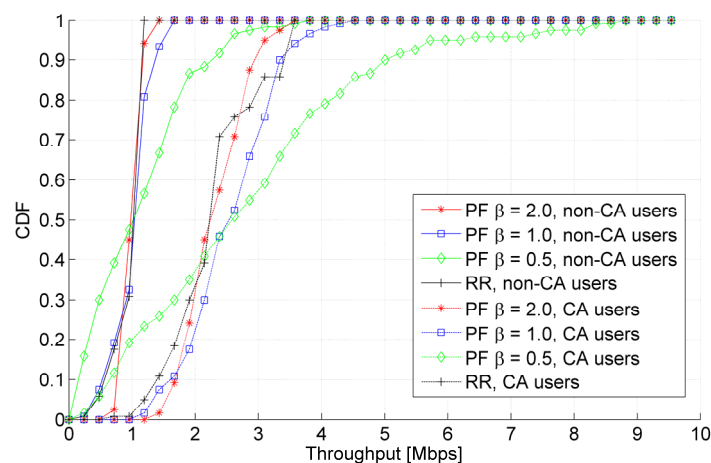

Figure 5: Cumulative distribution function of downlink throughput for non-CA users and CA users.

5 Conclusion

This article has argued for the definition of a management architecture supporting aggregation among heterogeneous spectrum bands and system/link types. It has noted that with increasing fragmentation of spectrum, and the different characteristics of spectrum and networks that will serve future communication systems realizing 5G requirements, systems will need to be able to combine and use these fragmented spectrum and link opportunities in order to realize the capacity and other benefits of 5G.

This article has mapped the proposed management architecture to aggregation scenarios in which it could apply, and has performed simulations and discussed examples to broadly illustrate the work-

ing of the architecture and the benefits of aggregation through such an approach. There are many considerations in the definition of aggregation. These include aspects such as the spectrum bands that can be supported by the different radios and their host terminals, and the ability to aggregate bands and the width of the footprint under which spectrum can be aggregated by systems, among many others. Nevertheless, the architecture we have proposed here, and its associated characteristics, is intended to take into account such considerations in its signalling and aggregation decisions, such that optimal decisions on aggregation can be taken on a system level, compliantly with the capabilities of the networks and terminals that are being served by the architecture.

Acknowledgement

This work has been supported by the “Spectrum Overlay through Aggregation of Heterogeneous Dispersed Bands” project, ICT-SOLDER, www.ict-solder.eu.

References

- [1] R. Zhang, M. Wang, L. X. Cai, Z. Zheng, X. Shen, “LTE-unlicensed: the future of spectrum aggregation for cellular networks,” *IEEE Wireless Communications*, Vol. 22, No. 3, September 2015.
- [2] J. Zander, P. Mähönen, “Riding the data tsunami in the cloud: myths and challenges in future wireless access,” *IEEE Communications*, Vol. 51, No. 3, March 2013.
- [3] J. G. Andrews, *et al.*, “What Will 5G Be?,” *IEEE Journal on Selected Areas in Communications*, Vol. 32, No. 6, June 2014.
- [4] IEEE Std. 1900.4TM-2009, February 2009.
- [5] R. Mochaourab, B. Holfeld and T. Wirth, “Distributed Channel Assignment in Cognitive Radio Networks: Stable Matching and Walrasian Equilibrium,” *IEEE Transactions on Wireless Communications*, Vol. 14, No. 7, pp. 3924-3936, March 2015.
- [6] Y. Huang and B.D. Rao, “Performance Analysis of Heterogeneous Feedback Design in an OFDMA Downlink with Partial and Imperfect Feedback,” *IEEE Transactions on Signal Processing*, Vol. 61, No. 4, pp. 1033-1046, February 2013.
- [7] D059.05.01, X2 Interoperability in multi-vendor X2 HetNets – Rel.5, Small Cell Forum, June 2014.
- [8] E. Z. Tragos, S. Zeadally, A. G. Fragkiadakis and V. A. Siris, “Spectrum Assignment in Cognitive Radio Networks: A Comprehensive Survey,” *IEEE Communications Surveys & Tutorials*, Vol. 15, No. 3, pp. 1108-1135, 3rd Quarter 2013.
- [9] 3GPP TR 36.889 TSG RAN, “Study on Licensed-Assisted Access to Unlicensed Spectrum”, Rel.13, v13.0.0, June 2015.
- [10] 3GPP RP 142286, “New WI proposal: LTE Carrier Aggregation Enhancement Beyond 5 Carriers,” Rel.13, December 2014.

Biographies

Oliver Holland (oliver.holland@kcl.ac.uk) received his Ph.D degree in Telecommunications Engineering from King's College London in 2006. He is a recognized expert and holds numerous leadership positions in spectrum sharing activities, among others. Some of his other research interests include virtualization, transport protocols, green communications, and traffic modeling. Oliver has co-authored over 150 publications, which have been cited more than 1,000 times. He has co-edited two books, published by Springer and Wiley, and co-authored one patent.

Adnan Aijaz (adnan.aijaz@kcl.ac.uk) received the Ph.D degree in Telecommunications Engineering from King's College London (KCL) in 2014. After a post-doctoral year at KCL, he moved to Toshiba Research Europe Ltd. where he currently works as a Research Engineer. His primary research focus is on wireless networking, with emphasis on cognitive radio, sensor networks, 802.11, Internet-of-Things, and more recently, the Tactile Internet. His publications in these areas have featured in internationally renowned conferences and journals.

Florian Kaltenberger (florian.kaltenberger@eurecom.fr) is an Assistant Professor in the Communication Systems department at EURECOM (France) and part of the team managing the real-time open-source 5G platform OpenAirInterface.org. He received his Diploma degree (Dipl.-Ing.) and his PhD both in Technical Mathematics from the Vienna University of Technology 2002 and 2007 respectively. His research interests include 5G and MIMO systems at large, software defined radio, signal processing for wireless communications, as well as channel modeling and simulation.

Fotis Foukalas (foukalas@isi.gr) received his Ph.D. in Informatics and Telecommunications from the National and Kapodistrian University of Athens. His research interests are in communications and networking, optimization and control, cross-layer design and deep/machine learning. He is a senior researcher at Industrial Systems Institute at Athena Research and Innovation Center since January 2016. He has published 20 journals and 35 conferences, having also published four book chapters and one submitted US patent.

Guillaume Vivier (gvivier@sequans.com) graduated from Telecom Paris Tech and received his PhD degree from the University of Pierre and Marie Curie. After various positions in Alcatel and Motorola, he joined Sequans Communications to drive innovation into products. He is currently Director of Advanced Technology and coordinates European and National funded research activities. He recently initiated a 5G activity to prepare future generation Sequans' chipsets.

Mateusz Buczkowski (m.buczkowski@is-wireless.com) is a senior R&D engineer at IS-Wireless with more than four years of experience in wireless communications. His main research interests are in resource management and HetNets. Apart from research Mateusz enjoys developing tools for modeling network behavior on different levels. He obtained his MSc in 2012 from Poznan University of Technology, where he is currently pursuing towards PhD.

Slawomir Pietrzyk (s.pietrzyk@is-wireless.com) is an expert in wireless technologies and the author of the first book on OFDMA, entitled "OFDMA for Broadband Wireless Access", and published in 2006 by Artech House. He holds a Ph.D. degree from the Delft University of Technology in the Netherlands and postgraduate diploma in management from the Warsaw School of Economics. Prior to IS-Wireless, Slawomir worked for T-Mobile and Ubiquitous Communication Program at the Delft University of Technology.