

This electronic thesis or dissertation has been downloaded from the King's Research Portal at <https://kclpure.kcl.ac.uk/portal/>



DEVELOPMENT OF A PSYCHOLOGICALLY-BASED TREATMENT FOR CHRONIC PAIN IN SINGAPORE
PATIENT AND HEALTHCARE PROFESSIONAL INPUTS, THEORETICAL MODEL AND A FEASIBILITY TRIAL

Yang, Su-Yin

Awarding institution:
King's College London

The copyright of this thesis rests with the author and no quotation from it or information derived from it may be published without proper acknowledgement.

END USER LICENCE AGREEMENT



Unless another licence is stated on the immediately following page this work is licensed

under a Creative Commons Attribution-NonCommercial-NoDerivatives 4.0 International

licence. <https://creativecommons.org/licenses/by-nc-nd/4.0/>

You are free to copy, distribute and transmit the work

Under the following conditions:

- Attribution: You must attribute the work in the manner specified by the author (but not in any way that suggests that they endorse you or your use of the work).
- Non Commercial: You may not use this work for commercial purposes.
- No Derivative Works - You may not alter, transform, or build upon this work.

Any of these conditions can be waived if you receive permission from the author. Your fair dealings and other rights are in no way affected by the above.

Take down policy

If you believe that this document breaches copyright please contact librarypure@kcl.ac.uk providing details, and we will remove access to the work immediately and investigate your claim.

**DEVELOPMENT OF A PSYCHOLOGICALLY-
BASED TREATMENT FOR CHRONIC PAIN
IN SINGAPORE: PATIENT AND
HEALTHCARE PROFESSIONAL INPUTS,
THEORETICAL MODEL AND A FEASIBILITY
TRIAL**

Su-Yin Yang

1205153

**A THESIS INCORPORATING PUBLICATIONS
SUBMITTED FOR THE DEGREE OF
DOCTOR OF PHILOSOPHY**

**HEALTH PSYCHOLOGY DEPARTMENT
INSTITUTE OF PSYCHIATRY, PSYCHOLOGY AND
NEUROSCIENCE
KING'S COLLEGE LONDON**

December 2015

Abstract

Background: Many studies in non-Asian contexts have tested psychological approaches in the treatment of chronic pain. However studies in Asia, including Singapore are few.

Aims: This thesis is part of a program of research in the development of an Acceptance and Commitment Therapy (ACT)-based treatment for chronic pain, in its application within an Asian and specifically Singaporean cultural and healthcare context.

Methods: Four distinct phases using a mixed-methods design approach was conducted: (a) A systematic review on the efficacy of psychological treatments for chronic pain in East and Southeast Asia (b) Assessing with semi-structured interviews, patient (N = 15) and health professional views (N = 15) on potential barriers for psychological treatment for chronic pain in Singapore, and views relevant to designing a successful ACT-based treatment for chronic pain (c) Identifying optimal delivery features in a quantitative survey developed from themes generated from the interviews, and a test of the relevance of ACT-related psychological processes in a wider patient sample (N = 200), and (d) Development and feasibility test of a culturally-adapted internet-based ACT trial (N = 33).

Results: Studies included in the systematic review were few and mostly of low quality. Patients and health professionals shared many similar views on psychological treatment barriers and facilitators. Survey results showed that a focus on costs and providing proof of treatment success may increase psychological treatment uptake. The utility of psychological flexibility (PF) was found to be relevant within the sample of chronic pain patients from Singapore. High treatment satisfaction (81.8%), low dropout rates (9.1%) and significant

effects on depression (0.51) and pain intensity (0.39) were demonstrated in the trial.

Conclusions: A culturally-adapted ACT-based treatment examined in the healthcare context of Singapore appears feasible for future development. More effective ways to target outcomes and ACT processes are required.

Table of Contents

ABSTRACT.....	2
TABLE OF CONTENTS.....	4
LIST OF FIGURES	9
LIST OF TABLES.....	10
ACKNOWLEDGEMENT	11
ABBREVIATIONS	13
CHAPTER 1: GENERAL INTRODUCTION	15
1.1 Thesis Overview	17
1.2 Summary of Chapters	18
CHAPTER 2: THE PROBLEM OF CHRONIC PAIN: AN OVERVIEW	20
2.1 Chapter Overview	20
2.2 Definition of Chronic Pain.....	21
2.3 Prevalence of Chronic Pain.....	21
2.4 Economic and Healthcare Burden of Chronic Pain	21
2.5 Impact on Work and Productivity	22
2.6 Efficacy of Medical Treatments	23
2.7 Evolving Views of Chronic Pain	32
2.8 Conclusion	38
CHAPTER 3: THE DEVELOPMENT OF PSYCHOLOGICAL TREATMENTS FOR CHRONIC PAIN	39
3.1 Chapter Overview	39
3.2 The Early Years	40
3.3 The Operant Approach	42
3.4 Cognitive-Behavioural Models	45
3.5 Fear-avoidance Model	51

3.6 Delivery of CBT by other Modalities.....	55
3.7 Other Treatment Approaches.....	60
3.8 Conclusion	61
CHAPTER 4: ACCEPTANCE AND COMMITMENT THERAPY (ACT) AND MINDFULNESS-BASED THERAPIES FOR CHRONIC PAIN	62
4.1 Chapter Overview	62
4.2 A Brief Philosophical Outline of ACT.....	63
4.3 Relational Frame Theory and Rule-governed Behaviour	66
4.4 Psychological Flexibility	69
4.5 Implementing ACT in Treatment	76
4.6 Efficacy of ACT for Chronic Pain.....	77
4.7 Meta-analysis of ACT in General	85
4.8 Challenges of ACT and Suggestions for Future Developments	87
4.9 Mindfulness-based Therapies	90
4.10 Conclusion	94
CHAPTER 5: CONDUCTING PSYCHOLOGICAL RESEARCH IN NON- WESTERN CONTEXTS: THE CASE FOR SINGAPORE	95
5.1 Chapter Overview	95
5.2 Generality of Psychological Theories and Applications.....	96
5.3 Importance of Culture	98
5.4 Extent of ACT Treatment	102
5.5 The Context of Singapore	105
5.6 Psychology in Singapore	107
5.7 Evidence for Psychological Treatments in Singapore	108
5.8 Conclusion	110

CHAPTER 6: PSYCHOLOGICAL TREATMENTS FOR CHRONIC PAIN IN EAST AND SOUTHEAST ASIA: A SYSTEMATIC REVIEW.....	112
6.1 Chapter Overview	112
6.2 Published Paper.....	114
CHAPTER 7: MIXED EXPERIENCES AND PERCEPTIONS OF PSYCHOLOGICAL TREATMENT FOR CHRONIC PAIN IN SINGAPORE: SCEPTICISM, AMBIVALENCE, SATISFACTION AND POTENTIAL	149
7.1 Chapter Overview	149
7.2 Published Paper.....	151
CHAPTER 8: HEALTHCARE PROFESSIONALS' PERCEPTIONS OF PSYCHOLOGICAL TREATMENT FOR CHRONIC PAIN IN SINGAPORE: CHALLENGES, BARRIERS AND THE WAY FORWARD	179
8.1 Chapter Overview	179
8.2 Published Paper.....	181
CHAPTER 9: PSYCHOLOGICAL TREATMENT NEEDS FOR CHRONIC PAIN IN SINGAPORE AND THE RELEVANCE OF THE PSYCHOLOGICAL FLEXIBILITY MODEL	207
9.1 Chapter Overview	207
9.2 Published Paper.....	208
CHAPTER 10: DEVELOPMENT OF THE IACT-CEL INTERVENTION PROGRAM FOR CHRONIC PAIN, RATIONALE, DESIGN, CONTENT AND PROGRAM FEATURES	242
10.1 Chapter Overview	242
10.2 Application of Technology for Psychological Treatment.....	243
10.3 Treatment Rationale: Why ACT?	244
10.4 Delivery Format.....	246

10.5 Behaviour Change Principles.....	247
10.6 Designing and Internet-based ACT Intervention	248
10.7 Cultural Adaptation of ACT Methods for iACT-CEL	250
10.8 Description of iACT-CEL.....	252
10.9 Treatment Content	256
10.10 Chapter Summary.....	264
CHAPTER 11: iACT-CEL: A FEASIBILITY TRIAL OF A FACE-TO-FACE AND INTERNET-DELIVERED ACCEPTANCE AND COMMITMENT THERAPY (ACT) INTERVENTION FOR CHRONIC PAIN IN SINGAPORE	265
11.1 Chapter Overview	265
11.2 Study Aims.....	266
11.3 Methods	267
11.4 Results.....	273
11.5 Discussion.....	281
CHAPTER 12: GENERAL DISCUSSION	286
12.1 Summary of Key Findings	286
12.2 Cultural Sensitivity of ACT Measures.....	295
12.3 Clinical Implications	297
12.4 Limitations.....	298
12.5 Future Steps	299
12.6 Conclusion	300
REFERENCES	301
APPENDIX A. Chapter 7: Participant Informed Consent Form	369
APPENDIX B. Chapter 7: Coding Manual.....	374
APPENDIX C. Chapter 8: Coding Manual	386
APPENDIX D. Chapter 9: Participant Study Invite	405

APPENDIX E: Chapter 9: Questionnaire Pack	406
APPENDIX F: Chapter 10: Design and System Description of iACT-CEL	423
APPENDIX G: Chapter 10: Step by Step Guide to Navigate the iACT-CEL Program	425
APPENDIX H: Chapter 10: iACT-CEL Treatment Protocol (condensed version)	433
APPENDIX I: Chapter 11: Participant Study Invite and Information Sheet	479
APPENDIX J: Chapter 11: Study Information Sheet for Health Professionals	483
APPENDIX K: Chapter 11: Participant Informed Consent Form	488
APPENDIX L: Chapter 11: Items Measuring Treatment Expectations	497
APPENDIX M: Chapter 11: Survey on Program Acceptability and Treatment Satisfaction	499
APPENDIX N: Chapter 11: Satisfaction with Life Scale	501
Other Published Papers	502
1. Acceptance and Commitment Therapy for Chronic Pain.....	503

List of Figures

Figure 2.1: Gate Control Theory Model.....	34
Figure 3.1: Fear-Avoidance Model.....	52
Figure 4.1: ACT Model of Psychological Flexibility	72
Figure 10.1: iACT-CEL Home Page Design.....	253
Figure 10.2: Design of Interactive Elements of iACT-CEL	254
Figure 10.3: Design of Administrator Panel	255
Figure 11.1: Study Flow Diagram.....	273

List of Tables

Table 4-1: Summary of Main Characteristics of Acceptance and Commitment Therapy (ACT) Randomised Controlled Trials (RCTs).....	80
Table 10-1: Core Treatment Content in Module 1.....	259
Table 10-2: Core Treatment Content in Module 2.....	261
Table 10-3: Core Treatment Content in Module 3.....	263
Table 11-1: iACT-CEL Feasibility Study Schedule.....	270
Table 11-2: Participants' Demographics	275
Table 11-3: Participants' Pre-Post Treatment Expectations.....	276
Table 11-4: Program Acceptability and Treatment Satisfaction	278
Table 11-5: Means and Standard Deviations for Outcomes and Process Measures	279
Table 11-6: Mean Differences and Effect Sizes for Baseline to Post-treatment and Baseline to Follow-Up	280
Table 11-7: Proportions of Participants who made Clinically Meaningful Improvement, No Change and Declined	281

Acknowledgements

This candidature has been a humbling, and life enriching experience. My inspiration in the pursuit of success was based on this: *“My motto in life: If you have decided to do something then do it well or don’t do it at all. So whatever I do, I try to achieve and achieve it at a high level.”~Lee Kwan Yew (late)*. This pursuit would not have been possible without the support of the following people:

Firstly, warmest thanks to Professor Lance McCracken, my first supervisor, for his patience, open and nurturing style which challenged and guided the development of ideas for this thesis. His dedication to his work and his students is truly an inspiration.

Special thanks to Professor Rona Moss-Morris, my second supervisor, for providing new insight and expertise that brought this work to a higher level. Thank you for your encouragement and assurance and always knowing the right things to say in any situation.

Thanks also to Dr Angeliki Bogosian who guided and supported much of the qualitative work that is included in this thesis.

My gratitude goes to Dr Vincent Yeo and Ms Alice Yeoh, my reporting officers at Tan Tock Seng Hospital, thank you for believing in me and for all the extra support throughout this candidature. This same gratitude extends to my study sponsor, Tan Tock Seng Hospital for providing the administrative and financial support for this work to be completed successfully.

To Sharul, Linda, Meng Kiat and the rest of the team, thank you for the amazing work you’ve done on the videos and website for the iACT-CEL program. It was a pleasure working with you and the rest of the team. You have contributed a significant part in this academic journey.

To my cousin Brendan, thank you for the audio and IT expertise and the “brain-food” that made some of the tougher times bearable.

I would also like to thank Ee Sally and Laura for their continued encouragement, motivation and being there for me when I needed it most. Special thanks also to my cousin Jen for making the pursuit of this candidature an interesting one.

To the Davidsons, especially John and Sue, thank you for your guardianship and friendship, and for seeing me through from the start of my academic journey in the UK in 1997 till present. The environment at Baysham has contributed much to my success.

Words cannot express the gratitude that I have for my parents Bobby and Gladys for their unconditional support in so many unmeasurable ways. You are the best set of parents any daughter could have.

To my darling husband Kevin, and our three beautiful children, Josiah, Leanne and Joash, thank you for your unconditional love and self-sacrifice in making my academic dream come through.

Last but not least, to my God and creator, thank you for this faith journey and answered prayers. Without You none of this would have been possible.

Abbreviations

Abbreviation	Meaning
A & E	Accident and Emergency
AAQ	Acceptance and Action Questionnaire
AAQ-II	Acceptance and Action Questionnaire-II
ACT	Acceptance and Commitment Therapy
APA	American Psychological Association
AR	Applied Relaxation
Aus.	Australia
BPI	Brief Pain Inventory
BPS	British Psychological Society
BT	Behaviour Therapy
CAQ	Committed Action Questionnaire
CAQ-8	Committed Action Questionnaire-8
CBT	Cognitive Behaviour Therapy
CNS	Central nervous system
CCTs	Controlled clinical trials
CPAQ	Chronic Pain Acceptance Questionnaire
CPAQ-8	Chronic Pain Acceptance Questionnaire-8
CRPS-1	Complex Regional Pain Syndrome-Type 1
DSRB	Domain Specific Review Board
DVs	Dependent variables
EEG	Electroencephalography
FA	Fear-avoidance model
FBSS	Failed back surgery syndrome
FMRI	Functional magnetic resonance imaging
GAD	Generalised anxiety disorder
GP	General practitioner
HPB	Health Promotion Board
iACT-CEL	Internet-delivered Acceptance and Commitment Therapy-Connect Engage Live
IASP	International Association for the Study of Pain
IMMPACT	Initiative on Methods, Measurements and Pain Assessment in Clinical Trials
MBCT	Mindfulness-based Cognitive Therapy
MBRP	Mindfulness-based Relapse Prevention
MBSR	Mindfulness-based Stress Reduction
NNT	Number needed to treat
NSAIDs	Non-steroidal anti-inflammatory drugs
OCD	Obsessive-compulsive disorder
PAD	Peripheral arterial disease
PAS	Pain Association of Singapore
PDN	Painful diabetic neuropathy

PF	Psychological flexibility
PHN	Postherpetic neuralgia
PHQ-9	Patient Health Questionnaire-9
PMC	Pain management clinic
RAP	Refractory angina pectoris
RCTs	Randomised controlled trials
RFT	Relational Frame Theory
SCS	Spinal cord stimulation
SEM	Structural equation modelling
SPSS	Statistical Package of the Social Sciences
SWLS	Satisfaction With Life Scale
TAU	Treatment as usual
TCAs	Tricyclic antidepressants
TCBT	Telephone-delivered Cognitive Behaviour Therapy
TENS	Transcutaneous electrical nerve stimulation
TRENDI	Technologically-savvy Resourceful English-educated Non-western Diverse and economically-Improving
TTSH	Tan Tock Seng Hospital
UK	United Kingdom
US	United States
WEIRD	Western English-educated Industrialised Rich Democratic
WHO	World Health Organisation
WL	Waiting List

Chapter 1: General Introduction

Chronic pain is a complex condition and a perplexing one to treat. The initiating and maintaining factors in chronic pain are often diverse and in some cases can be unknown. Attempts to gain a deeper insight into this condition and find effective ways to treat it have led to the development of numerous theories and models. None of the theories and models however, has been able to comprehensively address the full range of symptoms and impacts experienced by people with chronic pain. Chronic pain remains debilitating for the person suffering from it, frustrating for the medical professional treating it and a significant healthcare burden.

The global prevalence of chronic pain is estimated at 28% of the world's adult population (Elzahaf et al., 2012). In Singapore, the prevalence of chronic pain is estimated at 8.7% of the population, approximately 300,000 adults (Yeo & Tay, 2009). Though lower than the global estimate, this is still a significant proportion of people suffering from chronic pain for a small country like Singapore.

It is now widely recognised, in western industrialised countries at least, that the treatment of chronic pain requires a multimodal approach, with psychological interventions representing a key part of this approach (Gatchel et al., 2014). Singapore is widely renowned in the Southeast Asian region as a country for its state of the art healthcare facilities, well-trained healthcare professionals, excellent service delivery and medical research. However its reputation for providing psychological intervention appears less known. Despite the extensive literature that supports the psychological management of chronic pain (Williams et al., 2012); the provision of this treatment remains low in Singapore (Tan et al, 2009). In the area of mental health treatment, there is

some recognition and acceptance of psychological intervention, yet it is not clear that this acceptance applies within treatments for physical health problems, such as chronic pain.

System barriers within current healthcare organisations, a lack of training and education in chronic pain in medical schools, lack of knowledge and experience among health professionals, inadequate information on psychological treatments and chronic pain provided to the public, among other cultural and social factors could be some possible reasons for the low provision, and uptake of psychological treatments in Singapore. As one example, professional psychological societies in the United States (US), United Kingdom (UK) and Australia (Aus.) promote, register, and certify psychologists to practice in the country, govern the standard of training, and crucially promote the proper development of applications of psychology, such as in healthcare. These functions are not provided for practicing psychologists in Singapore.

Many studies, including more than 40 randomised controlled clinical trials (RCTs), in Europe and North America have tested psychological approaches in the treatment of chronic pain, however studies in Asia, including Singapore are few (Eccleston et al., 2009; Williams et al., 2012). Much of our understanding about the psychosocial influences on chronic pain, the delivery of psychological treatment and measures of treatment outcomes stem mainly from data collected from settings in Western countries (Henrich et al., 2010). Differences in cultural, environmental and societal influences on healthcare systems, health professional practices, the understanding of chronic pain and how it should be managed prevent clear direct extrapolation from western data to Asian countries. Similarly, extrapolation of data from one Asian country to another is equally uncertain for the same reasons. A lack of data specific to local

populations in Asia has resulted in gaps in understanding of issues surrounding the psychological treatment of chronic pain in this part of the world. In particular, the state of current provision of psychological treatments, potential barriers to these, relevance of psychological theories and models related to chronic pain in these populations, and efficacy of psychological treatments in these contexts, are not known.

1.1 Thesis Overview

This thesis represents a series of investigations that were designed to be culturally sensitive and aimed to support the development of a psychologically-based treatment for chronic pain in Singapore. The studies described here form a program of research into the development of updated, theoretically-coherent, and evidence-based psychological treatment for chronic pain in Southeast Asia and within a specifically Singaporean cultural, national and healthcare context. The specific treatment model chosen for this development work is Acceptance and Commitment Therapy (ACT). ACT is a form of cognitive behavioural therapy that uses acceptance and mindfulness based methods to increase psychological flexibility (PF), as a means for promoting better health, wellbeing, and daily functioning. The overarching aim of this thesis is concerned with the transferability of this treatment, from the settings where it has been currently developed and tested in a new setting, in Singapore. A step-by-step process was planned and subsequently executed to achieve this aim successfully.

The first step within the studies of this thesis was to identify the current status and efficacy of psychological treatment for chronic pain in East and Southeast Asia. The second step was to explore and identify potential barriers and facilitators for psychological treatment for chronic pain in Singapore. Views relevant to implementing a successful psychological treatment for chronic pain

were sought from treatment users (people with chronic pain who were seeking treatment) and treatment providers (health professionals), people with first hand experiences at receiving and delivering treatment. A third step included examining these perceived treatment barriers and facilitators, or treatment needs, and the relevance of the PF model in a wider sample of people with chronic pain from this same population of people, from both tertiary care and community settings. A final step involved the design, development and initial testing of a mixed face-to-face and internet-based treatment, of culturally adapted version of ACT (iACT-CEL), for a sample of people with chronic pain in Singapore.

1.2 Summary of Chapters

A total of 12 chapters complete this thesis. From here on, Chapter 2 summarises the nature of chronic pain as a problem and the burden it imposes. Chapter 3 addresses the psychological treatment models that have contributed to the understanding of chronic pain during the past four decades. Chapter 4 addresses the theoretical and treatment model of ACT for chronic pain. Chapter 5 examines Singapore as the context of this research. Chapter 6 includes a systematic review of psychological treatments for chronic pain in East and Southeast Asia (published paper, *International Journal of Behaviour Medicine*). Chapter 7 includes a qualitative study of patients' perceptions and experiences of psychological treatment for chronic pain in Singapore (published paper, *Pain Medicine*). Chapter 8 includes a qualitative study of health professionals' perceptions of psychological treatment for chronic pain in Singapore (published paper, *Disability and Rehabilitation*). Chapter 9 includes a quantitative study of psychological treatment needs for chronic pain and relevance of the PF model

in a sample of people with chronic pain in Singapore (published paper, Pain Medicine).

Chapter 10 describes the background to the design and development of the iACT-CEL program, including the technology used in its development. Chapter 11 discusses the feasibility of the iACT-CEL intervention in a sample of people with chronic pain in Singapore (submitted paper). Finally, Chapter 12 summarises the key findings from the five studies reported here, and discusses the broader practical and clinical implications of these findings to the understanding and delivery of psychological treatment for chronic pain in Singapore.

Chapter 2: The Problem Of Chronic Pain: An Overview

2.1 Chapter Overview

This chapter discusses the (a) nature of chronic pain as a health care problem, including its economic impacts and impacts on work and productivity and (b) the efficacy of common medical approaches to chronic pain. Evolving views of chronic pain which includes a brief review of The Gate Control Theory and the Neuromatrix of Pain are also included in this chapter.

2.2 Definition of Chronic Pain

Chronic pain, typically pain that lasts beyond the three-month time period required for most injuries to heal, is a significant health problem by any estimation. Consensus reached among researchers and clinicians with experience in the pain field, broadly define pain as “an unpleasant sensory and emotional experience associated with actual or potential tissue damage, or described in terms of such damage” (International Association for the Study of Pain (IASP) Taxonomy, 1994). By this definition, chronic pain is not simply a physical condition but a combination of both a physical and emotional experience. Chronic non-malignant pain broadly includes chronic musculoskeletal pain (low back pain, spinal pain, arthritis, and myofascial pain), neuropathic pain, visceral pain, and chronic headache, among other disease-related pains.

2.3 Prevalence of Chronic Pain

Recent estimates place the prevalence of chronic pain at 28.0% of the world’s population (Elzahaf et al., 2012). In the US alone, data suggest rates as high as 30% to 40% of the adult population (Johannes et al., 2010), while similar survey methods suggest a more modest prevalence of 19% in Europe (Breivik et al., 2006; Reid et al., 2011). There are currently no comprehensive statistics from Asia, but in individual countries across East and Southeast Asia, estimates of chronic pain prevalence range from 7% to 15% of the population (Cardosa et al., 2008; Nakumara et al., 2014; Yeo & Tay, 2009). By any of these estimates, the prevalence rate for chronic pain is high worldwide, making chronic pain a global healthcare priority.

2.4 Economic and Healthcare Burden of Chronic Pain

Chronic pain is associated with significant personal and societal costs, including both healthcare and work disability costs. In 2010 alone, it was reported that US\$16.4 billion was spent annually in the US just on pharmaceuticals for pain management, with US\$2.9 billion spent on spinal related surgeries due to pain, and an estimate of US\$18.9 billion for disability compensation (Turk & Theodore, 2010). Also in the US, additional healthcare costs for pain and the value of lost productivity due to pain, was reported to be higher than US\$250 billion (Gaskin & Richard, 2012). In the UK, the annual overall cost for back pain alone was estimated at £12.3 billion (Maniadakis & Gray, 2000) with an estimate of £584 million spent on prescription analgesics, and an annual cost of £4.6 million spent on general practitioner appointments (Belsey, 2002; Maniadakis & Gray 2000).

Typical healthcare costs for people with chronic pain are at least 2.6 times higher than for those without chronic pain, with people with pain seeking a higher volume of services, seeing more numerous health care providers, and on more occasions (Moore et al., 2013). In the US, ten extra physician visits per person are made annually (Schaefer et al., 2011), similar to the estimated eight extra physician visits per person made annually in Europe (Frohlich et al., 2006). Healthcare expenditures for managing chronic pain are high, and based on current trends these do not appear likely to reduce soon.

2.5 Impact on Work and Productivity

Chronic pain is a significant impediment to personal vocational achievements. The impacts of pain on daily life, including work attendance and productivity have also been reported in a number of studies (Currow et al., 2010; O'Brien & Breivik, 2012; Raftery et al., 2011). People who experience severe pain are two to five times more likely to report interference with work,

and an experience of greater pain intensity is associated with greater work limitations (Boulanger et al., 2007; Moulin et al., 2002).

A population survey in the UK reported that 44% of working adults with severe pain had difficulty working and approximately 41% were on state benefits (Morgan et al., 2011). Approximately 26% of chronic pain patients in a large European population survey felt that chronic pain had a significant impact on employment, with 19% of respondents reporting a loss of job due to pain (Breivik et al., 2006). In a community sample in Germany, it was reported that workers suffering from chronic pain contribute to an estimated loss of 30 work days a year (Frohlich et al., 2006). The experience of severe chronic pain also significantly reduces workplace participation and increases work absenteeism and “presenteeism” (Langley et al., 2010; Patel et al., 2012). Presenteeism is the situation of an employee being present at work but not being able to function at the level required to complete work tasks to an expected standard.

2.6 Efficacy of Medical Treatments

Data extracted from the Bone and Joint project in collaboration with the World Health Organisation’s (WHO) global burden of disease 2000 project, revealed that the most common complaints of pain are musculoskeletal in nature, and chronic low back pain is the most common of these (Woolf & Pfleger, 2003). In the medical field, attempts at achieving pain relief for these types of conditions, with chronic low back pain as a key example, have led to an expanding array of medical treatments including pharmacological treatments, interventional pain therapies such as injection therapies, surgical interventions and implantable devices. Data available on the efficacy of such treatments however have been mixed.

Pharmacology

Pharmacological treatment has been widely prescribed for the relief of pain symptoms related to chronic pain. Categories of pharmacological agents commonly used in the treatment of chronic non-malignant pain include nonsteroidal anti-inflammatory drugs (NSAIDs), adjuvants such as antidepressants and anticonvulsants and opioids (Lynch & Watson, 2006). This section will focus on the general efficacy of common pharmacological treatments on selected pain conditions.

NSAIDs. NSAIDs are commonly prescribed for pain with an inflammatory component (Ho & Siau, 2009). Treatment guidelines for the management of chronic low back pain in primary care support the use of NSAIDs in the symptomatic relief of low back pain (Airaksinen et al., 2006; Koes et al., 2001, Koes et al., 2006; van Tulder et al., 2006). Thus far, reviews have documented small effects for NSAIDs in the short term in patients with acute and chronic low back pain without sciatica (Roelofs et al., 2008; White et al., 2011). Other reviews revealed low quality evidence supporting the efficacy of NSAIDs over placebo in the treatment of chronic low back pain (Kuijpers et al., 2011) and that no one type of NSAID appears better than another (Roelofs et al., 2008).

Similarly, a recent Cochrane review found a lack of good quality data surrounding the efficacy of NSAIDs in the treatment of neuropathic pain, leading the authors to conclude that there is currently inconclusive evidence supporting the use of NSAIDs in the treatment of neuropathic pain (Moore et al., 2015). In the treatment of osteoarthritis, topical NSAIDs have been demonstrated to be better than placebo in providing pain relief for people with osteoarthritis (Derry et al., 2012). The strongest efficacy was found for Diclofenac, with a number

needed to treat (NNT) for 50% pain relief at 6.4 in solution form and 11.0 in gel form (Derry et al., 2012).

The use of NSAIDs in the treatment of chronic low back pain and neuropathic pain appear limited. Adverse effects such as abdominal pain, diarrhoea, dry mouth, oedema, ulceration and gastro-intestinal bleeding have also been associated with NSAID use (Kuijpers et al., 2011).

Antidepressants. The use of adjuvants such as antidepressants in treating neuropathic pain is well established (Attal et al., 2006). Evidence based guidelines support the use of tricyclic antidepressants (TCAs) as first line treatment for neuropathic pain, with the evidence for TCAs strongest in postherpetic neuralgia (PHN) and painful diabetic neuropathy (PDN) (Finnerup et al., 2005; Sindrup et al., 2005). A meta-analysis of 61 randomised controlled trials (RCTs) concluded that TCAs are efficient to treat neuropathic pain, and overall NNT was 3.6 (95% CI: 3- 4.5) (Saarto & Wiffen, 2007).

Evidence has been mixed with regards to the efficacy of antidepressants in the treatment of chronic low back pain (Kuijpers et al., 2011). A small number of studies have shown that TCAs and tetracyclic antidepressants produced moderate symptom reductions for patients with chronic low back pain, independent of depression (Staiger et al., 2003), and small but significant effects demonstrated in reducing pain compared to placebo (Salerno et al., 2002). Other reviews however, concluded that antidepressants have no effect on pain relief for chronic low back pain (Kuijpers et al., 2011; Urquhart et al., 2008).

The use of antidepressants has been associated with adverse effects such as sedation, dry mouth and constipation (Lynch & Watson, 2006), with physical dependence and withdrawal symptoms known to be induced in

patients when antidepressants are abruptly stopped (Zajack et al., 1997). Overall findings imply that only some, but not all patients with particular pain mechanisms would benefit from the use of antidepressants. Those more likely to benefit are those suffering from neuropathic pain.

Anticonvulsants. Anticonvulsants are another type of adjuvants that also appear to work best for patients suffering from neuropathic pain (Wiffen et al., 2005). The two most frequently prescribed anticonvulsants in the treatment of neuropathic pain are Gabapentin and Pregabalin (Attal et al., 2010). The NNT recorded for Gabapentin was 4.3 for PHN and 6.4 for PDN and the NNT for Pregabalin was 4.2 for PHN and 4.5 for PDN (Finnerup et al., 2010). Pregabalin was shown to have good efficacy for PHN, and efficacious in providing pain relief and improving quality of life in PDN (Attal et al., 2010).

Early evidence reported a similar general efficacy for antidepressant and anticonvulsant agents in the treatment of neuropathic pain, with the use of anticonvulsants associated with fewer side effects (Lynch & Watson, 2006; McQuay, 2002; Morello et al., 1999). A recent systematic review that compared pooled data of six trials, comparing a type of TCA with Gabapentin or Pregabalin, found similar proportions of patients receiving 50% pain relief with both drug types and similar proportions discontinuing use of the drugs due to side effects (Finnerup et al., 2010).

At present, the overall efficacy of pharmacological treatments in providing pain relief for neuropathic pain remains limited (Finnerup et al., 2010), with common adverse effects such as dizziness, ataxia, confusion and a change in gait patterns associated with the use of anticonvulsants (McQuay, 2002; Rice et al., 2001).

Opioids. Opioids have been the mainstay treatment for cancer pain and have also been frequently prescribed in the management of acute pain (Vallejo et al., 2011). The efficacy of opioids in the treatment of chronic non-malignant pain is less well established. Mixed evidence for the short term efficacy of opioids on pain and function, compared to placebo in the treatment of chronic non-malignant pain has been demonstrated (Chaparro et al., 2013). Evidence for the long term use of opioids and for the potential harms associated with it appears to be lacking (Chou et al., 2015).

A recent Cochrane review that included 15 studies of patients with back pain, suggested that opioids can provide long-term pain relief in selected patients with no history of substance addiction or abuse (Noble et al., 2010). Further studies are however needed to determine which type of patients will benefit most from opioid treatment. In a subsequent review, Nampiaparampil and colleagues (2011) suggested that the evidence supporting opioids in providing pain relief and functional improvement in patients with low back pain is of relatively low quality. Opioids were also associated with high treatment dropout rates due to insufficient pain relieve and adverse effects such as constipation, sedation, nausea and vomiting. With increasing evidence demonstrating a relationship between long-term use of opioids and increased risks of harms such as opioid abuse, fractures and myocardial infarction (Chou et al., 2015), current evidence for the use of opioids in the treatment of low back pain do not support their use beyond a 12-month period (Ho et al., 2013).

In spite of the widespread use of opioids in the management of chronic non-malignant pain conditions (Sullivan et al., 2008), there is a paucity of well-designed studies to make strong evidence based recommendations, and also a general lack of evidence for their use in the treatment of particular chronic pain

conditions such as neck pain, chronic pelvic pain, fibromyalgia and facial pain (Ho et al., 2013).

Injection Therapies

Injections therapies are a common procedure for chronic pain in hospital-based pain services, particularly for back pain. Even so, general consensus suggests that there is limited evidence for the efficacy of injection therapies in the treatment of subacute and chronic low back pain (Staal et al., 2008). Data obtained from RCTs demonstrated limited support for most injection therapies in treatment (Chou et al., 2009a), with conflicting evidence found for epidural steroid injections (Manchikanti et al., 2015; Mirza & Deyo, 2007). Variability in methods, including patient inclusion criteria, injection techniques used, treatment comparison conditions, and outcomes assessed, appear to have contributed to inconsistent results across trials (Benoist et al., 2012; Benyamin et al., 2012; Pinto et al., 2012; Staal et al., 2008). Again, the use of injection therapies appears popular with many specialist practitioners, even with the lack of evidence. Their use is therefore a kind of contentious issue between clinicians who espouse contrasting approaches. Perhaps as a result of this, and also feeding into the controversy, clinical practice guidelines provide conflicting recommendations regarding the use of injection therapies for the treatment of pain (Chou et al., 2009a; Savigny et al., 2009).

Surgical Interventions and Implantable Devices

Generally speaking, studies supporting the efficacy of surgical interventions and implantable devices on the treatment of chronic pain are also limited. Specific to surgical interventions, reviews have mostly assessed the efficacy of lumbar fusion on chronic low back pain (Ibrahim et al., 2008). A meta-analysis comparing lumbar fusion and non-surgical interventions of

cognitive therapy and exercise for chronic low back pain found only marginal, non-significant improvements in disability following lumbar fusion surgery (Ibrahim et al., 2008). Lumbar fusion was not superior to cognitive interventions and exercise in providing pain relief and improving function in patients with chronic low back pain. Mirza and Deyo (2007), demonstrated that compared to unstructured nonsurgical care for chronic back pain, lumbar fusion surgery had better efficacy but was not superior to structured cognitive behaviour therapy (CBT). However, methodological issues present in the reviewed trials prevent firm conclusions.

A recent Cochrane review that included two studies comparing multidisciplinary rehabilitation with lumbar fusion and insertion of disc prosthesis, demonstrated no difference between these interventions on outcomes of pain, disability and work in samples of patients with chronic low back pain (Kamper et al., 2015). Results were however inconclusive, due to the small number of low quality trials included in the review. Other recent reviews concluded that lumbar fusion is not more effective than conservation or non-surgical interventions in reducing disability (Bydon et al., 2014; Saltychev et al., 2014). Even after 'successful' surgical trials, higher incidences of adverse events, pain and disability were also found with patients who had undergone surgery. In consideration of the significant risks associated with surgical interventions, the current available evidence does not support routine lumbar fusion for the treatment of chronic low back pain (Saltychev et al., 2014).

Spinal cord stimulation (SCS) implants were first introduced in 1967 (Shealy et al., 1967). This surgery that involves implanting an electrical stimulation at the dorsal column to treat chronic intractable pain, including failed back surgery syndrome (FBSS), complex regional pain syndrome type 1 (CRPS-

1), ischaemic limb pain, angina, and other forms of neuropathic pain such as phantom limb pain, PHN and PDN is usually delivered within a multidisciplinary pain management setting (Barolat, 2000). SCS is usually not prescribed as a first line of treatment but prescribed after more conservative treatments have failed (Vannemreddy & Slavin, 2011). Expected benefits from SCS included a reduction in pain and use of pain medications and an improved quality of life (Simpson et al., 2009).

An early review demonstrated only 'moderate' evidence for the use of SCS to treat chronic back and leg pain secondary to FBSS (Taylor et al., 2004). A Cochrane review conducted around the same time concluded that the evidence for SCS for FBSS was limited (Mailis-Gagnon et al., 2004). A more recent extensive systematic review that included 11 good quality trials, found SCS to be more effective than conventional medical treatments and re-operation in reducing pain in FBSS and CRPS-1 (Simpson et al., 2009). It is however unclear whether these benefits can be equally applied to other neuropathic pain conditions.

In general, studies that have investigated the efficacy of SCS for chronic pain in the recent past have lacked rigour, included mostly small sample sizes, with few RCTs (Cameron, 2004). However, some more positive results have come from health economic analyses. One advantage of SCS may be its long-term efficacy and cost-effectiveness for healthcare over conventional medical treatments (Kemler & Furne, 2002; Taylor et al., 2004). Recent cost-effectiveness studies demonstrated cost effectiveness of SCS with conventional medical treatments over conventional medical treatments alone for FBSS, CRPS, peripheral arterial disease (PAD) and refractory angina pectoris (RAP) (Kumar & Rizvi, 2013). SCS also remained cost-effective as an adjunct to

conventional medical treatment and reoperation for FBSS (Taylor et al., 2010). Thus even though initial costs may be high, SCS treatment may be more cost-effective in the long-term (Manca et al., 2008). Even so the efficacy question remains uncertain.

Other Medical Treatments

Apart from the medical treatments already reviewed, physical therapies, including transcutaneous electrical nerve stimulation (TENS), ultrasound, shortwave, microwave, laser, superficial heat and cold treatment as well as physiotherapy are some other types of medical and physical treatments that are usually prescribed in the management of chronic pain (Melzack & Wall, 2003). These treatments are too extensive to be reviewed here.

Summary of Evidence for Medical Treatments

In general, current trials addressing the efficacy of medical treatments for chronic pain appear to include mostly small sample sizes and comparisons with inactive treatments or placebo rather than an active control condition. They have varied study methodology, treatment measures, preparations, formulation, applications and schedules of the targeted treatment. Many trials were also reported to be of low quality. These factors in addition to mixed results obtained from studies have contributed to the difficulty in drawing firm conclusions regarding the efficacy of medical treatments for chronic pain. It appears from a review of these treatments that effective treatment of chronic pain for many people will require more than unimodal treatments of medications, injection therapies or surgical interventions. Many experts take this to mean that multimodal therapies are needed, particularly therapies that address psychosocial influences and also target psychosocial and functional impacts.

2.7 Evolving Views of Chronic Pain

Historically, pain was typically regarded as a sign of actual tissue damage and as a gauge of injury severity. From this view, the amount of pain experienced and reported was deemed directly proportional to the amount of tissue damage. It was therefore assumed that pain should subside as the physical pathology that created it resolved. We now know that a standard finding in pain research is that events in life often do not reflect these assumptions. It is relatively commonplace to see patients who experience no disability in the context of extensive tissue damage with clear basis for pain, while others report extensive disability in response to what appears to be a minor injury and an unconvincing basis for significant pain (Gatchel et al., 2007). In fact, it is in these inconsistencies that the nature of chronic pain appears, with all of its potential frustrations for those who experience it as well as those who try to remedy it.

Gate Control Theory

The formulation of the Gate Control Theory (Melzack & Wall, 1965) in the mid-20th century was a landmark event in pain research and treatment. It helped lead the way for researchers and clinicians alike to consider pain from a biopsychosocial perspective, and helped to answer some of the inconsistencies between the pain experience and extent of tissue damage.

Stepping back in time, early work by Descartes (as cited in Melzack & Wall, 1965) attempted to explain the experience of pain through a 'pain pathway' projecting from the periphery to the cerebral cortex by way of the spinal cord, brainstem and thalamus. Notions such as this led to an approach referred to as "specificity theory," which proposed that body tissue contains a variety of specific pain receptors that projected via a direct connection to a pain

centre in the brain. Pain is experienced when these receptors are stimulated by a noxious stimulus. Melzack and Wall (1965) argued against the simplicity of this theory. Using the example of Beecher's study (as cited in Melzack and Wall, 1965), where wounded soldiers with extensive wounds being evacuated from combat settings continued to deny the experience of pain, they concluded that psychological variables likely contributed to perceived pain, and that noxious stimuli could be prevented from producing an experience of pain, given the presence of certain other pain modulating situations.

The Gate Control Theory (Melzack & Wall, 1965) was proposed to explain the experience of pain, particularly with respect to its loose relations with injury or tissue damage. It was suggested that noxious stimulation from the periphery evokes nerve impulses that are transmitted to three systems in the spinal cord: the cells of the substantia gelatinosa (SG) and the central transmission (T) cells in the dorsal horn and fibres in the dorsal-column that project toward the brain. In their formulation, the SG functions as a gate control system that modulates input from the large (L) and small (S) sensory fibres before they influence the T cells; T cells trigger neural mechanisms which makes up the action system responsible for response and perception. Pain is determined by the interaction of these three systems. Figure 2.1 shows the model of the Gate Control Theory of Pain.

Figure 2.1: Gate Control Theory of Pain Model (Melzack & Wall, 1965).

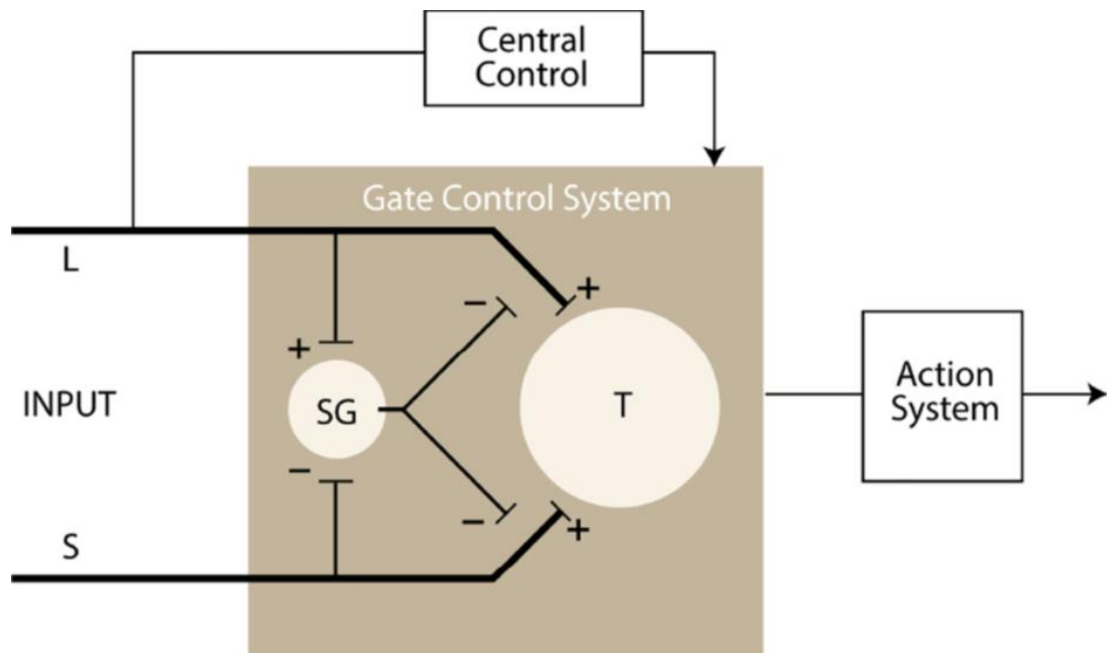

From "Melzack, R., & Wall, P.D. (1965). *Pain Mechanisms: A New Theory. Sci*, 159, p.975"
Copyright by the American Association for the Advancement of Science. Used with permission.

According to the theory, pain control may be achieved by selectively enhancing L input and decreasing S input leading to the gate being closed and pain abolished. Any lesion that impairs the normal flow of peripheral impulses to the gate control system could open the gate. Any central nervous system (CNS) condition that increases the flow of descending impulses from the brain could close the gate. Once again, according to the theory, psychological factors such as attention and emotion can influence perceptions and the experience of pain via the gate control system, potentially increasing pain by opening gating mechanisms or decreasing pain by closing these same mechanisms.

The Gate Control Theory helped researchers and clinicians to accommodate key observations: that non-noxious stimuli can produce pain, that tissue damage at a specific area may not correspond to the same pain location, that pain can persist beyond the period of tissue healing, that pain location and the nature of pain can change over time without clear change in the underlying

physical circumstances, and that conventional pain treatments can be properly delivered yet produce no beneficial effect (Melzack & Wall, 1965). The Gate Control Theory was successful at the time in proposing a plausible mechanism for explaining the rather complex experiences surrounding chronic pain.

The past 50 years in pain research following the Gate Control Theory has seen much progress within the biopsychosocial model of pain, as well as in other areas of medicine. Pain is now recognised as a complex psychological experience that encompasses not only biological and neurophysiological components but also takes into consideration cognitive, affective and environmental determinants of pain expression and the pain experience (Hadjistavropoulos et al., 2011). Over the last 50 years, updates to the Gate Control Theory, including different and newer neurophysiological processes have appeared.

Neuromatrix of Pain

Expanding from the Gate Control Theory, Melzack (2001) proposed that an understanding of brain functions, with less emphasis on the spinal cord, was also important in understanding pain. More or less applying concepts from cognitive neuroscience network theory (Rumelhart et al., 1986). Melzack (2001) proposed that pain could be considered a multi-faceted experience produced by characteristic 'neurosignature' patterns of nerve impulses generated by a widely distributed brain neural network, the 'neuromatrix'. The theory maintains that the 'neuromatrix' operates on processes of the thalamocortical (cognitive-evaluative), somatosensory (sensory-discriminative) and limbic (motivational-affective) functions, with an interaction of the components of these three processes contributing to the pain experience (Casey, 1982). The 'neurosignature' which lies within the 'neuromatrix' registers all qualities of

human psychological experience, including pain and affective states and is influenced by genetic make-up as well as cognitive, sensory and affective experiences that are unique to each individual. Although the 'neuromatrix' and 'neurosignature' are to an extent genetically pre-determined, new learning and experience can alter the experience of pain (Merskey, 1991).

The concept of the 'neuromatrix' of pain appears to be supported by results from imaging studies that have demonstrated the involvement of the thalamocortical (Baliki et al., 2006; Borsook et al., 2010; Seminowicz et al., 2011; Tracey & Mantyh, 2007), somatosensory (Jones et al., 1991; Talbot et al., 1991) and limbic circuits (Lang et al., 2009; Neugebauer et al., 2004) in the brain in relation to the pain experience. Such studies have used non-invasive imaging techniques such as electroencephalography (EEG), functional magnetic resonance imaging (fMRI) and other imaging techniques to investigate the neural basis of pain perception.

Functional imaging has to an extent demonstrated that the brain responds to noxious stimuli. The practical usefulness of this is perhaps yet to be seen. At best, we now have more or less identified pattern of brain responses in people with chronic pain, we know which parts of the brain regions might respond to pain. As yet, we still do not know the answer to why these brain regions function this way, detailed mechanisms of how they function, how and whether these systems differ with different types of chronic pain patients and what, if any, of the brain pathways can modify the 'neuromatrix' to alter the pain experience (Derbyshire, 2000). In attempts to answer these questions, neuropsychological research introduced what has been named the 'Pain Matrix'.

Pain Matrix

The 'Pain Matrix', was proposed as a kind of more specific version of the general 'neuromatrix.' The notion behind the 'Pain Matrix' was that brain responses elicited by nociceptive stimuli will trigger a specific network of neurons to process only pain (Brooks & Tracey, 2005) and that functional imaging may be used to explain the anatomy of different aspects of pain (Ingvar, 1999; Tracey & Manyth, 2007).

There is however contradictory evidence surrounding the 'Pain Matrix'. Results from current functional neuroimaging techniques imply that the 'Pain Matrix' may not be as exclusively related to the perception of pain as assumed. Several studies have demonstrated that the EEG and fMRI responses produced by both nociceptive and non-nociceptive stimuli are very similar (Kunde & Treede, 1993; Liu et al., 2008). EEG studies have also shown in many circumstances, that the level of elicited brain responses do not always relate to intensity of the nociceptive stimulus or to perceived pain (Clark et al., 2008). Further, a small quantity and scarce distribution of nociceptive-specific neurons in a number of the cortical regions constituting the pain matrix suggest that nociception may not be represented as a distinct sensory modality in these regions (Andersson & Rydenhag, 1985). Contrary to the 'Pain Matrix', therefore, it would seem that neural activities of nociceptive stimuli do not appear to specifically reflect only nociceptive specific brain activities but non-nociceptive ones as well (Iannetti & Mouraux, 2010). The concept of a 'pain matrix' is therefore challenged.

Beyond the controversies behind neurophysiological theories, certainly imaging studies have furthered our appreciation for the complexities of how the brain participated in processes of detection and response to painful events. At

the same time, pain is not merely in the brain, so to speak, and even with the remarkable commotion and resources devoted to the role of the brain, psychosocial influences remain key, a topic that is addressed in the next chapter.

2.8 Conclusion

Our understanding of the nature of chronic pain may have evolved in the last 50 years since the introduction of the Gate Control Theory in 1965. While we may not yet have a fully satisfactory scientific account of pain, it certainly is clear that pain is a complex experience with important psychological or psychosocial components. What is also certain is that high prevalence rates of chronic pain worldwide, high healthcare and productivity costs, negative impacts on both the individual and society and limited treatment efficacy of current available medical treatments, all point to the fact that chronic pain is an important problem in need of solutions. Chronic pain represents a significant healthcare burden by any standard and one that is likely to grow with an ageing population.

Based on the summary of the problems and its treatments presented here, treatments aimed to reduce pain by medical or physical modalities appear to only work for a limited number of people and to a limited degree. Effective treatment of chronic pain continues to be a challenge within the medical and psychological approaches today. Despite the advancement in science and technology, truly significant large scale advances seem difficult to achieve. It may be that we have not been asking the best questions in our approach to chronic pain. Perhaps it no longer about asking the simple question of “what works?” but broader questions of “what works, for whom, when, for what purpose, and under what circumstances?”

Chapter 3: The Development of Psychological Treatments for Chronic Pain

3.1 Chapter Overview

In Chapter 2, the nature of chronic pain as a health care problem, the efficacy of medical approaches to chronic pain and evolving views of chronic pain were discussed. This chapter focuses in further detail on psychological approaches to chronic pain, in particular, the aims, methods, and evidence for the operant and the cognitive-behavioural approaches. Development of psychological treatment in the early years prior to the mid-1960s is briefly reviewed within a chronological account.

As should be clear from the previous chapter, the impacts of chronic pain on society, the individual and their loved ones are considerable. It also should be clear that most people gain only modest benefits from conventional medical treatments including medications, injection therapies, surgeries and implantable devices, and many do not benefit. The complexities of managing chronic pain and all of the psychosocial factors associated with it (Drayer et al., 1999; Fishbain et al., 2000) appear to contribute to an inadequate global response to chronic pain. At the same time, the importance of addressing pain appears clearer than ever. There are now calls to radically reconsider the ways we diagnose, treat, and manage chronic pain, such as in the Institute of Medicine's (2011) report on "*Relieving Pain in America*" (Goldberg & McGee, 2011).

For the past 40 years or so psychological theories have provided credible accounts of chronic pain, accounts that naturally incorporate psychological processes as key factors. As applied to chronic pain, behavioural and cognitive-behavioural methods have significantly improved the management of chronic pain and contributed greatly to our overall ability to more effectively treat this condition (see Jensen, 2011; Jensen & Turk, 2014 for reviews).

3.2 The Early Years

Pain has probably always puzzled man to some degree, since at least the time when he or she was able to represent the experience as a thought in the mind, wonder about it, and speak about it. Prior to the mid-20th century, although there were early observations of pain that acknowledged its partially emotional and not solely physical quality, models of pain and pain research primarily focused on physiology. Early work by a psychologist, Henry Rutgers Marshall (as cited in Benjamin & Wallers, 1984), was an exception to the trend of pain research at that time. In his work, he highlighted the importance of

psychological states and the environment as contributory factors to the pain experience, and suggested that psychological and behavioural methods should be used in the treatment of pain.

The notion that psychological factors can play a part in the pain experience was not widely accepted or main-stream until relatively recent times. An early and popularly cited example supporting this notion arose in the mid-1940s, with Henry Knowles Beecher's field observations of soldiers' responses to pain during the Second World War (as cited in Melzack and Wall, 1965). Already mentioned in Chapter 2, Beecher's findings reflect an essential quality of the pain experience that is widely accepted (or ought to be) in approaches to chronic pain today.

During the early period of the 1940s to the mid-1960s, psychoanalytic theory appeared to be the dominant model applied for explaining pain due to supposed non-organic causes (Engel, 1959). These models considered past experiences, family dynamics and personality factors as important factors to explain otherwise unexplained pain (Adams et al., 1996). Empirical support for these models was limited however, based on studies of low quality and inconsistent results.

In the 1950s, one of the early pioneers, John Bonica (1953), became the first to formally set up a multidisciplinary pain clinic to treat chronic pain. However, despite demonstrating the benefits for this form of treatment, Bonica (1953) did not receive much support for his work until later. With the introduction of the Gate Control Theory (Melzack & Wall, 1965), there was then a plausible basis for multidisciplinary work and a key impetus for the role of psychological treatments for pain.

3.3 The Operant Approach

Building on the work of Skinner (1953) and others, Fordyce (1976) characterised chronic pain as a behavioural problem, and was the first to formally propose the application of operant behavioural methods to the treatment of chronic pain. This approach to chronic pain offered a radical and fundamental change in how pain was viewed. At that time, the perception was that pain was either a result of underlying tissue pathology or the manifestation of some form of personality disturbance. The operant approach as applied to chronic pain instead focused on the principle that manipulation of environmental factors could shape, alter, weaken or strengthen patterns of overt behaviour related to pain (Fordyce, 1976). The operant approach was, and in many ways remains the mainstay behaviour therapy (BT) approach for treatment of chronic pain.

Operant Theory as Applied to Chronic Pain

According to operant theory, a key dimension of human behaviour is that it is modifiable by the consequences it meets (Fordyce, 1976). In this way, behaviour patterns are selected, strengthened, discriminated and generalised. In short, certain behaviours are made more likely to occur in the future when they meet reinforcing events while other behaviours are made less likely to occur in the future when they meet unfavourable or punishing events. Within the operant approach, pain is reconceptualised within a focus on behaviour and influences on that behaviour.

Observations of behaviours like limping or rubbing, facial expressions like grimacing or frowning, and so on, that communicate pain to others are classified as “pain behaviours” (Fordyce, 1976). Fordyce (1976) asserted that pain behaviours are generally not useful in the context of chronic pain and can

often become maladaptive, maintain pain and contribute to disability especially when reinforced with responses from others, such as attention, support, or care. The primary goal of operant methods, are to firstly identify the environmental factors that precede, accompany and follow the expression of pain behaviours and secondly to treat the experience of disability and expressions of suffering through changing the relationships between pain behaviours and the events or contingencies that reinforce them (Roberts, 1981). In addition to clinicians delivering treatment, significant others can also be trained to respond more usefully to patients' behaviours (Flor & Turk, 2011; Fordyce, 1976). A decrease in pain behaviours marks a successful treatment outcome from the operant approach (Fordyce et al., 1985).

Empirical Support for the Operant Approach

A number of studies provide empirical support for the operant model as applied to chronic pain (Cairns et al., 1976; Fordyce, 1973; Roberts & Reinhardt, 1980). Early evidence supporting the efficacy of the operant approach for chronic pain included results from laboratory studies showing that pain behaviours may be decreased if they are ignored and 'well-behaviours' are reinforced (Fordyce et al., 1973).

Outcome studies that incorporate operant principles have shown an increase in patients' uptime (Cairns & Pasino, 1977), increased activity levels and improved health status (Roberts & Reinhardt, 1980), with reports of reduced pain, disability and psychological dysfunction (Henschke et al., 2010). Operant treatment programs for chronic pain have also been effective in decreasing levels of pain and pain behaviours, while increasing levels of functioning (Fordyce et al., 1981, 1985; Turner et al., 1990). Fordyce and colleagues (1985) concluded that multidisciplinary pain treatment programs that

applied operant approaches can reduce pain ratings, pain behaviours, including verbal expressions of pain, and medication usage. Extended reviews by Linton (1986) and Keefe and colleagues (1992) also found operant approaches to be effective in increasing activity levels and reducing medication consumption, but less effective in improving subjective reports of pain levels.

More recently, it was demonstrated through a systematic review and meta-analysis of treatment trials applied to chronic pain, that BT, the approach most associated with the operant approach lacked strong evidence as an effective treatment (Williams et al., 2012). Compared with an active control, only a small improvement in mood immediately following treatment was found. In comparison with inactive control conditions, BT demonstrated small effects on catastrophising and pain immediately post-treatment but with no other benefits. Trials measuring the efficacy of BT included mostly small samples and were weak in methodology and design, with few trials comparing BT with an active control. Insufficient follow-up data also prevented firm conclusions about the longer-term effects of BT as a treatment for chronic pain (Eccleston et al., 2009); Williams et al., 2012).

Criticisms of the Operant Approach

One main criticism of the operant approach is that it did not take into consideration the social setting and the presumed needs of the individual (Keefe & Gil, 1986). It is unclear whether gains made through participation on operant pain management programs can be maintained when patients are faced with other stressors or contingencies within their environment.

A majority of outcomes studies supporting the efficacy of operant treatments were weaker in design quality being mostly cohort studies and not RCTs, making it difficult to make firm conclusions regarding the findings

presented (Williams et al., 2012). Of course these studies were mostly done during an earlier time when less stringent methods were used than are used today.

A third criticism, whether justified or not, was that operant methods did not treat pain (Fordyce et al., 1985). Although patients may experience a reduction in pain after treatment, the primary goal of the operant approach is to reduce disability associated with pain and not to reduce pain directly (Fordyce et al., 1985). Although we do know that despite high reported levels of pain, chronic pain patients can show relatively low levels of disability and distress.

It cannot be denied that this radical proposal by Fordyce (1976) contributed a great deal in how we see chronic pain today. The development of the operant approach appears to have initiated a period of heightened attention to the psychological treatment of chronic pain. This development eventually paved the way for an increased acceptance of psychological pain interventions, and provided psychologists with an important role in treating chronic pain. With the adoption of the operant approach, emphasis was also placed on taking into account the psychosocial context of the patient's experience and from that, gradually over time, the role of psychology in chronic pain was slowly established (Jensen & Turk, 2014).

3.4 Cognitive-Behavioural Models

A cognitive evolution in clinical psychology in the 1970s and 1980s saw the expansion of early behavioural models of psychological treatment shift toward a greater focus on cognitions such as that of beliefs and attributions (Jensen & Turk, 2014). A combination of BT and cognitive therapy, now well known as cognitive-behavioural therapy (CBT) emerged mostly in the 1970's (Turk et al., 1983). The CBT model, intended to include a wider perspective

than the separate models underlying cognitive and behavioural techniques alone, grew in popularity in the 1980s. It is today the dominant psychological approach to chronic pain (Flor & Turk, 2011). More recently, the tradition of CBT described here is referred to as the “second wave” of psychological treatments for chronic pain. The operant approach was considered to be part of the first wave of such treatments.

CBT works on a few underlying assumptions, which are: (a) cognitions represent important potential influences on mood and behaviour (b) an interplay of affect, cognition and behaviour influence how one interprets and understands any given situation (c) cognitions can be assessed, evaluated and modified and (d) a change in cognitions and related attentional processes can alter maladaptive psychological states (Jensen & Turk, 2014).

CBT Methods as Applied to Chronic Pain

Psychologists have started applying CBT models to the treatment of chronic pain now for more than 30 years (Turk et al., 1983). According to a cognitive-behavioural model of chronic pain, it was believed that the pain experience is perpetuated by patients’ unhelpful beliefs about pain. As such, modifying these unhelpful beliefs can help patients develop more control over their pain, and was expected to result in the modification of the maladaptive behaviour and the pain experience (Turk, 2003).

The main goal of CBT treatment is to increase patients’ sense of self-control, to develop skills for the management of physical, emotional and mental stress that comes with pain, and instil a sense of hope (Turk et al., 1983). Patients are taught that increased stress responses, experience of negative mood and other emotions including emotional stress brought about by negative responses from family and friends can all contribute and aggravate the chronic

pain condition (Turk & Winter, 2006). They are also taught to manage fear and avoidance. Relaxation techniques including guided imagery, communication skills, problem solving skills, and relapse prevention, amongst other skills are commonly trained within current forms of CBT (Keefe et al., 1997). Through learning new skills or coping strategies, patients gain the ability to manage their symptoms, and their physical limitations, increase their daily activities, and to return to work in a graded fashion (Thieme et al., 2003, Turk, 2003). Patients are encouraged to actively participate in treatment, with 'homework assignments' built in as a major component of therapy (Turk, 2003). Difficulties arising as a result of these home-based practices are discussed in subsequent sessions, where patients also learn to manage treatment relapses and setbacks (Turk et al., 2008). In this way, patients learn to develop adaptive responses and adjust their behaviour appropriately to future difficulties.

Efficacy of CBT

Many published trials on the efficacy of CBT for chronic pain are currently available. The vast majority of these studies support the effectiveness of CBT in reducing pain, disability, emotional distress, medication use, healthcare utilisation and increasing activity levels as well as work-related and social activities (Flor et al., 1992; Hoffman et al., 2007; Williams et al., 2012). Generally, CBT type interventions are widely regarded as evidence-based for chronic pain in relation to both physical and emotional outcome domains, but this conclusion requires some qualification (McCracken & Turk, 2002).

Systematic Reviews and Meta-Analyses. Empirical support for CBT treatments for various chronic pain disorders has been shown in numerous reviews and meta-analyses (Eccleston et al., 2009; Morley et al., 1999; Williams et al., 2012). An early systematic review and meta-analysis comparing CBT

treatment with waiting list (WL) control demonstrated a medium effect size for pain, coping, mood and social role performance, supporting CBT treatment (Morley et al., 1999). When compared to alternative treatments, patients who underwent CBT treatment also showed an improvement in pain behaviours, pain experience and coping, demonstrating that CBT is an effective psychological treatment for chronic pain (Morley et al., 1999). Both individual and group based treatments utilising CBT-based methods have also shown an equal measure of cost-effectiveness (Gatchel & Okifuji, 2006; Turk, 2002).

As the number of studies conducted has increased over time, a number of more careful meta-analyses have been conducted and published (Eccleston et al., 2009; Hoffman, 2007; Williams et al., 2012). All of these meta-analyses focused on what is being referred to here as traditional CBT. Eccleston and colleagues (2009) found CBT to have small positive effects for pain, disability and mood. In a more recent review, Williams and colleagues (2012) found statistically significant but small effects for pain and disability with moderate effects found for mood and catastrophising in comparison to WL or treatment as usual (TAU). Compared to active control conditions, statistically significant effects were only shown for disability and catastrophising at post-treatment. Only a significant effect of disability was maintained at 6-12 month follow-up. The authors suggest that instead of more RCTs, further work on CBT should investigate whether a select group of patients was more responsive to specific components of CBT (Williams et al., 2012).

Systematic reviews have also been conducted on CBT for specific types of chronic pain, in particular, chronic low back pain. CBT was found to be a more effective for non-specific low back pain compared to BT (van Tulder et al., 2002) and more effective than WL or TAU (Hoffman et al., 2007; Sveinsdottir et

al., 2012). However, no significant differences between CBT and TAU were found for long term effects on pain or functional status (Henschke et al., 2010). Differing methods appear to contribute to inconsistencies across these reviews. Certainly results from CBT are positive and fall within particular outcome domains and comparison types.

Studies in populations suffering fibromyalgia have also considered the efficacy of CBT. Earlier meta-analyses assessing the efficacy of psychological interventions including CBT for fibromyalgia produced mixed results. Some studies provide evidence in support of the efficacy of CBT (Goldenberg et al., 2004; Thieme & Gracely, 2009) while others show no strong evidence that CBT was superior to WL or TAU (Bennett & Nelson, 2006; Sim & Adams, 2002). Differing patient samples, utilisation of different techniques within CBT, and differing interpretations of data likely contributed to the mixed findings (Glombiewski et al., 2010).

In general, CBT-based treatments have shown to be more effective than WL and TAU in a majority of studies. Studies assessing CBT for chronic pain has shown CBT to be effective in decreasing pain intensity and pain interference, and increasing mood and activity levels (Morley and Williams, 2006). However, an important missing element in the research evidence is that the therapeutic processes underlying treatment effects remain unclear at present (Jensen & Turk, 2014; Morley, 2004).

Criticisms of Traditional CBT

Despite the empirical support surrounding CBT treatments for chronic pain, gaps exist particularly in the conceptual models underlying this work, in the magnitude of benefits, and in our knowledge of treatment mechanisms (Williams et al., 2012). It would seem that improvements in outcome variables

measured are not uniform across patients. Some patients show improvement in all variables, some patients show improvement in selected variable and others show no improvement at all.

There is much variability in the content, treatment delivery formats and intensity of CBT treatments for chronic pain, some earning more empirical support than others. There does not appear to be a single “gold standard” treatment manual for individual nor group-based treatment, with many treatment manuals utilised in studies often not published or made publicly available (Ehde et al., 2014). There is also a lack of research specifically comparing differing treatment content, formats, treatment intensity and efficacy of booster sessions after initial treatment (Ehde et al., 2014). Recommendations for optimal mode of treatment delivery, duration and frequency of treatment sessions for chronic pain in general, or for specific subgroups of patients are also lacking (Ehde et al., 2014). As such, comparisons across studies are often difficult and sometimes not feasible.

Reviews of CBT interventions for chronic pain have demonstrated mostly small effect sizes or medium ones at best, with patients also shown to receive inconsistent benefits from traditional CBT interventions (Eccleston et al., 2009; Vlaeyen & Morley, 2005; Williams et al., 2012). One of the reasons might be, as mentioned, that despite research efforts, relatively little is known about the specific mechanisms that lead to chronic pain and pain disability, with little research published on the mechanisms of change in CBT, and little consistency in the studies that do appear (Ehde et al., 2014; Turner et al., 2007). There is a need for an increased effort in the development of systematic strategies to increase the therapeutic impact of CBT on chronic pain. It is suggested that greater focus on therapeutic processes based in theory could do this.

Like many other types of psychological intervention, CBT relies on therapists to deliver treatment. Delivery of treatment, however, is fluid and dependent on many factors including the experiences that the therapist brings into treatment. There is relatively little research on therapist effects in the delivery of CBT for chronic pain (Ehde et al., 2014). Therapist effects however do exist, linked to factors such as therapist competence, adherence to the CBT model, and the therapeutic alliance between the patient and the therapist (Wampold, 2001). Such effects are potentially important and warrant further study, as do effects of differing therapist training strategies.

There are still gaps in our understanding about which particular processes within CBT and which treatment components correspond to which changes in outcome (Morley, 2004). Hence, it seems we can only make imprecise conclusions about the influence of such processes on a broad range of outcomes rather than specific ones. More precise models of change need to be developed allowing a direct link of specific cognitive and behavioural processes to specific outcomes.

Additional challenges for CBT in the years ahead not only include the assurance of the 'integrity and quality' of treatment delivery but also the development of outcome measures that include clear criteria to index clinically meaningful change from treatment in differing domains of functioning (Morley, 2011).

3.5 Fear-avoidance Model

Within the developments of CBT treatment for chronic pain, a new model, the Fear-avoidance model (FA) emerged (Vlaeyen & Linton, 2000). It was based in part on an initial proposal of a basic conditioning model of pain-related fear avoidance by Linton and colleagues (1984). In many ways, the FA model is

simply a more focused version of a CBT model and has contributed to understanding and addressing the significance of avoidance behaviour in the adjustment of chronic pain. The FA model is briefly reviewed here.

Early models of fear-avoidance (Lethem et al., 1983; Philips, 1987; Waddell et al., 1993) clearly suggest that avoidance behaviour could occur separate from the sensory component of pain. Specifically, it was proposed that pain avoidance was a result of beliefs, expectations and interpretations surrounding the perception of pain and not directly related to pain severity. Adding to these earlier models, at the core of the FA model is the inclusion of two alternative behavioural responses of confronting pain and avoiding pain, each leading on to its own series of results. Figure 3.1 depicts the FA model.

Figure 3.1: Fear-Avoidance Model



From "Fear-avoidance and its consequences in chronic musculoskeletal pain: a state of the art." By J.W.S. Vlaeyen and S.J. Linton, 2000, Pain, 85, p. 317-332. Copyright by Wolters Kluwer Publishing Inc. Used with permission.

When pain is positively appraised and perceived not to cause harm, continued engagement in activities is likely to occur. However, as depicted in the FA model, when catastrophic appraisals are made, fear emerges.

Continued avoidant behaviours can ensue, leading to reduced activity levels and other physical and psychological consequences that maintain a high level of pain and disability. These unhealthy learned behaviours can become complexly reinforced and difficult to treat over time. They can become discouraging and reduce confidence to manage pain, rendering this fear of pain more incapacitating than pain itself (Vlaeyen & Crombez., 1999; Vlaeyen & Linton, 2000).

Support for the FA model comes from cross-sectional studies with chronic pain patients (Keefe et al., 2004; Leeuw et al., 2007), longitudinal studies with low back pain patients (Picavet et al., 2002) as well as results from structural equation modelling (SEM) in cross-sectional studies examining the relationship among the variables of the FA model (Cook et al., 2006; Wideman et al., 2009). The fear of movement and (re)injury appear to be better predictors of functional limitations than pain severity and pain duration itself, with symptoms of pain exacerbated by a fear of pain and activity avoidance (Crombez et al., 1999; Gheldof et al., 2010; Turk et al., 2004; Vlaeyen et al., 1995). A systematic review of fear-avoidance beliefs in patients with chronic low back pain of less than six months, demonstrated that fear-avoidance beliefs are related to poor treatment outcomes (Wertli et al., 2014). Findings suggest that early interventions to reduce fear-avoidance beliefs may reduce the risk of chronicity and prolonged recovery. Collectively, findings from studies surrounding fear avoidance and pain contribute to our understanding of the significant role of pain-related fear in the development of disability.

A recent review on the progress of the FA model since its inception in 2000, led to two main conclusions (Vlaeyen & Linton, 2012). Firstly, it was concluded that limited progress has been made with regards to the assessment

of behavioural and physiological features described in the FA model. Although there is progress in the development of self-report measures (George et al., 2009; Roelofs et al., 2011) and the use of automated devices to more accurately monitor activity levels (Verbunt et al., 2009), an objective measure of avoidant behaviour for fear eliciting activities and safety seeking behaviours still remain a challenge (Vlaeyen & Linton, 2012). Further research is needed to inform the development of more specific assessment techniques that could increase the predictive validity of the FA model as it relates to disability for chronic pain (Vlaeyen & Linton, 2012).

In terms of specific treatment development, the FA model has led to the adaption of graded in-vivo exposure, originally a treatment for anxiety disorders, to the treatment of chronic pain and related disability (Bailey et al., 2010; Hollander et al., 2010). Results supporting the treatment efficacy of graded in-vivo exposure for chronic pain have however been modest (Vlaeyen & Linton, 2012).

Critique of the Fear-Avoidance Model

Despite its clear successes and prominence, the FA model has also been criticised. Firstly, the scope of the model is too narrow in assuming that all avoidance is fear-related, and that all patients who show pain-related fear will experience a vicious cycle of enduring pain (Wideman et al., 2013). These assumptions do not take into account that people suffering from this condition can experience differing number and duration of pain episodes, altered levels of pain intensity and disability. The FA model's predominant emphasis on catastrophising and fear negates other pathways to disability, pathways that emerge from other experiences, such as depression, embarrassment, or confusion (Pincus et al., 2010). Other limitations are that, the FA model does

not account for the fact that pain-related fear and avoidance functions within a complex interplay of multiple and often competing personal goals, nor does it adequately address the process of therapeutic change (Crombez et al., 2012). In general, there appear to be many other potential psychological factors in relation to chronic pain that simply do not appear within this model, and hence it may only account for the problems faced by a subgroup of chronic pain patients and lend itself to a focus on a limited set of potential treatment methods (Turk & Wilson, 2010).

Despite criticisms of the FA model, it has highlighted interest in avoidance behaviour in the adjustment of chronic pain. It has also provided a theoretical framework by which to understand how negative appraisals, wrongful expectancies and fear can influence the experience and expression of pain. In many ways it has been a successful model for looking at prevention of disability (Linton, 1998) and treatment development (Bailey et al., 2010; De Jong et al., 2005; Turk & Wilson, 2010; Vlaeyen et al., 2001).

3.6 Delivery of CBT through Other Modalities

Interdisciplinary Group Programs

To sufficiently address the biopsychosocial model of pain, the IASP taskforce suggested that expertise from a mix variety of healthcare professionals with different training backgrounds should be offered at interdisciplinary pain centres (Task force on guidelines for desirable characteristics for pain treatment facilities, 1990).

The delivery of a CBT model of care through interdisciplinary group pain management programs, including physiotherapies, nurses, physicians, and others, as well as psychologists, has been the treatment of choice in these centres (Gatchel et al., 2014). Interdisciplinary programs are usually short term,

skill oriented interventions which include medical and physical components together with CBT methods in treatment, and designed to maximise the benefits provided by all components of the program (Gatchel et al., 2014).

Efficacy of Interdisciplinary Programs. Interdisciplinary treatments including CBT have demonstrated success in reducing pain intensity, disability, improving function and return to work (Cutler et al., 1994). An early review (Flor et al., 1992) demonstrated that interdisciplinary treatments for chronic pain were superior to single discipline treatments, WL and no treatment conditions, with effects maintained over time. Interdisciplinary treatment was found to improve pain severity, interference, mood, healthcare utilisation and return to work. However, as study descriptions and quality of designs were sometimes poor, results must be interpreted with caution.

Clinical guidelines for the treatment of low back pain have recommended interdisciplinary treatment for chronic low back pain (Chou et al., 2009b). Systematic reviews conducted on low back pain have found strong support for interdisciplinary pain treatment in areas of improved pain, disability, function and healthcare utilisation (Gatchel & Bruga, 2005; van Tulder et al., 2002) including long-term effects on pain severity, interference and disability also found at one year follow-up (Oslund et al., 2009).

Despite evidence supporting the efficacy of interdisciplinary treatment (Gatchel & Okifuji, 2006), the number of interdisciplinary pain clinics has reduced over the years (Gatchel et al., 2014). This is in part due to inadequate staff training, inconsistencies in how interdisciplinary pain programs are run, lack of clearly defined guidelines, and perhaps poor communication, and inadequate program advocacy (Gatchel et al., 2014; Thunberg & Hallberg, 2002).

Telephone-delivered CBT

There is some evidence that telephone-delivered CBT (TCBT) for chronic pain may offer an alternative to face-to-face treatments especially where treatment accessibility is a barrier (Bee et al., 2010). TCBT is probably cost-effective compared to TAU (McBeth et al., 2012). However, studies in this area and including a multidisciplinary approach are generally few and of low quality (Karjalainen et al., 2000).

Technologically-based Interventions

In recent years, practitioners of CBT have devised innovative and alternative ways to deliver treatment, moving away from exclusive reliance on the traditional face-to-face treatment delivery. These developments aim in part to create more cost-effective treatments and to increase accessibility to psychological treatments for chronic pain.

Internet-based Interventions. Modern day technological advances include development of the internet and mobile applications (apps). Delivery methods for psychological interventions have started to ride on this wave of technology development to address issues of accessibility, affordability and improving clinical outcomes (Naylor et al., 2010). A range of CBT-based treatments for pain have utilised technological assistance, for example interactive voice response technology (Lieberman & Naylor, 2012), video conferencing (Gardner-Nix et al., 2008) and online programs (Carpenter et al., 2012; Eccleston et al., 2014; Ruhlman et al., 2012) to name a few. In addition to cost and access issues, evolving technologies may be able to support maintenance of long-term treatment gains that conventional face-to-face treatment has not been able to consistently achieve. Although, this is not yet firmly established.

Trials involving internet-delivered CBT (Buhrman et al., 2004; Buhrman et al., 2013; Carpenter et al., 2012; Dear et al., 2013; Williams et al., 2010) have shown to be relatively effective in both physical and mental health domains (Andersson et al., 2008; Cuijpers et al., 2008, Dear et al., 2013), with studies suggesting that internet-delivered CBT is probably cost-effective as compared with no treatment or to conventional CBT (Hedman et al., 2012).

Systematic reviews examining the efficacy of internet-based interventions for chronic pain find evidence for small effect sizes in average pain ratings and disability across studies (Bender et al., 2011; Eccleston et al., 2014; Macea et al., 2010). Improvements in depression and anxiety were not consistent (Bender et al., 2011). In general, compared to traditional face-to-face CBT, it would seem that internet-delivered trials achieve similar effects (Eccleston et al., 2014; Hedman et al., 2012). Although internet-based treatments seem promising for the treatment of pain, there is much variability in treatment content, treatment duration and outcome measures (Jensen & Turk, 2014) with varying attrition rates of 0-58.9% found across studies (Bender et al., 2011; Eccleston et al., 2014; Macea et al., 2010). It is also unclear which group of patients might benefit more from such an intervention.

Factors such as level of therapist input, the program's ability to provide real time feedback, ability to effectively address patients' questions and concerns, ways to motivate patients, ways to achieve low attrition rates and maintain treatment fidelity are important design considerations for internet-based interventions (Eccleston et al., 2014). Given the relatively lower cost of internet-based interventions in the long-run compared to face-to-face treatment, and their ability to address some barriers to treatment access for chronic pain, it seems worthwhile to continue to invest in and develop this mode of treatment

delivery (Eccleston et al., 2014). Further research to determine characteristics and types of patients who might benefit from such interventions is clearly warranted.

Smartphone-delivered Interventions. With technological advancement, came the development of smartphones. Smartphone technology which combines mobile phone and computer technology has the advantage of allowing the user easy access to the internet in many settings (Rosser & Eccleston, 2011). With smartphone technology, treatment of pain need no longer be confined to face-to-face clinic-based care that may not be as accessible, and carry long wait times. Smartphone apps may help people with chronic pain self-monitor their pain and functioning, and engage in real-time pain management strategies (Lalloo et al., 2015). However, results from recent reviews on pain apps have been disappointing. Overall, it was reported that pain apps lack theoretical and clinical rationale in their development, include few actual behaviour change strategies, lack integrated features that address the multidimensional nature of pain, and rarely include health professionals in their development and evaluation (Lalloo et al., 2015; Rosser & Eccleston, 2011).

To date, there are particularly limited data from studies of smartphones used to deliver CBT-based treatment for pain and no RCTs that have evaluated the effectiveness of pain apps on health outcomes (Ekeland et al., 2010; Rosser et al., 2009). As technological innovations progress, growth in smartphone apps and usage is likely to increase in tandem. More rigorous studies using smartphone platforms are needed to test the usability and effectiveness of smartphones in delivering psychologically-based pain interventions within theoretical frameworks.

CBT-based Treatments Delivered by other Health Professionals

Increasingly, as part of a need to make treatments more cost-effective and accessible, health professionals who are not trained psychologists have been trained to deliver CBT-based treatments. This move is in part to address the lack of psychologists in clinical practice trained to deliver treatment for chronic pain. One relatively large funded study (N=701) that evaluated a cognitive behavioural treatment delivered by a range of health professionals working in primary care, most of whom were not psychologists, demonstrated some success (Lamb et al., 2010). Results showed that the intervention delivered by nurses, and physical and occupational therapists, in addition to psychologists, significantly reduced pain, disability, and improved health related quality of life for patients suffering from sub-acute and chronic low back pain. These effects were maintained at 12 months follow-up with the effects on disability maintained beyond 12 months and CBT demonstrated to be superior to the control condition of best practice advice (Lamb et al., 2012). Best practice advice encouraged improvement in low back pain but to a limited degree, with little impact on disability.

3.7 Other Treatment Approaches

There are other specific treatments that sometimes sit alone or outside of CBT. Other treatment approaches such as relaxation, biofeedback, hypnosis and motivational interviewing have been adopted in the treatment of chronic pain (Jensen, 2011; Jensen & Turk, 2014). These approaches play a smaller role in the wider developments of psychological treatment approaches to chronic pain. It is beyond the scope of this chapter to provide a review on all of these here.

3.8 Conclusion

The role of psychology and its importance in the management of chronic pain is now virtually established. Psychological models have evolved in the past 50 years but have provided a plausible and in some ways, easy to understand approach relying more or less on models of beliefs, coping skills and self-management. Psychological theories and the research emerging from them have established that pain is a complex phenomenon that requires a multifaceted approach in treatment. Research evidence, particularly from systematic reviews and meta-analyses, support the conclusion that CBT-based treatments for chronic pain are more effective than inactive comparison conditions. However, most treatment outcomes seem to include small effects sizes or are moderate at best (Eccleston et al., 2009; Williams et al., 2012), with none of these treatments able to produce large effects for most people, in most outcome domains, for the long term. A continuing question for current research regards processes of change, what are the key ones, what methods create these changes, and how these methods can be even further optimised. An additional question regards optimal modes of delivery and the role of information and communication technology.

Can 'third wave' psychological treatments provide answers to these ongoing questions? The theoretical model, practical approaches and empirical support for treatment efficacy of two more commonly used third wave treatments for chronic pain (a) Acceptance and Commitment Therapy (ACT) and (b) Mindfulness-based interventions are discussed in the next chapter.

Chapter 4: Acceptance and Commitment Therapy (ACT) and Mindfulness-based Therapies for Chronic Pain

4.1 Chapter Overview

Following the descriptions of operant and cognitive behavioural treatment developments in the previous chapter, this chapter focuses on introducing what is sometimes called the “third wave” of these developments, and sometimes referred to as “Contextual Cognitive Behavioural Therapy” (CCBT). This chapter provides mainly a review on Acceptance and Commitment Therapy (ACT). This includes a brief philosophical outline of ACT, an overview of Relational Frame Theory (RFT), a description of psychological flexibility (PF), a summary of the evidence for ACT treatments for chronic pain, and current challenges. A brief review of mindfulness-based therapies as applied to chronic pain is also presented.

ACT (Hayes et al., 1999) and mindfulness-based therapies (Kabat-Zinn, 1990) are currently the most recognised variants of CCBT. Those who work within these approaches point out that they include not just a shift in methods, but a shift in philosophy and theory from the second ‘wave’ of psychological treatments (McCracken & Vowles, 2014). More widely, however, the distinctions between these current developments and the mainstream of CBT are not universally agreed (Hofmann & Asmundson, 2008). Those interested in developing ACT do not intend it to compete with CBT, as such. ACT is a form of CBT after all. Both ACT and mainstream CBT have their distinct elements and also considerable overlap with the larger family of CBT-based approaches. Like any form of CBT, ACT aims for cognitive and behavioural change (Hayes et al., 1999). Again, the level at which these different approaches within CBT differ is primarily in philosophy, principles, and processes, as this chapter will show.

4.2 A Brief Philosophical Outline of ACT

To appreciate ACT as a whole and what is unique about it requires a basic understanding of some of the key philosophical assumptions underlying ACT. Unlike some therapeutic approaches, ACT is guided carefully by these philosophical assumptions (Hayes et al., 1999). ACT is defined primarily by its adherence to the philosophy of functional contextualism. This is the philosophy that defines the dependent variables, model of causality, and epistemological assumptions to follow in establishing a complete account of behaviour. “Behaviour” here is the action of the whole organism in a historical and situational context, examined holistically and not in isolation (Hayes et al., 1988, 1993). Functional contextualism is interested not only in allowing one to explain and predict events but also to influence and make changes to psychological situations identified as maladaptive (Hayes et al., 1993). Two main assumptions

of functional contextualism, the subject matter, “the act in context,” and the basis for knowledge, the “pragmatic truth criterion,” (Hayes et al., 1999) are further described here.

The Act in Context

A primary principle in a contextual view of behaviour is that behaviour is defined by its functions or context (Hayes, 1987). As a specific example, an individual feeling pain may have the thought that “I must see the doctor for my pain”. If this thought occurs during an important company meeting, he or she may continue to sit through and participate in the meeting as usual, and depending on his or her past experiences in similar situations, may not act on this thought as if it were true and needed to be followed. This same individual may behave quite differently if the same thought occurred in another situation, for example experiencing an unfamiliar bodily sensation whilst engaging in a new physical activity. The historical consequence of behaviour in these different contexts is the key organising notion.

As applied in therapy, all verbal expressions of inner experiences such as thoughts, feelings, bodily sensations and actions related to them are analysed according to how they function for the individual (Hayes et al., 2012). By clarifying and assessing the function of the individual’s responses, the ACT therapist is able identify manipulable influences on the behaviour or interest. When manipulable influences within these functions are then altered, they are then able to create behaviour change and reduce behaviour patterns that do not constitute healthy functioning (Twohig, 2012).

Pragmatic Truth Criterion

The truth criterion of functional contextualism is “what is true is what works” (Hayes et al., 1999). Truth is defined by whether a particular activity or

set of activities aid in the achievement of a specified goal (Hayes et al., 1993). Goals are the means by which a pragmatic truth criterion can be applied to events. Personal goals and values need to be specified in order to assess “truth” for the particular situation at hand. Very often, it is found that the “truth” a person believes is a matter of literal consistency, for example, a person may feel that they must do what their thoughts say, even though it does not serve their goals to do it (McCracken, 2005). Individuals thus get caught into taking their thoughts literally and suffer from the unworkable behaviour patterns that occur as a result (Hayes et al., 1999).

In practice, the pragmatic truth criterion is applied through promoting better awareness from direct experiences of what works and what does not, whether these are consistent with what thoughts say or not (Hayes et al., 1999). Explicit verbally stated goals thus provide a useful guide in clinical intervention (Hayes et al., 1993). It is important that in treatment, individuals are guided to properly define “process” goals and “outcome” goals - this is an important distinction in ACT (Yang & McCracken, 2014). Individuals with pain share a common goal to reduce pain. Often, if asked what would happen if this was achieved, a usual response would be, “if I did not have pain I would be able to go back to work”. Reducing pain in this case can be considered to be a process goal, while the outcome goal is for the individual to return to work. Going back to work is an end goal while reducing pain is a means to an end. Within ACT, individuals are helped to reaffirm their outcome goals, if they remain personally important, and, when needed, consider alternative process goals, such as openness to pain rather than reduction of pain.

ACT seeks to achieve balance in behavioural influence between inner experiences of what a person feels and thinks with what is directly experientially

present in the environment. This is the basis within treatment for preferring action goals, such as “speak to my employer,” rather than feeling-related goals, such as “feel less pain.”

4.3 Relational Frame Theory and Rule-governed Behaviour

Parallel to the development of ACT and consistent with the philosophy of functional contextualism are relational frame theory (RFT) (Hayes et al., 2001) and rule-governed behaviour (Hayes, 1989). Both these approaches, emerging from behaviour analysis, provide an account of cognition that has in some ways informed ACT. Details of their implication to human behaviour are fully described elsewhere (see Hayes et al., 2001; Torneke, 2010). Only a brief overview of RFT and rule-governed behaviour is provided here.

RFT provides an explanation of how verbal processes or stimuli come to acquire influences over behaviour (Hayes et al., 2011). At the core of RFT is the notion that much of human suffering is due to our ability to use language. Here language and the history and context in which it is learned can turn any object of thought into a source of pain (Hayes et al., 2011). Within RFT a new and unconventional definition of “verbal behaviour” is offered and forms a key concept. According to RFT, verbal behaviour includes acts of framing stimuli or events in relation to other events, in ways that do not depend on the formal properties of the events, and to responding or acting on stimuli based on the resulting relations (Torneke, 2010). These acts of relating are in turn governed by contextual cues.

A simple illustrative example of verbal behaviour is “rule-governed behaviour”. Rule-governed behaviour includes behaviour learned from a history of instruction-based learning, or through other processes where the development of a behaviour pattern is based on verbal learning (Skinner, 1974).

The behaviour of following a rule emerges from a history of verbal instructions either self-generated, informed by another person, or through other forms of verbal knowledge like books and media messages (McCracken, 2005). A rule that relates pain to physical damage and harm to the body, for example, is likely to lead to avoidance behaviours (McCracken, 2005). The difficulty with rule-governed behaviour is that it can be particularly insensitive to new learning opportunities and can persist even when it is unhealthy. Relational framing helps to clarify how this happens via the unique qualities of verbal stimuli and their capacity to transfer behaviour influencing effects with very broad applicability, and, again, requiring no formal similarity to the direct events to which they refer or relate.

Relational Framing

Relational framing is a behavioural capacity learned early in life through operant conditioning and it is characterised by three phenomena, namely: (a) mutual entailment, (b) combinatorial entailment, (c) transformation of stimulus functions based on established relations (Torneke, 2010). Mutual entailment refers to the relation that is learned in one direction being construed as applying in the opposite direction at the same time (Blackledge, 2003). For example, if it is learned that in a particular context A is related to B, then by mutual entailment, B is also related to A. So if pain has a relation to rest then rest has a relation to pain. Both the relations between A and B, in both directions, have precision.

Unlike mutual entailment which illustrates a simple reciprocal relationship between two stimuli, combinatorial entailment illustrates how complex networks of relations are built. Combinatorial entailment refers to the way that two or more mutually entailed stimulus relations that have had no relations with each

other, can combine to form new relations (Blackledge, 2003). For example, in a given context, if A relates in a specific way to B and B relates in a specific way to C, then a relation is entailed between A and C in that same context. Contextual cues make this so. In a given context, a person may learn that there is a relation between increased muscle tension and pain and between pain and a need for taking medication. An association then, between increased muscle tension with the need to take medication, even without an experience of pain will soon occur. Increased muscle tension now can become framed as part of the cause of taking medication.

Transformation of stimulus functions refers to the process when some of the functions in one stimulus change according to what stimulus it is related to, based on the derived relations between the two (Blackledge, 2003). Two contextual features: the relational context and the functional context help to regulate this process. The relational context controls how and when events are related while the functional context controls what functions will be transformed within a relational network (Hayes et al., 2012). For example, when a person exercises, exercise serves a function for general physical health; it influences physical functioning. If this same person continues to exercise for the purpose of competing in a race, exercise serves an additional function on behaviour; it influences the person's ability to compete at a target level. However, exercise can also serve a function of avoidance if related to other factors, for example for a person with chronic pain who experiences increased pain after exercising and whose goal is to achieve pain reduction.

Relational frames are learned and once relating occurs, it can be inhibited but not unlearned, leading to a possibility that the relational context can still derive unhelpful relations (Torneke, 2010). For example, there are

numerous ways an individual with pain can derive that engagement in physical activity triggers pain which in turn signals physical damage. Once this “impression” is derived it is likely to be ingrained as a potential influence that cannot be completely removed from a person’s learning history. Individuals however can learn to loosen the psychological impact of these associations through variations of cognitive defusion techniques for example (Luoma et al., 2007).

4.4 Psychological Flexibility

The theoretical model behind ACT is the psychological flexibility (PF) model. From an ACT perspective, PF, and its combination of cognitive and behavioural principles, is considered a model for psychological health and a model of creating behaviour change (Hayes et al., 2011).

Like other cognitive behavioural approaches, the PF model also recognises the influences that thoughts and feelings can have on behaviour. However these thoughts and feelings are viewed from a distinctly functional contextual perspective (McCracken & Morley, 2014). Specifically, PF is the ability to be in direct contact with the present, to be aware of thoughts and feelings; and to change a behaviour pattern or persist with one in the direction of chosen goals and values (Hayes et al., 2011). Processes of behaviour regulation within the context of internal experiences (including unwanted ones) rather than in the content of these experiences are emphasised. For example, according to the PF model, if anxiety is a barrier to action, a contextual shift or change is regarded to have happened when anxiety is no longer a barrier even without a change in the actual content of the anxiety experience itself.

Psychological Inflexibility

In contrast to PF is psychological inflexibility, a psychological model of suffering that restricts functioning and reduces wellbeing (Hayes et al., 1999). Processes behind psychological inflexibility are the opposite of PF. These processes include experiential avoidance, cognitive fusion, thoughts about the past or future rather than the present, an inability to perceive situations separate from thoughts and feelings, an inability to consistently engage in one's values, a failure in making and keeping commitments (McCracken & Morley, 2014). Together, these processes show how inflexible responses to pain, thoughts, beliefs and related emotions, as well as other psychological experiences, can restrict individual choices and limit healthy behaviour change (McCracken & Vowles, 2014).

For example, as applied to pain, experiential avoidance is the process whereby a person acts to limit, reduce, or otherwise control their contact with an experience that is unwanted in a way that limits reaching one's goals (Hayes et al., 1996). The experience of chronic pain includes pain as well as other bodily sensations and other unwanted experiences such as thoughts, memories and emotions. When these occur, experiential avoidance includes attempts at suppression, distraction, stopping or refusal to continue with activities that include these experiences. The pathological effects of these in chronic pain come in at least two forms. First, attempts like suppression often results in increased intensity, frequency, and duration of these unwanted experiences (Hayes et al., 1996). So, rather than eliminating pain, this type of avoidance perpetuates the experiences of pain and other related experiences in a vicious cycle of suffering and distress. The other effect is that stopping or refusing activities makes goals impossible, eventually compromises health and

wellbeing, and limits quality of life directly. This maintains chronic pain because pain remains the dominant influence on behaviour.

Cognitive fusion is a process whereby the individual does not distinguish the verbal content of thoughts from the events to which those thoughts refer (Hayes et al., 1999). For example, when an individual is fused with the thought (“Pain stops me from doing anything.”), he/she is experiencing that thought literally (“Pain” = “can’t do anything”). Cognitive fusion here allows the literal content of thinking to govern and direct an individual’s behaviour (“I can’t do anything because I have pain”), that which is typically characteristic of avoidance. With the individual’s choice of action being limited by these co-processes of experiential avoidance and fusion, ineffective behaviours and undesired outcomes perpetuating the pain experience are often maintained. Psychological inflexibility entraps the individual in a vicious cycle of thoughts, feelings, and avoidance, and perpetuates itself through a type of self-reinforcing process. And once again, this maintains chronic pain because through this type of process thoughts about pain will remain the dominant influence on behaviour.

PF and the Six Core ACT Processes

Conventionally, PF is addressed and enhanced through an emphasis on six core processes, which are ‘Acceptance’, ‘Cognitive Defusion’, ‘Present Moment Awareness’, ‘Self-as-Context’, ‘Values’, and ‘Committed Action’ (Hayes et al., 1999). These processes overlap and do not follow a particular order. Figure 4.1 depicts these processes within an ACT model.

Figure 4.1: An ACT Model

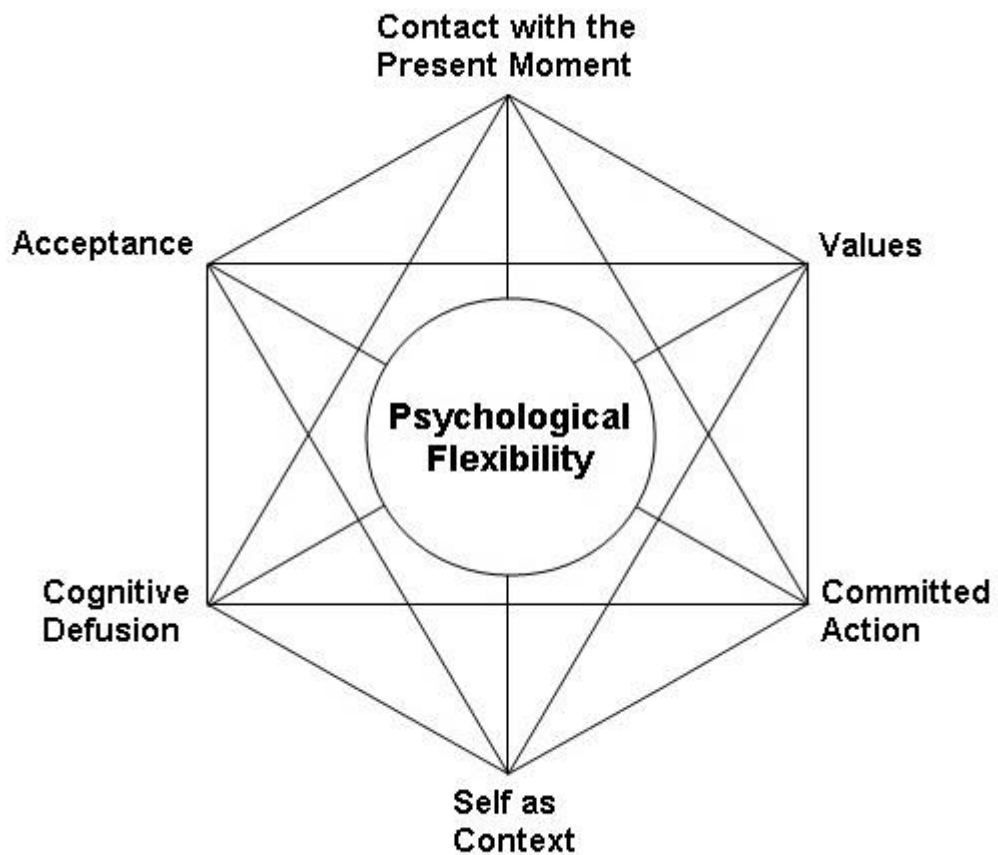

Copyright by Professor Steven Hayes, University of Reno, Nevada. Used by permission.

Acceptance involves an individual's willingness to have unwanted experiences while remaining engaged in pursuing their goals and values (Hayes et al., 1999). Acceptance includes a shift away from a predominant focus on changing the content or frequency of thoughts and feelings, a focus sometimes adopted within other psychological treatment approaches. Another way to say this is that acceptance encourages an opening up to feelings rather than struggling, avoiding or moving away from them.

Through these processes, situations that have historically coordinated avoidance, such as pain, or other related experiences, such as sadness, instead allow or coordinate other responses, such as goal-directed behaviour.

Former narrowness in behaviour patterns are broken down and made wider here, not allowing the experience of pain to become a barrier in pursuing positive daily life goals (McCracken et al., 2004).

Cognitive defusion is the process whereby the individual steps back from thoughts and see them for what they are, primarily separable from the events to which they relate (Hayes et al., 2006). In this process, the individual's responses to thoughts are modified and the unhelpful influences of thoughts on the individual's behaviour are lessened (Yang & McCracken, 2014).

Automatic thoughts such as "I can't stand this pain", "I am going to have a flare-up!", "Pain is killing me!" usually surface when an individual is in pain. In such situations, the individual or events often fuse with these thoughts. This is equal to believing the pain-related thoughts to be true, and subsequently choosing a course of action in agreement with these thoughts and related emotions. Thoughts such as "Pain has ruined my life, I can't do anything enjoyable anymore because of my pain" and "I don't want this pain, I must find a cure or a way to get rid of it before I can do anything useful" are likely to be cited by the individual as reasons not to engage in an activity. More than that, they are likely to be experienced as reality. Through the process of cognitive defusion, individuals can see that such thoughts and direct experienced events are not the same, and that thoughts about pain do not need to be causes of what one does.

Contact with the present moment is the process where the individual is aware of the event or situation as it happens, moment-to moment, and does not dwell in a focus on events or situations that have occurred in the past or will occur in the future (Yang & McCracken, 2014). Another way to say this is that it includes a flexible focus of attention and openness to experiences at a sensory

level as they occur in the environment in the present time (Twohig, 2012). In this process, the person is able to notice when he or she is not acting in relation to the present and can reconnect and shift attention back to the present moment if this shift benefits them (Yang & McCracken, 2014).

Through being in contact with the present moment, individuals with chronic pain can learn to adopt a non-defensive approach to pain. Thoughts, feelings and other sensations in relation to pain are regarded only as transient events that can have a limited influence on behaviour when one notices this transient quality. With more moment-to-moment awareness, psychological events related to chronic pain can pass with limited exerted influence and become more useful or important guides. Opportunities for adaptive behaviour in response to pain can then be seen and followed.

A sense of self-as-context, also considered as a kind of perspective taking, or a connection to self-as-observer, is another key process of PF. This is a particular experience of self or identity that differs from the conventional view. Ordinarily, our experience is that we are made up of thoughts, feelings, beliefs, and a kind of life story. Here we are the content of our psychological experiences. In PF however, a distinction is made between the self and this content (Hayes et al, 2012). In ACT, perspective taking can be trained so that a person is able to have an experience of self as 'having' content but not 'being' that content. This perspective allows us to follow inner conceptualisations of who we are (our life story), in particular situations when it serves our goals, and to not follow these in situations where it does not.

Through the process of the observer self, pain and other related experiences that may have been previously avoided are brought to the forefront of the individual. Pain-related thoughts and feelings that have influenced the

individual to avoid particular situations or activities are examined in a non-reactive and non-judgemental way (McCracken, 2005). As the individual learns to see these thoughts for what they are; just thoughts, rather than taking them as truths or reality, the negative influences of these thoughts on actions, in the presence of pain are reduced.

Values are essentially general life directions that function as guiding principles in one's life, and are individual to each person. Values are the global verbally constructed qualities a person chooses as important or desirable, that can be reflected in his or her behaviour (Hayes et al., 1999). Values can help to guide and motivate behaviour change. Clarifying values, regardless of the primary problem can be an important step for the individual to then take action towards a meaningful life (Hayes et al., 1999). Values are often contrasted with goals in that values are ongoing processes of action whereas goals represent set plans or targets or action that can be achieved (Yang & McCracken, 2014).

Individuals with chronic pain who feel stuck in their situation frequently use pain and related feelings to direct their choice of action or behaviour. Influences that encourage adaptive functioning in the presence of pain have little or no impact while maladaptive thought patterns telling the individuals what they can or cannot do when in pain are often followed (McCracken, 2005). Through the process of values clarification, individuals learn to follow their values rather than pain as guiding principles for action. Instead of avoiding pain, individuals choose to experience pain in order to engage in personally meaningful activities such as going on a holiday with their family, an outing with friends or a form of physical activity.

Committed action is a component of ACT that entails the development of behaviour patterns that are increasingly consistent with values and goals

(Hayes et al., 1999). This capacity for committed action is required for behaviour change to persist and eventually integrate into general patterns of behaviour. Committed action is inevitably an ongoing process of redirecting behaviour, explicitly including “off track” behaviour and catching and aligning it again with chosen purposes (Luoma et al., 2007). Committed action has the qualities of persistence and flexibility in that it includes behaviour that maintains a connection to values and goals over time, is at the same time dynamically attuned with the meeting of goals, and can change accordingly. The flexibility of committed action includes two types, as mentioned, it can go off track and return, and it can be abandoned if experience shows that it is not working (McCracken, 2013).

Even with other processes of PF in place, this does not always guarantee persistent healthy action. Individuals in treatment including those with chronic pain are taught to set goals along their valued directions and then build the capacity to act on these goals while at the same time engaging in the other ACT processes in the presence of pain or other unwanted experiences. Committed action is one of the least studied components of PF and yet data so far support its role in relation to wellbeing and daily functioning (McCracken, 2013; McCracken et al., 2015) in people with chronic pain.

From an ACT perspective, these six core processes in combination facilitate an increase in PF which can in turn contribute to better health and functioning.

4.5 Implementing ACT in Treatment

In treatment, the creative use of metaphors and experiential exercises facilitate the treatment process (Hayes et al., 1999). Treatment delivery of ACT ideally is not governed by strictly following a manual. None of the current

available treatment protocols have been officially approved or endorsed by anyone in particular (Yang & McCracken, 2014). Instead, the delivery of ACT is tailored to the individual. The therapist models the targeted behaviour change processes and uses examples from the individual's life, and the therapist's to develop and enhance PF (Luoma et al., 2007).

An effective and experienced ACT therapist remains sensitive to moment-to-moment experiences and behaviour on their part and on the part of the individual. The therapist conceptualises these experiences and behaviour in terms of PF as they take place, acts to promote PF in the individual, assess the impact of their interactions with the individual, and persists or changes patterns of these interaction accordingly. In this way, therapist behaviour has qualities just like the behaviour the therapist aims to promote for the treatment participant; sensitive, open, flexible, and goal-oriented.

4.6 Efficacy of ACT for Chronic Pain

In the past ten years or so, the heightened interest in applying ACT as a treatment model for chronic pain has resulted in the publication of many commentaries and reviews in support of ACT as an effective treatment for chronic pain (Hayes & Duckworth, 2006; McCracken & Morley, 2014; McCracken & Vowles, 2014; Scott & McCracken, 2015) as well as some not in support of it (Hoffman & Asmundson, 2008; Ost, 2008). The evidence is reviewed here.

Delivery modes for ACT interventions have varied and have included individual treatment in a pain center (Wicksell et al., 2008); group residential treatment by an interdisciplinary team of health professionals (McCracken et al., 2005; Vowles & McCracken, 2008), outpatient group-based treatment (McCracken, Sato & Taylor, 2013; Wicksell et al., 2013), self-help workbooks

with minimal therapist support (Johnston et al., 2010; Thorsell et al., 2011); and recently, treatment delivered via the internet (Buhrman et al., 2013; Trompetter et al., 2015a). With technological advancement, smartphone applications (apps) have also been developed for the delivery of ACT, however it appears that none of the apps developed so far have been scientifically tested, certainly none specifically for chronic pain.

Cross-sectional studies generally support greater pain acceptance (McCracken & Vowles, 2006; Viane et al., 2004) and general psychological acceptance (McCracken & Velleman, 2010; McCracken & Zhao-O'Brien, 2010) as related to better physical and psychological functioning. Greater success at engaging in values-based action is also associated with less disability and distress (McCracken & Yang, 2006).

Results from treatment outcome studies further support the role of pain acceptance (McCracken et al., 2005; Vowles & McCracken, 2008; Vowles and McCracken, 2010), and success at values-based behaviour (Vowles & McCracken, 2008) in encouraging better adjustment to chronic pain following treatment. In one particular study, results at 3-months follow-up demonstrated that, independent of changes in pain intensity, increases in PF processes of pain acceptance, general acceptance and values-based action, and mindfulness, were significantly related to improvements in outcomes of depression, anxiety and disability (McCracken & Gutierrez-Martinez, 2011). Good long-term treatment outcomes of ACT measured at three year follow-up have also been demonstrated, where an average medium effect size, $d = 0.57$, was found across domains of depression, anxiety, psychosocial disability and pain-related healthcare visits and a small effect size for physical disability (Vowles et al., 2011).

There is also considerable experimental laboratory evidence in support of ACT for pain, including support for acceptance (Gutierrez et al., 2004; Masedo & Rosa Esteve, 2007; Takahashi et al., 2002; Vowles et al., 2007) and values (Branstetter-Rost et al., 2009; Paez-Blarrina et al., 2008) on experimentally induced pain. In general, numerous experiments demonstrated that individuals in the ACT-based conditions showed an increase in pain exposure time compared to active controls (Branstetter-Rost et al., 2009; Gutierrez et al., 2004; Masedo & Rosa Esteve, 2007; Paez-Blarrina, et al., 2008; Takahashi et al., 2002; Vowles et al., 2007).

Randomised Controlled Trials

There are now a number of RCTs of ACT treatments for chronic pain. To date, there is one early RCT on work related pain and distress (Dahl et al., 2004) and at least 11 RCTs related to ACT and chronic pain (Alonso et al., 2013; Burhman et al., 2013; Kemani et al., 2015; Luciano et al., 2014; McCracken, Sato & Taylor, 2013; Steiner et al., 2013; Thorsell et al., 2011; Trompetter et al., 2015a; Wetherell et al., 2011; Wicksell et al., 2008, 2013) that have included varied treatment delivery modes. Table 4-1 provides a summary of the main characteristics of the RCTs identified.

Table 4-1 Summary of Main Characteristics of ACT RCTs

References	Pain Type.	N (at start)	ACT Interv.	Control Grp(s)	Treatment Duration	Follow-up
<i>Outpatient structured group-based treatment</i>						
Wicksell et al. (2008)	WAD	21	IACT	TAU	8 weeks, 10, 60 min sessions	4 and 7 months
Wetherell et al.(2011)	CP	99	GACT	GCBT	8 weekly, 90 min sessions	6 months
McCracken Sato & Taylor (2013)	CP	73	GACT	TAU	4, 4 hr sessions over 2 weeks	3 months
Steiner et al. (2013)	FM	28	IACT	IPME	8 weekly, 1 hr sessions	3 months
Wicksell et al. (2013)	FM	40	GACT	WL	12 weekly, 90 min sessions	3 - 4 months
Luciano et al. (2014)	FM	156	GACT	RPT WL	8, 2.5 hr sessions	3 and 6 Months
Kemani et al. (2015)	CP	60	GACT	GAR	12 weekly sessions	3 and 6 months
<i>Inpatient residential group-based treatment</i>						
Alonso et al. (2013)	MP	16	GACT	WL	10, 2 hr session over 5 weeks	None. Only post-interv
<i>Self-administered workbook with therapist support</i>						
Thorsell et al. (2011)	CP	90	ACT SH and PS	AR SH and PS	7 weeks	6 and 12 months
<i>Internet-based treatment</i>						
Trompetter et al. (2015a)	CP	238	ACT SH	OEW WL	9-12 weeks	6 months
Buhrman et al. (2013)	CP	76	ACT SH	IDF	7 weeks	6 months

Grp: Group; ACT Interv: Acceptance and Commitment Therapy Intervention; WAD: Whiplash Associated Disorder, CP: Chronic Pain, FM: Fibromyalgia, MP: Musculoskeletal Pain; IACT: Individual Acceptance and Commitment Therapy; GACT: Group Acceptance and Commitment Therapy; ACT SH: Acceptance and Commitment Therapy Self Help; PS: Phone Support; TAU: Treatment as usual; GCBT: Group Cognitive Behavioural Therapy; IPME: Individual Pain Management Education; WL: Wait List; RPT: Recommended Pharmacological Treatment; GAR: Group Applied Relaxation; AR SH: Applied Relaxation Self Help; OEW: Online Expressive Writing; IDF: Internet Discussion Forum; Post-Interv.: Post-intervention.

Results from the RCTs generally support the efficacy of ACT-based treatments for chronic pain in improving physical function and emotional functioning, with mostly small to medium effect sizes demonstrated on outcomes. Collectively, participants in the ACT interventions, compared mostly to inactive control conditions, had lower pain interference ($d = 0.47-1.25$) (Alonso et al., 2013; Trompetter et al., 2015a), lower functional impairment and disability ($d = 0.32-0.75$) (Kemani et al., 2015; Luciano et al., 2014; McCracken, Sato and Taylor., 2013; Trompetter et al., 2015a), lower pain related distress and depression ($d = 0.44 -1.01$) (Buhrman et al., 2013; Luciano et al., 2014; McCracken, Sato & Taylor, 2013; Trompetter et al., 2015a; Wicksell et al., 2008; 2013), pain catastrophising ($d = 0.39-0.89$) (Alonso et al., 2013; Luciano et al., 2014; Trompetter et al., 2015a) anxiety ($d = 0.36-0.85$) (Buhrman et al., 2013; Luciano et al., 2014), and higher satisfaction with life ($d = 0.40-0.75$) (Alonso et al., 2013; Thorsell et al., 2011; Wicksell et al., 2008).

Higher pain acceptance ($d = 0.23-1.21$) (Buhrman et al., 2013; Kemani et al., 2015; Luciano et al., 2014; McCracken, Sato & Taylor., 2013; Thorsell et al., 2011), and general acceptance ($d = 1.39$) (Alonso et al., 2013) were also demonstrated.

Results for pain intensity were mixed, with participants demonstrating lower pain intensity in some studies ($d = 0.28-0.93$) (Luciano et al., 2014;

Thorsell et al., 2011; Trompetter et al., 2015a) and no change in others (Wicksell et al., 2008; 2013). In general, follow-up data from the RCTs support the efficacy of ACT in maintaining improvements in outcomes at three month (Kemani et al., 2015, McCracken, Sato & Taylor; Steiner et al., 2013; Wicksell et al., 2013) and six month follow-up (Buhrman et al., 2013; Luciano et al., 2014, Thorsell et al., 2011; Trompetter et al., 2015a).

ACT appears to be an acceptable treatment for people with chronic pain, with higher treatment satisfaction reported by participants in the ACT group (Steiner et al., 2013; Wetherell et al., 2011) and preliminary results supporting the cost-effectiveness of ACT over an established behavioural treatment of AR at a three month follow-up (Kemani et al., 2015) .

Results from a recent systematic review focused on ACT for chronic pain in adults, concluded that many of the trials so far have included small sample sizes, mostly compared the efficacy of ACT treatments with inactive control conditions, and included a wide range of measures (Hann & McCracken, 2014). On the positive side, the studies were deemed to reflect a high degree of versatility based on the wide variety of modes of delivery tested. Nonetheless, these heterogeneous features make it difficult to reach definitive conclusions on the general efficacy of ACT in chronic pain treatment. What the studies do seem to show is that ACT appears superior to inactive control conditions and may be a good alternative treatment option to traditional cognitive-behavioural based treatments for chronic pain. Larger sample sizes and more high quality studies that include more measures of PF are needed to strengthen and establish the evidence base for the effectiveness of ACT for chronic pain (Hann & McCracken, 2014). Only then can we begin to understand the potential impact of the wider implementation of ACT in clinical practice.

Mediation Analyses

Mediation analyses that have been conducted on ACT support ACT as a theoretically distinct model with distinct methods (Zettle et al., 2011). As discussed in Chapter 3, such analyses are somewhat lacking for CBT.

At least two dozen formal mediation analyses of ACT now exist across a variety of physical and mental health conditions. ACT mediators surrounding general measures of acceptance and PF have shown success in physical health conditions such as obesity (Lillis et al., 2009); diabetes control (Greg et al., 2007); epilepsy (Lundgren et al., 2008); and smoking cessation (Gifford et al., 2004) as well as in anxiety and depression (Forman et al., 2007) and occupational stress management (Bond & Bunce, 2000). Successful ACT mediation has also been demonstrated in specific measures of cognitive defusion (Gaudiano & Herbert, 2006; Hayes et al., 2004; Varra et al., 2008), and values (Lundgren et al., 2008). In more recent studies, ACT has also been found to mediate experiential avoidance (Arch, Wolitzky-Taylor, Eifert, et al., 2012; Niles et al., 2014). Although the quality of these studies are varied, overall findings suggest that the processes within PF mediate treatment outcomes (Hayes et al., 2013).

Mediation analyses have so far also supported the mediating role of PF in the adjustment of chronic pain (Kemani et al., 2016; Trompetter et al., 2015b; Wicksell et al., 2010, 2013). Results from mediation analyses exploring the processes of change in a trial of ACT for chronic pain on disability and life-satisfaction, demonstrated that psychological inflexibility significantly mediated these treatment outcomes, while other variables relevant to traditional CBT-based treatments such as pain, anxiety, depression, fear of movement and self-efficacy did not (Wicksell et al., 2010). Similarly, mediation analyses conducted

in a paediatric pain population also preliminary support the mediating role of PF over variables relevant to CBT-based treatments such as pain, fear of movement and catastrophising in improving function (Wicksell et al., 2011).

Results from a study comparing the mechanisms of PF and pain catastrophising during an online ACT-based treatment also support PF as a central process variable and mechanism of change during ACT (Trompetter et al., 2015b). Both PF and pain catastrophising were found to mediate pain interference and psychological distress at follow-up, while pain intensity was only mediated by PF. As the direct effect of PF on pain interference was found to occur earlier than changes in pain catastrophising the authors concluded that PF, and not pain catastrophising was the more influential change mechanism. A recent study (Kemani et al., 2016) comparing processes of change in ACT and AR demonstrated that pain interference was mediated by improvements in psychological inflexibility only in ACT treatment and not in AR.

Other mediation studies of non-RCT designs also support PF as a mediator of treatment outcomes in ACT. PF has been shown to mediate changes in disability and psychological variables such as depression and pain-related anxiety in a group of patients who completed an interdisciplinary program of chronic pain (Vowles et al, 2014). Variables consistent with PF in this study were also found to significantly mediate treatment outcomes at follow-up. As this study followed a pre-post study design, mediation methods here were not regarded as meeting the same rigorous standard as that of an RCT. A recent exploratory study also demonstrated a trend of acceptance as having a mediating effect on physical functioning but not on satisfaction with life for people with chronic pain (Cederberg et al., 2016). Results from this study are however preliminary due to its exploratory nature and small sample size.

In summary, results from mediation analyses on ACT for people with chronic pain, though preliminary, imply that improvements in outcomes for such patients participating in ACT are specifically mediated only by the therapeutic processes proposed within ACT. These processes of PF appear to perform consistently as mediators across diverse problems targeted by ACT. More mediation studies of ACT are needed to make firm conclusions. This will allow for a further test of the ACT model that can better guide future treatment development.

4.7 Meta-Analysis of ACT in General

A total of three general meta-analyses (Ost, 2008; Powers et al., 2009; Ruiz, 2012) plus two focused on chronic pain (Veehof et al., 2011, 2016) have been conducted on acceptance or ACT-based treatment studies. Results from the earlier general meta-analyses demonstrated a moderate effect size for ACT but did not demonstrate ACT to be more effective than established treatments (Ost, 2008; Powers et al., 2009).

Ruiz (2012) reviewed 16 studies focused on outcome or mediation/moderation type studies that compared ACT and CBT treatments not specific to chronic pain. Out of these, only one study (Wetherell et al., 2011) included a sample of patients with chronic pain. Results from a total of 11 studies found ACT to perform better than CBT on the primary outcome measure, characteristic of each study. Although not found to be significant, measures of depression and quality of life also demonstrated a trend favouring ACT. ACT demonstrated better immediate improvements on quality of life than CBT. When compared to CBT packages using cognitive techniques, ACT was found to have better outcomes ($g = 0.39$).

Ruiz (2012) proposed that for ACT to work through its suggested processes of change, a reduction in experiential avoidance and an increase in cognitive defusion had to be demonstrated, while a reduction in the frequency of automatic thoughts and change in dysfunctional attitudes or behaviours had to be demonstrated for CBT. Results from six out of nine studies supported change processes in ACT (Bond and Bunce, 2000; Flaxman and Bond, 2010; Rost et al., 2012; Twohig et al., 2010; Zettle & Hayes, 1986; Zettle & Rains, 1989) while four studies (Bond & Bunce, 2000; Flaxman & Bond, 2010; Zettle & Hayes, 1986; Zettle & Rains, 1989) failed to support these processes for CBT. Two studies showed mixed results (Arch, Eifert, Davies, et al., 2012; Forman et al., 2012), two did not provide data (Rost et al., 2012; Twohig et al., 2010) and one (Wetherell et al., 2011) focused on chronic pain did not find mediators of change in both ACT and CBT. Overall, compared to CBT ($g = 0.05$), ACT was found to have a greater impact on change processes ($g = 0.38$) with moderate mean effect sizes ($g = 0.40$) favouring ACT (Ruiz, 2012). Ruiz's (2012) review was however limited as it included studies conducted across a broad range of problems, many with small sample sizes. Nonetheless, the current evidence supporting suggested processes of change in ACT appear stronger than evidence supporting the suggested processes of change in CBT (Gaudiano, 2009).

Specific to chronic pain, two meta-analyses on ACT and mindfulness-based treatments have been conducted by Veehof and colleagues (Veehof et al., 2011, 2016). The total number of RCTs of ACT and mindfulness-based treatments for chronic pain may have increased over time, however, results showed that the average quality of studies have not improved significantly (Veehof et al., 2016). As this was not the primary question, it was difficult to

ascertain unique effects of ACT treatment alone. Overall, it was concluded that at present, although there is still no evidence that ACT-based programs and mindfulness-based stress reduction programs are superior to conventional CBT, they continue to represent a potentially good alternative.

4.8 Challenges of ACT and Suggestions for Future Developments

ACT has been criticised on three main grounds. Some researchers and clinicians debate whether (a) ACT includes anything new, (b) is in anyway superior to traditional versions of CBT (Hoffmann & Asmundson, 2008; Ost, 2008), or (c) truly meets the criteria of empirically supported treatments (Ost, 2008). To an extent, these criticisms point to a difference in the level of development of the evidence base between ACT and traditional CBT-based approaches (Yang & McCracken, 2014).

Certainly, supporters of ACT have not claimed that the treatment approach in ACT, and treatment techniques applied in ACT are superior to CBT. In fact, they clearly acknowledge that ACT adopts similar methods to other established therapies such as exposure, behavioural activation, skills training, mindfulness, and methods for building a close and intensive therapeutic relationship, for example (Hayes et al., 1999).

Indeed, in comparison to CBT which is the most established form of psychotherapy, emerging from more than 40 years of broad-based development and dissemination, empirical support for ACT can be generally considered to be in the early phases of development (Yang & McCracken, 2014). The base of research behind ACT is much smaller, the first published RCT did not appear until 2000, and there remain few high quality RCTs in this area. Even so, the American Psychological Association (APA), initiative on evidence based

psychological treatments regards ACT for chronic pain to have moderate to strong research support and recognise ACT as an empirically supported treatment for this condition (Division 12 APA, 2010).

Trials comparing ACT and traditional CBT interventions for chronic pain are few (Wetherell et al., 2011). As already mentioned at the start of this chapter, ACT is essentially a form of CBT, and this makes for difficult comparisons between the two interventions. While acknowledging the differences in philosophical assumptions and treatment process, both ACT and traditional CBT also adopt similar methods in treatment. A competitive situation between some forms of CBT one side and other forms on the other is probably not very productive, at least not as the only means of development. More appropriate means by which to test the superiority of either method might be to consider an examination of treatment processes. Such a test could then lead on to an identification of methods and moderators that lend themselves to greater changes in these key processes, and later to the refinement in methods and procedures. This might lead to better long term change, improved access, more efficient delivery, and potential benefits for treatment providers. However, it may take some time to see which produces more progress over time.

The Need for General and Widely Applicable Treatment Models

One potential area of development for ACT is the ability to test the applicability of the PF model and ACT in culturally and linguistically diverse populations. If the PF model and ACT were truly effective in what they were designed to do, one would expect PF and ACT to be applicable across contexts. Heterogeneity exists between and within cultures (Hwang, 2011) and this includes heterogeneity in contextual features that influence behaviour (Hayes & Toarmino, 1995). Hence, one cannot assume that a model or

treatment that works in one geographical area, culture, language or healthcare system will work equally well in another. This area of research is therefore interesting and important, as findings can attest to the generality of the PF model in a different setting from the one it originated from. The ability to link cultural knowledge to principle based processes of PF, with cultural adaptations in treatment based on functional analyses rather than on geographical and environmental aspects of cultural knowledge may be more appropriate and successful in this case (Hayes & Toarmino, 1995).

Insofar as we are aware, studies of PF and ACT for chronic pain have predominantly been conducted in Western populations from North America and Europe, with no treatment data from Asia (Hann & McCracken, 2014). Only four non-treatment related studies have emerged from East Asia. Three were instrument validation studies. Out of these, two involved validating the Chronic Pain Acceptance Questionnaire (CPAQ) in Hong Kong (Cheung et al., 2008) and Korea (Cho et al., 2012), and one involved validating the Committed Action Questionnaire-8 (CAQ-8) in Hong Kong (Wong et al., 2016). The fourth study is an acceptance-based diary study (Cho et al., 2013) conducted with individuals with chronic pain in Korea. There are some data on CBT treatments for chronic pain in East Asia and Southeast Asia but no data on PF or ACT yet to emerge from Southeast Asia (Yang et al., 2016a).

Conducting ACT-based studies for chronic pain in Southeast Asia allows PF and ACT to be used as tools in the process of developing culturally-adapted psychological treatments for chronic pain in this region, progressing knowledge of human behaviour in this area.

4.9 Mindfulness-based Therapies

Mindfulness represents a combination of several complementary therapy methods and now forms another important part of what has been called the “third wave” of behavioural and cognitive therapies. It was originally derived from Buddhist teaching but has since been integrated into more contemporary approaches to health and behaviour change (Kabat-Zinn, 1990).

Mindfulness has been described as a practice of sustained attention in a posture of open awareness and acceptance of internal and external experiences in the present moment, in a non-judgemental manner (Baer et al., 2006; Kabat-Zinn, 1994). Mindfulness is the process where one is able to start noticing thoughts as just thoughts and feelings and sensations as what they are and nothing more. No verbal judgement need be attached to these thoughts, feelings and sensations. Through the practice of mindfulness, automatic behaviour responses attached to the experiences of physical symptoms, emotions or thoughts are reduced, simply by observing rather than reacting to such experiences (Kabat-Zinn, 1994). The ability to be mindful is understood to result in a more realistic contact with situations and effective action, increasing awareness and reducing the impact of distressing psychological experiences (Baer & Krietemeyer, 2006). Like ACT, the goal of mindfulness is to alter the influence that experiences exert on behaviour rather than changing the content of the experiences themselves.

Like ACT, delivery of mindfulness has gone beyond the traditional face-to-face mode of delivery to include delivery via video conferencing (Gardner-Nix et al., 2008) via the internet and through mobile applications (Krolikowski, 2013).

Mindfulness-based Stress Reduction

Mindfulness-based Stress Reduction (MBSR) is one form of mindfulness based therapy that has typically been used with chronic pain sufferers (Kabat-Zinn, 1990). MBSR follows a structured eight-week program of weekly 2.5 hour sessions and a one day retreat. Group discussions, psychoeducation and practical sessions are also included in the program. The main components of the program include different postures and practice of meditation (sitting and walking), a form of yoga and body scans (Kabat-Zinn, 1990). Approaches such as Mindfulness-based Cognitive Therapy (MBCT; Segal et al., 2002) and Mindfulness-based Relapse Prevention (MBRP; Witkiewitz et al., 2005) although developed from MBSR, include other methods specific to other problem areas, such as relapse following treatment for depression, and relapse after treatment for addiction, respectively.

Efficacy of MBSR Interventions for Pain

Relatively few RCTs have been conducted on MBSR for chronic pain (Veehof et al., 2011, 2016). An early review that included four studies of a pre-post design, showed that MBSR improved pain, general psychological symptoms and other medical symptoms not related to pain, with these improvements maintained at follow-up (Baer, 2003). However, none of these studies were rated for quality, and three out of four studies had reported results based on overlapping participant data. Two recent systematic reviews demonstrated that compared to WL, MBSR significantly improved depression and quality of life in fibromyalgia patients (Kozasa et al., 2012), and was effective in improving outcomes of pain, disability and acceptance in patients with low back pain (Cramer et al., 2012). However, when compared to a health education program, MBSR did not demonstrate an effect on these outcomes

(Cramer et al., 2012). Effect sizes of MBSR treatment were not reported in these reviews, with only combined effects of ACT treatments and MBSR on chronic pain reported in two recent meta-analyses (Veehof et al., 2011, 2016).

Specific to fibromyalgia, data from a meta-analysis of six trials demonstrated that compared to usual care, MBSR showed short-term improvement in quality of life (SMD= -0.35) and pain (SMD = -0.23) (Lauch et al., 2013). Compared to active control conditions, MBSR showed a similar effect for quality of life and a bigger effect for pain but effects were not maintained in the long-term. However, due to the low quality of trials, definite conclusions could not be reached.

The magnitude of the effects of mindfulness-based interventions with people with chronic pain is limited. Higher quality trials are needed to draw definitive conclusions about the efficacy of MBSR for chronic pain. The quality of studies including MBSR interventions can be improved by including better designed trials, larger sample sizes, adequate active control conditions and a period of longer follow up (Chiesa & Malinowski, 2011; Gotnik et al., 2015).

Criticisms of Mindfulness-based Interventions

Studies of mindfulness-based interventions have been criticised on their lack of scientific rigour (Chiesa & Malinowski, 2011). Common criticisms include small sample sizes, a lack of high quality RCTs that include good control conditions, and the frequent use of inactive comparison conditions. Chiesa and Serretti (2010) argued that the absence of active controls does not allow for a clear distinction between specific and non-specific aspects of the mindfulness intervention. Further, differing treatment methods across interventions and an absence of follow-up measures, limited the results of a majority of studies in this area (Toneatto & Nguyen, 2007; Winbush et al., 2007).

The combination of methods typically included in MBSR-based programs makes it difficult to tease apart specific mindfulness related processes in their relations to improved outcomes (Chiesa & Serretti, 2010). At present, it is not conclusive that mindfulness itself, either as method or process, contributed to changes in outcomes. In fact, a clear theoretical framework or a comprehensive set of behaviour change principles appears lacking as a foundation in the development of mindfulness-based approaches (McCracken & Vowles, 2014). Studies examining processes of change within mindfulness are relatively few in number, with even fewer studies attempting to separate component processes within mindfulness. A specific causal role of facets of mindfulness processes or methods has yet to be shown (Carmody & Baer, 2008; Rosenzweig et al., 2010).

Outcomes of mindfulness-based treatments often include improvements in emotional functioning like depression and anxiety, with few demonstrating improvements in physical activity or social functioning (Bohlmeijer et al., 2010; Keng et al., 2011; McCracken & Vowles, 2014). Based on current evidence, it would seem that mindfulness may be more effective for mental health conditions like depression or anxiety, not specific to the condition of chronic pain itself (Hayes et al., 2011). There is relatively little existing evidence to show that mindfulness alone can directly change behaviour especially in the area of chronic pain. ACT is one approach that has shown some success in this area with its combination of mindfulness-related processes and direct behaviour change methods (McCracken, 2013). It seems possible that a greater focus on behaviour change within mindfulness approaches could lead to improvements (Astin et al., 2003; Morone et al., 2008; Schmidt et al., 2011).

4.10 Conclusion

Psychological treatments for chronic pain have evolved in the last half century to include new theories and concepts, new methods of treatment delivery, higher quality treatment trials and more sophisticated treatment interventions. There are definite strengths and promise within treatments that follow the model of ACT. At the same time, the current evidence base reflects no more than moderate empirical support. This is due primarily to the design quality of the RCTs published to this point.

Clearly there is no fully correct and complete model or approach to chronic pain at present, and there is much more progress to make. It remains to be seen what the next decades will bring to the world of chronic pain treatment. For now, at least two developments appear promising: (a) treatments that are more theoretically-based and process-focused, and (b) treatments incorporating information technologies. These developments may particularly address problems such as cost-effectiveness and accessibility that now appear as key challenges.

Chapter 5: Conducting Psychological Research in Non-Western Contexts: The Case for Singapore

5.1 Chapter Overview

The historical background of chronic pain, theories and related treatments has been presented in the previous chapters. In line with the overarching theme of this thesis, an appreciation for conducting culturally sensitive research is presented here. The purpose of this chapter is two-fold: (a) To establish the need for testing psychological theories and models in non-Western contexts, and (b) Provide a rationale for conducting psychological research specific to PF and ACT within the context of Singapore. A brief historical background of Singapore, its people and culture, the healthcare system and the state of psychology services and psychological treatments in Singapore for mental health and chronic pain conditions are described to add a further appreciation of this research context.

The history of Psychology as a scientific discipline appears rather exclusively rooted in European and later American developments. These include the first experimental psychology laboratory opened by Wilhelm Wundt in Leipzig in 1879, and the first American laboratory opened by Stanley Hall in 1883, as examples. Since then, psychological research has evolved to include other forms of applied psychology such as educational theory, behaviour analysis and cognitive science, amongst others. It is no surprise then to see reflected in Psychology, predominantly Western ideas, values, social constructs, and priorities (e.g., British Psychological Society (BPS), origins timeline).

5.2 Generality of Psychological Theories and Applications

An analysis of psychological research conducted between 2003 to 2007 in top journals on six disciplines of psychology, showed that 96% of data were contributed by Western industrialised countries, with 68% of these data coming from US alone (Arnett, 2008). Similarly, Henrich and colleagues (2010) found that a large proportion of data from psychological research is contributed from research studying the mind and behaviour of predominantly “WEIRD” (Western English educated Industrialised Rich Democratic) people. Based on these findings, and assuming it still applies to present time, it would mean that the current psychology evidence base is dominated by research conducted in the western world (Cole, 2006; Sue, 1999). The full extent of diverse human behaviour is therefore unlikely represented, especially if “WEIRD” people characterise only 5% of the world’s population (Arnett, 2008).

Asserting that data contributed from mostly Western samples is valid across cultures, and generalisable across diverse populations, requires demonstrated generalisation of psychological findings across populations with

different histories, languages, cultures and social practices, amongst other differences (Norenzayan & Heine, 2005). Such demonstrations are however lacking in psychological research (Norenzayan and Heine, 2005). In fact, cross-cultural studies demonstrate differences between populations in psychological processes and phenomena such as in the area of attention (Miyamoto et al., 2006), cognitions (Nisbett et al., 2001), self-esteem (Heine et al., 1999), self-constructs (Markus & Kitayama, 1991), modes of reasoning and attributional styles (see Nisbett, 2003; Norenzayan et al., 2007 for a review), as examples. Recent meta-analyses also demonstrate that culturally adapted psychological interventions are more effective than non-adapted interventions for the treatment of mental health conditions in specific cultural groups, including small to moderate effect sizes for psychological functioning ($d= 0.32-0.46$; Benish et al., 2011; Griner & Smith, 2006; Smith et al., 2011).

Collectively, findings from primary studies and meta-analyses imply that cultural factors can contribute to differences in psychological processes and functioning, making it potentially inaccurate to generalise data from one population to another. In fact, there are limited data attesting to the applicability of predominantly Western developed psychological treatment models in non-Western populations. For example, although CBT has substantial evidence base and is a mainstay psychological treatment for many mental and physical health conditions in western populations, the applicability of this intervention to non-Western populations is not well-established (Horrell, 2008). The APA has published guidelines surrounding the inclusion of culture-centred perspectives in psychological research and treatment (APA, 2003). Such recommendations would seem unnecessary if the understanding of psychological processes or

phenomenon can be easily extrapolated from data of western populations to non-Western ones.

So, in order that ideas, values, and practices from psychological research conducted almost entirely in Western contexts are not automatically assumed in societies where they may not be applicable, an examination of comparative data from the remaining 95% of the world's population is pertinent.

5.3 Importance of Culture

Globalisation in the 21st century has allowed for ease of migration and contributed to the creation of a complex mix of interconnected cultures. Cultures are developed through language and traditions of thought and behaviour (Norenzayan & Heine, 2005). Cultural identity which is shaped by the constant interaction with an ever-changing environment is therefore often in-flux and context dependent (Fuchs et al, 2013). Our social world, which includes our cultural affiliations, exerts significant influence on how we think, feel and behave. An individual's behaviour is likely to include constructs and concepts that are culture-specific, encompass shared understandings and an appreciation of social norms that allow one to adapt and function in life, beyond ethnic identity and racial heritage (Peng et al., 1991; Taylor, 1989). In many ways then, ideas about physical health and psychological well-being are also culture bound. In treatment however, individuals are more often viewed in isolation rather than within their multicultural and community context (Hall, 2005), neglecting important socio-cultural factors that may be influencing the individual's behaviour. To counter this tendency, the American Psychological Association Presidential Taskforce (2006) recommends that evidence-based practice in psychology (EBPP) should include the "integration of the best available research with clinical expertise in the context of patient characteristics,

culture and preferences” (American Psychological Association Presidential Taskforce, 2006, p. 271). Psychological intervention is thought to be more effective when it is culturally sensitive (Tharp, 1991). An awareness of cultural influences on behaviour, with an ability to apply relevant psychological theory and tailor treatment to an individual’s circumstances is key in such interventions (Sue, 1998).

At the core of culturally sensitive research and treatment design is the recognition that differing worldviews exist. Here, the cultural context of the study sample is pivotal in guiding the adaptation, delivery and evaluation of treatment (Bernal et al., 1995). Early research in this area which was predominantly focused on mental health services (Rogler, 1987, 1989) has now expanded to include research across wider healthcare settings. Results from these studies broadly demonstrate that higher levels of perceived cultural sensitivity was associated with higher treatment satisfaction (Betancourt et al., 2005), higher treatment adherence (Tucker et al., 2011; William & Rucker, 2000) and better treatment outcomes (Lukoschek, 2003). Health promotion programs and interventions that are designed to be culturally sensitive with minority populations also significantly contribute to the success of these interventions (Sorensen et al., 2005; Winkleby et al., 1997).

Further, an important relationship is thought to exist between culturally sensitive research and external validity of an area under study (Washington & McLoyd, 1982). External validity refers to the extent to which overall findings from a study can be applied and generalised to a wider population or situation (Bernal et al., 1995). Conducting research designed to be culturally sensitive (Rogler et al., 1987), applying appropriately adapted treatment designs (Tharp, 1991) and a consideration of ethnicity in the treatment process (McGoldrick et

al., 1982) strengthens external validity. Hence, studies with sufficient external validity are thought to be culturally sensitive (Bernal et al., 1995). Conducting psychological research and developing treatment that are culturally sensitive can therefore further contribute to the relevance and evidence base of psychological treatment. In this sense, and for the several other points just highlighted here, appreciating the importance of culture and cultural diversity, with an ability to take a culturally sensitive approach in research is essential. This approach forms the basis of the series of studies presented within this thesis.

A Functional Analytic Perspective

Psychology can be regarded as the analysis of behaviour of individuals interacting in and with their environments considered as historical and situational contexts (Hayes & Toarmino, 1995). From a functional analytic perspective, this analysis of behaviour incorporates two levels, individually-based learning contingencies and culturally-based ones (Hayes & Toarmino, 1995).

Human beings are diverse, no two people function in the same way in any given context. For example, Chinese cultures have been shown to be generally high on “collectivism”, with values and cultural practices that are concerned more with the group rather than the individual (Hofstede, 1984; Morris & Peng, 1994). A Chinese person may embody all, many or only some of these cultural practices but we cannot be certain that all Chinese people will adopt all practices. From a behavioural point of view, taking an individuals’ personal history, being sensitive to the individual and his or her needs, and testing workability of strategies through direct experiences with the individual is

key to treatment success. An emphasis on contextual factors within ACT treatment allows for this.

A thorough understanding of human behaviour however requires more than an appreciation of direct influences of behaviours or events. Many influences on behaviour are also “indirect, abstract, arbitrary, and derived” (Hayes & Toarmino, 1995, p. 22). Culture includes these types of influences. In a functional sense, taking into account an individual’s culture within the “act in context” allows for a more adequate analysis of the whole event (Hayes & Toarmino, 1995). For example, a Chinese individual from Singapore is probably unlikely to share many of the same beliefs and experiences as a Chinese individual from China, Hong Kong or Taiwan or a Chinese individual exposed only to Western social influences. Even though these individuals may share a similar history, genetic and otherwise, such individuals are also likely to be exposed to unique influences based in the countries where they grew up. Hence, from a functional analytic perspective, as well as a practical one, a thorough assessment of human behaviour requires not only an understanding of an individual but also an overall understanding of culture-specific characteristics as it influences the individual (Hayes & Toarmino, 1995).

Examining human behaviour with different methods, in different contexts and populations, will add to more meaningful and generalisable findings (Rozin, 2006). Data based on results obtained from studies across diverse sectors of the world’s population can contribute to more effective development, testing, and evaluation in both the assessment and treatment of psychological conditions, lend further support to reliability and validity of data, and provide a more comprehensive understanding of human psychology.

5.4 Extent of ACT Treatment

As already established in Chapter 4, current literature supports the effectiveness of acceptance-based behaviour therapies (ABBT), including ACT and mindfulness, as effective in alleviating general human suffering and distress (Roemer & Orsillo, 2009). Principles of ACT have been broadly applied in both clinical and non-clinical populations with favourable outcomes. These include interventions with a variety of mental health (Arch, Eifert, Davies et al., 2012; Bach & Hayes, 2002; Baer et al., 2005; Bohlmeijer et al., 2011) and physical health conditions (Feros et al., 2013; Gregg et al., 2007; McCracken & Gutierrez-Martinez, 2011; Scott et al., 2016), occupational health and work performance (Bond et al., 2010; Bond & Bunce, 2000; Bond & Bunce, 2003) and general psychological functioning in the student population (Block & Wulfert, 2005; Brown et al., 2011; Muto et al., 2011), as examples. Principles of ACT have also been applied in a wide range of parent-child-adolescent studies (Swain et al., 2015); with preliminary evidence suggesting that ACT is effective in the treatment of children across a variety of presenting problems. Majority of these ACT-based intervention studies have been undertaken in Europe and North America. There remains however, limited research on the relevance to and acceptability of ACT with individuals from other cultures. More evidence is needed to determine the feasibility, acceptability, and efficacy of ACT treatments for these populations.

The only known meta-analysis ($n = 32$) on ACT and mindfulness-based treatments with people from “non-dominant” cultures has been recently published (Fuchs et al., 2013). The meta-analysis did not focus on ACT studies alone but included Dialectical Behavioural Therapy (DBT; Linehan, 1993); MBSR (Kabat-Zinn, 1991), MBCT (Segal et al., 2002) and Culturally-Adapted

CBT (CA-CBT), with analysis conducted across studies rather than by individual treatment model. Results from the meta-analysis preliminary support the utility of ACT and mindfulness-based treatments with people from “non-dominant” cultures (Fuchs et al., 2013). However, majority of the studies included very small sample sizes (median, $n = 28$), included diverse study designs and treatment delivery, from varied settings, populations and age range. The authors conclude that more rigorous studies are needed to confirm these preliminary findings.

A culturally sensitive approach within ACT which matches the characteristics of the treatment with the individual can further inform and help guide the type of treatment adaptations that are needed to tailor treatment for diverse populations (La Roche, 2012). The use of metaphors, concurrently with an emphasis on an individual’s goals and values within the context the individual brings to treatment appears well-suited for people from diverse cultures. The ACT intervention is made more effective when the therapist is able to bring a level of cultural awareness and competence in treatment while concomitantly being mindful of cultural biases that may prevent them from fully considering the worldview of the individual (Sue & Sue, 2003). More evidence generated from culturally sensitive ACT-based research can further strengthen the generalisability of ACT.

Adaptation of Key ACT Measures

Aligned with an increasing interest in PF and ACT, several self-report measures have been developed to measure core ACT processes. These measures include the Acceptance and Action Questionnaire (AAQ; Hayes et al., 2004) and the shorter 7-item Acceptance and Action Questionnaire-II (AAQ-II; Bond et al., 2011), Committed Action Questionnaire (CAQ; McCracken, 2013),

the shorter 8-item Committed Action Questionnaire (CAQ-8; McCracken et al., 2015), and the Cognitive Fusion Questionnaire (CFQ; Gillanders et al., 2014).

Of these, the AAQ and AAQ-II have been the most widely used and adapted measures in research studies involving PF. The AAQ was designed to primarily measure experiential avoidance, while the shortened version of the measure (AAQ-II), designed to measure PF more broadly. The AAQ-II has been adapted for use in a wide variety of conditions such as diabetes (Gregg et al., 2007), cancer (Arch & Mitchell, 2015), acquired brain injury (Whiting et al., 2014), substance abuse (Luoma et al., 2011), weight-related difficulties (Lillis & Hayes, 2008) and chronic pain (McCracken et al., 2004) amongst other instrument variations. The AAQ-II is also available in at least 18 different language variants. Some of these translated versions have been validated in Dutch (Jacobs et al., 2008), French (Monestes et al., 2009), German (Gloster et al., 2011), Portuguese (Pinto-Gouveia et al., 2012), Spanish (Ruiz et al., 2013), and Chinese (Zhang et al., 2014), just to name a few.

Specific to chronic pain, the Chronic Pain Acceptance Questionnaire (CPAQ) which is the adapted version of the AAQ-II for chronic pain has been translated and validated in Cantonese Chinese (Cheung, 2009) and Korean (Cho et al., 2012), and the CPAQ-8 validated in Spanish (Rodero et al., 2010), Swedish (Rovner et al., 2014) and Norwegian (Eide et al., 2016). More recently, the CAQ-8 which is a measure of committed action, has been translated and validated in Cantonese Chinese (Wong et al., 2016) and in Swedish (Akerblom et al., 2016) with a sample of patients with chronic pain.

Overall, the number of disease specific and culture specific adapted ACT-based measures attest to the increasing importance of adapting ACT-based constructs to the characteristics of the study population. A consideration

of the influence of culture in instrument development allows these ACT-based measures to be more sensitive to cultural norms. The ability to demonstrate the relevance of PF in varied settings and across non-dominant cultural groups extends the applicability and scope of PF. This will significantly add to the body of evidence suggesting that ACT's underlying processes influence behaviour in beyond culture, race and ethnicity (Hayes, Pistorello, Levin, 2014; Masuda, 2014).

Psychological Flexibility and ACT in Asia

In Chapter 4, it was concluded that at present, no treatment data on PF and ACT for chronic pain are available in Asia. Conducting culturally sensitive ACT-based studies in Southeast Asia would add to the existing literature on psychological treatments for chronic pain in Asia in general, and on ACT in particular. The rationale and benefits of culturally sensitive research already addressed in the earlier part of this chapter. Singapore, a country in Southeast Asia is potentially an ideal setting in which to conduct this first generation of research. A country that already includes many Western influences yet still bears its own unique history, culture and practices.

5.5 The Context of Singapore

Singapore is a small island city state in Southeast Asia comprising a population of 5.5 million people, with three main communities of Chinese (74.3%), Malays (13.3%) and Indians (9.1%) making up the majority of the country's population (Department of Statistics Singapore). Singapore's British colonial past (1819-1963) and an inter-mix of these groups contribute to its unique cultural heritage and diversity and its unique politics, law, business and finance, healthcare systems and practices, education and the media, which set Singapore apart from the other countries in the region.

Singapore is unique in many ways. Firstly, Singapore is the only country in Southeast Asia where English is spoken as the first language. However, a colloquial version of spoken English, sometimes referred to as 'Singlish' is also commonly spoken between Singaporeans. Secondly, specific to healthcare, a multi-faceted system exists where Western medicine co-exists with several other medical traditions including that of Chinese, Malay and Indian medicine (Quah, 1989). Finally, unlike other countries in Southeast Asia, Singapore is a developed nation, one that is modern, westernised, technologically advanced, with potentially more similarities aligned with Western societies than those of its Southeast Asian counter-parts.

As described, the uniqueness of Singapore provides an interesting and rich context in which to conduct research, especially research relating to cultural influences. Testing psychological theories and models as applied in North America and Europe within a context like Singapore can (a) Identify cultural gaps in the existing literature through an examination of between group differences (b) Consider the implications of cultural factors like language variations in explaining treatment outcomes (c) Improve the use of culturally relevant psychological assessments tools and techniques and (d) Contribute to the development of culturally adapted treatments that may have implications for treatment outcomes.

Singapore's Healthcare System

The healthcare system in Singapore functions on a mixed model delivery of healthcare services. Approximately 80% of primary care services are provided by private sector providers and 80% of tertiary care provided by the public sector. Healthcare services provided for step-down care (e.g. nursing

homes, community hospitals and hospices) are mostly Government funded (Ministry of Health, Singapore^a).

There are a total of 18 polyclinics and approximately 1500 private medical clinics within the community providing primary care. Tertiary care in the public sector is provided by a total of eight public hospitals comprising of six general hospitals, a women's and children's hospital and a psychiatric hospital with another six private hospitals and six national speciality centres contributing additional healthcare delivery. The public hospitals are "re-structured", and are now only partially government funded (Ministry of Health, Singapore^a).

Healthcare Coverage. Coverage for healthcare services in Singapore follows a mixed financing system. Subsidised care is made available for both inpatient and outpatient treatment in the public healthcare system. The most comprehensive medical scheme applicable to most Singaporeans is that of Medisave, a compulsory national medical savings scheme for all working individuals in Singapore (Ministry of Health, Singapore^b). Savings accumulated in the Medisave account can be withdrawn to pay for expenses incurred during hospitalisation, day surgery and for certain outpatient treatments of the account holder and his or her immediate family members (Ministry of Health, Singapore^b). Outpatient treatments for chronic pain, including psychological treatments are not covered under this medical scheme.

5.6 Psychology in Singapore

As of July 2015, a record of 268 registered psychologists in Singapore, approximately one psychologist per 18,000 population, all with a variety of training backgrounds, interests, and specialty intervention areas were believed to be providing care to patients in both the public and private healthcare sector (Singapore Psychological Society, register of psychologists). There is

insufficient data on the register to be certain of the actual number of psychologists working in each area. Among those psychologists that have provided details of their specialisations, only four were identified as having a specialty interest in pain management, with one working in primary care, one in tertiary care, one in academia, and one whose area of work is unknown.

Compared to the US, with 106,500 licensed psychologists (APA, 2014) and the UK with 21,756 registered psychologists (Health Care Professions Council (HCPC), which equates to an estimate of one psychologist per 2,900 population in both the countries, the number of psychologists in Singapore providing treatment for people who require them is substantially small, even more so for those working in the area of pain management. It is possible, that as it is currently not mandatory to be registered to practice as a psychologist in Singapore, that the current register does not accurately reflect the actual number of practicing psychologists. However, this lack of information also implies that proper regulation of credentials and practices of psychologists in Singapore are not in place. This certainly contributes to ambiguity surrounding the standard and quality of care provided by psychologists in Singapore.

5.7 Evidence for Psychological Treatments in Singapore

One of the ways to consider the health care context of Singapore, and the role of psychology within it, is to focus on broader applications of psychological treatments, such as for mental health. According to a recent population based study of mental health disorders conducted in Singapore, a broad review of the literature, in addition to detailed discussions with the relevant stakeholders and mental health experts in the local community led them to conclude that affective disorders, anxiety disorders, including Generalised Anxiety Disorder (GAD) and Obsessive-Compulsive Disorder

(OCD), and alcohol abuse and dependence are mental health conditions that are likely to have the greatest impact on Singapore (Chong et al., 2012). Among the affective disorders, depression had the highest lifetime prevalence of 5.8%, a combined prevalence of 3.6% was found for OCD and GAD, and a prevalence of 3.1% for alcohol abuse and over 0.5% prevalence for alcohol dependence (Chong et al., 2012). In these conditions, the need for psychological services might appear obvious. Even so it appears that studies of treatments of these conditions in Singapore appear relatively unknown.

Cochrane reviews are widely recognised as providing the highest standard and criteria for evidence-based health care, and it is expected that the reach of their search strategies ought to be comprehensive and international (Cochrane Library). Based on the findings from the survey by Chong and colleagues (2012), a search of the Cochrane database for studies published in the last five years on psychological treatment for depression, GAD, OCD and alcohol abuse on data collected from Singapore was conducted (Cochrane Library). None of the reviews in these areas included studies from Singapore. This finding may mean that (a) studies from Singapore exist but were not found, (b) studies from Singapore exist but did not meet the selection criteria (although this was found not to be the case), or (c) there are no studies in these areas from Singapore. Regardless, these findings do not support the existence of a robust base of evidence for these conditions from studies conducted in Singapore.

Specific to psychological treatment studies for chronic pain, none of the main Cochrane reviews in this area (Morley et al., 1999; Eccleston et al., 2009; Eccleston et al., 2014; Williams et al., 2012) included any studies from Singapore. A recent systematic review on psychological treatments for chronic

pain in East and Southeast Asia (Yang et al., 2016a) found only one pre-post study of CBT for patients with chronic pain in Singapore (N = 39) (Tan et al, 2009). This was assessed to be a weak study in design with many limitations. Details of this study are presented in Chapter 6 of this thesis.

In summary, considering the size of the general Singapore population, the number of practicing psychologists providing care to people who need it is small. The lack of regulation of psychological practice leaves much ambiguity regarding the current level of psychological care provided in Singapore. Research data on psychological treatments for both general mental health conditions and more specifically for chronic pain appear limited in Singapore, and the actual effectiveness of psychological treatments provided there is not directly known.

5.8 Conclusion

In this chapter I argue that (a) Psychological theory and models are predominantly developed in Western contexts (b) Much of the data generated as a result of these theories and models are derived from samples based in Western societies, and (c) Without sufficient empirical evidence, the applicability and generality of these theories and data to culturally distinct and diverse populations remain unclear. Singapore is appealing as a fertile study environment in which to test hypotheses and generate new findings. More studies conducted in Singapore are needed to improve treatment efficacy and the treatment experiences of people with chronic pain in this country.

The studies presented in the following chapters are the first of such psychological studies to be conducted in Singapore on chronic pain. Each study is built on the results of previous studies, and feeds into an expanding sensitivity to the role of culture and needs for chronic pain in Singapore. A day

may come when psychological studies are no longer predominantly driven by data from Western societies but include data from a new group, “TRENDI” (Technologically savvy Resourceful English-educated Non-western Diverse and economically-Improving) people.

Chapter 6: Psychological Treatments for Chronic Pain in East and Southeast Asia: A Systematic Review

6.1 Chapter Overview

As discussed in Chapter 5, it appears that much of the research on psychological treatments is conducted in western countries. At present, there appears to be limited knowledge of the development of psychological treatments and the efficacy of such treatments for chronic pain in Asia, including Singapore.

A broad aim of this thesis is concerned with developing a psychologically-based treatment for chronic pain specific to Singapore. For this development to be successful, it is essential to firstly understand the practices, evidence, quality of research and needs related to psychological treatments in Singapore, and the regions surrounding it, as a base for comparison. A systematic review conducted in this area seems an appropriate means by which to fill this knowledge gap.

Through carefully designed questions, a comprehensive search strategy, set inclusion criteria, meticulous data extraction, and synthesis, results from a systematic review provide a reliable summary of evidence (Higgins & Green, 2011). For example, in this case, to answer questions related to (a) extent of available literature, including heterogeneity of studies (b) efficacy of interventions (c) quality of studies and (d) evidence based practice of psychological treatments for chronic pain in these parts of Asia. Results from this systematic review were intended to inform the development of the later phases of this thesis, namely study design and methods for the preliminary treatment study described in Chapters 10 and 11.

A systematic review of psychological treatments for chronic pain was conducted and included only studies from countries in the regions of East and Southeast Asia and not Asia at large. This was an appropriate choice as (a) countries in East and Southeast Asia are within the surrounding geographical regions of Singapore, and (b) relatively similar models of healthcare services appear to exist in these regions. Also shared culture and heritage, economic ties, languages and dialects, and professional affiliations between Singapore and countries in these regions were stronger than with those in other parts of Asia.

An article based on this systematic review is now published: “Yang, S.Y., Moss-Morris, R., McCracken, L. (2016). Psychological treatments for chronic pain in East and Southeast Asia: A systematic review. *Int J Behav Med*, 23(4), 473-484.”. The accepted version of the published paper including minor amendments is included as a chapter here. Citations in the paper have been converted to APA 6th style and included in the references section.

Psychological Treatments for Chronic Pain in East and Southeast Asia: A
Systematic Review

Su-Yin Yang^{1,2}, Lance M. McCracken, & Rona Moss-Morris

¹ King's College London, Health Psychology Section, Psychology Department, Institute of Psychiatry, Psychology and Neuroscience; King's College London, 5th Floor Bermondsey Wing, Guy's Campus, London SE1 9RT.

² Pain Management Clinic, Tan Tock Seng Hospital, 11 Jalan Tan Tock Seng, Singapore 308433

Correspondence to:

Lance M. McCracken, Professor of Behavioural Medicine, Health Psychology Section, Psychology Department; Institute of Psychiatry, Psychology and Neuroscience; King's College London, 5th Floor Bermondsey Wing, Guy's Campus, London SE1 9RT.

Phone: +44 (0)207 188 5410

Fax: +44 (0)207 188 0184

E-Mail: lance.mccracken@kcl.ac.uk

Abstract

Psychological treatments are recognised as generally effective for chronic pain. However, little is known about the evidence for psychological treatments for chronic pain in Asia.

Purpose

This study aimed (1) to identify all treatment outcome studies in the area of psychological approaches to chronic pain in adult populations of East Asia and Southeast Asia and (2) to evaluate the treatment types, the evidence for treatment outcomes and research design quality with regard to these studies.

Search methods

We identified all psychological based treatment outcome studies for chronic pain in East and Southeast Asia by searching CENTRAL, EMBASE, PsycINFO, MEDLINE (via Ovid), Global Health and Web of Science from the beginning of each abstracting service until December 2014 (Week 4).

Results

Seventeen studies met inclusion criteria including a total of N = 1890 participants. Four were randomised controlled trials (RCTs), five controlled clinical trials (CCTs), eight cohort studies. Treatment outcomes included pain, disability, depression and anxiety. Overall, the studies included in this review showed small to medium within group effect sizes for all four outcomes. A majority of the studies were rated as weak in design quality. Three RCTs were found to be of strong quality, one of moderate quality, and only one CCT of moderate quality.

Conclusion

The current available literature on psychological treatments for chronic pain in East and Southeast Asia is generally small in scale, mostly preliminary, and

lags behind on some developments occurring in North America and Europe.
Further development of treatment methods and research designs is warranted.

Keywords: Systematic review; East Asia; Southeast Asia; Chronic pain;
Psychological treatments

Introduction

Chronic pain is a major health problem world-wide that often includes significant impacts on emotional, physical, and social functioning (Breivik et al., 2006; Miller & Cano, 2009). At present, in many pain services, a biopsychosocial approach to treatment is followed, and psychological treatments play an important role particularly Cognitive Behavioural Therapy (CBT) (Eccleston et al., 2009; Williams et al., 2012). Treatments based on CBT are well established in North America and Europe but little is known about the practice of such treatments for chronic pain on other continents, and in other cultures, such as in Asia, particularly East and Southeast Asia.

The East and Southeast Asian Context of Pain Management

Possibly the first conventional modern-day pain clinic in Asia was established in Japan in 1962 (Kitahara et al., 2006) and the concept of multidisciplinary treatment was introduced approximately a decade later. Most pain clinics in Japan, however, are single modality treatment clinics, usually headed by pain clinicians trained in anaesthesia, providing interventional pain treatments, and few pain clinics deliver treatment with a complete biopsychosocial focus (Kitahara et al., 2006; Shiotani, 2001). In most parts of East and Southeast Asia, including Singapore, Malaysia, Indonesia, Philippines, Thailand, Hong Kong and Japan, there appears to be relatively similar models of service delivery. It appears that psychology is usually not included within these services (Cardosa et al., 2012; Nicholas et al., 2006; Tan et al., 2009). In many of the countries in these regions the cost burden of psychological treatment is on the patient. In Indonesia, again as an example, there is no managed care or health insurance system that covers the cost of psychological treatment and hence it is considered unaffordable and is rarely used (Lubis et

al., 2013); with patients preferring to spend their money on medications or medical doctor visits instead. As well as these structural and economic challenges within these healthcare contexts, differing cultural attitudes and beliefs about psychological treatments for chronic pain may present barriers, and require further study (Hayes, Muto & Masuda, 2011; Sue et al., 2009).

So, there are resource limitations, systems within healthcare, and potential cultural differences yet to be understood, that may present barriers to the development and implementation of psychological treatments for chronic pain in East and Southeast Asia. If these are to be eventually overcome, it is important to first assess current psychological treatment developments for chronic pain, effectiveness of these treatments, and the quality of research, in these regions so far.

There are now numerous high-quality systematic reviews of psychological treatments for chronic pain (Eccleston et al., 2009; Hoffman et al., 2007; Veehof et al., 2011; Williams et al., 2012). None of these have focused on nor support specific conclusions about, practices, evidence, nor the quality of the research into such treatments, especially within the Asian contexts identified here. The purpose of the current study is to conduct a review with a specific focus on each of these issues.

Methods

This systematic review was initiated as part of a wider series of projects investigating specific needs for psychological treatment for chronic pain in Singapore. To the best of our knowledge there were no systematic reviews of this kind previously conducted or registered in an international database when the review was planned. In general the focus of this review was on studies of psychological treatments for chronic pain, conducted in East and Southeast

Asia, with adult participants, where the studies were designed to assess the impact of treatment on at least one measure from a set of core clinical outcomes: pain, disability, depression, or anxiety. We chose this set of outcomes because it includes the domains most commonly assessed and reviewed in psychological treatment trials for chronic pain (Veehof et al., 2011; Williams et al., 2012). An additional purpose was to assess the quality of the studies identified.

Literature Search

In order to comprehensively review the published literature on psychologically based treatments for chronic pain in East and Southeast Asia, a search was conducted including the databases of CENTRAL, EMBASE, PsycINFO, MEDLINE (via Ovid), Global Health, and Web of Science. Truncation using the '\$' symbol (wildcard) was used to replace letters in words. This method allowed for retrieval of more search results of the keywords in the search.

In order to identify pain studies this search included the terms “chronic pain” [MesH], “fibromyalgia” [MesH], “rheumatoid arthritis” [MesH], “low back pain” [MesH], “musculoskeletal pain/myofascial pain” [MesH] as search terms for the chronic pain condition. We searched for studies that adopted any widely recognised psychologically-based treatment approaches, including those following a broadly cognitive behavioural model. “Third wave” cognitive behavioural treatment, including acceptance and commitment therapy and mindfulness based treatment methods were also included. The search terms were “psychotherapy” [MesH] or “cognitive therapy” [MesH] or “behaviour therapy” [MesH] or “coping behaviour” [MesH] or “self care” [MesH] or “psychoeducation/education/health education” [MesH].

The search terms “Asia/Southeast Asia” [MeSH] and the respective names of 19 individual countries regarded as part of the East and Southeast Asian region were included in the search. These countries were China, Japan, Hong Kong, Macau, Taiwan, Mongolia, North Korea, South Korea, Singapore, Cambodia, Thailand, Indonesia, Malaysia, Philippines, Laos, Myanmar, Vietnam, Brunei, and East Timor. As Asia is an expansive continent, we chose not to select the countries for this review based on a broader geographical range. To include all countries that make up the Asian continent would be too broad and culturally diverse, and could confuse specific generality. The countries of East and Southeast Asia are not only geographically contiguous, and remote from Europe and North America, but share historical, cultural, and economic ties within a significant Chinese sphere of influence. Coincidentally, professional pain societies of Singapore, Malaysia, Philippines, Thailand, Indonesia and Myanmar have combined together to form the Association for Southeast Asian Pain Societies (ASEAPS). Both Japan and Hong Kong have established pain societies and are recognised in Asia for their relatively advanced pain research and treatment and, particularly, in the case of Hong Kong, for relatively advanced research into psychological treatments.

In addition to the electronic search, references lists from identified studies and relevant journals were also searched by hand to locate potentially eligible studies otherwise missed. A detailed description of the electronic search references lists are attached in Appendix 1.

Study Screening and Selection

The titles and abstracts of identified studies were screened by two reviewers (S.Y. and L.M.) and any discrepancies were resolved by consensus. Only full-length journal articles published in English were further assessed for

eligibility. Studies were not included in the review if (a) they were not East or Southeast Asian-based, (b) participants did not have chronic pain, (c) core outcomes of interest were not assessed, or (d) the study did not evaluate a recognised psychological intervention. Studies that claimed to deliver a psychological intervention but only included education or lectures were not included. A PRISMA Flowchart illustrates the study screening and selection process (See Figure 1).

Quality Assessment

Studies that met criteria were independently ranked for quality, again by the same two reviewers, and any disagreement in the ranking was resolved by consensus. As the selected studies were of mixed study design, with only four Randomised Controlled Trials (RCTs), we used a generic quality ranking tool that allowed for an objective and valid quality ranking across these study types. The quality of studies was ranked according to the Effective Public Health Practice Project Quality (EPHPP) Assessment Tool (www.ehphp.ca/tools.html).

Data extraction Process

A data extraction sheet was developed in Microsoft Excel. The lead author (S.Y.) extracted all data from the selected records. Please see Appendix 2 for details of items included in the data extraction sheet. A second author (L.M.) reviewed and checked the data extraction process for potential inconsistencies; none arose, and results were agreed. Following the data extraction, a table of findings and narrative review were prepared.

Results

A total of 2708 studies were initially located from the search (2300 after removing duplicate records). After removing duplicate studies and studies that did not meet criteria, 15 studies were found: seven from Hong Kong, two from

Japan, two from Malaysia, one from Indonesia, one was from Singapore, one from South Korea, and one from Thailand. Hand searching of references lists and key journals added two more studies from Hong Kong, bringing the total number of included studies to 17, including N = 1890 participants in total. All participants including those in control conditions were included in this total. We report descriptive characteristics of the included studies (Table 1) and where the data were available, within-group effect sizes (Cohen's d) on the respective outcome measures were also reported (Table 2). The data were not regarded as suitable for conducting meta-analyses due to significant heterogeneity in populations, treatment types, research designs, and limited availability of relevant data in the published reports.

Fig. 1 PRISMA flowchart

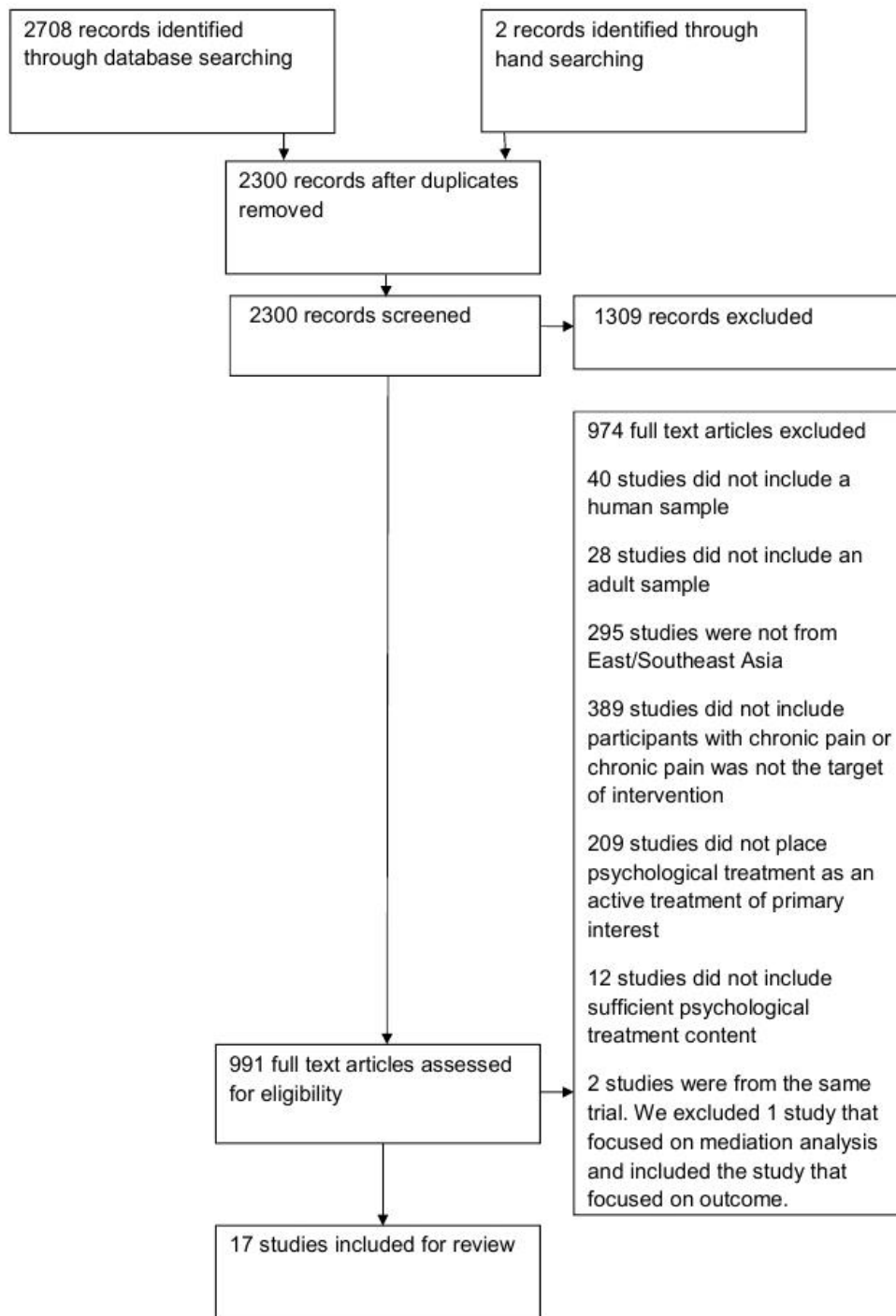

Participants

The majority of the participants (71.9%) were recruited from Hong Kong. With the exception of three studies (Oh & Seo, 2003; Yip et al., 2004; 2007) focused specifically on arthritis, and one study (Vong et al., 2011) focused on low back pain, the remainder of the studies included participants with mixed

chronic pain conditions. A common diagnostic categorisation was to refer to the participants having chronic “non-cancer pain.”

Study Designs and Treatments

Of the 17 studies included, we identified four RCTs of psychological interventions, five controlled clinical trials (CCT), and eight cohort (one group pre + post) studies.

All four RCTs included were two-arm [Li et al., 2006; Tse et al., 2013; Vong et al., 2011; Wong et al., 2011), but these differed in population, treatment content and measured outcomes. The primary focus of Li and colleagues’ (2006) study was on enhancing readiness for return to work (Prochaska et al., 1992) in a group of injured workers. They investigated the effects of a three week training program for musculoskeletal injured workers with long term sick leave who had difficulties resuming their work roles. The training program comprised of both one-to-one vocational counselling and CBT-based group therapy to manage symptoms of stress, pain and anxiety. In contrast, participants in the control group were given advice on job placement by social workers in a community work health centre. Results showed significantly greater improvement in work-readiness, pain, perceived health, and anxiety for the treatment group relative to controls.

Tse and colleagues’ (2013) study focused specifically on the effects of integrated Motivational Interviewing (MI) and physical exercise program in an elderly, community dwelling, Cantonese-speaking population. Participants in the intervention group attended eight weeks, including two main components of MI counselling and physical exercise specifically developed for this population. In contrast, the control group followed regular activities in community centres during the period of intervention. Results showed a significant decrease in pain

intensity and anxiety in the intervention group. Participants in the intervention group also showed significant improvement in self-efficacy to manage pain, an increase in happiness, and a trend toward decreasing depression.

Vong and colleagues (2011) examined an integrated form of Motivational Enhancement Therapy (MET). MET was described as an integration of MI skills and several psychosocial components designed to enhance the motivation for participants to engage in treatment and make appropriate behavioural changes. In this study, participants in the intervention group attended ten weeks of MET plus conventional physiotherapy intervention while the control group attended physiotherapy sessions alone. Results showed a significant between-group effect for motivational status, General Health subscale of the SF-36, and more frequent home exercises, in favour of MET. They also showed a within-group effect for pain intensity, disability and quality of life in the MET group.

Wong and colleagues (2011) compared the effectiveness of a Mindfulness-Based Stress Reduction (MBSR) program with that of a multidisciplinary program (MPI) to manage pain in a mixed group of patients with chronic pain. The intervention followed a typical treatment program of MBSR with a total of 8 weeks of group treatment. There were no statistically significant between-group differences on pain intensity, disability, depression or anxiety. Other results showed significant within-group reduction in pain intensity and pain-related distress for both the MBSR and MPI group. No other significant differences were found on disability, depression and anxiety.

There was a total of five CCTs. Of these, three studies from Hong Kong (Chan et al., 2011; Yip et al., 2004, 2007) evaluated the efficacy of a self-management program based on Bandura's concept of self-efficacy and behaviour change in a group of patients with arthritis pain and a group

diagnosed with “chronic disease” respectively. The study from Thailand (Elsegood & Wongpakaran, 2011) evaluated the effect of guided imagery on affect, cognition and pain in older adults in residential care. The remaining study from South Korea (Oh & Seo, 2003) evaluated the effect of a comprehensive health promotion program for rheumatoid arthritis (CHPPRA) on patients’ levels of pain, depression and disability.

Participants assigned to the control group in both studies conducted by Yip and colleagues (2004, 2007) received routine orthopaedic treatment with no other treatment. The control group in the study by Chan and colleagues (2011) consisted of a waiting list and usual care for 6-months. Outcomes included specific arthritis measures assessed at baseline, one week post-intervention, and at follow-up and 16 weeks in the Yip and colleagues’ studies (2004, 2007) while more generic outcomes were measured at baseline and at 6-months in the Chan and colleagues’ study (2011). Each of these studies found a significant reduction in pain intensity in the intervention groups as compared to the control condition.

Participants in the study by Elsegood and Wongpakaran’s (2011) were older adults living in a Thai residential home. A total of 22 guided imagery sessions were held once or twice a day over a 16-day period. Participants in the intervention group had the option to attend as many group intervention sessions as they wished. During the intervention period, participants also had the option to take part in usual activities which involved daily exercise classes, prayer groups and entertainment activities. Participants in the control group only took part in usual activities. Results showed no significant between-groups or within-group effects in cognition, pain or symptoms of depression, anxiety or stress.

Participants who participated in the study by Oh and Seo (2003) were outpatients diagnosed with rheumatoid arthritis (RA) who made regular visits to the university hospital in South Korea. Participants in the intervention group attended a health promotion group intervention for a total of seven sessions, once a week for approximately two hours over a period of seven weeks while the control group received treatment as usual (TAU) . The intervention included exercise, relaxation skills, pain management skills, knowledge about disease, stress management, positive self-image, rational thinking, problem solving, goal re-setting skills, help-seeking skills and communication skills. Significant between-group differences for pain and depression but not disability were found in favour of the intervention group. Within-group improvement in pain management and psychosocial coping skills were also found for the intervention group. There were no follow-up data.

A total of eight cohort studies were reviewed. Of these four studies focused on the efficacy of CBT-based multidisciplinary programs (Cardosa et al., 2012; Lau et al., 2002; Man et al., 2007; Tan et al., 2009) and two on individually delivered treatments (Abdul Jalil et al., 2009; Kitahara et al., 2006). Although these studies had differing treatment duration, and modes of delivery, results across the studies showed that patients had a decrease in pain levels, were less disabled by pain and had lower levels of emotional distress post treatment; with maintenance of these gains at one month and one year follow up (Cardosa et al., 2012). The study by Lau and colleagues (2002), however, did not include a follow-up. In this study participants had a reduction in pain intensity as measured on a Visual Analogue Scale (VAS), increased knowledge of pain, and significantly better coping on three out of five coping strategies, diverting attention, reinterpreting pain and ignoring sensations.

There were two studies that used relatively unconventional trial designs. One study focused on single discipline (psychologists) delivered CBT-based group intervention (Lubis et al., 2013), with the other focused on a CBT-based group intervention without details of the treatment provider (Matsubara et al., 2010). The study conducted by Lubis and colleagues (2013) had a small sample size, $N = 12$, of those with chronic pain. The overall study included four treatment groups, for anxiety, chronic pain, depression, and insomnia. In this study, participants were allowed to choose their intervention group after being identified as having one of the problems being treated, and the primary analyses were within-group.

The study by Matsubara and colleagues (2010) was also based on a small sample size ($N = 12$). This study considered the effectiveness of a CBT-based activity program between treatment responders and non-responders. The authors described CBT as operant behavioural training with mild physical activity. Operant behavioural training focused on reducing positive attention for pain behaviours and reinforcement of well behaviours such as physical activity. This form of CBT was provided over a six month period in these 12 participants. The authors first classified patients into “effective” and “non-effective” groups based on pain reduction at one month after the beginning of treatment and they then compared these groups on outcomes three and six months later.

Table 1 Characteristics of Included Studies

Author	Study Design	Quality Score	Condition	Mean age (SD)	Intervention	Treatment Type	Sessions (number), duration	N	Attrition Rate %	Outcome Measures
Abdul Jalil 2009	Retrospective Cohort	3	Cancer pain and non-cancer pain	44.7 (SD 15.5)	Multi-disciplinary	Individual Treatment	Not known	169	Not stated	Pain: VAS Disability: modified ODI
Cardosa 2012	Cohort	3	Chronic Pain	42.87 (SD 9.87)	Multi-Disciplinary	Group pre-post	10 days over 2 weeks	102	30	Pain: NRS Disability: RMDQ Depression: DASS
Chan 2011	CCT	2	Chronic Disease	72.57(SD 8.57) (I) 76.05 (SD 7.94) (C)	Mix of lay-led and professional led chronic disease self-management program (CDSMP)	Group N=407 (I) N=365 (C) (WL)	6 sessions, 1x/wk, 2.5hr each	772	25.8 (I) 18.36 (C)	Pain: NRS Disability: 0-3 rating Depression: 0-5 rating
Eisegood 2011	CCT	3	Not specified	73.2 (SD 6.74) (I) 73.5 (SD 6.98) (C)	Guided Imagery	N=16 (I) N=15 (C)	22 sessions 1 or 2x/day over 16 days	31	Not stated	Pain: NRS Depression: GDS (Thai) Anxiety: STAI (Thai)
Kitahara 2006	Cohort	3	Chronic Pain	55.1 (SD 18.2)	Psychosocial	Ind treat.	8-12, 30 min sessions	99	25	Pain: NRS
Lau 2002	Cohort	3	Chronic Pain	47.7 (SD 7.07)	BT	Group pre-post	3, 2 hr sessions in 1 week	19	Not stated	Pain: VAS

Author	Study Design	Quality Score	Condition	Mean age (SD)	Intervention	Treatment Type	Sessions (number), duration	N	Attrition Rate %	Outcome Measures
Li 2006	RCT	1	Chronic Pain	43.23 (SD9.14) (I) 44.8 (SD 7.49) (C)	Multi-disciplinary	34(I) 30(C) (WL)	3 weeks, 3, 1 hr counselling sessions, 1x/day grp training, 2-3hrs	64	0	Pain: SF-36 Disability: SF-36 Anxiety: C-STAI
Lubis 2013	Cohort	3	Chronic Pain Anxiety Dep Insomnia	Not available for chronic pain group.	CBT	Group. 12 (Chronic Pain), 8 (Anxiety), 12 (Depression), 11 (Insomnia)	8 sessions over 4 wks, 2x/wk, 2.5 hr/session	43	16.7	Depression: CES-D Anxiety: STAI-6
Man 2007	Cohort	3	Chronic Pain	42 (median age)	Multi-Disciplinary	Group pre-post	14 days over 6 wks	49	8.2	Pain: VAS Disability: SF-36 Depression: HADS (Chinese) Anxiety: HADS (Chinese)

Author	Study Design	Quality Score	Condition	Mean age (SD)	Intervention	Treatment Type	Sessions (number), duration	N	Attrition Rate %	Outcome Measures
Matsubara 2010	Cohort	3	Chronic Pain	54.7 (SD 18.3)	CBT	Group pre-post	6 mths	12	0	Pain: NRS Depression: HADS Anxiety: HADS
Oh 2003	CCT	3	RA	48 (SD 7.50)	Comprehensive health promotion program for RA	N=18 (I) N=18 (TAU)	sessions over 7 weeks, 2 hrs each session	36	0	Pain: VAS Disability: 26 item Likert type scale by Jung Depression: CES-D
Tan 2009	Cohort	3	Chronic Pain	47.15 (range 25-78)	Multi-disciplinary	Group pre-post N=29 (full prog) N=10 (pacing)	6-9 days over 2 weeks (I) 2 days, bi-weekly pacing program	39	38 (full prog) 10 (pacing)	Pain: NRS Depression: DASS Anxiety: DASS
Tse 2013	RCT	2	Chronic Pain	75.9 (SD 6.4) (I) 77.2 (SD 5.1) (C)	Motivational Interviewing Exercise (I) TAU (C)	N=31 (MIE) N=25 (C)	8 weeks, 1x/wk, 1.5hr	56	3(I) 4(C)	Pain: NRS Disability: SF-12(Chi) Depression: GDS-SF(Chi) Anxiety: C-STAI

Author	Study Design	Quality Score	Condition	Mean age (SD)	Intervention	Treatment Type	Sessions (number), duration	N	Attrition Rate %	Outcome Measures
Vong 2011	RCT	1	Low back pain	44.6(SD 11.2) (I) 45.1 (SD 10.7) (C)	Motivational Enhancement Therapy + Physiotherapy (I) Physiotherapy (C)	N=38 (MET+PT) N=38 (PT)	10 sessions over 10 weeks (30 min each session)	76	26.3 (I) 28.9 (C)	Pain: VAS Disability: RMDQ
Wong 2011	RCT	1	Chronic Pain	48.7 (SD 7.84) (I) 47.1 (SD 7.82) (C)	MBSR (I) Multidisciplinary pain intervention (C)	N=51 (MBSR) N=48 (MPI)	8 wks. 1/wk, 2.5 hr with a 7 hr retreat session	99	23 (I) 10 (C)	Pain: NRS Disability :SF-12 (Chi) Depression: CES-D(Chi) Anxiety: C-STAI
Yip 2004	CCT	3	Arthritis	81.99 (CI:79.6-84.5) (I) 85.15 (CI:83.7-87.9) (C)	Nurse-led Arthritis self-management program	Group Pre-post N=23 (ASMP) N=19 (C)	6, 2 hr classes, 1x/wk	42	8.7 (I) 15.8 (C)	Pain: VAS Disability: HAQ Depression: CES-D
Yip 2007	CCT	3	Arthritis	65.6(SD 9.66)(I) 64.02(SD 9.94) (C)	Nurse-led Arthritis Self-Management Program	N=88 (I) (ASMP +TAU) N=94 (C) (TAU)	6, 2 hr classes, 1x/wk	182	10.2(I) 25.5 (C)	Pain: VAS Disability: HAQ

RCT, randomised controlled trial; CCT, controlled clinical trial; RA, rheumatoid arthritis; CBT, Cognitive Behavioural Therapy; MBSR, Mindfulness-based Stress

Reduction; Psychosocial: includes mainly education, exercise, goal setting, medication management and cognitive and behavioural techniques; Multi-disciplinary:

includes mainly pain education, CBT-based techniques, exercise, functioning activities; C, control group; I, intervention group; WL, wait list; TAU, treatment as usual;

VAS, visual analogue scale; NRS, numerical rating scale; HADS, Hospital Anxiety and Depression Scale; DASS, Depression Anxiety Stress Scale; CES-D, Centre for

Epidemiological Studies-Depression Scale; GDS, Geriatric Depression Scale-Short Form; SF-36, Medical Outcomes Survey Short

Form-36; SF12; Medical Outcomes Survey Short Form-12; HAQ, Health Assessment Questionnaire, ODI, Oswestry Disability Index; RMDQ, Roland Morris Disability

Questionnaire; STAI, State Trait Anxiety Inventory; C-STAI, Chinese-State Trait Anxiety Inventory; Chi, Chinese.

Quality Score: 1 = strong, 2 = moderate, 3 = weak

Treatments Summary, Quality of Delivery and Effect Sizes

Nine studies (52.9%) included CBT-based interventions. Of the remainder, three studies were described as specifically based on Bandura's self-efficacy model, two studies were based on MET, one study was a mindfulness-based intervention, one study was a guided imagery intervention, and one study was a health promotion intervention. Except for the two MET studies, the remaining seven (41.2%) studies described the use of a standard manual for treatment intervention.

The consistency and standard of delivered treatment across a majority of the studies was unclear. Psychological treatments were delivered by a trained psychologist in five out of the 17 studies (29.4%). Registered nurses/social workers delivered psychological treatment in five (29.4%) studies. In one study, psychological treatment was co-delivered by physiotherapists with registered nurses. Treatments were delivered by a "pain physician" and an anaesthesiologist in two studies and physiotherapists in one study. In one study, researchers who designed the intervention program delivered treatment, and the training and experiences of the researchers were not described. The remaining two studies did not describe the person nor the training and experiences of the person who delivered treatment. Overall the training experiences of the health professional delivering psychological treatment were described at least minimally in seven studies and were unclear in ten studies (58.8%).

Average length of treatment for the psychological treatments was 6.6 weeks, based on 15 studies. Information provided by two of the studies was not included as they only provided a time range rather than a single value. The average number of sessions was 8.3 sessions based on 11 studies. Studies

were not included if they did not explicitly describe the delivery of the intervention in terms of sessions but rather in terms of number of days. Average treatment duration of 12.9 hours was based on ten studies. The remaining studies did not have complete data of which to extract details on the number of treatment sessions and/or duration of each session.

The outcomes measured were not uniform across studies. All studies except for one included an assessment of pain. There were roughly equal numbers of studies utilising either the numerical pain scale of 0-10 and the VAS for pain assessment. Eleven studies assessed disability with a range of different measures. Depression was assessed in 11 studies and anxiety in eight studies. Catastrophising was also measured as an outcome in three of the studies.

Effect sizes were calculated for studies that provided pre- and post-intervention means and standard deviations for one or more of the following outcomes: (a) pain intensity, (b) disability, (c) depression and (d) anxiety. Effect sizes were only calculated within groups over time as relatively few of the studies employed control conditions. Cohen's d (Cohen, 1988) was calculated taking the difference in means between post- and pre-treatment where

$$d = \frac{X_{1(\text{post-treatment})} - X_{0(\text{baseline})}}{SD_{(\text{baseline})}}$$

Only three studies (Man et al., 2007; Tse et al., 2013; Wong et al., 2011) provided data for all four outcomes. We were able to calculate within-group effect sizes for pain intensity from 12 studies, effect sizes for disability and depression from nine separate studies, and anxiety from seven studies. Three studies did not provide adequate data for calculation of effect sizes (Abdul Jalil

et al., 2009; Chan et al., 2011; Kitahara et al., 2006) hence data from these studies are not reflected in the table below. Table 2 presents summary effect sizes.

Table 2: Uncontrolled (within-group) Effect Sizes for Pain Intensity, Disability, Depression and Anxiety

Study	Pain Intensity (<i>d</i>)	Disability (<i>d</i>)	Depression (<i>d</i>)	Anxiety (<i>d</i>)
Cardosa 2012	0.70	1.15	0.60	-
Elsegood 2011	0.61	-	0.21	0.16
Oh 2003	0.60	0.13	0.90	
Lau 2002	0.46	-	-	-
Li 2006	0.24	0.06	-	0.54
Lubis 2013	-	-	0.55	1.86
Man 2007	0.12	0.14	0.04	0.14
Matsubara 2010	1.30	-	-	-
Tan 2009	0.39	-	0.57	0.55
Tse, 2013	0.61	0.32	0.40	1.40
Vong 2011	0.90	0.86	-	-
Wong 2011	0.38	0.07	0.23	0.13
Yip 2004	-	0.46	0.45	-
Yip 2007	0.63	0.24	-	-

There were mostly small to medium effect sizes for pain intensity, with two studies (Matsubara et al., 2010; Vong et al., 2011) showing a large effect size. One of these (Matsubara et al., 2010), however, was limited by a small sample size and its study design. Pre-dominantly small effect sizes were obtained for disability, with only two studies (Cardosa et al., 2010; Vong et al., 2011) obtaining large effect sizes of $d = 1.15$ and 0.86 respectively. Except for one study (Oh & Seo, 2003) with a large effect size of 0.90 for depression, mostly small to medium effect sizes of $d = 0.04$ to 0.60 were obtained for depression, and anxiety, $d = 0.13$ to 0.55 . Two studies showed large effect sizes of $d = 1.86$ (Lubis et al., 2013) and $d = 1.40$ (Tse et al., 2013) for anxiety

with small to medium effect sizes of $d = 0.13$ to 0.55 obtained for the remaining five studies. Again, the study by Lubis and colleagues' (2013) is limited by a small sample size and a study design that appears particularly open to bias. Overall, a majority of the studies included in this review yielded small to medium effect sizes for outcomes of pain intensity, disability, depression and anxiety respectively.

Study Quality

Table 1 provides a summary of the study characteristics and their quality rankings. Study quality was rated on the following: (a) selection criteria, (b) study design, (c) type and percentage of confounds, (d) blinding, (e) use of valid and reliable measures and (f) rate of withdrawal or drop-outs. Based on the Global rating guidelines of the EPHPP quality assessment tool (www.ephpp.ca/tools.html), studies were rated "strong" if there were no weak ratings across these six items, "moderate" if there was one weak rating and "weak" if there were two or more weak ratings.

Out of the 17 studies included in this review, three were regarded as strong in quality (Li et al., 2006; Vong et al., 2011; Wong et al., 2011) and two of moderate quality (Chan et al., 2011; Tse et al., 2013). A majority of the studies (12 out of 17) were rated as weak in design quality. All three studies with a strong quality rating were RCTs.

Discussion

This review contributes to a first summary assessment of the quantity, characteristics, results, and quality of studies of psychological interventions for chronic pain in East and Southeast Asia. A primary finding is that a relatively small number of published studies were found from this relatively large and highly populated part of the world. The first study of any design appeared in

2002 and the first RCT in 2006. These studies were by no means evenly distributed across the regions addressed here, with more than three quarters of the studies conducted in Hong Kong, Japan, and Malaysia combined, and twelve of the nineteen countries in the search yielding no studies. Most of the studies reviewed here included forms of CBT, defined very broadly, in group-based settings, for people with mixed chronic pain conditions. Overall the results of the studies reviewed appear supportive of psychological treatments for pain in East and Southeast Asia. The studies produced predominantly small to medium uncontrolled effect sizes for pain, disability, depression and anxiety. In general the design quality of the studies reviewed here is low, few studies included randomisation, and sample sizes were often small, appropriate for preliminary or pilot studies but not definitive ones.

The relatively small number of trials found, the very small number of RCTs, and the recent appearance of these in Asia are remarkable given the long history of psychological treatment development in North America and Europe (Turk et al., 1983). In fact an early meta-analysis of trials of multidisciplinary treatment for pain, including 65 studies, appeared in 1992 (Flor et al., 1992) and an early Cochrane review on psychological treatment for chronic pain, including 25 trials, appeared in 1999 (Morley et al., 1999), thus demonstrating the extent of much earlier development in North America and Europe.

The treatments studied here varied in format and content. The range of treatment duration is estimated between 6 and 27 hours, with a mean of 12.9 hours over an average of 8.3 sessions. Not all of the studies provided a detailed description of the number of individual sessions and duration of the individual sessions. Descriptions of treatment content were often insufficient to judge the

type and quality of the specific methods being used, or such issues as competency and fidelity. Apart from six studies (Cardosa et al., 2012; Chan et al., 2011; Elsegood & Wongpakaran, 2011; Wong et al., 2011; Yip et al., 2004, 2007) a majority of the interventions apparently did not follow a manualised treatment protocol, and the psychological interventions were not delivered by trained psychologists. It was unclear in some cases whether the treatment providers were trained to an acceptable standard in the delivery of treatment being studied. Studies have shown that differences between therapists delivering treatment can confound treatment efficacy (Kim et al., 2006; Wampold & Serlin, 2000). Therapist effects do exist (Lewis et al., 2010) and can be associated with a decrease in the estimate of treatment effect sizes (Kerry & Bland, 1998). Competency is important, as a poor treatment outcome may be due to inadequate delivery rather than the treatment model itself. This can bias the results obtained.

Only three of the studies reviewed reported the full set of primary outcomes that we employed in study selection. These outcomes were adopted from the Cochrane review (Williams et al., 2012) on psychological interventions for chronic pain and are also recommended outcomes by the Initiative on Methods, Measurement and Pain Assessment in Clinical Trials (IMMPACT) (Dworkin et al., 2005). IMMPACT recommendations have been widely cited and now standardly guide the design of clinical trials and other types of clinical research. A majority of studies only reported three out of the four outcomes. The measures selected within each study as primary outcome also differed.

A majority of the studies were ranked as weak in quality with only three of the studies (Li et al., 2006; Vong et al., 2011; Wong et al., 2011), all RCTs, ranked as strong in quality and two studies; one RCT (Tse et al., 2013) and one

CCT design (Chan et al., 2011) ranked of moderate quality. Caution, however, should be taken in the interpretation of the quality ranking of the studies that were ranked of strong quality. As we chose a generic quality assessment tool that allowed us to measure quality across different study designs, it is possible that the standards set by the assessment tool may be lower than that of a tool measuring the quality of predominantly RCTs. For example, we did not use a standard risk of bias tool (Higgins et al., 2011) in assessing our studies as the tool is specific to assessing RCTs. The three studies that were ranked high in quality on this quality assessment tool may rank lower on a quality assessment tool specific for RCTs.

A majority of studies described in this review appeared to utilise a less than stringent criteria in their participant selection, study design, and data collection methods, compared to more widely disseminated RCTs conducted in North America or Europe. Relatively small sample sizes and a poorly described treatment intervention were common limitations in the studies reviewed here. The number of studies in Asia lags significantly behind the more research-productive regions of the world, with only half of the studies published in peer reviewed international journals and only in the past ten years. This relatively low rate of publication and relatively lesser design quality potentially suggest (a) research involving non-surgical and non-pharmacological treatment of pain may not be of priority across healthcare settings in East and Southeast Asia, (b) resources available for research in the area of chronic pain may be lacking, or (c) there may be limited availability of systems for delivery of psychological treatments and trained providers (Cardosa et al., 2012). There is little reason to believe that the need for effective treatments is less in East and Southeast Asia than in any other part of the world.

Setting aside the higher risk for bias within the Asian studies relative to those typically reviewed from North America and Europe the uncontrolled effect sizes here are of a similar magnitude to between-groups effect sizes found in other recent reviews from these latter regions (Eccleston et al., 2009; Morley et al., 1999; Williams et al., 2012). Although, this is an admittedly hazardous comparison to make, again, the quality of study designs, and possibly treatment quality, clearly varies greatly between those conducted in Asia and those conducted in North America and in Europe. At the same time, there are other similarities that emerge regardless of region. Studies in Europe and North America also include significant quality limitations (Williams et al., 2012). There is a lack of demonstrated effects relative to active treatment comparison conditions. The treatments are often packages of methods that obscure the active ingredients. There is a lack of long-term outcome data. There is also not enough analysis of mediation or treatment process (what needs to change to produce good results), or moderation (who does better with which treatments) (McCracken & Morley, 2014; Williams et al., 2012). As the quality of study designs improves treatment effect sizes appear to shrink (Eccleston et al., 2009; Williams et al., 2012), it remains to be seen whether this same trend will be repeated in future studies in Asia from this point forward. In any case, the systematic reviews and meta-analyses of trials from countries with more developed pain research now conclude that there is no further need for RCT of CBT as have been done to this point, and that different research strategies are needed, such as to address the design limitations listed above (Williams et al., 2012). This may mean that some research efforts in Asia can also move on to this next generation of research: dismantling studies, studies focused on process and mediation, moderation analyses, and the like. Either way there

does remain the reality of a design quality gap to be filled, one that may be based primarily in research infrastructure and the availability of funding, as implied earlier.

Limitations

This review has a number of limitations. Firstly, a limitation of our study is that it provides an incomplete view of Asia. The Asian continent spreads across a vast area of countries and languages. Based on our current available resources, we were unable to conduct a systematic review of the whole of Asia as such. We were also limited by the existing arbitrary geographical demarcation of regions within Asia which guided our choice of countries to focus our review on.

Although an extensive search of the databases was conducted, it is possible that studies were missed, particularly studies that were published in journals local to their country, and were not indexed in the databases that were searched, or appeared in other languages. Although we attempted to hand search articles, due to the limited number of studies published, this yielded few additional studies. As a result of the limited number of studies found, we chose not to use stringent criteria to include only RCTs. With the diversity of study design and treatment content as well as outcome measures, it was difficult to compare results across studies, and we were unable to produce a quantitative synthesis. As only half of the studies had control groups, to maintain consistency across studies, we only report effect sizes within-groups over time and not between-groups. These are more vulnerable to bias and may provide an inflated estimate of treatment benefits. Being able to report between-group effect sizes and meta-analyses, and to present forest plots would have strengthened the conclusions from the evidence in this review. The four

outcomes of pain intensity, disability, depression and anxiety were not consistently measured across studies. We were therefore unable to obtain effect sizes across these four outcomes for all studies.

We included only articles published in the English language, as English is the common language understood by the three authors of this review. We were unable to provide analyses of research in any other language in a comprehensive fashion. This language issue is a pertinent one, and worth emphasising, as a purpose of this review was to understand the amount or extent of research in this region. The high diversity of languages in the Asian regions reviewed here, relative to higher consistent use of English in research writing in Europe and North America, may mean that we have missed a significant number of potential studies. In fact, during our search we did uncover studies published in other languages native to East and Southeast Asia, including Korean, for example. Hence, our methods will to some degree underestimate the number of studies of psychological pain treatments in Asia.

We also acknowledge the potential of publication bias in the synthesis of data here. Publication bias occurs when studies with significant findings are made more likely to be published than those with non-significant findings (Dubben & Borholt, 2005; Franco et al., 2014). Overall findings in this review were based primarily on a review of published studies. Publication bias should therefore be taken into account when interpreting results presented here.

Conclusion

In their own conclusions the authors of the studies reviewed here present an optimistic view of the role for psychological treatment of chronic pain in East and Southeast Asia. However, taken as a whole, the literature is limited in a number of ways, generally small in scale, potentially open to bias, and

preliminary. Further development of treatment methods and research designs, and more rigorous testing of the efficacy of psychological treatment for chronic pain in East and Southeast Asia are warranted. This area of research is important and appears necessary to reduce the adverse impacts of chronic pain and improve the health and well-being of those with significant chronic pain within this large, culturally distinctive, and highly populated region of the world.

Informed Consent Statement

All procedures followed were in accordance with the ethical standards of the responsible committee on human experimentation (institutional and national) and with the Helsinki Declaration of 1975, as revised in 2000. Informed consent was obtained from all patients for being included in the study.

Conflict of Interest Statement

Su-Yin Yang, Lance McCracken and Rona Moss-Morris declare that they have no conflict of interest.

Appendix 1

Search Strategy

Search Terms for Pain

- 1 exp chronic pain/
- 2 "chronic pain".mp.
- 3 exp fibromyalgia/
- 4 "fibromyalgia".mp.
- 5 exp rheumatoid arthritis/
- 6 ("arthritis" or "osteoarthritis").mp.
- 7 exp low back pain/
- 8 "low back pain".mp.
- 9 exp musculoskeletal pain/ or exp myofascial pain/
- 10 "musculoskeletal pain".mp.

Search Terms for Psychological Treatment

- 11 exp psychotherapy/
- 12 "psychotherapy".mp.
- 13 exp cognitive therapy/
- 14 "cognitive therapy".mp.
- 15 "cognitive behavior therapy".mp.
- 16 exp behavior therapy/
- 17 "behavior therapy".mp.
- 18 ("acceptance and commitment therapy").mp.
- 19 "mindfulness".mp.
- 20 exp coping behavior/
- 21 "coping skills".mp.
- 22 exp self care/
- 23 "self management".mp.
- 24 exp psychoeducation/ or exp education/ or exp health education/

25 "psychoeducation".mp.

Search Terms for Countries in Southeast Asia

26 exp Asia/ or exp Southeast Asia/

27 "Southeast Asia".mp.

28 "East Asia".mp.

29 "Singapore".mp.

30 "Singapore\$".mp.

31 "Cambodia".mp.

32 "Cambodia\$".mp.

33 "Thailand".mp.

34 "Thai\$".mp.

35 "Indonesia".mp.

36 "Indonesia\$".mp.

37 "Malaysia".mp.

38 "Malaysia\$".mp.

39 ("Philippines" or "Filipino").mp.

40 "Laos".mp.

41 "Lao\$".mp.

42 "Myanmar".mp.

43 "Myanm\$".mp.

44 "Vietnam".mp.

45 "Vietnam\$".mp.

46 "Brunei".mp.

47 "Brunei\$".mp.

48 "East Timor".mp.

49 "East Timor\$".mp.

50 "China".mp.

51 "Chinese".mp.

- 52 "Japan".mp.
- 53 "Japan\$".mp.
- 54 "Hong Kong".mp.
- 55 "Macau".mp.
- 56 "Taiwan".mp.
- 57 "Taiwan\$".mp.
- 58 "Mongolia".mp.
- 59 "Mongolia\$".mp.
- 60 "Korea".mp.
- 61 "North Korea".mp.
- 62 "South Korea".mp.
- 63 "Korea\$".mp.

Appendix 2

Items included in the Data Extraction Sheet

1. Study ID
2. Date of data extraction
3. Identification features of the study [author(s), article title, source (Journal, year, volume, pages, country of origin), institutional affiliation (1st author)]
4. Study characteristics [sample size, population from which study was drawn, inclusion/exclusion criteria, recruitment procedures]
5. Characteristics of participants at intervention commencement [age, ethnicity, sex, diagnosis, pain duration, % agreed to participate, number of participants randomised in each condition (for randomised trials), intervention and control groups comparable at baseline, blinding]
6. Methods [design, type of study, objectives specified in methods section]
7. Interventions [number of conditions (including control condition), description of intervention, duration of intervention, who delivers the intervention, what special training was provided for treatment delivery providers, was the intervention manualised]

Chapter 7: Mixed Experiences and Perceptions of Psychological Treatment for Chronic Pain in Singapore: Scepticism, Ambivalence, Satisfaction, and Potential

7.1 Chapter Overview

The experience of pain is a quintessentially subjective one. It is a private experience that is influenced by a wide range of contextual factors, including cognitive, affective, cultural and social ones. Attempts to quantify pain and patient responses in treatment are therefore potentially challenging.

Understanding pain and issues surrounding it from direct patient experiences, and in their own words, can represent an alternative way to examine the person with pain and their behaviour. Qualitative approaches which are inductive and grounded in the data are potentially useful tools in this process (Osborn & Rodham, 2010). Qualitative approaches also allow for a study of contexts and processes not amenable to experimental manipulation.

As mentioned in Chapter 5, specific to the context of Singapore, there appears to be a lack of psychology resources in general, with few of the practicing psychologists interested in chronic pain treatment. This means that only a small sample of people with chronic pain eligible for psychological treatment have been able to gain access to this form of treatment for their pain condition. Insofar as we are aware, the evidence for the efficacy of psychological treatments for chronic pain in Singapore is limited and the understanding in the day to day treatment even more so (Tan et al., 2009, Yang et al., 2016a).

A qualitative study examining patients' perceptions, experiences, and their understanding of health professionals' advice regarding psychological treatment for chronic pain can inform development, future research and eventual evidence based practice. As part of a wider research strategy it could lead to changes that influence referral patterns, potentially alter patient-healthcare professional communication, improve access and engagement with psychological treatment and could contribute to more effective treatment for chronic pain in Singapore.

A qualitative study was conducted on patients' perceptions and experiences of psychological treatment for chronic pain in Singapore. An article based on this study is published in "Yang, S.Y., Bogosian, A., Moss-Morris, R., McCracken, L. (2015). Mixed experiences and perceptions of psychological treatment for chronic pain in Singapore: Skepticism, ambivalence, satisfaction, and potential. *Pain Med*, 16, 1290-1300.". The accepted version of the paper is included here. Citations in the paper have been converted to APA 6th style and included in the references section.

Participant informed consent for this study is included in Appendix A and the final version of the coding manual included in Appendix B.

Mixed experiences and perceptions of psychological treatment for chronic pain
in Singapore: Scepticism, ambivalence, satisfaction, and potential

Su-Yin Yang*^{1, 2} (MSc Health Psychology), Angeliki Bogosian³ (PhD Health
Psychology), Rona Moss-Morris¹ (PhD Health Psychology), & Lance M.
McCracken¹ (PhD Clinical Psychology)

¹ King's College London, Health Psychology Section, Psychology Department

³ City University, School of Arts and Social Sciences, Department of Psychology

Correspondence to:

Su-Yin Yang, Health Psychology Section, Psychology Department , Institute of
Psychiatry, King's College London, 5th Floor Bermondsey Wing, Guy's Campus,
London SE1 9RT.

Phone: +44 (0)207 188 5410

Fax: +44 (0)207 188 0184

E-Mail: su-yin.yang@kcl.ac.uk;

²Pain Management Clinic, Tan Tock Seng Hospital, 11 Jalan Tan Tock Seng,
Singapore 308 433

E-Mail: su_yin_yang@ttsh.com.sg

Phone: +65 6357 8352

Fax: +65 6357 2155

**Disclosure: The authors declare that they have no conflicts of interest
related to this study.**

Abstract

There is little research in Southeast Asia focusing on patients' experiences of seeking psychological treatment for chronic pain.

Objective: This study aims to understand the experiences of patients seeking psychological treatment for chronic pain in this region.

Setting: Outpatient pain clinic at a tertiary hospital in Singapore.

Subjects: People with experiences of attending psychological treatment for chronic pain, including some who were not receiving this type of treatment.

Study design and methods: Fifteen inductive semi-structured interviews were conducted to explore patients' experiences regarding psychological treatment for their chronic pain. Thematic analysis was then applied.

Results: Three main themes were identified: 'Expectations and Realities of Health Professionals', 'Patients' Attitudes and Beliefs' and 'Practical and Social Factors.' From the patients' perspectives, an empathetic health professional who was willing to listen contributed to a positive treatment seeking experience. Patients felt that health professionals' lack of knowledge about appropriate treatment contributed to their frustration. Patients could not understand how psychological treatment was related to pain treatment and queried why they were "paying just to talk". On the other hand, their experiences were quite positive, and they found psychological treatments helpful when they participated in them.

Conclusion: Education for both patients and health professionals unfamiliar with psychological treatments for pain may improve access to these treatments.

Key Words: Chronic Pain; Patients' Experiences; Psychological Treatment; Singapore

Introduction

Chronic pain is a potentially debilitating condition that is known to impact significantly on a person's physical, emotional and social wellbeing (Gatchel et al., 2007). For people with chronic pain, medical diagnoses are often non-specific and inadequate in accounting for reported pain symptoms or pain impacts (Wall, 1979). Many people with chronic pain search for a pain cure but few achieve the level of pain reduction that they desire. As a result of the difficulties in achieving relief by conventional means, complex models of treatment that take into account psychological, social and medical factors have been developed (Gatchel et al., 2007; Wall, 1979; Morley, 2011; Mullersdorf et al., 2011). These approaches, however, are not equally developed in all parts of the world.

Psychological treatments form an important part of a complete approach to chronic pain. These treatments generally focus on lessening the impacts of chronic pain (Morley, 2011). Among these treatments, Cognitive Behavioural Therapy (CBT) for chronic pain is typically regarded as having a good evidence base (Hoffman et al., 2007). A recent Cochrane review found small to moderate effect sizes for CBT for managing chronic pain in adults (Williams et al., 2012). In this review, the strongest effect was shown for depression and catastrophic thinking, followed by disability and pain. Once again, psychological treatments are not uniformly available in all parts of the world.

Chronic Pain in a Cross-Cultural Context

Cultural differences in experiences of health problems, experiences of treatment, and in potential barriers in access to health care services have been shown in a number of studies (Lavernia et al., 2011; Merry et al., 2011). A comparison of blacks and whites seeking treatment for chronic pain in the

United States (US) showed that after controlling for pain severity, the black group reported more avoidance of activity, more fearful thinking and more physical symptoms (McCracken et al., 2001). Significant cultural differences were also found in self-care behaviours and preferences for components on a pain management program (Merry et al., 2011). This study was also conducted in the US. Clearly, cultural background can influence the ways we conceive illness and the ways we make healthcare decisions (Markus & Kitayama, 1991).

Qualitative studies conducted in western populations find that general adherence to treatment is influenced by patients' appraisals of it (Bishop et al., 2008; Bucks et al., 2009). Indeed patients in different cultural contexts encounter different healthcare experiences that may form the basis for these appraisals. A comparison of chronic pain patients from Puerto Rico and New England revealed that patients and healthcare providers from New England took a biomedical view of illness while those from Puerto Rico often addressed chronic pain as a biopsychosocial experience (Bates et al., 1997). In a qualitative study with older Korean women, chronic pain was embraced as part of the natural process of ageing rather than as a problem to be solved (Dickson & Kim, 2003).

Cross-cultural uniformity in patients' experiences and expectations with chronic pain cannot be assumed. Meeting a goal of worldwide effective healthcare delivery for chronic pain, within the environments where people with chronic pain live and function would seem to require an approach that takes into account patients' lived experiences across healthcare systems and in differing national contexts (Pillay et al., 2013).

In some areas of the world there is little pain research and less treatment development. At present, few studies from Southeast Asia examine the

treatment experiences of people with chronic pain. Examining the patient perspective, can add richness to our understanding of the treatment experience in non-western cultural contexts and lead to a better understanding of how to meet the needs for chronic pain treatment in these cultures for treatment development in the future.

The Case for Singapore

Singapore has a complex mix of Asian cultures, a mix of people of Chinese, Indian, Malay and Eurasian background, plus links with its British colonial past. Singapore's mix of cultures and unique history result in a multifaceted health care system, including both western medicine and differing Asian traditional approaches (Bishop, 1998). Hence, it is a potentially fruitful context for a study on perceptions, experiences, needs, and potential barriers in chronic pain treatment, including particularly psychological treatments, from the patients' perspective.

There are at present at least five studies focused on chronic pain treatment from Southeast Asia, and including psychological methods (Abdul Jalil et al., 2009; Cardoso et al., 2012; Elsegood & Wongpakaran, 2012; Lubis et al., 2013; Tan et al., 2009). However, these studies primarily looked at treatment outcome. In the present study we planned to examine, not treatment outcomes, but patients' experiences from within the healthcare system, their views, judgments, and needs, framed in their own words.

Qualitative methods that focus on people's perceptions, experiences and opinions are an appropriate choice of enquiry to understand and explore the richness of the treatment experience for chronic pain in Singapore, offering a perspective that can complement standard quantitative research approaches.

Study Aims

The broad aim of this qualitative study was to understand experiences of people seeking treatment for chronic pain in Singapore. Our primary aim was not to make cultural comparisons or test hypotheses of cultural differences in this respect. From this direct examination of patient experiences we planned to specifically explore (a) potential barriers to psychological treatment for chronic pain within the broader treatment experiences and expectations for people with chronic pain, and (b) factors that could help improve uptake of psychological treatment in a group of people with chronic pain. To our knowledge, this is the first study of this type in the Southeast Asian region.

Methods

This study was approved by the Domain Specific Review Board (DSRB: 2012/00717), the local ethics committee that governs and approves all research conducted within any healthcare setting in Singapore.

Design

We used an inductive, semi-structured, interview format to obtain in-depth and detailed information about participants' experiences regarding treatment for chronic pain and access to this treatment, in Singapore. These interviews included a specific emphasis on psychological treatments. All interviews were conducted in English as English is the pre-dominant first language spoken and understood in Singapore.

Participants

Participants were recruited through a multidisciplinary pain clinic at a local restructured (part public funded) hospital. Participants were invited to take part in the study after routine consultations with one of the health professionals (pain physician, nurse specialist, physiotherapist, or psychologist) on the pain team. We purposefully sampled participants with a variety of experiences of

psychological treatment. As we wanted to gather a variety of responses from people seeking treatment at the multidisciplinary pain clinic, and yet also capture those most likely to be referred for psychological services, we interviewed mainly people who had some experience with psychological treatment as well as others not receiving this type of treatment. It is relevant to sample a range of perspectives, although it was not our intention to equally represent different subpopulations.

Participants were recruited until data saturation was reached. Saturation is the point at which no new themes arise with the inclusion of additional interviews (Strauss & Corbin, 1998; Walker et al., 2006). This was achieved through the use of constant comparison and review of the data. Data saturation was reached at 15 participants. Participants were included if they were (a) suffering with chronic pain for more than 3 months, (b) English speaking, (c) between 21-65 years of age, (d) a Singapore citizen, and (e) able to complete the interview without difficulties. Participants were excluded if they were (a) suffering from a cognitive impairment or (b) suffering from a psychiatric condition that, in either case, prevented them from completing the interview.

Our final sample of participants included one who was only seeing the physiotherapist and pain physician and another who was recently referred to see a psychologist but had not started any treatment. Of the remainder, one was seeing a psychologist but not for pain management or psychological treatment per se, eight were on individual follow-up with the psychologist, and four had attended a CBT program. A total of three men and twelve women participated in the study. On average, participants who were on individual treatment were younger with a longer duration of pain suffering compared to participants in the CBT group and those who had no experience of

psychological treatment. Overall, eight participants were suffering with low back pain, four with fibromyalgia, two with neck pain and one diagnosed with Complex Regional Pain Syndrome. Eight participants were single, six were married and one was divorced. The mean years of education was 13.8 years (SD = 2.65). Six participants were in full time work, three were in part-time work, three were homemakers, one was unemployed, one had retired and one was a student. Table 1 provides a summary of participants' characteristics.

Table 1: Participant Characteristics

	Individual	CBT group	No Psychological Treatment
Total number in each group	8	4	3
Age (mean) (SD)	44.5 (10.99)	55 (5.48)	51 (1.73)
Gender (% female)	75	100	67
Years of pain suffering (mean) (SD)	8.69 (4.95)	4.38 (3.90)	3 (1.73)

Procedure

Recruitment was conducted by the lead author (S.Y.) and other health professionals at the pain management clinic. S.Y. was a practicing pain psychologist at the pain clinic where participants were recruited, although she had not been actively involved in direct treatment delivery for six months prior to or during the study. Participants who were invited to take part in the study were provided with an explanation of the study, given a study information sheet to

review, and were able to discuss their questions, prior to providing their consent. Participants who agreed to participate then provided their signed consent.

A quiet, sound proof clinic room at the pain clinic was used to conduct the interviews. The interviews were audio taped and S.Y. kept a reflective diary to record observations of each interview. Interviews lasted between 15 and 40 minutes (average 27.5 minutes). The interviews followed a semi-structured interview schedule (see Appendix for details) which comprised of open ended questions asking participants broadly about their experiences of seeking treatment for their condition in Singapore, their thoughts about psychological intervention for chronic pain, specifically about their thoughts on CBT as well as suggestions as to how to improve the uptake of psychological intervention for chronic pain treatment. All interviews were transcribed verbatim. Nvivo 10 software was used for data management.

Data Analysis

We conducted an inductive thematic analysis (Braun & Clarke, 2006) with elements of grounded theory (Glaser & Straus, 1967) and framework analysis (Ritchie & Spencer, 1994) followed in the coding process. First, S.Y. listened to the interviews, read and re-read the transcripts before coding the interview line by line. After the first five transcripts were coded, the codes and the transcripts were re-read, with codes that were most common and applicable to the research question applied to the next five transcripts. This same procedure of coding was then applied to the remaining five transcripts. A coding manual was created electronically allowing constant comparison and refinement between codes and transcripts to ensure that the codes were consistent and accurately reflected the data (Glaser & Straus, 1967). When new codes were

identified, the coding manual was updated and refined. The codes were checked by two co-authors (R.M.M. and A.B.). Codes that identified similar aspects of the data were classified together as main themes or subthemes. All authors discussed the interviews, code and themes, further refining the data analysis process. Emerging and new codes were applied to earlier transcripts to ensure that themes were grounded in the full set of data. Following the identification of the main themes and sub-themes obtained from the data and agreed by all authors, participants were classified according to their gender, age, occupation, diagnosis and the type of treatment they have experienced, including no experience of psychological intervention (NT), experience with individual sessions of psychological treatment (IT) and experience with a CBT-based group treatment (GT). The themes are presented in the following results section together with illustrative quotes that best represented the particular theme. All participants were given an ID number for purposes of confidentiality and anonymity and all identifiable data in the transcripts were removed.

Results

The results are presented according to themes and sub-themes [24]. There were a total of 3 main themes: “Expectations and Realities of Health Professionals”, “Personal Attitudes and Beliefs” and “Practical and Social Factors”. The theme and sub-theme labels and their categorisation are shown in Table 2. Participants demonstrated a clear understanding of the interview questions. However, Singaporeans often communicate in a unique style of English, and this sometimes appears in participant responses.

Table 2: Summary of Main Themes and Sub-Themes

Main Themes	Sub-Themes
Expectations and Realities of Health Professionals	Communication Style
	Communication Content
	Patients Treatment expectations of Health Professionals
Personal Attitudes and Beliefs	Beliefs about Treatment
	Expectations of cure
	The impact of pain on their lifestyle and their relationship to painful activities
	So why are we paying just to talk
Practical and Social Factors	Process of seeking treatment
	Social Support
	Practical Barriers
	Environmental Facilitators and Promotional Material

An examination of the data revealed that general treatment experiences and expectations of both patients who had experience of psychological treatment and those who had not were mostly similar. There was only a small sample of three participants who had no experience of psychological treatment. Presenting the data from these participants separately appeared unlikely to provide any added information. Hence, the results from both participants who had experience of psychological treatment and those who had not are combined.

Expectations and Realities of Health Professionals

Participants discussed their thoughts about the communication style of and content from health professionals as well as their treatment expectations of health professionals. Participants felt that having a doctor who demonstrated empathy and listened was most helpful in the treatment process.

Communication Style

“Doctor who is empathetic enough to listen”

Participants expressed their relief at finally finding a concerned and caring health professional to help them manage their pain condition. These health professionals were willing to take time to listen to the participants and this was appreciated.

“Finally I managed to have a doctor who is empathetic enough to listen instead of just prescribing and then sending me out of the door...” (Female, 52, GT)

A participant who experienced a lack of empathy in treatment said...

“...health professionals, do you understand? You don't understand what I mean when I say oh when I sit here I'm even talking to you I'm having this spasm...you don't get it because you don't have it!” (Female, 51, IT)

Communication Content

In the course of seeking treatment, health professionals explained treatment options. Participants felt that some health professionals encouraged them to take responsibility for their condition, whilst surgeons provided advice to participants who were keen on surgery. Participants who accepted a referral to the pain psychologist expressed that the health professional who referred them clearly explained to them that psychological intervention would help them manage their pain better. One particular participant mentioned he was told by

his surgeon that he “*would not guarantee that pain will be gone*” and that there were “*chances of getting paralysed*” (Male, 50, IT) from the operation. However, another participant reported that he was initially “*pushed to go for surgery*” (Male, 52, NT).

“*Why I accepted is because (name of doctor) did explain to me that coming over to the psychological side will help me to at least...help me to try and manage my pain so that I can have as normal a life as possible.*” (Female, 56, IT)

One participant however reported that “*Orthopaedic doctor told me this pain management is not for you it’s for people with unsound mind.*” (Female, 61, GT)

An empathetic health professional who communicated appropriate content to participants encouraged psychological treatment uptake.

Patients’ Treatment Expectations of Health Professionals

Participants expected health professionals to provide help and to promptly refer them for the right treatment. They described delays in obtaining diagnoses and treatment from some providers, felt frustration from this, and felt limited in their own lack of knowledge about their condition. One participant had to initiate her own referral to the pain management service.

“*...it took them a while to get the correct treatment or get the correct diagnosis...I was referred from one department to another...it’s very frustrating because you are the one who is enduring the pain... yet you do not know what you are suffering from...financially, emotionally everything it’s very taxing for the patient*” (Female, 49, NT)

Some participants felt that doctors should be open to consider other treatment avenues beyond just treating their pain as a physical condition and consider other avenues that could be more effective

“I think doctors would do a far better job if they...realise that...it is not just the physical body that we are dealing with.” (Male, 52, NT)

Personal Attitudes and Beliefs

Participants described their beliefs about pain treatment in general and the impact of pain on their lifestyle. In expressing their beliefs about psychological treatment, a majority of participants queried why they were “paying just to talk”.

Beliefs about Treatment

Some participants expressed an expectation of cure for their pain condition and a desire to avoid medicines *“at all costs unless absolutely necessary” (Female, 49, IT)*. They explained that it was an *“innate fear ...I am taking all these drugs it is bad for me” (Female, 58, GT)* and the side effects that put them off.

Expectations of Cure

Participants who expected a cure reported increasing frustration when they could not get rid of the pain completely even though they had sought help from different doctors.

“Increasing levels of frustration every time something would fail to...work as a complete cure, I think I was looking for a complete cure...which I now realise it’s not easy.” (Female, 51, IT)

Impact of Pain on their Lifestyle and their Relationship to Painful Activities

Participants clearly expressed their views about significant impacts of pain on daily life.

“...my daily lifestyle has to change to accommodate to the pain which is not what I wanted...I don’t want to let pain take over my lifestyle” (Female, 37, IT)

Some participants believed that they should rest and avoid activity when in pain.

“When the pain comes I always cannot focus, usually I feel like I’m a bit paralysed. Cannot do anything then I might as well go and lie down...So whenever I lie down it’s because the pain strikes. Then gradually because the pain always comes I always lie down.” (Male, 24, IT)

“So Why Are We Paying Just to Talk”

Many participants expressed that they could not see the relevance of psychological treatments for pain at the point of being referred.

“What can you do?...You can’t really diagnose their medical condition...by just talking and not really treating their conditions? No medications and what else? You can’t do anything...except just talking to them.” (Male, 50, IT)

“How come you refer me here? Are you saying that my pain is not real? You mean the pain is only in my head? But I do feel the pain! I would probably feel angry and say...What’s wrong with you guys?...there are signs and symptoms...how can you tell me that there’s no pain, no real pain?” (Male, 52, NT)

On the other hand, participants who had a prior understanding of CBT or a basic understanding of psychological treatment for pain were open to this form of treatment.

“...because I understand what cognitive behaviour is about a prior understanding of it...kind of was more acceptable, more receptive to this

treatment...and that pre-knowledge is something that gave me that push to come, to accept the treatment.” (Female, 52, GT)

Process of Seeking Treatment

Some participants felt that after undergoing treatment at the pain clinic they were “*generally able to manage better...even when the pain is coming I know...how to deal with it...*” and that they now understood that “*pain...is nothing so...life threatening so scary*” (Female, 61, GT).

Participants felt that psychological treatment was helpful in providing a different perspective to pain and they were able to learn how to manage their thoughts, feelings, and behaviour related to pain. However, “*if the person is in denial he or she won’t be able to accept so that is actually one big hurdle to any cognitive behavioural therapy.*” (Female, 52, GT).

“*...so far the CBT the program that...I gone through...I’m more than satisfied...I feel I am under very good hands and most importantly my pain is alleviated...I don’t feel so much of discomfort...I can do more things with my life because I am able to participate in more activities.*” (Female, 58, GT)

Practical and Social Factors

Social Support

Social support was discussed as both a facilitator and a barrier to treatment uptake. Social support here included perceived support from participants’ social network or family, friends, community, religious and government support. Participants spoke more about how peer support and government support can be helpful. Religion was also briefly mentioned but not considered a main source of support.

Interestingly, participants who experienced individual psychology sessions felt that a pain support group would be helpful especially if it included

success stories related from patients who had previously gone through psychological treatment.

“...all the patients who are actually going through the same thing...come together and share with each other...we can learn from each other and then share our own problems and challenges.” (Female, 37, IT)

Participants agreed that government support in terms of subsidies, use of “medisave” (non-cash payment) and health promotion for psychological treatment for chronic pain would facilitate take-up rate for such a treatment. Medisave (Ministry of Health, Singapore^b) is a national medical savings scheme in Singapore which helps individuals put aside part of their income into a special account that can be used to meet their personal or immediate family's hospitalisation, day surgery and certain outpatient expenses. Currently, only a small selected number of outpatient treatments can be covered by medisave; pain management is not one of the few.

Practical Barriers

The three main practical barriers to uptake of psychological treatment for chronic pain were identified as cost, time and access to appointments and resources. Participants mentioned that cost of medical treatment in Singapore in general is high. People would choose to pay for medication and for doctor visits rather than other forms of treatment, psychological treatment included.

“It's cheap yet, will I pay \$80 for it? Will I pay \$100-\$200 per session, no I will not. Unfortunately, the frame of mind is that ok I need to pay for my medicines, I need to pay to see the doctor yes but will I pay market rates for psychotherapy generally for chronic pain I would not.” (Female, 51, IT)

Some participants expressed little difficulty with gaining access while some felt that access could be improved. The barrier of time was mainly

expressed as an issue of time commitment to attending psychological treatment.

Environmental Facilitators and Promotional Material

Many participants felt that providing education to the public in the form of public talks, seminars, community outreach programs and published information could facilitate uptake of psychological treatments. They felt that specifically raising public awareness of the benefits of psychological treatment for chronic pain through printing and distributing flyers and brochures as well as the use of media and technological platforms, including smart phone technology, could also help.

“I suppose it is education...if they know that...the psychological and physical is related then I think they are more willing to try...educating them to what are the advantages of going for...this kind of treatment...” (Female, 56, IT)

Discussion

This study reports the experiences of fifteen people with chronic pain seeking treatment for their pain condition in Singapore. Key findings include the following: (a) an empathetic health professional who listened to patients and was knowledgeable in pain management as well as psychological treatments for chronic pain encouraged patients to accept a referral for psychological treatment, (b) a lack of knowledge of psychological treatments, high treatment costs and time required to attend treatment may be potential barriers to psychological treatment uptake, and (c) there may be benefits from educating patients and health professionals alike through talks, seminars, use of the media and technology, on the benefits of psychological treatment in the management of chronic pain. In general this study has identified that, from a patient perspective, the experiences of seeking treatment for chronic pain in

Singapore include positive and negative experiences, some delays, confusion, and frustrations, and at the same time, success and hope for a better future.

Considering that healthcare systems and treatment delivery in every country around the world are different, it is interesting that patients' experiences in seeking treatment in Europe and North America are similar to those from Singapore. Put simply, people want solutions, care, understanding, and clarity related to psychological treatments for chronic pain. These results must be understood in relation to the context and purpose of this study rather than just within a broad comparison to the wider available literature in this area.

Singapore is a unique country with strong western influences in education, the media, and in healthcare systems. Significant European and North American influences can be detected. For example, Singapore is the only country in Southeast Asia to adopt the English language as its primary language. Perhaps it is understandable that patients' experiences and expectations of healthcare are similar to those in the West, even if this was not expected.

Participants in our sample share in seemingly universal experiences of expecting cure, in wanting an explanation for their condition and for available treatment options (Dima et al., 2013; Paulson et al., 2001; Soderberg et al., 2002; Verbeek et al., 2004). They prefer an empathetic doctor who listens (Bradbury et al., 2013; Howarth et al., 2014; Jackson, 1992), clear information, a shared understanding with their health professionals about chronic pain, and prompt referral (Briggs et al., 2010; Kawi, 2014; Parsons et al., 2007; Petrie et al., 2005). Many participants in our study were upset and frustrated that the process of referral to see the "right" doctor was lengthy.

Health professionals who demonstrate abilities to listen, empathise, and explain chronic pain appear more likely to encourage patients to accept psychological treatment for this condition. The quality and type of interaction between health professional and patient is therefore important. Laerum and colleagues (2006) proposed that good client centred skills should include good listening skills, acknowledging patients' experiences that will empower the patient in treatment. Patient-centred care is recognised as a core value in patient-physician interaction (WHO, 2010). Health professionals who adopt this approach are able to foster an open communication with patients, and make patients feel that they are being taken seriously (Oosterhof et al., 2014) possibly leading to higher success for behaviour change.

Most qualitative studies in this area tend to examine patients' experiences with chronic pain treatment specific to medical or physiotherapy interventions, few studies have considered patients' experiences with psychological treatment. Participants here suggested that health professionals should look beyond just treating the pain problem as a physical condition.

In examining the views of participants who had no experience and participants who had experience of psychological treatment, we found that both groups of participants held similar treatment expectations in the referral and treatment process, and faced similar potential barriers to treatment uptake.

We identified three main barriers that could contribute to the low uptake of psychological treatment for chronic pain in Singapore. Firstly, health professionals treating chronic pain patients appeared to provide patients with conflicting opinions about the need for psychological treatment for chronic pain. Secondly, participants were skeptical that speaking with a psychologist could

help them with their pain. As such, they queried why they were “paying just to talk”. The high cost of medical treatment in Singapore was an added barrier.

From participants’ perspectives, there appeared to be a discrepancy in the advice that health professionals gave to patients with regard to surgical and medical intervention as well as advice on psychological treatment for pain. Some participants were given a balanced and realistic view of surgery while others were encouraged to go for surgery and were prescribed much medication. Differing expectations of patient and professional is a probable reason for poor treatment outcome and uptake of treatment (Verbeek et al., 2004).

Some participants understood pain to be a physical condition and felt that seeing a psychologist was not going to help their pain. Participants sometimes queried a referral to the psychologist thinking that health professionals did not believe their pain to be real and that pain was only in their head. Some participants appeared to adopt a predominantly biomedical model of treatment, expecting surgical, pharmacological or other interventions to be more suitable to treat their pain than just talking.

Studies in western populations find that patients who perceive that their pain is taken seriously and received an explanation that coincided with their own experiences, are more likely to accept an active role in managing their pain (Liddle et al., 2007; Matthias et al., 2012; Oosterhof et al., 2014; Peolsson et al., 2007). Similarly, as shown in our study, acceptance of the referral to see a psychologist was facilitated by a clear explanation of the usefulness of psychological intervention from the health professional treating them.

Participants’ experiences around psychological treatments for pain were by no means all negative. Participants who accepted and experienced

psychological treatment reported positive experiences. They found that the treatment provided them a different point of view with regard to their condition and facilitated their understanding of their pain condition. They became less intimidated by their pain and were able to learn how to manage their thoughts, feelings, and behaviour related to pain, and cope better with daily demands. One participant suggested that psychological treatment should be made mandatory at the pain clinic.

Practical issues such as high treatment costs, and therefore suggestions for more government support in the form of medisave, both reflect a common problem in fee-for-service systems, and a unique Singaporean solution.

Recommendations to Improve Current Services

One suggestion to improve the current services at the pain clinic was to initiate a pain support group. In particular, patients expressed that knowing they were not the only ones having pain, being able to interact with other patients and having a shared learning platform would help them to cope better with the stressors they faced within healthcare and in their daily lives. They felt that listening to success stories of past patients who have experienced psychological treatment would be helpful to encourage treatment uptake. However, we note that the evidence is mixed on the impact of pain support groups. While some studies show positive effects (Howell, 1994; Montgomerie, 1994; Subramaniam et al., 1999), such groups can also have either no effect or a negative impact on patients, through such processes as mutual reinforcement of the sick role, a sense of need and entitlement, or learned helplessness (Linton et al., 1997; Thieme et al., 2006). As such, careful design may be needed before initiating such support groups.

Another suggestion was for remote follow-up sessions in the form of an e-mail or phone call to improve communication and treatment results. Studies (Cooper et al., 2009; Lorig et al., 2002; Taylor et al., 2002) have shown that follow-up sessions can provide motivation and reassurance; with follow-up sessions delivered either by return visits, telephone calls or e-mails.

It was interesting that patients desired more peer support and government support as facilitators to treatment, rather than support from family or friends, as important in their recovery process. This finding contrasts other studies (Bremander et al., 2009; Sheffer et al., 2007; Turk & Rudy, 1988) that have found the inclusion of family support in patients' rehabilitation process to be important and beneficial. This finding is unexpected, considering that Singapore society as a whole is still regarded very much as a collectivist society, where family involvement is entrenched in an individual's life (Bishop, 1988).

Study Limitations

A major limitation in this study is that the interviewer was also a practicing pain psychologist at the pain clinic where participants were recruited. Although she was not providing treatment at the time of the research, out of the 15 participants recruited, she had prior involvement at least once with 10 participants, either as a primary treatment provider or to supervise a junior colleague who was providing treatment. As such, it was possible that the findings could have been partially influenced by interviewer or participant biases. Recordings in the reflective diary describing the interviews, however, showed that these participants appeared comfortable in the interviews and took an open and candid stance. Participants also appeared to share a balanced view of their experience, noting both positive and negative aspects. Follow-up

analyses of the individual transcripts did not reveal any clear difference in results between those with prior involvement with the interviewer and those without.

Our original intent was to include a wider mix of patients from different ethnic backgrounds to reflect the mix of cultures in Singapore. However, we struggled in this aspect. Our study included a majority of participants of Chinese descent. A check on the clinic data showed that the distribution of gender, race and age of the recruitment sample did reflect the general pool of patients seen at the pain clinic.

Adopting purposive sampling methodology and data triangulation, we intended to recruit participants who had no experience with psychological treatment, although admittedly, in practice, this resulted in a smaller number of participants with no previous experience of psychological services. We did not have a predetermined sample size as following the methodology of data saturation, recruitment stopped only when data saturation was reached, where recruiting another participant would not add new data to the existing data collected. Nonetheless, a limitation of our methods is that we likely did not include enough participants of one particular type, those appropriate for referral for psychological services but who refuse or otherwise do not follow-through.

We are also aware of general limitations of qualitative methodology. In particular, as the data were only collected from a few participants, it is not possible to generalise our findings to a larger population. Qualitative methods allow the researcher to step back and observe participants' experience with a minimum set of pre-ordained assumptions so that observations or potential patterns that could be missed are caught. At the same time these methods do not provide a basis describing the frequency of events on a population basis, for

estimating the magnitude of relations between events, or making statements of prediction or cause. These preliminary results may provide a guide for further research in this area.

Conclusion

Patients seeking treatment for chronic pain in Singapore reported both negative and positive experiences. To further improve their experience and promote better access, education for both patients and health professionals unfamiliar with psychological treatment for chronic pain may be necessary. Some lack of knowledge held by health professionals in diagnosing and understanding chronic pain conditions appear to leave them ineffective in informing and guiding patients through processes of referral to other services, including psychological treatments. Through psychological treatment, patients appear to view chronic pain from a different perspective, and were better able to manage their life challenges, their thoughts, feelings and behaviour in relation to pain. Such patients were “more than satisfied” with their treatment experience.

Acknowledgements

The authors wish to thank Dr Vincent Yeo (Director of the Pain Management Clinic at Tan Tock Seng Hospital), Sister Tina (Clinic Manager) and all the staff at the Pain Management Clinic for their support of this study.

Appendix

1. Tell me about your experiences of seeking treatment for your pain condition in Singapore?

[If needed prompt:

What are some of your thoughts about the current available treatment?]

2. Please describe some of the successes and challenges you have had in seeking treatment.

[If needed prompt:

How helpful is the treatment or treatments in helping you manage your pain?]

3. Have you been referred or received Cognitive Behavioural Therapy for your pain problem?

[If needed to explain] This sort of treatment is not “psychiatric”, and does not involve taking medicines. This type of treatment includes mainly training in skills to deal with pain.

[If no] Tell me what you would do or how would you react if you were referred to such a treatment for your pain condition?

[If needed, prompt with the following:

a) What might some of your thoughts be?

b) How would you feel?]

[If yes] Tell me some reasons why you chose to attend such a treatment?

[If needed, prompt with the following:

a) Do you think it helped in anyway?

b) Which part of treatment was most helpful and which part the least helpful?]

4. We would like to understand why some patients who suffer from chronic pain might accept psychological treatment for their condition and why others might not. In your opinion why do you think this is so?
5. Is there anything that could be done to improve the use of a psychology based service for chronic pain?
6. In order to make psychological treatments more accessible to chronic pain patients, we are interested to design a treatment that patients like you would be keen to attend. Some of our goals in designing the treatment would be to make sure patients use it and that it is affordable. We also want it to focus on helping you manage your pain more effectively, to function better in your daily life, and eventually reduce hospital or clinic visits. What do you feel such a treatment would need to include to achieve this?

[If needed prompt:

- a) How might we describe/advertise the service so that it would capture your interest?
- b) How do we make it affordable?
- c) Is there anything else you feel we would need to include when we design the treatment?]

Chapter 8: Healthcare Professionals' Perceptions of Psychological Treatment for Chronic Pain in Singapore: Challenges, Barriers and the Way Forward

8.1 Chapter Overview

Results of the qualitative study described in Chapter 7, highlight important issues regarding the role that health professionals play in patient experiences of and engagement with psychological treatment for chronic pain. In particular, empathetic healthcare professionals who listen, are knowledgeable and provide a clear explanation of the benefits of psychological treatment for chronic pain, and promptly refer patients for treatment, appear to have facilitated the uptake of psychological treatment.

The perceptions, attitudes and beliefs about psychological treatment held by pain physicians are likely to influence their management style during the doctor-patient consult (Fullen, Baxter, O'Donovan et al., 2008) and potentially, referral patterns for psychological treatment. In healthcare systems like the one in Singapore that follow a "top-down" approach in medical treatment, doctors are given the authority and predominant responsibility to make treatment decisions, including referral decisions for treatments offered by allied health professionals, such as psychologists. Treatment recommendations of other healthcare professionals in multidisciplinary pain management settings, such as nurses, physiotherapists and occupational therapists can also have an influence on the referral process, but to a lesser degree. With regards to access and quality of engagement, it appears that healthcare professionals' perceptions of

psychological treatment for chronic pain is similarly equally important as patients' perceptions of this treatment.

The main aim of this study was to gain an insight into the perceptions of psychological treatment for chronic pain from the viewpoint of healthcare professionals providing treatment for this condition in Singapore. Similar to the study examining patients' perceptions of psychological treatment, a qualitative approach was also adopted here.

This is a first qualitative study in the area of chronic pain that has focused on healthcare professionals' views and conducted in Southeast Asia. Identifying prevailing healthcare professional practices, important treatment barriers, and factors that can facilitate psychological treatment for chronic pain in this context is expected to contribute to improved understanding and to the development of better systems to support high quality, accessible, and efficient delivery of psychological treatment for chronic pain in Singapore.

An article based on this study has been published, "Yang, S.Y., Bogosian, A., Moss-Morris, R., McCracken, L. M. (2016). Health professionals' perceptions of psychological treatment for chronic pain in Singapore: Challenges, barriers and the way forward. *Disabil Rehabil*, 38(17), 1643-1651.". The accepted version is presented here. Citations in the submitted papers have been converted to APA 6th style and included in the references section.

Participant informed consent for this study is included in Appendix A and the final version of the coding manual included in Appendix C.

Healthcare Professionals' Perceptions of Psychological Treatment for Chronic
Pain in Singapore: Challenges, Barriers and the Way Forward

Su-Yin Yang^{1, 2}, Angeliki Bogosian³, Rona Moss-Morris¹, & Lance M. McCracken¹

¹. King's College London, Health Psychology Section, Psychology Department, Institute of Psychiatry, London, United Kingdom

². Pain Management Clinic, Tan Tock Seng Hospital, Singapore

³. City University, School of Arts and Social Sciences, Department of Psychology, London, United Kingdom

Correspondence to:

Lance M. McCracken, Professor of Behavioural Medicine, Health Psychology Section, Psychology Department; Institute of Psychiatry, Psychology and Neuroscience; King's College London, 5th Floor Bermondsey Wing, Guy's Campus, London SE1 9RT.

Phone: +44 (0)207 188 5410

Fax: +44 (0)207 188 0184

E-Mail: lance.mccracken@kcl.ac.uk

Keywords: Qualitative; thematic analysis; semi-structured interviews; multidisciplinary; treatment experiences; outpatients.

Implications for Rehabilitation

Chronic Pain Management

- A multifaceted approach is required to reduce barriers to psychological treatment for chronic pain in settings like Singapore.
- Educating healthcare professionals on the need for a multidisciplinary approach to chronic pain could help in reducing misconceptions and increase understanding of the benefits of psychological approaches.
- Utilising both media and technological platforms as a means to facilitate psychological treatment uptake for chronic pain may be a way forward for a technological savvy generation.

Abstract

Purpose: There are very few studies on healthcare providers' experiences of delivering treatment for chronic pain in a Southeast Asian setting. The aims of this study are to understand the experiences of professionals delivering treatment for people with chronic pain in Singapore and identify possible barriers to psychological treatment for this condition within the broader experiences of these professionals.

Method: Healthcare professionals with at least one year experience treating chronic pain were recruited and purposefully sampled. Fifteen inductive semi-structured interviews were conducted to explore healthcare professionals' experiences of treating people with chronic pain. Interviews were transcribed verbatim and analysed using thematic analysis.

Results: Four main themes were identified: 'System Barriers', 'Core Beliefs and management of Chronic Pain', 'Engaging Patients in treatment', and 'Creating Awareness for Chronic Pain Management.' Professionals trained in a multidisciplinary approach to pain management were seen as rare. Professionals who could refer patients for psychological treatment do not refer due to costs, and their perception that patients may lack understanding of such a treatment.

Conclusion: Reducing barriers in the access to psychological treatment in settings like Singapore will require a multifaceted approach.

Introduction

Healthcare professionals quite naturally can exert significant influence on the treatment experience of people with chronic pain. Healthcare professionals' clinical choices, methods, and delivery style are influenced by their past experiences, education, knowledge of evidence, and personal beliefs (Harldorsen et al., 1996; Linton et al., 2002). Patient-related and policy-related factors specific to the health service, including influences of the medico-legal system, also can contribute to the way patients are treated during the medical consult (Espeland & Baerheim, 2003; Fullen, Baxter, O'Donovan et al., 2008; Schers et al., 2001).

Studies from North America have shown that limitations in knowledge and skills related to pain management among clinicians could be a contributing factor to inadequate pain management (Drayer et al., 1999; Fishbain et al., 2000). For example, it appears that patients are not referred to multidisciplinary pain treatment because their doctors are either not aware of its availability or do not believe it is effective (Fishbain et al., 2000).

Psychological Treatments for Chronic Pain

Research consistently demonstrates the efficacy of psychological treatments for chronic pain (Eccleston et al., 2002; Morley et al., 1999; Turk, 1996). In particular, treatments based on cognitive-behavioural therapy (CBT), perhaps the most often applied psychological treatment model, appear efficacious for chronic pain (Eccleston et al., 2009; Williams et al., 2012). At least in Europe and North America, the multidisciplinary pain management approach, based on a biopsychosocial model and including CBT, has been widely recommended as a standard chronic pain management treatment approach (National Pain Summit Initiative, 2010; Pain Proposal, 2010). This

approach is less common in Southeast Asia (Kitahara et al., 2006; Tan et al., 2009).

Bridging the Gap

There are few studies detailing the experiences of healthcare professionals in the treatment of chronic pain in the wider Southeast Asian population. Similarly, there are few if any that address current views of psychological treatments for chronic pain, and any factors that may affect access to these treatments. A recent systematic review found a total of 17 psychological treatment outcome studies focused on chronic pain in East and Southeast Asia, a majority of these studies only published in the last ten years (Yang et al., 2016a). It appears, however, that there are no studies from Southeast Asia detailing the experiences of healthcare professionals with regard to these treatments. Singapore's complex mix of four separate cultures, Chinese, Indian, Malay and Eurasian, results in a unique context for healthcare delivery, a context that is both distinctive and may also inform a general perspective on the health of the wider Southeast Asian population.

The purpose of the current study is to examine health care provider experiences of psychological treatments for chronic pain in Singapore. The use of qualitative methodology in this study is an appropriate choice to explore the opinions, perceptions and experiences of various healthcare professionals and their interaction with psychological treatments for chronic pain in this context. Given the lack of previous research, this study aimed to include in-depth exploratory qualitative analysis of the experiences of those who provide treatment for people with chronic pain in Singapore as a way to support potential improvements in patient care.

Methods

This study was approved by the Domain Specific Review Board DSRB: 2012/00717 in Singapore. All participants provided written informed consent to participate in this study.

Design

An inductive semi-structured interview format was used to obtain in-depth and detailed information about healthcare professionals' experiences of providing treatment for people with chronic pain in Singapore, as well as their thoughts on referring people with chronic pain for psychological treatment. All interviews were conducted in English. The unique style of English in which Singaporeans communicate in is reflected in the healthcare professionals' quotes.

Participants

Healthcare professionals, who have had at least one year's experience treating chronic pain in Singapore, were recruited via an e-mail invitation through the membership list of the Pain Association of Singapore (PAS) as well as directly through local hospital pain clinics, including partially government funded and privately funded clinics, in Singapore. Participants were excluded if they did not have experience treating patients at outpatient clinics. As we wanted to gather a variety of responses, in addition to the e-mail invitations we directly invited a group of healthcare professionals with different training backgrounds. This included the types of professionals that usually provide treatment for pain whether in multidisciplinary or unidisciplinary settings. We interviewed medical professionals, allied health professionals and non-conventional treatment providers. Recruitment of participants proceeded until data saturation was reached through the use of constant comparison and review of the data. Data saturation is the point where including additional

interviews did not result in the creation of new themes (Strauss & Corbin, 1998; Walker et al., 2006). Data saturation was reached at 15 participants. All participants who were approached agreed to participate.

Our final sample of participants (N = 15) included five pain physicians, three pain nurses, one psychologist, three physiotherapists, two occupational therapists, and one osteopath who are currently and predominantly working with patients with chronic pain. All participants had at least basic knowledge of the use of psychological treatment for people with chronic pain. A total of eight men and seven women participated in the study. The participants' median age was 40 years (range 27-56) with a median of 8 years (range 1.5-15) of working with people with chronic pain. Table 1 provides a summary of the participant characteristics.

Table 1: Participant Characteristics

	Pain Physician	Pain Nurse	Psych	PT	OT	Osteopath
Total number in each group	5	3	1	3	2	1
Median age (range as relevant)	40 (39-51)	41 (38-56)	30	36 (33-37)	36 (27-45)	42
Gender Ratio	Male: 5 Female: 0	Male: 0 Female: 3	Male: 1 Female: 0	Male: 0 Female: 3	Male: 1 Female: 1	Male: 1 Female: 0
Number of participants per type of practice	PP: 2 PGF: 3	PP: 0 PGF: 3	PP: 0 PGF: 1	PP: 1 PGF: 2	PP: 1 PGF: 1	PP: 1 PGF: 0
Median years of practice (range as relevant)	8 (5.5-10)	9 (7-10)	1.5	7 (3-15)	6 (2-10)	10

Psych, Psychologist; PT, Physiotherapist; OT, Occupational Therapist; PP, Private practice; PGF, Partially government funded

Procedure

Healthcare professionals who agreed to participate were interviewed in a private room at their workplace. The primary researcher (S.Y.) explained the study to each participant separately and also provided a study information sheet for participants to review prior to signing the informed consent form. Participants who agreed to participate were then given a consent form to sign. All interviews were audiotaped and the researcher kept a reflective diary to record observations and impressions from each of the interviews. The interviews

followed a prepared interview schedule (see Appendix A for details) that comprised of open ended questions and lasted between 10 and 40 minutes (average 22.51 minutes). Participants were broadly asked about their experiences of treating chronic pain patients in Singapore, their thoughts about psychological treatments for chronic pain and referring patients for such a treatment. Participants were also asked to suggest ways to improve the uptake of these treatments. All interviews were fully transcribed. Nvivo 10 software was used for data management.

Data Analysis

Data analyses included both inductive thematic analysis (Braun & Clarke, 2006) and features of grounded theory (Glaser & Strauss, 1967). Framework analysis (Ritchie & Spencer, 1994) was used in the coding process. The method of constant comparison used in framework analysis was adopted in the coding procedure, where S.Y. first listened to the interviews and coded the transcripts line by line. The first five transcripts were coded and codes that were most common and applicable to the research question were then applied to the next five transcripts and subsequently to the remaining five transcripts. To ensure that the codes identified were both consistent and reflected the true nature of the data, a coding manual was created allowing for constant comparison and refinement between codes (Glaser & Strauss, 1967). The coding manual was refined and updated each time new codes were identified. To ensure that themes were grounded in the complete data set, all new codes were applied to earlier transcripts and codes checked by two co-authors (A.B. and R.M.M.). Main themes and subthemes were formed from the classification of codes which identified similar characteristics of the data. After a thorough discussion of the interviews, codes and themes, all authors came to an

agreement on the final set of themes and subthemes that accurately reflected the data. Participants were subsequently classified according to their professional background, gender, age and the type of service they worked for (private practice or partially government funded hospital). The code of 'P' was given to physicians, 'N' to nurses, 'PT' to physiotherapists and 'OT' to occupational therapists. The code of 'PP' was given to those who were in private practice and 'PGF' given to those who were working in partially government funded hospitals. All participants were given a participant number for purposes of confidentiality and anonymity with all identifiable data in the transcripts removed.

Results

There were a total of four main themes of "System Barriers", "Core Beliefs and management of Chronic Pain", "Engaging Patients in Treatment" and "Creating Awareness among Health Professionals". The theme and subtheme labels and their categorisation are shown in Table 2 and described in turn.

Table 2: Summary of Main Themes and Sub-Themes

Main Themes	Sub-Themes
System Barriers	Challenges to get a group of people who are interested in chronic pain management Top down approach, takes a long time to change things. Lack of resources Lacking a biopsychosocial approach
Core beliefs and management of chronic pain	Health professionals perception of patients perception of pain
Engaging patients in treatment	Close and therapeutic relationship needed Educate patients on the benefits of psychological treatment Importance of involving the family
Creating awareness for chronic pain management.	Endorsement from health professionals Endorsement through patient experience Use of media and technology

System Barriers

“Challenges to get a group of people who are interested in chronic pain management”

A major challenge expressed by participants, was finding a group of like-minded professionals who were interested in chronic pain management. Many of those interviewed felt that the current training, for both medical and allied

health professions, is to blame for the lack of knowledge in pain management. With regards to the specialist area of psychological treatment for chronic pain, *“within the group of psychologists that are available...there are very few of them who are interested in chronic pain and managing patients with chronic pain.”* (P3, male, 40, PGF)

“Top down approach takes a long time to change things”

Participants expressed that the *“current healthcare system in Singapore it’s...hierarchical.”* (P3, male, 40, PGF), and pain management services have been given a low priority by higher management.

“(the) hospital is not very supportive in terms of...setting up of a pain management service or centre...because they say...that is not really very important.” (N2, female, 38, PGF)

With this perceived status of pain management in Singapore, many participants felt that challenges within the healthcare system were major barriers to more effective pain management with *“the awareness of chronic pain treatment itself... to be improved amongst hospital practitioners.”* (P5, male, 51, PGF). In comparison to other pain management facilities overseas, participants generally felt that *“locally we are not doing as much as some of the overseas setting”* (PT 1, female, 36, PGF)

Lack of Resources

A lack of resources including areas of funding, particularly considering the evidence base for psychological treatments, was further cited by participants as a potential barrier to effective chronic pain management in Singapore. Most of the participants, apart from one, felt that high treatment costs from a lack of medical funding deter patients from attending psychological

treatment sessions. Such costs also appeared as a deterrent for participants referring patients to see a psychologist for pain management.

“In terms of healthcare funding I’m a firm believer that more can be done. That the current levels of funding are not sufficient and we have a significant number of patients who cannot afford their treatments because of funding issues...I mean it applies to psychotherapy but it also applies to medication costs or even acupuncture.” (P3, male, 40, PGF)

Although participants believed that patients would benefit from an intensive group based CBT, they were cautious in referring patients for this treatment due to treatment costs.

“In Singapore I think is the cost of it, because we tried to organise you know the CBT...when the costing came...up to a thousand (\$) for group therapy you know per person. In Singapore it’s not really very possible...in the patients that I have broached the subject to...you know they find that the cost is too hefty for them to bear...for patients to come up with cash up front maybe they will not be so keen...” (P1, male, 39, PP)

Participants felt that obtaining the government’s approval for the use of medisave (medical savings scheme) (Ministry of Health, Singapore^b) for treatment of chronic pain would be helpful. With medisave, individuals who require medical services in Singapore can utilise this special account to pay for their personal or immediate family’s hospitalisation, day surgery and certain outpatient expenses. Medisave does not currently cover the costs of outpatient chronic pain treatment. Participants felt that medical subsidies for pain treatment would help patients who could not afford treatment, allowing them to receive the treatment they need and not just the treatment they could afford.

“at the moment they are allowing medisave to be deducted for chronic cases like diabetes and all that right?...Ministry of Health needs to acknowledge that pain is as chronic as... diabetes as chronic kidney disease...If that happens then people will come forward (for treatment). (OT 1, male, 45, PP)

Lack of Psychologists

Apart from funding issues and treatment costs, participants felt that a shortage of appropriately trained psychologists specialising in chronic pain management is another major barrier. In addition, some participants believed that it is not a simple lack of personnel trained in psychology that is a problem but psychologists lacking pain management skills partly due to a lack of appropriate, specific, professional training.

“We do have psychologists who can help us...they do have some experience...but they are not very well trained in terms of chronic pain management.” (N2, female, 38, PGF)

Participants suggested that one of the ways to manage this lack of psychological resource was to train advanced practice nurses or other allied health professionals in basic psychological methods.

Lacking a Biopsychosocial Approach

In terms of the broad approach to chronic pain management, participants felt that healthcare professionals *“tend to adopt a very medical model rather than looking at the... biopsychosocial model.” (P5, male, 51, PGF)*. Participants felt that many of their counterparts are unlikely to refer patients for psychological treatment *because they don’t know much about psychotherapy or what psychologists do.” (N3, female, 41, PGF)*

“I belong to the old MBBS structure (Bachelor of Medicine, Bachelor of Surgery) where...the amount of psychology we are exposed is very minimal....

Most of the psychology I picked up later when I was doing pain exam. So in the undergraduate years you get very little psychology so you don't actually know what the psychologist actually do...the benefit of psychology therapy...not very well understood across the board. So people don't really know what is beneficial...unless they are blatantly quite mad...most of the time we don't think of referring to psychology...they obviously looks very anxious...they have some very strange way of thinking so it's obviously out of norm...maybe this one will benefit from psychology.” (P2, male, 40, PGF)

“I think most of the physicians treating pain still treat it as a one dimensional sort of disease...they don't realise that the patient that comes to see you for pain problems actually have a multitude of problems and that can also be psychosocial...with the increasing clinical workload and administrative of all the doctors it is very hard for a physician to actually explore the psychosocial make-up of the patient...” (P1, male, 39, PP)

Many of the participants expressed that building public awareness of what a psychologist can do for people suffering with chronic pain and educating all health professionals on the need for a multidisciplinary approach to chronic pain could help in reducing misconceptions and increase understanding of the benefits of psychological intervention.

Core Beliefs and Management of Chronic Pain

Many participants felt that it was difficult to work within the chronic pain field as they *“have to deal with...mistaken beliefs...from both patients and fellow healthcare professionals about how chronic pain is viewed and how it should be managed.” (P3, male, 40, PGF)*. Some participants felt that *“some of the specialists haven't really kept up to date perhaps...they think their approach is best that's why they do it.” (Osteopath, male, 42, PP)*.

Participants suggested that all *“healthcare professionals involved in the care of the patients would do well to learn about...the various psychological constructs...or problems that may...manifest in a chronic pain patient and therefore be able to identify and then follow up with a referral for treatment.”* (P3, male, 40, PGF)

Many participants expressed that they chose not to refer patients as they felt that patients were not ready to be referred for psychological treatment.

“if you bring up too early...people think that you think there is no other treatment for them and they think that you think that they are a bit crazy or mad...people who don't really like a lot of medicine they... believe that their body has ability to recover on their own...physical therapy and psychological therapy works very well for them...they tend to...be more motivated and... practice what you teach them.” (P2, male, 40, PGF)

Health Professionals' Perception of Patients' Perception of pain

Participants had their own perhaps pre-conceived ideas about patients' perception of pain. They felt that patients often displayed a cure seeking behaviour; had fixed beliefs about pain, and *“If you talk about psychological therapy, they either think you are accusing them of psychological problems or that they are imagining the pain”* (P2, male, 40, PGF)

“For some patients...to manage the chronic pain for life is not within their belief...it is a very big challenge trying to work with this group of patients, they may appear resistant...They want a cure they are hoping we can do something to help them take away the pain.” (Psychologist, male, 30, PGF)

Participants believed that among people with chronic pain, it is likely that many would have a misconception about psychological intervention for a chronic pain problem, and would tend to be concerned about being referred to

see a psychologist. This was highlighted as a major barrier for healthcare professionals referring to such a service, having to deal with such resistance from patients.

“Most of these patients that I see...feel there is a stigma, are you referring that I am depressed, I’m a xiao (mad) you know? So...the moment we...talk about...referring you to a psychologist or a psychiatrist, from that instance they tend to be a little bit worried.” (N3, female, 41, PGF)

Engaging Patients in Treatment

In terms of being able to engage patients in treatment, participants felt that the most important way to engage patients in treatment was to develop a close and therapeutic relationship with patients. Educating patients on the benefits of psychological therapy for pain and involving the patients’ family as a form of support for patients during the treatment process are also important components in engaging patients in treatment. A hindrance to such efforts would be patients holding onto a biomedical model and other challenging beliefs in the process of treatment.

“Besides pharmacology, to be successful in treating this group you definitely need...a very close and therapeutic relationship...before they open up themselves to you and willing to learn and listen to you.” (N3, female, 41, PGF)

“Education is one...anything that you would like people to know and support... first of all you need to tell them, educate them what it is, how it works and what is the benefit?” (N2, female, 38, PGR)

Creating Awareness for Chronic Pain Management

Participants suggested that endorsement of psychological treatment for chronic pain through mutual sharing at journal clubs, seminars, and conferences including experts from overseas to share their experiences, would

be helpful to publicise treatment to healthcare professionals. Suggestions were also made to make educational material more accessible to patients, communicate success of psychological treatment through 'word of mouth' and to utilise the media and technological platforms; with use of regular e-mail announcements, audio and video recordings, iPhone applications, engagement of social media, like Facebook, and creating online treatment to facilitate treatment uptake.

Discussion

Based on the findings from the current study, from participants' perspectives, chronic pain treatment in Singapore is predominantly restricted by system barriers that are currently in place within healthcare. Participants felt that their exposure to mainly a biomedical approach during their training and limited exposure to psychological treatments has resulted in a lack of a multidisciplinary treatment approach to chronic pain. Lack of resources in funding chronic pain treatment, leading to high treatment costs, and a lack of psychologists interested in managing chronic pain has also contributed to a low profile for psychological treatments in this area and a lack of awareness among professionals about the effectiveness of these treatments. From participants' views, patients and other healthcare professionals continue to have a stereotypical understanding that psychological treatment is only suitable for people who have clear mental health problems. These numerous barriers appear to contribute to low referral rates and ultimately limited access to psychological treatment for chronic pain. To the best of our knowledge, our findings contribute to the first qualitative study of healthcare professionals in the area of chronic pain conducted in Singapore and Southeast Asia.

In this study, it is interesting that healthcare professionals who seemingly support the biopsychosocial model of pain management chose instead not to refer patients for psychological treatment. Participants perceived numerous barriers on the part of patients in treatment: treatment cost and affordability, an emphasis on seeking a cure, fixed beliefs about pain and a perception that patients will feel they are being accused of imagining the pain. With these presumptions in place, many of these health professionals often chose not to explore this treatment option with patients. In the words of one participant, he was surprised that his patients were receptive to a referral for psychological treatment as he thought that patients would reject such a suggestion. In the end it appears that healthcare providers are presuming patient resistance or disinterest before checking to see if this is indeed the case – this represents a significant and seemingly unnecessary barrier to access.

In many ways, our findings are similar to findings from Europe. In particular, similarities in healthcare professionals adopting a biomedical model over a psychosocial model in treatment (Valjakka et al., 2013), healthcare professionals needing specialist training to assess and treat psychosocial issues related to chronic pain (Breen et al., 2007; Corbett et al., 2009), and a lack of resources for chronic pain treatment (Fullen, Doody, Baxter et al., 2008). Considering the pre-dominant western influences in many aspects of the healthcare system and in Singapore society as a whole, perhaps, these similarities are not so surprising.

The current healthcare system in Singapore including the curriculum for trainee doctors appears to emphasise a biomedical model of treatment. Studies examining the influence of treatment delivery from a biomedical model have predominantly been conducted with patients with chronic low back pain with

limited data on patients with general chronic pain. Specifically, a biomedical style of undergraduate training was shown to be associated with increasing negative beliefs and attitudes about low back pain (Cherkin et al., 1995; Linton et al., 2002). Delivering treatment from a biomedical model can lead healthcare professionals to unwittingly play a part in adding to patient disability arising from chronic low back pain, by heightened attention to disease or limiting the level of their daily activities (Linton et al., 2002; , Rainville et al., 2000). Earlier studies have shown that the attitudes and beliefs held by nurses were more important than their knowledge of particular aspects of care and treatment (Godin et al., 2000; Heath & Reid-Finlay, 1998). Such beliefs and attitudes held by health professionals about pain and disability are likely to influence the treatment recommendations that they provide to patients (Domenech et al., 2011; Ferreira et al., 2004; Houben et al., 2004) and patients' pain related behaviours and pain coping strategies (Daykin & Richardson, 2004; Linton et al., 2002; Williams & Keefe, 1991), such as in the context of low back pain. Considering that a high incidence of chronic pain complaints stem from the suffering of low back pain, these results may one day be replicated in a wider range of conditions.

Patients with chronic pain want an empathic and expert practitioner who can deliver a suitable treatment for them or refer them elsewhere (Dima et al., 2013). Medical consultations that involve good communication between the physician and patient and involve the patient in treatment are likely to result in better treatment adherence (De Haes & Bensing, 2009). These issues emphasise the importance of assessing patients' perceptions and feelings and tailoring treatment information to fit their needs.

Building public awareness of psychological treatments for pain may further help in reducing misconceptions and increase understanding of the

benefits of psychological treatment. The use of technological advancements has been suggested as a means to promote psychological treatment for pain. This has not been done for chronic pain management in Singapore. A recent systematic review of internet interventions for pain concluded that CBT-based internet programs showed an improvement in pain, activity limitation and costs associated with treatment, with less consistency shown for effects on depression and anxiety (Bender et al., 2011). Internet based interventions are still developing, but they appear to hold promise for pain treatment in the future (Eccleston et al., 2014).

Study Limitations

Following the methodology of data saturation, recruitment stopped only when data saturation was reached. Data saturation is the point where recruiting one more participant would not contribute new data to the existing data collected. Nonetheless, a limitation of our methods is the possibility that important views were missed.

Secondly, the primary researcher also sits as a council member on the PAS, which is a small organisation in a small community. This status could have also influenced the participants who volunteered for this study by virtue of association. Five of the healthcare professionals who participated in this study are members of the PAS. A review of the primary researcher's reflective diary however revealed that these participants appeared equally forthcoming and presented a balanced view in their responses. Both positive and negative views on the status of psychological intervention for chronic pain in Singapore were offered.

Questions in the semi-structured interview were kept as open as possible. However it is possible that some of the prompts could have led or influenced responses for participants.

Although qualitative methodology appears to have been an appropriate form of enquiry for this study, we also recognise the general limitations of this methodology. Qualitative methodology does not provide a basis for illustrating the occurrence of events on a wider population basis nor can causal inferences be made from the data. As our data were collected from only one city in Southeast Asia, generalisation to other populations and regions, such as other areas in Asia, is unclear and will need more study.

Conclusion

Overall our findings expand our general understanding of barriers to psychological treatment for chronic pain by providing us some insights into healthcare professionals' perceptions and experiences in Singapore. Ironically, healthcare professionals who seemingly support psychological treatment for chronic pain appeared to contribute to these barriers to treatment access and to further treatment development. Findings regarding barriers to psychological treatment from our study are similar in many ways to results from qualitative studies conducted in Europe. These barriers wherever they occur may have a kind of self-perpetuating quality, where a lack of knowledge, awareness, resources, utilisation, and local evidence, each feed into each other, in a cycle of misconception and failed engagement.

If the results found here are later verified in further research, they imply that improving access to appropriate treatment in settings like Singapore will require a multifaceted approach. This is likely to include policy initiatives, funding arrangements, changes within the structure of education and training,

dissemination of research findings, greater collaboration between service providers and service users, and significant service developments that are both sensitive to general attitudinal barriers and some that may be unique to Southeast Asia.

Acknowledgements

The authors would like to thank Dr Vincent Yeo (Director, Pain Management Clinic), Dr Ho Kok Yuen (President, Pain Association of Singapore), Ms Jane Chong (Operations Manager, Pain Management Clinic) and Ms Tina Png (Clinic Manager, Pain Management Clinic) for their support of this study.

Declaration of Interest

The authors report no declarations of interest.

Appendix A

Interview Questions

1. Tell me about your experiences of treating chronic pain sufferers in Singapore?
[If needed prompt with the following:
 - a) What are some of your thoughts about the current available treatment?
 - b) Please describe some of the successes and challenges you have had in providing treatment for patients.
 - c) How helpful is the treatment or treatments in helping patients manage pain effectively?]
2. What are your views on referring patients to a treatment with a focus on Cognitive Behavioural Therapy (CBT) to manage their pain problem?
[If needed, prompt with the following:
 - a) Tell me some of your thoughts and feelings on treatment that focuses on teaching patients to change patterns of behaviour to manage their pain problem.
 - b) How effective do you think this sort of treatment will be in helping patients function better with pain?]
3. We would like to understand why some healthcare professionals might be accepting of psychological treatment as a treatment for chronic pain and why others might not. In your opinion why do you think this is so?
4. Is there anything that could be done to facilitate the use of a psychologically based service for chronic pain?
5. In order to make psychological treatments more accessible to chronic pain patients, we are interested to design a treatment that professionals

like you would be keen to use as a service for your patients. Some of our goals in designing this service would be to make sure it is used and that it is affordable. We would also want it to focus on helping patients manage their pain more effectively, to function better in their daily life, and eventually reduce hospital/clinic visits. What do you feel such a treatment would need to include to achieve this?

[If needed prompt:

- a) How might we label or describe the service so that it would capture your interest?
- b) How do we make it affordable?
- c) Is there anything else you feel we would need to incorporate?]

Chapter 9: Psychological Treatment Needs for Chronic Pain in Singapore and the Relevance of the Psychological Flexibility Model

9.1 Chapter Overview

As already mentioned in Chapter 4 and Chapter 5, evidence for the processes of psychological flexibility (PF) and ACT for chronic pain remain limited in Asia. This chapter describes a cross-sectional study which (a) assessed the psychological treatment needs and treatment delivery preferences in a group of current users and non-users of conventional health services for chronic pain in Singapore, and (b) examined the potential relevance of the psychological flexibility (PF) model through an investigation of PF and related pain-outcomes as measured in this same group.

An article based on this study has been published, “Yang, S.Y., McCracken, L.M., Moss-Morris, R. (2016). Psychological treatment needs for chronic pain in Singapore and the relevance of the psychological flexibility model. *Pain Med.* <http://dx.doi.org/10.1093/pm/pnw175>.”. The accepted version with minor amendments is presented here. Citations in the paper have been converted to APA 6th style and included in the references section. Participant informed consent for this study is included in Appendix A, a sample of the participant study invite included in Appendix D and a sample of the validated questionnaires included in Appendix E.

Psychological Treatment Needs for Chronic Pain in Singapore and the
Relevance of the Psychological Flexibility Model

Su-Yin Yang^{1,2} (MSc Health Psychology) , Lance M. McCracken¹ (PhD Clinical Psychology) & Rona Moss-Morris¹ (PhD Health Psychology)

¹King's College London, Health Psychology Section, Psychology Department,
London, United Kingdom

²Pain Management Clinic, Tan Tock Seng Hospital, Singapore

Correspondence to:

Lance M. McCracken, Professor of Behavioural Medicine
Health Psychology Section, Psychology Department
Institute of Psychiatry, Psychology and Neuroscience
King's College London

5th Floor Bermondsey Wing, Guy's Campus, London SE1 9RT.

Phone: +44 (0)207 188 5410

Fax: +44 (0)207 188 0184

E-Mail: lance.mccracken@kcl.ac.uk

Disclosure: The authors declare that they have no conflicts of interest related to this study.

Abstract

Objective: The goals of the present study were (a) to assess the psychological treatment needs and treatment delivery preferences in people attending services or contacting a hospital website for chronic pain in Singapore, and (b) to explore potential relevance of the psychological flexibility (PF) model for this group by investigating associations between PF and pain-related outcomes.

Design and Setting: This was a cross-sectional questionnaire study of people with chronic pain in Singapore.

Subjects: Current users of treatment services at a tertiary pain management clinic (PMC), users of pain treatment services elsewhere, and non-treatment users.

Methods: Participants were either recruited face-to-face at a pain clinic or via an online portal. All participants completed a questionnaire, including a survey of treatment barriers and needs, treatment delivery preferences for chronic pain, and standardised measures of PF, pain interference, emotional functioning and healthcare use.

Results: A total of 200 participants completed the study. Cost of treatment was identified as a main deterrent, while proof of treatment success was identified as a main facilitator for treatment uptake. A majority of participants (88.5%) indicated a preference for face-to-face treatment. In multiple regression analyses, after controlling for relevant demographic variables and pain intensity, PF explained 14% of the variance for pain interference and impact of depressive symptoms and 22% of the variance for depressive symptoms.

Conclusion: A focus on meeting patients' needs at low cost, and providing proof of treatment success may increase psychological treatment uptake.

Increasing PF for pain in people from Singapore may also contribute to better patient functioning.

Keywords: Chronic pain; treatment needs; treatment delivery preferences; psychological flexibility; cross-sectional study; Singapore

Introduction

Chronic pain is a condition that creates many significant problems in the lives of people who suffer with it (Breivik et al., 2006; Turk, 2002). Modest benefits provided by conventional medical treatments alone have led to a shift towards considering the relevance of psychosocial factors in the treatment of chronic pain and related disability. Behavioural and cognitive-behavioural methods that address these factors have had a significant impact on the management of chronic pain, and contributed greatly to our ability to more effectively treat this condition (Ehde et al., 2014; Jensen & Turk, 2014). These methods are not uniformly available all around the world and it can be unclear how to best design and deliver these in distinctive national and cultural contexts where they have not yet been fully developed.

Acceptance and Commitment Therapy and Chronic Pain

Psychological treatment models for chronic pain continue to develop. In recent years this has included contextual cognitive behavioural approaches (Hayes et al., 1999; McCracken, 2005; McCracken & Morley, 2014), such as Acceptance and Commitment Therapy (ACT) and mindfulness-based therapies. At the core of ACT is the concept of psychological flexibility (PF). The PF model combines cognitive and behavioural principles and applies these principles specifically to one's ability to persist or change behaviour in ways that are goal-directed (Hayes et al., 2011). PF is enhanced through a focus on six core processes organized in three clusters and referred to as 'open' (cognitive defusion-acceptance), 'aware' (present moment awareness-self as context) and 'engaged' (values-committed action) (Hayes et al., 2012). Simply defined, cognitive defusion is a process of reducing the impact of thoughts on behaviour by raising awareness of the distinction between thoughts and the people or

objects to which they relate. Acceptance involves the patient's willingness to have pain while still engaging in meaningful activities. Contact with the present moment is the process of flexible present-focused awareness. Self-as-context is a sense of self that is not defined by or entangled in thoughts and feelings, a sense of self that is above or bigger than the content of experience. Values are considered to be guiding principles in one's life or qualities of action one regards as personally important, and committed action includes persistent behaviour patterns that are guided by goals and values (Hayes et al., 2006). The PF model provides a focus on treatment processes that link treatment methods with outcomes (McCracken & Morley, 2014). Through this focus, methods are able to be developed and improved through a process of testing and improving the mediation of treatment effects, a more direct means for understanding and tracking treatment impact than could be done with such process variables.

A recent systematic review on ACT treatment trials for chronic pain suggested that ACT is effective for enhancing general functioning and reducing emotional distress in comparison to inactive comparison conditions (Hann & McCracken, 2014). Five meta-analyses have been conducted on ACT-based intervention studies (Ost, 2008; Powers et al., 2009; Ruiz, 2012; Veehof et al., 2011, 2016) but only two specific to chronic pain (Veehof et al., 2011, 2016). These two meta-analyses conducted by Veehof and colleagues (Veehof et al., 2011, 2016) and including studies of ACT and mindfulness-based treatments for chronic pain, concluded that these treatments may not be more effective than conventional Cognitive Behavioural Therapy (CBT) but could be good alternatives to this approach.

Psychological Treatment for Chronic Pain in Asia

Similar models of healthcare service delivery appear to exist for the treatment of chronic pain in many parts of East and Southeast Asia, and these models do not typically include psychological treatments (Cardosa et al., 2012; Nicholas et al., 2006; Tan et al., 2009). The literature that addresses the efficacy of psychological treatments for chronic pain in these parts of Asia are also limited, mostly preliminary, with only seventeen studies published since 2002, including only four randomised controlled trials (RCTs), and none of the studies addressing ACT (Yang et al., 2016a).

A recent qualitative study of people with chronic pain in Singapore reported that barriers such as cost, time, access to appointments and resources, and a lack of knowledge of the relevance of psychological treatment for chronic pain may impede uptake of psychological treatment (Yang et al., 2015). Verifying the potential role of these factors in a larger sample of people from the same population could be a constructive next step.

Evidence for ACT in Asia

The basic foundations of ACT and related therapies appear consistent with longstanding Asian philosophies and reflect East Asian cultural values and norms (Hall et al., 2011). Even so ACT has been applied and studied mostly in Western settings, and evidence for processes of PF and ACT remains limited in Asia.

Correlation studies assessing the role of processes related to ACT in Asian populations have examined the association of PF with job performance (Kishita & Shimada, 2011), the impact of ACT on drug refractory epilepsy in India (Lundgren et al., 2008), and on the psychological health of Japanese students based outside of Japan (Muto et al., 2011). Each of these studies provides support for the potential benefits of ACT. The first experimental study

of ACT methods for pain in an Asian context was a laboratory based study of pain tolerance with Japanese students studying in America (Takahashi et al., 2002). Results demonstrated that participants in the acceptance intervention condition had greater pain tolerance relative to those in the comparison condition.

There are currently only about three studies of ACT including people with chronic pain from East Asia, and none of these were treatment studies (Cheung et al., 2008; Cho et al., 2012, 2013). Two of the studies focused on validation of translated versions of the Chronic Pain Acceptance Questionnaire (CPAQ) in Chinese (Cantonese) in Hong Kong (Cheung et al., 2008) and in Korean (Cho et al., 2012). Both studies found good test-retest reliability internal consistency, and good construct validity of the CPAQ as a measure of pain acceptance. Additional results supported the applicability and validity of the process of acceptance within these samples. The third study was a diary study conducted in a sample of Korean patients with Complex Regional Pain Syndrome (CRPS-1) (Cho et al., 2013). Results from this study showed that pain acceptance based coping was associated with reduced pain and negative mood, and increased activity. None of these studies were conducted in Southeast Asia.

Study Rationale and Aims

Treatments for chronic pain, particularly those including a psychological component, are not well developed in Southeast Asia, including Singapore. In order to develop and deliver such treatments, both practical methods of delivery and appropriately fitting psychological models must be chosen. Different national, healthcare, and cultural context likely entail different needs and potential barriers for services users. Understanding these is important to be sure that services are appropriate in focus, accessible, and likely to be used.

Likewise, there is an assumption that the PF model may have particular relevance and applicability in the culturally and linguistically diverse cultures of Asia (Hall et al., 2011; Hayes, Muto & Masuda, 2011). However, further studies would need to be done to test this. With English spoken as the first language, an established healthcare system and a mix of four communities, Chinese, Malay, Indian and Eurasians, conducting this study in Singapore appeared appropriate and potentially fruitful.

The specific aims of the present study were two-fold. The first was to examine with quantitative methods, psychological treatment barriers and needs derived from a previous qualitative study (Yang et al., 2015), including treatment delivery preferences in current users and non-users of conventional healthcare treatment for chronic pain in Singapore. It is possible that the psychological treatment needs between these groups of participants may differ. Results will contribute to a broader understanding of psychological treatment needs and better inform treatment design and delivery for people with chronic pain. The second was to examine if “in principle” PF therapy process that appear useful within the functioning of mostly western populations with pain also appear useful within the functioning of people in Singapore with chronic pain. Validated measures of PF in chronic pain studies have predominantly included measures of pain acceptance, general acceptance and committed action. These measures were also selected for this study. Together, these aims are intended to guide the design of methods for delivering psychological treatment and the treatment components included in that delivery. Results can then be applied to guide health care service policy and development. Based on results from previous studies, (Kishita & Shimada, 2011; McCracken, 1998, 2013; McCracken & Zhao-O’Brien, 2010; Viane et al., 2003; Vowles et al., 2014) we

predicted that our results would show that the three facets of PF assessed here would each significantly predict levels of participant functioning, including pain-related interference, depressive symptoms and impact of depressive symptoms, including in analyses where levels of pain severity are statistically controlled.

Methods

Design

This was a cross-sectional questionnaire study including participants with chronic pain recruited from pain services and via an online portal.

Participants

Participants were recruited face-to-face at the Pain Management Clinic (PMC) at Tan Tock Seng Hospital (TTSH), in Singapore, as well as through an online invitation open to the public and posted on the PMC website, with printed copies of the study invitation also made available at the PMC. There are only two tertiary public hospitals in Singapore that offer interdisciplinary pain treatment services for people with chronic pain. Treatment services offered at PMC include pharmacotherapy, minimally invasive treatments, pain nursing education, psychological interventions, physiotherapy and occupational therapy. Such services are delivered via individual face-to-face sessions and via structured group program formats. Psychological intervention is cognitive behavioural therapy-based, with a mix of CBT and ACT interventions used in treatment, matching the individual training of the psychologists.

The clinic website for TTSH was regarded as an appropriate recruitment site as it was designed as a general publically available resource and likely to be widely visited. It includes educational articles, practical tips, and other information about pain management that people with chronic pain are likely to seek and access. Participants were asked to complete a two-part survey related

to treatment for chronic pain as well as a set of measures of pain, daily functioning, and selected processes of PF, including pain acceptance, general acceptance and committed action. All participants were allocated a participant number that allowed data collected to remain anonymous.

Participants were included if they were (a) above the age of 21 years old (b) diagnosed with chronic nonmalignant pain (non-cancer pain) for more than three months (c) citizens or permanent residents in Singapore and (d) able to complete the full set of questionnaires without assistance. On the online survey, this was determined by participants' initial survey responses. The survey was designed such that questions meant to elicit responses relating to the inclusion criteria were arranged on the first page of the survey. Participants who met the inclusion criteria were directed to complete the full survey. Those who did not meet criteria were directed to an information page. Here, participants were informed that further completion of the survey was not required as study criteria were not met.

Participants were excluded from the face-to-face recruitment if they (a) were diagnosed with a significant, relevant, cognitive impairment as documented in neurological or neuropsychological assessment findings, (b) were diagnosed with a current mental illness or health problems expected to significantly interfere with study participation or (c) did not have the capacity to give informed consent. The exclusion criteria were only applied to participants recruited at the PMC. As the online survey was anonymous, and participants' medical records were not available, participation on the online survey was primarily determined by the inclusion criteria.

Study Recruitment

A total of 227 participants were initially recruited for this study. Of the total number of participants recruited, 77 participants were recruited face-to-face and 150 participants began the survey online. The dual method of recruitment served the purpose of sampling a wider group of people with chronic pain in the community. Data on the total number of participants who declined participation via online recruitment are not provided as limited resources prevented tracking of the total number of people that accessed the PMC website. Among the 77 invited face-to-face, 12 declined, four did not meet criteria, and four dropped out, leaving 57 participants who completed the pen and paper version of the survey. Of those who initiated the survey online, five did not meet study criteria and two dropped out, leaving 143 participants who completed the online version. Hence, a total of 200 participants (112 women, 88 men) completed the study.

To assess possible differences in survey opinions between participants currently seeking conventional medical treatment at PMC, those seeking other treatments not within PMC, and those not seeking any form of treatment, the labels 'PMC users', 'non-PMC' and 'non-users' were applied respectively. PMC users were currently undergoing some form of regular conventional healthcare treatment from a professional provider for their pain at PMC. Both single disciplinary treatment services and structured, interdisciplinary pain programs were offered at PMC. Patients who received single disciplinary treatment were seen by one or more of the interdisciplinary team of medical and allied health professionals such as a pain specialist, psychologist, physiotherapist, or occupational therapist. Patients who received treatment within a structured, interdisciplinary program offered at PMC received treatment by a team,

comprising of a pain specialist, pain nurse, psychologist and physiotherapist over 2-weeks or 3-weeks. Patients assessed to have higher pain impact in their lives were usually referred for the 3-weeks program. Non-PMC users reported using similar treatments but only within single disciplinary settings. These included treatment by a General Practitioner (GP), private specialist treatment, or treatment by a private allied health professional such as a psychologist, physiotherapist, or occupational therapist. Non-users included individuals who self-medicated, sought treatment from a traditional Chinese medicine practitioner or alternative treatment providers (i.e. chiropractors and osteopaths). These participants may have previously sought some form of conventional treatment but are not currently seeking such treatment. Our final sample included a total of 69 PMC users, 68 Non-PMC users and 63 non-users.

Ethics

Ethical approval for the study was received from the relevant institutional ethics committee, Domain Specific Review Board (DSRB; 2012/00717). Informed consent was obtained from all individual participants included in the study.

Measures

Participants completed a series of assessment instruments at only one time point. Background characteristics were assessed, including pain duration, location, days of medical leave, and healthcare usage, including pain-related doctor and emergency care visits over the past three months.

Survey on Treatment Barriers and Treatment Needs

A survey including a list of independent items assessing potential barriers and needs for psychological treatment related to chronic pain was developed for the purpose of this study. This was not meant as a psychometric

measure that yields a summary scale score. The first eight items assessed factors that might discourage uptake of psychological treatment and the other eight items assessed factors that might encourage uptake of psychological treatment. These items were derived from a previous qualitative study (Yang et al., 2015). Participants rated these items on a scale of 0 (not important at all) to 10 (very important). The two sets contained precisely parallel content, with the difference being that they were examined as either barriers or facilitators. Additional survey questions on participants' preferences in the delivery formats of psychological treatment followed those used in a previous mixed methods study (McCracken, Sato, Wainwright et al., 2014) (see Appendix E for details of the survey).

Pain Intensity

Present and average pain intensity over the past week was assessed using a 0 (no pain) to 10 (worst possible pain) numerical rating scale. To obtain an overall pain intensity score, pain intensity was calculated by averaging the two ratings into one pain intensity component (Dworkin et al., 1990; Von Korff et al., 1992).

Measures of Functioning

Brief Pain Inventory (BPI) – interference scale.

The BPI (Cleeland & Ryan, 1994) interference scale measures the level of pain interference in daily activities with participants rating each item on a scale from 0 (never interferes) to 10 (completely interferes). The BPI interference scale has demonstrated adequate internal consistency ($\alpha > 0.70$) and reliability with Cronbach's alpha ranging between 0.93-0.95 (Keller et al., 2004). The IMMPACT panel on assessment methods for clinical trials has also specifically identified the interference items of the BPI as one of their

recommended measures of assessment of pain-related functional impairment in clinical trials (Dworkin et al., 2005).

Patient Health Questionnaire-9 (PHQ-9)

The PHQ-9 is a 10-item measure of depression (Kroenke et al., 2001). The sum of the first nine items scored from 0 (not at all) to 3 (nearly every day) is used as an index of the severity of depression. The tenth item is a single item used here as a measure of the interference of depressive symptoms in one's life. It is intended and used as a separate index of the impact of depressive symptoms, particularly for use in screening for depressive symptoms that meet the diagnostic criteria as a disorder. The internal reliability of the PHQ-9 has a Cronbach's alpha of 0.89 with good test-retest reliability (Kroenke et al., 2001).

Process Measures of PF

Chronic Pain Acceptance Questionnaire-8 (CPAQ-8)

The CPAQ-8 (Fish et al., 2010) is a short version of the original 20-item inventory (CPAQ) measuring acceptance of pain (McCracken et al., 2004). Participants rate the eight items on a scale from 0 (never true) to 6 (always true). Good internal consistency reliability ($\alpha = 0.77$ to 0.89) and validity has been demonstrated for this scale (Fish et al., 2010).

Acceptance and Action Questionnaire-II (AAQ-II)

The AAQ-II (Bond et al., 2011) is a seven-item scale developed to assess general/ psychological acceptance. The AAQ-II appears to measure the same concept as the AAQ (Hayes et al., 2004) but with better psychometric properties. Participants are asked to rate each statement on a scale from 1 (never true) to 7 (always true). The AAQ-II has adequate psychometric characteristics, including internal consistency ($\alpha = 0.78$ to 0.88) and good test-retest reliability ($r = 0.79$ to 0.81).

Committed Action Questionnaire (CAQ)

The CAQ is an 18-item measure of committed action as defined within the PF model (McCracken, 2013). Committed action includes flexible and persistent goals-based action. Participants are asked to rate how well each statement applies to them. Each of the items is rated on a scale from 0 (never true) to 6 (always true). The psychometric characteristics of the CAQ have been adequately demonstrated, including internal consistency ($\alpha = 0.87$).

Statistical Methods

To account for the highly skewed data obtained for duration of pain, these data were transformed with a log transformation. These transformed data were used in subsequent analyses.

For the barriers and needs survey, the primary questions concerned the rated importance of barriers and facilitators overall. However, comparisons were also made between PMC users, non-PMC users and non-users with regard to their reported treatment opinions and preferences. Descriptive statistics, chi-square, one way ANOVAs and post-hoc Tukey's HSD test were conducted. One way ANOVAs were also used initially to test potential differences among PMC users, non-PMC users and non-users on pain intensity, dependent variables (DVs) of pain interference and emotional functioning and PF. As the focus of the study was to test the general utility of PF in our target sample, and not potential differences of PF between PMC users, non-PMC users and non-users, subsequent analyses included analysing data as a whole. Correlation analyses assessing the relationship between demographic variables, pain intensity, DVs, and the three measures of PF were then conducted. Next, hierarchical multiple regression was used to assess the role of PF in accounting for the variance in pain intensity and the DVs. These analyses were also

designed to statistically control the role of relevant participant demographic variables as well as pain intensity. Demographic variables including age, gender, education, and pain duration were tested as possible correlates with the DVs and entered together in step one where significant. Pain intensity was entered on the next step and the three PF variables on the final step. To test whether the order in which variables were entered made a difference to the predictor value of pain intensity, in the final set of analyses, pain intensity was entered in as a predictor after the PF variables.

Results

Participants had a mean age of 45.27 years (SD = 12.88), mean pain duration of 43.61 months (SD = 65.31), and a mean of 13.27 (SD = 3.11) years of education. A majority of participants were Chinese (83%), married (64%) and in full-time employ (68.5%). Table 1 provides a summary of participants' demographics.

Table 1: Summary of demographics of PMC users, non-PMC users and non-treatment users

		PMC Users	Non-PMC	Non-Users
		Mean (SD)	Mean (SD)	Mean (SD)
Age		45.75 (13.39)	45.90 (12.42)	44.05 (12.93)
Pain duration***		61.41 (70.43)	39.92 (67.35)	28.11 (52.30)
Average years of education		12.64 (3.30)	13.62 (2.87)	13.57 (3.09)
		PMC Users	Non-PMC	Non-Users
		No. (%)	No. (%)	No. (%)
Sex*	Male	21 (30.4)	32 (47.1)	35 (55.6)
	Female	48 (69.6)	36 (52.9)	35 (55.6)
Race	Chinese	50 (72.5)	61 (89.7)	55 (87.3)
	Malay	8 (11.6)	3 (4.4)	4 (6.3)
	Indian	9 (13.0)	2 (2.9)	2 (3.2)
	Eurasian	1 (1.4)	1 (1.5)	2 (3.2)
Pain Site**	Low back	36 (52.2)	25 (36.8)	19 (30.2)
	Upper extremities	10 (14.5)	6 (8.8)	13 (20.6)
	Legs/feet	3 (4.3)	16 (23.5)	23 (36.5)
	Others	10 (14.5)	14 (20.6)	5 (7.9)

PMC: Those utilising PMC services, Non-PMC: Utilising pain services elsewhere, Non-User: Not utilising services at PMC or any pain service elsewhere.

Note: *p < .05, **p < .01, ***p < .001

Preliminary Analyses

There was a significant difference in duration of pain between the participant groups, $F(2, 199) = 15.74, p = .000$. Post-hoc comparisons indicated that the mean pain duration for PMC users significantly differed from non-PMC users and non-users, with PMC users suffering a longer duration of pain. There were also differences in gender [$\chi^2(2, N = 200) = 8.83, p = 0.01$], and pain site [$\chi^2(18, N = 200) = 40.90, p = 0.002$] between participants. PMC users were more likely than non-users to be women 69.6% vs 44.4%, and more likely to have low back pain, 52.2% vs 30.2%. Non-users were more likely to have leg or foot pain 36.5% vs 4.3%.

Further group differences emerged with regard to pain intensity, pain interference, impact of depressive symptoms, and pain acceptance. Post-hoc comparisons indicated significant mean differences in level of pain intensity between PMC users and both non-PMC users and non-users. The mean levels of pain interference, impact of depressive symptoms and pain acceptance significantly differed between PMC users and non-users but not with non-PMC users (see Table 2).

Table 2: Summary of means, standard deviations (SD) and mean differences on measures of functioning and psychological flexibility

	PMC	Non-PMC	Non-user	
	Mean(SD)	Mean (SD)	Mean(SD)	F (2, 199)
<i>Dependent Variables</i>				
Pain intensity**	4.69 (2.21)	3.74 (2.37)	3.29 (2.14)	7.38, p =0.001
Pain interference*	3.60 (2.64)	2.91 (2.55)	2.32 (2.14)	4.47, p = 0.01
Depressive Symptoms	6.38 (6.66)	4.81 (6.27)	4.06 (4.87)	2.57, p = 0.08
Impact of Depressive Symptoms***	0.58 (0.50)	0.34 (0.48)	0.27 (0.45)	8.64, p = 0.00
<i>Process Measures</i>				
Chronic Pain Acceptance Questionnaire-8*	26.41 (6.80)	28.10 (6.36)	29.60 (6.14)	4.06, p = 0.02
Acceptance Action Questionnaire-II	22.78 (12.44)	19.24 (9.61)	19.40 (9.84)	2.36, p = 0.10
Committed Action Questionnaire	66.70 (13.53)	67.51 (12.91)	66.97 (13.63)	0.07, p = 0.94

PMC: Those utilising PMC services, Non-PMC: Utilising pain services elsewhere, Non-User: Not utilising services at PMC or any pain service elsewhere.

Note: *p < .05, **p < .01, ***p < .001

Work Absence and Healthcare Usage

Overall, participants reported a low rate of medical leave. Almost half of PMC users (47.8%) and non-PMC users (45.6%), and more than half of non-users (74.6%) reported zero medical leave days. Reports of medical visits in the past three months such as doctor visits, Accident and Emergency (A and E) visits and hospitalisation days were also low. Due to low usage of such

healthcare services for all participant groups, and low overall variability, data regarding healthcare usage were not further analysed. Table 3 shows the percentage use of health related visits.

Table 3: Summary of healthcare visits for PMC user, Non-PMC users and non-users

	PMC Users	Non-PMC Users	Non-Users
	Median (Range)	Median (Range)	Median (Range)
MC Days	1.5 (0-365)	1 (0-90)	0 (0-30)

	PMC Users	Non-PMC Users	Non-Users
	No. (%)	No. (%)	No. (%)
Two or less doctor visits in the past 3-months	57 (82.6)	55 (80.9)	60 (95.2)
Zero use of A & E visits in the past 3-months	66 (95.7)	64 (94.1)	61 (97.1)
Two or less hospitalisations in the past 3-months	67 (97.1)	64 (94.1)	62 (98.4)

Barriers and Needs Survey

Results from the barriers and needs survey demonstrated that ratings of barriers and facilitators to psychological treatment were similar across all three participant groups. In particular, participants rated cost of treatment (Mean = 7.65, SD = 2.65) as the main barrier to psychological treatment uptake, and rated proof of treatment success (Mean = 8.86, SD = 1.61) as the main facilitator to treatment uptake.

PMC users, non-PMC users and non-users did not differ significantly in their opinions on many of the “barriers and needs” survey items that were assessed. Results showed that the opinions of PMC users, non-PMC users and non-users differed on proof of treatment success $F(2, 199) = 4.97, p = 0.008$, and access to treatment, $F(2, 199) = 11.77, p = 0.00$. Post-hoc comparisons indicated that compared to PMC users, only non-users felt a stronger need for proof of treatment success to take up treatment. Compared to PMC users, both non-PMC users and non-users supported improved treatment access to facilitate treatment uptake. There were no significant differences in opinions between non-PMC users and non-users.

Participants differed in their opinion on the lack of information about psychological treatment as a barrier to psychological treatment uptake (see Table 4). Post-hoc comparisons indicated that compared to PMC users both non-PMC users and non-users more strongly endorsed a lack of information about psychological treatment as a main treatment barrier. There were no significant differences in opinions between non-PMC users and non-users.

As the item sets related to the barriers and needs survey were designed in parallel, and few differences emerged between the two sets, only a single summary set of the mean ratings, those for potential treatment barriers, are presented in Table 4 (complete data for both sets of items are available from the first author).

Table 4: Summary of means, standard deviation (SD) and mean differences between PMC users, Non-PMC users and non- treatment users on barriers to psychological treatment

Barriers	PMC	Non-PMC	Non-user	<i>F</i> (2, 199)
	Mean (SD)	Mean(SD)	Mean(SD)	
High cost of treatment	7.10 (2.84)	8.09 (2.42)	7.78 (2.60)	2.52, <i>p</i> = 0.08
Lack of information about CBT**	6.36 (2.72)	7.47 (2.65)	7.73 (2.51)	5.12, <i>p</i> = 0.007
Calling the treatment psychological	4.91 (3.13)	5.62 (3.02)	5.33 (2.99)	0.93, <i>p</i> = 0.40
Stigma	3.51 (3.51)	2.85 (3.00)	3.41 (3.21)	0.80, <i>p</i> = 0.45
Poor social support	4.64 (3.59)	4.21 (3.25)	4.00 (3.65)	0.58, <i>p</i> = 0.56
Hospital-based treatment	4.48 (3.42)	4.63 (3.19)	5.40 (3.12)	1.49, <i>p</i> = 0.23
Lack of explanation by referring health professional	6.42 (2.95)	7.21 (2.82)	7.44 (2.64)	2.44, <i>p</i> = 0.09
Poor relationship with health professionals	6.12 (3.13)	6.46 (3.22)	7.14 (2.96)	1.85, <i>p</i> = 0.16

PMC: Those utilising PMC services, Non-PMC: Utilising pain services elsewhere, Non-User: Not utilising services at PMC or any pain service elsewhere.

Note: ***p* < .01

Preliminary analyses indicated that there were no significant difference in type of treatment delivery preferences between PMC users, non-PMC users and non-users. As a whole, participants preferred face- to-face treatment (88.5%) followed by online treatment delivery (28%) and a combination of treatment methods (26.5%). The largest group of participants, who preferred a combination of treatment methods, expressed a preference for face-to-face treatment in combination with online treatment (43.4%). Participants (74%) also

felt that a distribution of leaflets and brochures on psychological treatment for chronic pain could best promote treatment uptake.

Overall, participants preferred a schedule of once per week treatment sessions lasting an average of 45 minutes for a median of four to five sessions. Participants were willing to pay an average of S\$37.46 (SD = 19.45) per treatment session.

Descriptive Statistics

The means and standard deviations from the measures of pain intensity, participant functioning, and PF are summarized in Table 2. As for impact of depressive symptoms, 40% of all participants indicated some degree of impact of depressive symptoms while 60% indicated no impact of depressive symptoms on their daily functioning. A comparison between participant groups showed that 58% of PMC users, 33.8% of non-PMC users and 27% of non-users indicated that depressive symptoms created an impact on their lives.

Correlation Analyses

Correlation analyses were conducted to examine the relationships between participant demographic variables, pain intensity, pain interference, depressive symptoms, impact of depressive symptoms and the total scores on the CPAQ-8, AAQ-II and CAQ.

Among the demographic variables, years of education showed small relationships ($r = -0.20$ to $r = 0.30$) with age, pain intensity pain interference, depressive symptoms and pain acceptance. Pain duration showed small relationships ($r = 0.15$ to 0.26) with pain intensity, pain interference and impact of depressive symptoms, and age also had a small relationship with impact of depressive symptoms ($r = -0.15$). All other relationships between demographic

variables, pain intensity, measures of participant daily functioning, and measures of PF were not significant.

Small to moderate correlations were found between pain acceptance, general acceptance, committed action and measures of pain intensity, pain interference, depressive symptoms and impact of depressive symptoms. Mainly moderate inter-correlations were found between primary variables of interest. Table 5 provides the correlation matrix of these primary variables of interest.

Table 5: Correlation matrix of measures of pain intensity, functioning and process variables

	Pain Intensity	Pain Int.	DS	IDS	CPAQ-8	AAQ-II	CAQ
Pain Intensity	1	0.67**	0.44**	-0.25**	-0.15*	-0.18*	-0.13
Pain Int.	0.64**	1	0.67**	-0.20**	-0.69**	-0.38**	-0.26**
DS	0.44**	0.67**	1	-0.20**	-0.41**	-0.52**	-0.36**
IDS	0.43**	0.65**	0.63**	1	-0.38**	-0.37**	-0.25**
CPAQ-8	-0.15*	-0.69**	-0.41**	-0.38**	1	0.48**	0.50**
AAQ-II	-0.18*	-0.38**	-0.52**	-0.37**	0.48**	1	0.45**
CAQ	-0.13	-0.26**	-0.36**	-0.25**	0.50**	0.45**	1

Pain Int.: Pain Interference; DS: Depressive Symptoms; IDS: Impact of Depressive Symptoms; CPAQ-8: Chronic Pain Acceptance Questionnaire-8; AAQ-II: Acceptance and Action Questionnaire-II; CAQ: Committed Action Questionnaire.

Note: *p < .05, **p < .01

Regression Analyses

Hierarchical multiple regression analyses were carried out to investigate the combined contribution of the three measures of PF in accounting for

variance in the DVs. Variance estimates (ΔR^2) and standardised regression coefficients (β) for these analyses are displayed in Table 6.

Table 6: Results of hierarchical regression analyses examining psychological flexibility in relation to measures of functioning

Block	Predictor	β	ΔR^2	Total R^2
<i>Pain Interference</i>				
1.	Sex	-0.04	0.08**	0.57***
	Age	-0.09		
	Education	-0.01		
	Pain Duration	-0.02		
2.	Pain Intensity	0.60***	0.35***	
3.	CAQ	0.08	0.14***	
	AAQ	-0.20**		
	CPAQ	-0.29***		
<i>Depressive Symptoms</i>				
1.	Sex	-0.03	0.09**	0.44***
	Age	-0.02		
	Education	-0.07		
	Pain Duration	0.06		
2.	Pain intensity	0.34***	0.14***	
3.	CAQ	-0.06	0.22***	
	AAQ	-0.38***		
	CPAQ	-0.13		
<i>Impact of Depressive Symptoms</i>				
1.	Sex	0.05	0.08**	0.34***
	Age	-0.21		
	Education	0.09		
	Pain Duration	0.04		
2.	Pain intensity	0.34***	0.12***	
3.	CAQ	0.04	0.14***	
	AAQ	-0.17*		
	CPAQ	-0.31***		

CAQ: Committed Action Questionnaire; AAQ: Acceptance and Action Questionnaire II; CPAQ: Chronic Pain Acceptance Questionnaire-8

Note: * $p < .05$, ** $p < .01$, *** $p < .001$

As shown in Table 6, the background variables did not account for a significant amount of variance in the DVs. Pain intensity accounted for 35% of the variance in pain interference, 14% for depressive symptoms and 12% for impact of depressive symptoms. After controlling for pain intensity, the addition of the three primary process variables resulted in an increment of 14% of variance for pain interference, 22% for depressive symptoms, and 14% for the impact of depressive symptoms. Pain intensity made the strongest contribution to pain interference while PF made the strongest contribution to depressive symptoms.

Among the three process variables of PF, pain acceptance contributed the most variance to impact of depressive symptoms while general acceptance made the strongest contribution to depressive symptoms. Committed action did not significantly contribute to variance for any of the outcomes in these multivariate analyses.

We also tested the effect of varied approaches to the regression analyses. Examination of the data using the stepwise rather than standard entry regression method did not show a significant change in the results, hence we report only one set of regression analyses here. In a final set of analyses, we tested whether a change in entry order of pain intensity and the PF variables in the multiple regression equation would make a significant change in their contributed variance to the DVs. In these analyses pain intensity was entered after the PF variables in the stepwise regression equation. There were no significant changes in variance accounted for from pain versus PF from doing this.

Discussion

This study focused on two aims. The first was to examine with quantitative methods, psychological treatment barriers and needs derived from a previous qualitative study (Yang et al., 2015) and treatment delivery preferences in PMC users, non-PMC users, and non-users of conventional healthcare treatment with chronic pain in Singapore. The second was to examine the relevance of the PF model to daily functioning for this group by investigating associations between PF and pain-related outcomes. Preliminary results indicate that users of conventional healthcare treatment, especially those utilising services at PMC had a different profile from non-users of conventional medical treatment. PMC users were more likely to be women, suffering longer pain duration, with higher pain intensity, pain interference and impact of depressive symptoms, and lower pain acceptance. This result is not surprising as PMC is one of only two specialised pain services within re-structured (partially government funded) hospitals in Singapore with the capacity to provide interdisciplinary care. It is only natural that patients with a higher negative impact of pain in their lives and continue to struggle with managing pain would seek specialty healthcare services. Interestingly, pain duration was the only differentiating factor between those that sought PMC services and those that sought conventional medical treatment elsewhere. It would appear that patients' decision to seek more specialised care was primarily based on the duration of pain suffering itself rather than on factors associated with the wider impact of pain on daily functioning. The design of healthcare systems and referral processes for specialist care in the public hospitals in Singapore may contribute to this.

In general, PMC users, non-PMC users and non-users shared mostly similar opinions on many factors that may discourage and encourage psychological treatment uptake. In particular, cost of treatment was identified as a main barrier, while proof of treatment success was identified as a main facilitator to treatment uptake. Patients seeking pain services view the costs of treatment in Singapore as high and expressed a lower willingness to pay for other forms of treatments other than medications and doctor visits (Yang et al., 2015). In this current study, participants expressed a willingness to pay an average of S\$37.46 per psychology session. Psychology sessions are currently charged at approximately S\$90.00 per session at PMC (Tan Tock Seng Hospital, PMC internal statistics), an amount much higher than the amount that participants are willing to pay. Addressing this practical barrier of treatment costs in relation to patients' needs in Singapore, as well as providing evidence for psychological treatment in the treatment of chronic pain, may increase treatment uptake.

Based on participants' preferences, designing psychological treatment formats that include face-to-face treatment perhaps combined with online treatment may increase treatment uptake. Preliminary findings from a recent feasibility trial combining face-to-face and internet-based treatment for chronic pain, conducted in Singapore, appear to support such a treatment delivery format (Yang et al., unpublished). High treatment satisfaction (81.8%) was reported in this study. As suggested, distribution of leaflets and brochures providing information about treatment may further promote psychological treatment uptake. Of course such materials must be carefully designed and used in conjunction with other methods (National Institute of Health and Clinical Excellence, 2007). Distributing educational materials during the face- to-face

consultation with health professionals knowledgeable of psychological treatments and with whom patients share a therapeutic relationship may help (Yang et al., 2015). Data on psychological treatment preferences here were collected from a relatively small sample of chronic pain patients from one pain clinic and from the community. As such, these results are tentative and need to be further verified.

As for the second aim of this study, in general, results from this cross-sectional study showed associations between our selected measures of daily functioning and the measures of PF, and at least partially supported our predictions. From these we cannot confirm a causal role; however, we can claim that the PF processes are plausible contributors to patient functioning in this population. Processes of PF may also play a role in patients' treatment choices and preferred treatment delivery format for psychological treatment identified here.

Preliminary correlation analyses between PF and participant demographics resulted in only a small relationship shown for years of education with acceptance of pain. The pattern of results obtained, suggest that processes of PF here do not distinguish people based on these types of background characteristics.

Our wider analyses of the relationship between PF with pain interference, depressive symptoms and impact of depressive symptoms yielded mostly small to moderate correlations ($r = -0.25$ to -0.69). A minimal negative relationship exists between PF and pain intensity. This result is not surprising as the relationship between the processes of PF and pain is expected to be indirect at best (Hayes et al., 2011; McCracken & Morley, 2014). These results point to the utility in incorporating elements of PF in the design and content of psychological

treatments for chronic pain in Singapore. In particular, designing treatments focused on increasing pain acceptance and general acceptance, reinforcing an outcome based on engaging in meaningful activities rather than one aimed to reduce pain itself may be more effective. Providing such treatments to PMC users, for whom the impact of pain is highest, may also be the best platform for treatment delivery.

The present correlation results are also similar to previous correlation studies, suggesting a significant role of processes of general acceptance (McCracken & Velleman, 2010; McCracken & Zhao O'Brien, 2010) and pain acceptance (Mason et al., 2008; McCracken et al., 2004) in the well-being and daily functioning of people with chronic pain. Treatment outcome studies have also shown a moderate negative relationship between PF and pain interference (Wicksell et al., 2008) and psychological flexibility and depression (McCracken & Gutierrez-Martinez, 2011; McCracken & Jones, 2012; Vowles et al., 2011). Results imply that increasing PF may lead to lower interference in daily life due to pain and improve emotional functioning.

Regression analyses suggest that PF may have a unique role to play in pain interference, depressive symptoms and impact of depressive symptoms. PF continued to make a unique contribution to these DVs after controlling for background variables of age, gender, education, pain duration and pain intensity. In particular, acceptance of pain contributed the strongest increment of variance among the PF processes to impact of depressive symptoms, and general acceptance made the strongest contribution to depressive symptoms. Committed action did not make a significant unique contribution to any of the DVs.

Committed action did not perform as well as acceptance of pain and general acceptance in explaining variance in pain interference and depressive symptoms in our study. This result is inconsistent with the findings from a validation study of the 18-item Committed Action Questionnaire (CAQ) (McCracken, 2013). In that study, committed action was significantly related to better quality of life, lower levels of depression and better social functioning beyond the contributions of pain intensity and acceptance of pain. Compared to this previous study, our current sample was less disabled by pain, had experienced a significantly shorter pain duration, mild to moderate pain intensity and relatively mild depressive symptoms, with many participants still working in either full-time or part-time work. It is possible that the lower levels of disability in our sample contributed to the poor performance of the CAQ here, or perhaps there are other population, healthcare system, or cultural differences that obscure the types of behaviour patterns observed previously. Another possibility could be the way that our sample understood and responded to items on the CAQ, based on potential cultural or language differences, but this too would need to be further investigated. We note another unexpected result in the current data, in that there was only a small correlation between the two subscales that formed the CAQ, unlike results found in the validation study (McCracken, 2013). An examination of the psychometric properties of the CAQ as it applies to populations in Southeast Asia, including Singapore might be a worthwhile next step. Results from such studies will add to the body of evidence surrounding the validity, applicability and cultural sensitivity of adapted ACT-based measures across diverse populations.

Study Limitations

This study has its limitations. First, this was a cross-sectional, one-time, self-report, questionnaire study. The study design did not allow for comparison of data over time and did not include an experimental manipulation so we cannot draw definite conclusions about causal relations between PF and functioning. Treatment intervention studies including mediation analyses could be one way to further examine the unique contribution of PF to functioning.

Secondly, this study relied on self-reports, including self-reports from anonymous sources who accessed the online version of the questionnaire. Although unlikely, it is possible that participants could have accessed the questionnaire more than once. The online questionnaire was designed to discourage participants from completing it more than once. Unless there were participants who had time to access the survey from more than one device, duplicate data collection is unlikely. The drawback of self-reports is that sometimes patient reports may not precisely reflect actual behaviour, which may compromise the validity and accuracy of our results.

The sample studied is selective in that it only included participants who accessed the healthcare services at the PMC, or a public website affiliated with one hospital in Singapore. We are also unable to fully account for the relatively low usage of healthcare services found in our sample. We might have found different results from a different sample recruited through different recruitment methods. This possibility can be tested in future studies.

This is only one study conducted on the questions addressed, and in one sample population, in one country in Southeast Asia. This is not a definitive study by any means. At the same time it is a first step and further steps ought

to be made to further develop and then implement treatment for chronic pain in Singapore, perhaps including treatments based on PF.

Conclusion

Despite the study limitations, the current study reveals potentially important practical information for future psychological treatment development for chronic pain in Singapore. Results from our study also preliminarily support the utility of the PF model as relevant within a Southeast Asian chronic pain population. Designs of psychological treatment incorporating elements of PF, focused on engaging patients in meaningful activities rather than focused on getting rid of pain itself may prove more effective. Other facets of PF, such as those focused on cognitive and self-related influences (McCracken & Vowles, 2014) also merit further study in settings and contexts not only in Singapore but also in other countries in Southeast Asia.

Acknowledgements

The authors wish to thank Dr Vincent Yeo (Director of the Pain Management Clinic at Tan Tock Seng Hospital) and Sister Tina Png (Clinic Manager) for their approval and support to conduct this study at the Pain Clinic.

Chapter 10: Development of the iACT-CEL intervention program for chronic pain: Rationale, Design, Content and Program Features

10.1 Chapter Overview

The philosophical, theoretical underpinnings and empirical data in support of ACT have been described in Chapter 4. This chapter focuses on providing a rationale for the development of the Internet-delivered ACT-Connect Engage Live (iACT-CEL) program and its design and content, including the technology used in its development. The program layout and core treatment materials used on the program, including selected metaphors and experiential exercises that form the main method of treatment delivery are described.

Singapore is recognised worldwide as a technologically advanced country with technologically savvy citizens. The Global Information Technology Report 2014 (www.weforum.org/gitr), ranked Singapore as 2nd in the world behind Sweden on global networked readiness and information and technologies impacts especially in the social domain. Local statistics in Singapore (www.ida.gov.sg) point to a high usage of the internet countrywide, with 88% of households having access to the internet and 81% of residents aged 7 years above internet users. A recent worldwide study conducted by Google in 2014 (www.consumerbarometer.com) ranked Singapore as having the highest smartphone penetration in the world with an estimated 84% of the population accessing the internet daily via these devices. With such high internet usage recorded in Singapore, applying the internet to healthcare seems a natural opportunity.

10.2 Application of Technology for Psychological Treatment

“Infocomm technology,” a term for the broad spectrum of electronic-communication based technologies, including telecommunication systems, data access, storage, and robotics, is increasingly adopted in healthcare to support and improve the delivery of healthcare services. The use of such technology, in particular internet-based platforms and resources have also been adopted in the delivery of psychological treatment for a broad range of physical and mental health conditions (Cuijpers et al., 2008; Spek et al., 2007; Swartz et al., 2006). Here, CBT-based treatments represent the predominant form of psychological treatment delivered over the internet. As already discussed in Chapter 3, while reviews on internet-based CBT interventions for health conditions have highlighted many limitations in studies of these treatments, including small sample sizes, lack of active control comparisons, heterogeneity of treatment

formats and high dropout rates, general conclusions support the use of the internet as a promising addition comparable to current face-to-face treatments (Bender et al., 2011; Cuijpers et al., 2008; Eccleston et al., 2014; Macea et al., 2010).

10.3 Treatment Rationale: Why ACT?

As already mentioned in Chapter 5, guidelines issued by the APA encourage practitioners to include a culture-centered focus in their practice (APA, 2003). Cultural norms and practices are important contextual factors that can influence an individual's behaviour (Hays, 2009). Tailoring treatments to suit cultural groups, incorporating content, format and treatment delivery styles that are culturally sensitive is more likely to enhance treatment effectiveness than those without such adaptations (Benish et al., 2011; Griner & Smith, 2006; Smith et al., 2011).

Unlike some current psychotherapeutic approaches that can emphasise the following of a specified protocol or treatment manual, the theory and philosophy behind ACT allow for flexibility and are open to creativity, individual style, and situational sensitivity of the therapist, thus, perhaps, allowing and even promoting in the patient a similar sensitivity to changing environmental contingencies (Gaudiano, 2011). As a matter of its philosophical and basic principles, ACT is a highly individualised approach to behaviour change, including individual assessment, tailoring of treatment methods to the person's circumstances, and testing of these for their practical results with these same circumstances (also called "workability").

A recent review on ACT for diverse populations suggested that "the ACT model may be amenable to adaptation and delivery in a variety of contexts and formats and in the treatment of various groups" (Woidneck et al., 2012, p. 231).

In another review, Hayes and colleagues (Hayes, Muto & Masuda, 2011) proposed that as applied to an Asian population, it appears that some particular cultural modification to ACT methods can help contribute to the effectiveness of the ACT treatment model, however the authors did not suggest specific modifications to be made. They argued that adaptations based simply on cultural knowledge would require too many unnecessary variations inherent in existing cultural relationships to be tested (Hayes, Muto & Masuda., 2011). Instead, they suggested that the ability to link cultural knowledge to processes and principles of behaviour change instead of focusing on topography may be more effective (Hayes, Muto & Masuda 2011).

From a broader perspective, Woidneck and colleagues (2012) suggested that the design of any culturally adapted ACT treatment should consider (a) patients' preferred language (b) patient-therapist match on selected demographic variables and (c) include use of adapted metaphors and experiential exercises specific to the treatment population. They further suggested that for such adapted treatments to be effective, therapists delivering treatment will need to acknowledge the influence of cultural factors in treatment, maintain a cultural perspective when conceptualising patients' presenting concerns, and be sensitive to the role and influence of the context of culture in treatment delivery (Woidneck et al., 2012). These suggested adaptations however, have not been widely tested in diverse population groups. An empirical test of these is needed to determine feasibility, acceptability, adaptability and effectiveness of ACT in these settings. A test of treatment delivery via a variety of delivery formats such as the use of technology in the delivery of treatment is also needed (Woidneck et al., 2012).

Considering that the healthcare setting and cultural context in Singapore is unique in many ways to Singapore (as described in Chapter 5), the fluidity of ACT treatments allows the capability to customise some of the content to a Singaporean context. Thus, with its increasing development as an evidence based treatment model for chronic pain, its status as a new development within CBT-based treatments, and its flexibility and sensitivity in design, it is natural to develop an ACT approach for chronic pain treatment in Singapore.

10.4 Delivery Format

In the survey study conducted and presented in Chapter 9, the pool of potential treatment participants ranked face-to-face treatment as their preference with online delivery as their second. While this is important to understand, it is not necessarily possible to accommodate fully this single most preferred option. Here the chosen delivery design was to blend the two top preferences. An online treatment delivery system with minimal therapist support was deemed the best package. This was to reduce costs and increase access (Cuijpers et al., 2008), thus accommodating identified potential barriers identified in this earlier study. It was also to accommodate the limited number of psychologists specialising in chronic pain treatment in Singapore, so that they might effectively treat a larger number of patients during the allocated clinic schedule. Online treatment delivery may also address potential barriers around time commitment and transportation (Keogh et al., 2010; Williams, 2011). The wider use of technology including the internet, webinar and smart phone devices as part of treatment delivery is suggested as a way to increase uptake of psychological treatment for people with chronic pain in Singapore (Yang et al., 2015, 2016b).

To my knowledge, this treatment protocol and delivery platform would be the first of its kind in Singapore and Southeast Asia for chronic pain. There is therefore much untapped potential that can be developed in this area.

10.5 Behaviour Change Principles

As outlined in previous chapters, ACT is a principle and process focused treatment. For example, when people with health problems get caught up with a problem whether it is pain, distress, discomfort, or another experience they do not want, a natural response is to try and fix it or get rid of it so that they can move on in life. They may put life on hold, blaming these problems for hindering their progress, believing that pain needs to be reduced before they can start living life again. Maybe being able to live life is not about getting rid of these problems but instead to deal with them from a different perspective. ACT is simply just that, a way to put aside conventional forms of thinking allowing for a fundamental change in the way one deals with personal experience (Hayes, 2005) (details already discussed in Chapter 4).

ACT methods provide new ways to approach difficult psychological issues including managing chronic pain. The main aim of ACT is to create full and meaningful participation in life, while accepting the pain that life inevitably brings. As an aside, this acceptance is meant to be in the present moment only, not extended into the future, not forever all at once. ACT helps the individual connect with what truly matters, core values that are important, and then using these core values to guide, motivate and inspire behaviour change. ACT also encourages mindful action: action taken with full awareness and engagement (Harris, 2009). Through building on psychological skills that help to lessen the impact and influence of difficult thoughts and feelings, individuals are able to clarify their values (what is meaningful to them) while setting goals and taking

committed action to fulfil these goals (Harris, 2009). Hence, behaviour change in ACT is broadly achieved through mindful-action, acceptance and values-based action (Hayes, 2005). All three of these components incorporated into the iACT-CEL program.

10.6 Designing an Internet-based ACT Intervention

Content Structure of Current Interventions

There are at present only two published ACT-based internet delivered interventions for chronic pain (Buhrman et al., 2013, Trompetter et al., 2015a). These interventions were designed and delivered to Swedish and Dutch populations respectively. These studies were delivered in the language of the targeted populations and have not been translated or replicated in English. These two studies were similar in that the six core ACT processes were presented through individually tailored sessions solely delivered online. A mix of audio files and text were used in the delivery of these sessions, with supplementary reading material related to experiences of other people with chronic pain also provided. Interactive exercises via the web-portal were also included as part of treatment. Sessions were delivered once a week and therapist support was provided via structured e-mails.

The interventions in these two studies differed mainly on the total number of sessions included, and selection of type and number of experiential exercises, metaphors and mindfulness exercises that were included on the programs. Trompetter and colleagues' (2015a) study had an added minimum time expectation for participants to work through each session and also included a small number of therapist presented videos on their program. Buhrman and colleagues' (2013) study included short structured phone calls at specific points in their intervention as a form of added support.

Content Structure of iACT-CEL

In many aspects, the basic framework of the iACT-CEL intervention was similar to that of the Swedish and Dutch interventions, included recommendations from a recent Cochrane review on internet-based CBT trials for chronic pain (Eccleston et al., 2014), and featured content tailored for the Singapore population. Firstly, all treatment was delivered in English. Treatment modules were arranged according to the three response style dyads of 'open' (defusion and acceptance), 'connected' (present moment awareness and self as context) and 'engaged' (values and committed action) (Hayes et al., 2012) to form a total of three modules. Each module comprised of two sessions each for a total of six sessions which reflected the six processes of ACT.

Again, iACT-CEL was designed as a combination of a face-to-face and internet-delivered intervention. The choice to include the face-to-face sessions, in addition to following participant preferences, was to simulate the experience of a fully face-to-face treatment, to promote an appropriate therapeutic relationship between patient and provider, and by doing so to promote engagement (Yang et al., 2015). Treatment material included experiential exercises, metaphors and mindfulness exercises delivered via a mix of audios, videos, animations and text. Videos and animations of ACT experiential exercises and animations are currently available as treatment tools, but have not been used together with audios and text in a complete program. Including the different modes of treatment delivery especially video based delivery, again catered to the preferences of people with chronic pain as informed by the results of our earlier study (Yang et al., 2016c), and also allowed the program to be as interactive as possible. The abilities for participants to engage in interactive text-based exercises online and to communicate with the therapist

via e-mail were also important treatment features. These treatment features allowed the therapist to respond to individuals in a way that was sensitive to their individual needs, to the verbal and direct environmental influences that have maintained maladaptive behaviour patterns, and thus allowed individual tailoring of the treatment.

Sessions were arranged such that they could be completed within a week with no restrictions on revisiting completed sessions or segments of each session. Therapist support was predominantly provided via e-mail with added phone support made available to participants as needed.

For the purposes of enhancing self-monitoring, clarifying the agenda or focus of treatment and promoting awareness of change, a set of diary ratings was used at the end of every module. Participants rated the following on a scale of 0-10 where '0' = not at all and '10' = completely. The ratings obtained were meant to guide treatment and were examined solely for this purpose.

- (a) How much did you struggle with pain this week?
- (b) How much did you open up to pain and distress and simply allow them to be there?
- (c) To what extent were you "living in the present" rather than focusing on your thoughts, the past or future?
- (d) How often did you follow your goals and values?

10.7 Cultural Adaptation of ACT Methods for iACT-CEL

Treatment adaptations made on iACT-CEL included recommendations made by Woidneck and colleagues (2014).

Language

Adapting ACT methods to the Singapore population required first a basic understanding of the history, language and culture of this population. This unique Singaporean background and identity already highlighted in Chapter 5.

In modifying ACT methods, the knowledge of Singaporean culture was applied in the delivery of treatment. A modification of language and the use of culture specific examples formed the main modifications of ACT methods for iACT-CEL. So although the treatment was delivered in English, sentence structure, choice of words and examples used to illustrate an ACT process, and general style of speech incorporated a Singaporean quality. The therapist delivering treatment is a Singaporean Chinese and although a treatment protocol with ACT methods was followed, the therapist naturally delivered both the face-to-face interactions and video content, which included culture specific examples, in a fashion that Singaporeans will find familiar.

Videos, Audios, Animations

Where possible, characters used in the animations tried to encompass the four main communities in Singapore with backdrops selected to provide a more realistic reflection of Singapore society and daily life. Consistent with the aim of ACT treatment to improve general performances in daily life, the setting for the video recordings was not at a clinic but rather a home setting.

Content Layout

Treatment content was laid out in a way such that previously delivered material was reinforced in each subsequent session to aid learning and integration. A mix of video, audio, and text-based exercises was used so that participants would experience a variety of modes of delivery, and this also reduced costs. An additional five optional mindfulness based exercises and

'Observing the breath' exercise were delivered via audio for reason of portability, that participants would be able to practice them anywhere and at any time.

10.8 Description of Internet-delivered Acceptance and Commitment Therapy – Connect Engage Live (iACT-CEL)

iACT-CEL was designed as a five-week combination of face-to-face and online ACT-based treatment delivery program. This program for chronic pain aimed to increase daily functioning and reduce pain interference with daily activities.

Technical Aspects of the Program

Development of the technical aspects of the program were divided into the following stages: (a) selection of web platform for the program, (b) security systems, (c) design and layout of webpages, (d) video and audio taping of treatment material, (e) designing the storyboard for the animations, (f) designing and construction of animations on web portal www.goanimate.com, (g) editing of video and audio material, (h) uploading of treatment materials, (i) preliminary testing of iACT-CEL, (j) informal presentation and feedback session from health professionals and selected patients at the clinic, (k) program editing, (l) live pilot testing of finalised program. A total of six months was spent to develop the final version of the iACT-CEL program.

The assistance of a web company to develop the internet interface of the program and a media company to develop the videos, audios and animations were sought. Appendix F provides a detailed description of the design and system used for the technological platform including the design of the administrator panel for treatment related data collection. Appendix G provides a

step-by-step guide to navigate the program. Figure 10.1, Figure 10.2 and Figure 10.3 depict the development process.

Figure 10.1: Home Page Design

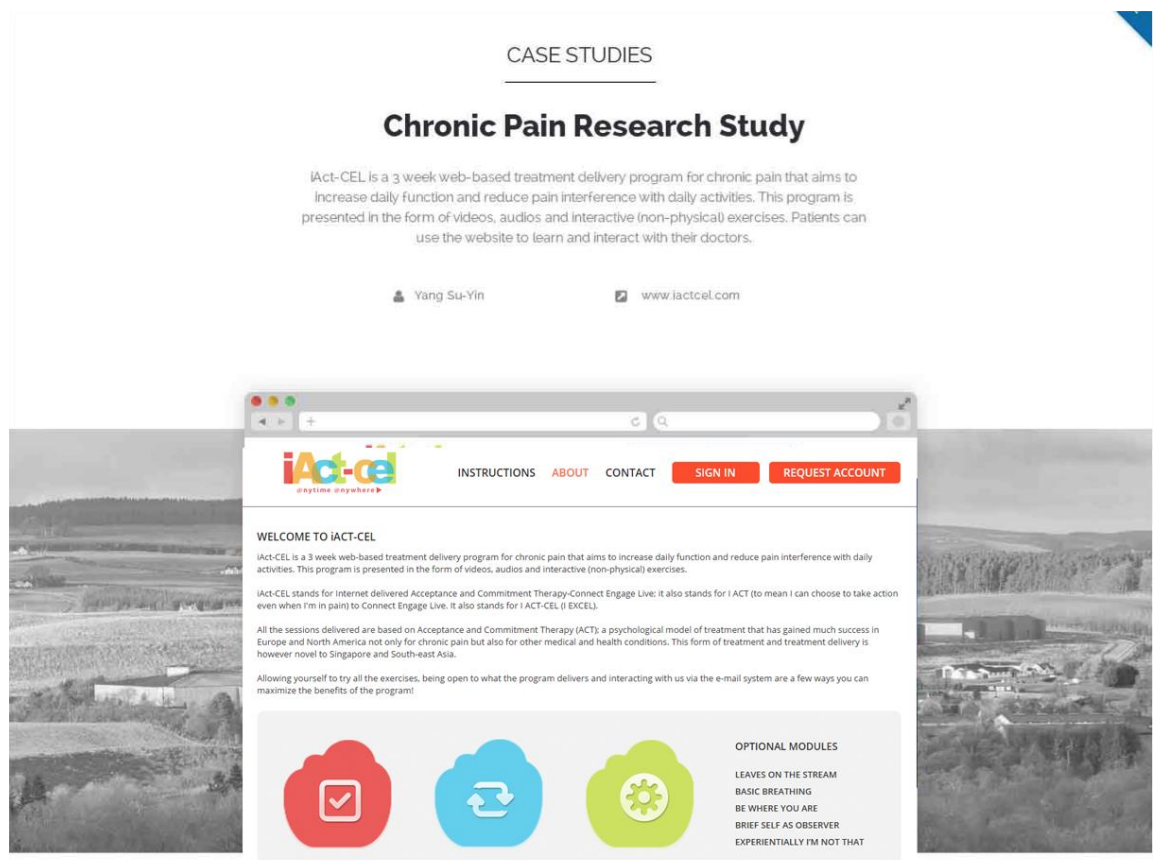

Figure 10.2: Design of Interactive Elements of iACT-CEL

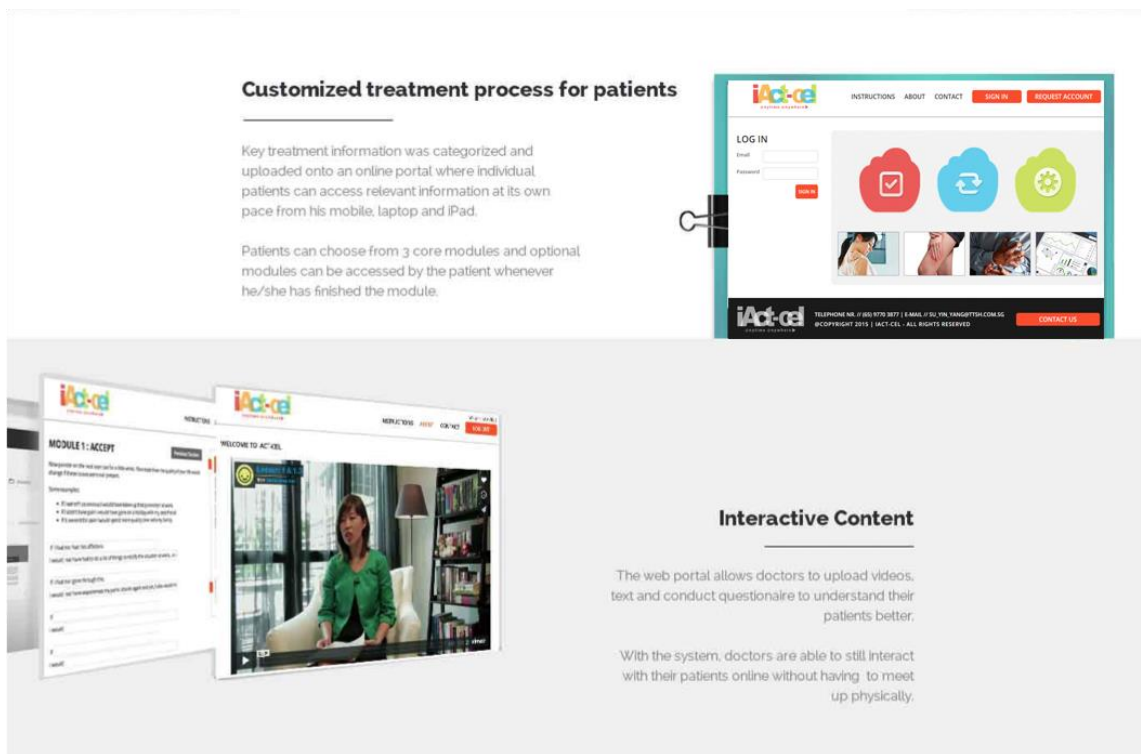
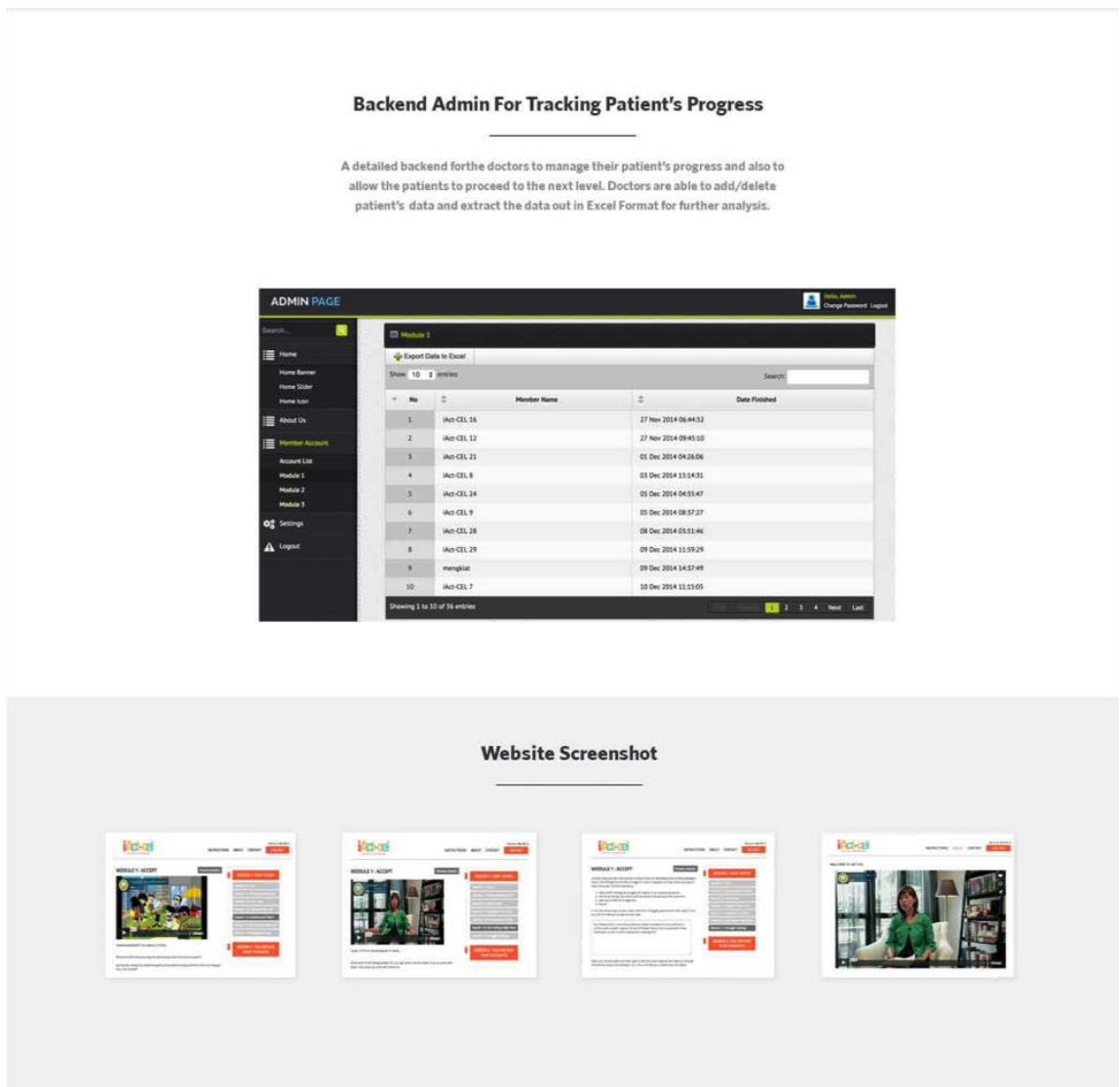

Figure 10.3: Design of Administrator panel



Video and Audio Material

A total of 20 hours was spent on recording a series of video material for the iACT-CEL program. Hi-definition videos with a video mode of 1080, 2073, 600 pixels per image, with a frame size of 1920 x 1080 and a frame rate of 30-60Hz were produced. Apple's Final Cut Pro (Professional) software was used in the editing process. A total of 31 videos, four animations and seven audio clips were created for the iACT-CEL program.

Administrator Panel

An administrator control panel was set up in a separate system to allow the therapist to have control over providing participants with appropriate access to the next module. Through this panel, the therapist was able to receive responses and questions provided by the participants as they engaged on the program. This also included responses on the diary ratings. Following participants' inputs, the therapist was able to engage and tailor responses appropriate to each individual participant. The setup of the administrator system allowed the therapist to track the date and time when participants logged on to start or continue with a session but not the time participants spent on each session. Participants received an e-mail reminder and encouragement to continue on the program if they were observed to have a time lag of more than 24hrs from the last log in. The administrator panel served as an invaluable tool that aided in treatment delivery.

10.9 Treatment Content

Much of the treatment content was based on or adapted from the following resources:

- (a) Learning ACT (Luoma et al., 2007)
- (b) The big book of ACT metaphors (Stoddard & Afari, 2014)
- (c) ACT made simple (Harris, 2009)
- (d) Get out of your mind and into your life (Hayes, 2005)
- (e) The happiness trap pocketbook (Harris & Aisbett, 2013)
- (f) A beginner's guide to mindfulness (Bohlmeijer & Hulsbergen, 2013)

A condensed version of the treatment protocol is included in Appendix H.

Face- to-Face Sessions

Session 1: Chinese Finger Trap Exercise

The first face-to-face session aimed to build rapport, develop a shared understanding of the nature of the pain problem, and introduce participants to the concept of experiential avoidance. The experiential exercise known as “The Chinese Finger Trap” was demonstrated to participants (see Appendix H for details).

Following the situations that were identified, participants set goals following the SMART principles of Specific, Meaningful, Achievable, Realistic and Time-based in a pen and paper exercise. These goals were to be ideally achieved by the next face-to-face session at the end of the program.

Final Face-to-Face Session: Generalised Committed Action

The final face-to-face session expands from the last session on committed action delivered on the online program. The focus of the session was to address barriers and have participants maintain committed action on goals that they set for themselves (see Appendix H for details). Following an agreed plan, participants complete a pen and paper goals and barriers exercise, helping them move in a step-by-step fashion towards their goals, identify psychological and practical barriers of the chosen goals and the strategies to overcome these barriers. The therapist ends the session by summarising the main discussion points in the session that are specific to each participant.

Online Sessions

The web address: **www.iactcel.com** was created as the home page for the iACT-CEL program. Again, the program consists of a total of three modules incorporating the six processes of ACT with Module 1 (Accept) introducing ‘acceptance’ and ‘cognitive defusion’, Module 2 (Connect) introducing ‘present moment awareness’ and ‘self as context’ and Module 3 (Engage) introducing ‘values’ and ‘committed action’. In addition to the core sessions there are also

optional exercise, although these do not include the need to submit responses of assignments.

Module 1-ACCEPT

Module 1 broadly focused on building acceptance and openness with elements of cognitive defusion. The therapist introduced to participants that openness includes a focus on experiences that are uncomfortable, or painful, experiences that we do not like and a way to make room for them to be “present” in our experience, explicitly when to do so allows us to achieve what we want out of life.

Session 1: The Problem with Avoidance

In session 1, participants were asked to examine experiences that they have been struggling with, results of those struggles, and how well they are living as they want to do. All exercises and metaphors in this session were arranged to encourage participants to consider stopping the struggle for control over pain and distress with willingness suggested as an alternative. The participant experienced the qualities of willingness through the exercises and is aided to make contact with the cost of unwillingness.

Session 2: More on Openness and ‘You are not your thoughts’

In this session, participants were introduced to the concept of ‘Acceptance’. Acceptance was presented as an active, positive embracing of life, a way of saying ‘yes’ to life as a whole and not a passive acceptance of it. Following on from Session 1, willingness in action was emphasised again here with the therapist helping participants to identify their emotional, cognitive, behavioural and physical barriers to willingness. Metaphors (the struggle switch, passengers on the bus) were used to create a separation between participants and their conceptualised experience. The “expansion exercise” helped

participants to experience opening up, building willingness, and making space for difficult private experiences. Diary ratings were collected at the end of the session. Table 10-1 provides a schematic overview of the core treatment content in session 1.

Table 10-1: Core Treatment Content in Module 1

Module 1 (ACCEPT)	
Session 1	Session 2
The Problem with avoidance	More on openness and you are not your thoughts
Video and text: Pain avoidance cycle	Video and text: Struggle Switch
Animation: Tug of War metaphor	Animation and text: Passengers on the Bus
Text: How I cope?	Experiential exercise: Expansion exercise
Text: Evaluation of avoidance strategies	Text: Acceptance in action
Animation and text: Joe the Bum	FAQs
Experiential exercise: Connect, breathe, open up	Weekly ratings
Text: Reflect on current feelings and to notice occasions of struggling in the week	

Module 2 - CONNECT

Module 2 broadly focused on building awareness of thoughts, present moment awareness and self as context. Sessions in this module helped participants to focus on the happenings in the here and now and not in the past or the future. Elements of acceptance and cognitive defusion from Module 1 were also further developed here.

Session 1: I accept

The aim of this session was to build up the ability to deal more successfully with “the mind” in the present and the thoughts it produces. In this session, through experiential, mindfulness-based, and text-based exercises, participants were guided through a process of increasing their awareness of thoughts that link with the past or future and reconnecting to the present when they notice that they have lost their connection to it.

Session 2: In the present moment

In this session, attention to the present moment is further emphasised and the process of self-as context was introduced. The therapist helped participants to make contact with a sense of self as an observer and learn to differentiate this sense of self from the content of their experiences such as thoughts, emotions, memories and sensations. The use of experiential exercises and metaphors (e.g. The observing self, The chessboard) helped participants to notice the working of the mind and emotional responses while also contacting a self who chooses and acts with these experiences. Diary ratings were collected at the end of the session. Table 10-2 provides an overview of the core treatment content developed in Module 2.

Table 10-2: Core Treatment Content in Module 2

Module 2: Connect	
Session 1	Session 2
I accept	In the present moment
Video: Don't think of a durian	Experiential exercise: Anchoring
Text: What are you thinking right now ?	Video: Stop and think
Video and text: I'm having the thought That	Experiential exercise: Notice 5 Things
Experiential exercise: Awareness of your experience	Experiential exercise: Observing the Breath
Video: Encourage continued engagement in program	Video and text: The Chessboard
	Video: The Observing Self
	Weekly ratings

Module 3- ENGAGE

Module 3 focused on helping participants identify important areas of life that matter and to commit to taking action towards achieving or moving in one's chosen valued direction.

Session 1: What do you want out of life?

This session focused on values and building on engagement skills. The importance of values and its use in giving direction for making meaningful choices was introduced. Values and goals were distinguished and participants encouraged to be involved in the process of living and not just on symptom reduction. The session starts with "Get off your butts" exercise, reiterating how language can be a barrier to progress. Subsequent metaphors, experiential

exercises and interactive online exercises focused predominantly on values clarification and the workability of values in moving the person towards a meaningful life.

Session 2: Committed Action

This session introduced the concept of 'committed action' as part of building up 'engaged' skills. Main aims of the session centred on getting participants to identify relevant high-priority values domains, develop goals in line with these values, to then follow these values and act on these goals. The therapist acknowledged and made space for relapses and integrated this into the process of keeping commitments and building more effective patterns of action. All metaphors and interactive text based exercises contributed to this process. Diary ratings were collected at the end of the session. Table 10-3 provides an overview of the core treatment content developed for module 3.

Table 10-3: Core Treatment Content in Module 3

Module 3: Engage	
Session 1 What do you want out of life?	Session 2 Committed Action
Video and text: Get off your Buts	Video: The Swamp metaphor
Video and text: Values clarification exercise	Text: Goal setting
Video and text: My life's motto	Video: Committed Action
Animation and text: 80 th Birthday	Text: Willingness and action plan
Video: Encouragement to continue with program	Text: From FEAR to DARE
	Video and text: The Tour Guide
	Weekly ratings

Optional Exercises

Optional exercises focused mostly on openness and awareness skills with experiential exercises delivered in the form of audio files. There was no specific order to the selection of these exercises but simply to include more common ones that reflected these processes within ACT: being present, acceptance, defusion and self as context (Luoma et al., 2007) that have not already been included in the main program. Participants were encouraged to practice the optional exercises at least once. The following exercises were included in the optional module section of the program:

- (a) Leaves on the stream exercise
- (b) Basic breathing-based mindfulness exercise
- (c) Be where you are
- (d) Brief self-as-observer exercise
- (e) Experientially “I’m not that” exercise

10.10 Chapter Summary

This chapter described the development of the iACT-CEL program, which is the first prototype of an online ACT-based treatment for chronic pain designed for delivery in Singapore and Southeast Asia. The program incorporated treatment content from published treatment resources from the ACT literature with culture specific modifications made to adapt ACT methods for a Singapore chronic pain population. A summary description of each session is provided, with further details on the technical aspects of the program, step-by-step instructions to navigate the program as well as a condensed version of the iACT-CEL treatment protocol, which included detailed descriptions of each treatment session, in the appendices. A feasibility trial, testing aspects of the iACT-CEL program is described in the next chapter.

Chapter 11: iACT-CEL: A Feasibility Trial of a Face-to-Face and Internet-based Acceptance and Commitment Therapy (ACT) Intervention for Chronic Pain in Singapore

11.1 Chapter Overview

This chapter describes a test of the feasibility of elements of the iACT-CEL program (described in Chapter 10) in a small sample of chronic pain patients in Singapore. It includes (a) aims of the study (b) rationale for the choice of a feasibility study design (c) methods used to evaluate the iACT-CEL program (d) key findings and (e) an overall discussion of the study. A modified version of this chapter incorporating descriptions of the treatment content and intervention is currently under review for publication.

ACT has been recognised as a legitimate treatment alternative to CBT for people with chronic pain (Hann & McCracken, 2014). Internet-delivered ACT-based interventions for chronic pain have demonstrated significant reductions for pain related distress, anxiety and depression (Buhrman et al., 2013), pain interference, disability and catastrophising (Trompetter et al., 2015a), at six months follow-up in the ACT intervention.

The use of technology as part of treatment delivery has been suggested in previous work (Yang et al., 2015, 2016b) as a means to increase psychological treatment uptake for chronic pain in Singapore. As already mentioned in Chapter 5, Singapore is ranked globally as a technologically savvy country with local statistics indicating a high usage of the internet (IDA). As such, tailoring an internet-based ACT treatment for chronic pain, designing it in a form that is culturally sensitive, and testing this approach as part of a feasibility trial in Singapore, appears worthwhile.

11.2 Study Aims

This study aimed to develop an adaptation of an ACT-based treatment that is suitable for people with chronic pain in Singapore, and to test the feasibility of the program delivered partly through an internet-based platform. Assessment here included recruitment, retention, treatment expectations, acceptability and satisfaction, and standard clinical outcomes of pain interference, satisfaction with life, pain intensity, depression and impact of depression. It was predicted that the required recruitment target (N = 30) would be reached within a 3-month recruitment period, and that the majority of participants would complete the modules, assessments, and report satisfaction with the experience. Although the trial was not powered to detect significant

effects on outcomes, potentially clinically meaningful changes in outcomes for a majority of participants were expected.

11.3 Methods

This study was approved by the Domain Specific Review Board (DSRB: 2014/00641), the local ethics committee in Singapore. All participants provided informed consent to participate in this study.

Design

This was an uncontrolled pre-post study design. Treatment outcomes were measured online via self-report instruments at three time points: (a) baseline (b) immediately post-treatment and (c) at 3-months follow-up.

While the use of RCT designs for internet-based trials was recommended in a recent Cochrane review (Eccleston et al., 2014), this was not done here for several reasons. The primary focus here was feasibility questions. Also, resource and ethical considerations placed restrictions on what could be done. The pre-post design meant that greater attention could be afforded to treatment design and delivery, consistent with preferences observed in previous research in the same setting (Yang et al., 2016c). This research is described in Chapter 9. Thus, iACT-CEL was designed as a combination of a face-to-face and internet-delivered intervention.

Participants

Participants were recruited from the pain management clinic (PMC) at Tan Tock Seng Hospital in Singapore and via the PMC website. Participants were included if they were (a) above the age of 21 years old (b) diagnosed with chronic non-cancer pain for more than 3-months (c) competent in English (d) able to access and use the internet and e-mail (e) not currently or previously

involved in a structured approach to CBT for chronic pain in the last one year, and (f) approved by their primary doctor to take part in the study.

Participants were excluded if they (a) had a cognitive impairment or (b) were diagnosed with mental illness or health problems expected to significantly interfere with study participation, or (c) were currently pregnant.

All participants recruited at the PMC were first screened by their attending primary health professional for eligibility to participate (see Appendix I for participant study invite, Appendix J for study information sheet for health professionals and Appendix K for participant consent form). Other participants were screened for eligibility by a psychology intern at the PMC.

Intervention

The therapist who conducted the intervention held a masters level health psychology degree with ten years of experience providing treatment for people with chronic pain. She received fortnightly supervision from an experienced senior clinical psychologist.

Participants completed a total of two face-to-face and six online sessions over a period of 5 weeks. Details of the intervention are described in chapter 10. A minimum time of 45 minutes was needed to complete a session in one sitting, similar to time spent in a face-to-face session.

All communication within the program was handled within a secure encrypted system. Participant numbers were used in all communication. A user database was created to store participants' last logged in information. E-mail interactions initiated by the therapist followed a structured response that included (a) encouragement of participants' progress and motivation to continue with the intervention, (b) clarification of unclear aspects of the intervention, and (c) answering participants' questions. The therapist also responded to separate

queries from participants made via e-mail within 24hrs of receipt. An alternative form of backup communication was also provided via a contact number provided on the program.

Participants continued with treatment as usual including medical visits and physiotherapy treatments but did not seek other psychology related treatments while on the program. Table 11-1 summarises the study schedule.

Table 11-1: Summary of Study Schedule

Week 0	Week 1	Week 2	Week 3	Week 4	Week 5 + 3 months follow-up
Participants received study information, and provided informed consent.	Completed first face to face session with the therapist.	Participants completed sessions 1 and 2 on the online program.	Participants completed sessions 3 and 4 on the online program.	Participants completed sessions 5 and 6 on the online program.	Participants completed the final face to face session with the therapist.
Received a unique username and password to log on to the online program and to a separate secure e-mail account created for the purposes of this study.	Participants learnt to navigate through the online program and received instructions regarding participant-therapist communication on the program.	Completed a set of diary ratings on a scale of 0-10 rating their level of struggling versus openness to pain at the end of week 2-4. Ratings used for treatment purposes only.		Participants were contacted via e-mail to schedule the final face to face session with the therapist.	Participants received an e-mail link to complete a set of post-treatment questionnaires online at week 5 and a similar set of follow-up questionnaires at 3-months follow-up.
Received an e-mail link to complete a set of baseline questionnaires online	Received an e-mail link to the welcome page of the online program (www.iactcel.com).	Access to the next session is given upon satisfactory completion of the previous one.			
A first face to face session with the therapist was scheduled via e-mail and a follow-up phone call.		Access to 5 optional online audio exercises from week 2 to week 4.			

Measures

Healthcare Usage

Healthcare use was assessed with a 4-item measure of pain-related medical visits over the past 3 months, including number of doctors seen,

number of doctor visits, visits to the accident and emergency care (A & E) and number of days hospitalised.

Survey on Treatment Expectations, Program Acceptability and Satisfaction.

Treatment expectations (see Appendix L), program acceptability and treatment satisfaction (see Appendix M) were measured by single items that were not part of a validated scale. Items measuring treatment expectations and program acceptability were adapted from Borkovec and Nau's (1972) treatment credibility and expectancy questionnaire.

Primary Outcomes

The Brief Pain Inventory (BPI) – interference scale (description provided in Chapter 9, p. 220) and Satisfaction with Life Scale were used to measure primary outcomes of pain interference and life satisfaction respectively. The Satisfaction with Life Scale (SWLS) is a 7-item measure of global life satisfaction (see Appendix N). The scale has adequate internal consistency ($\alpha = 0.87$) and a test-re-test reliability correlation co-efficient of $r = 0.82$ (Diener et al., 1985)

Secondary Outcomes

A numerical pain rating scale and the PHQ-9 were used to measure secondary outcomes. The PHQ-9 was used as a measure of depression and impact of depression. Descriptions of these measures are provided in Chapter 9, pp. 220-221.

Measures of Psychological Flexibility

Measures of PF were included to determine any changes on these potential therapeutic mechanisms. The CPAQ-8 (Fish et al., 2010), AAQ-II (Bond et al., 2011) and the CAQ (McCracken, 2013) were used (descriptions of these measures provided in Chapter 9, pp. 221-222).

Data Analysis

Independent samples t-test were used to calculate baseline differences between treatment completers and non-completers. Survey data on treatment expectation, program acceptability and treatment satisfaction were presented descriptively. Participants were regarded to have completed the program only if they had completed all six online sessions, allowing a minimal exposure to the six core processes in ACT. Outcome and process variables were analysed using the intention to treat (ITT) principle. Multiple imputation analysis on SPSS IBM Statistics 21 package was conducted. There was one missing value on the SWLS at baseline. The total missing data at post-treatment and follow-up was 9.1%. These missing values were imputed. Paired samples t-tests were used to analyse differences at the three assessment time points and Cohen's *d* (Cohen, 1988) was used to calculate effect sizes between these assessment time points. A pooled SD was used in these calculations.

IMMPACT recommendations including the convention of using $\frac{1}{2}$ SD to calculate clinically meaningful change was followed (Dworkin et al., 2005). The proportion of participants showing clinically meaningful change in the clinical direction was then calculated.

11.4 Results

Figure 11.1 shows the flow of the study.

Figure 11.1: Study Flow Diagram

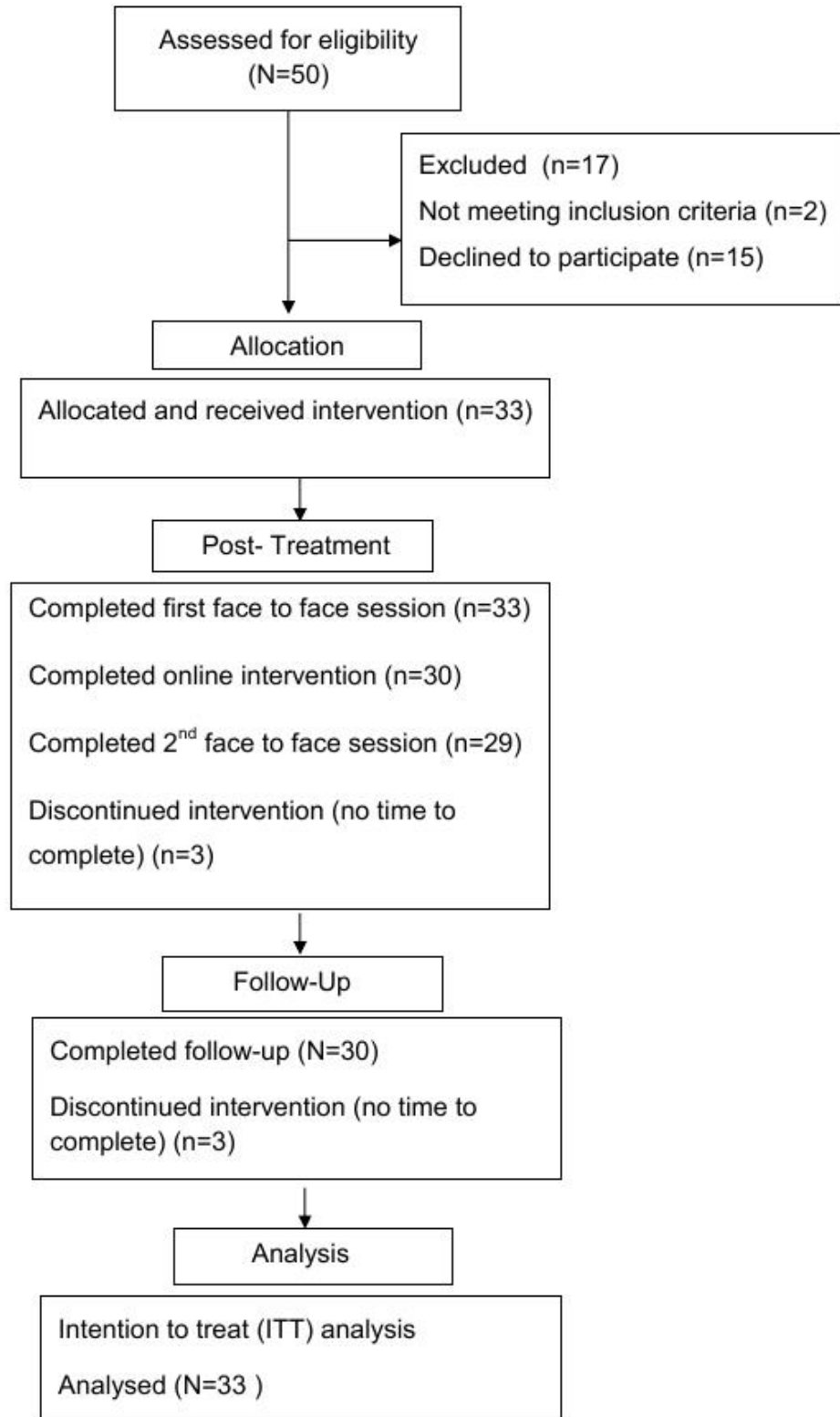

A total of 64.6% participants who were recruited via the PMC took up treatment. Participants who declined participation cited a lack of interest and time commitments as reasons. Treatment uptake rates for recruitment via the PMC website are not reported as there were limited means to track the total number of people that accessed the website. A total of 90.9% of participants who provided informed consent completed the intervention and provided follow-up data. A majority of participants (78.8%) were suffering from primary low back pain. A total of 81.8% of participants were seeking specialist treatment, 63.6% were on medication, and 69.7% had undergone physiotherapy. Table 11-2 summarises participants' demographics and healthcare usage.

Table 11-2: Participants' Demographics

		Mean (SD)
Age		47.61 (12.63)
Years of education		13.61 (2.93)
Pain Duration		111.39 (91.79)
Medical leave days		21.64 (66.76)
No. of doctors seen		3.00 (2.13)
No. of doctor visits		2.39 (2.05)
No. of A & E visits		0.00 (0.00)
		No. of participants (%)
Sex	Male	8 (24.2)
	Female	25 (75.8)
Race	Chinese	22 (66.7)
	Malay	4 (12.1)
	Indian	2 (6.1)
	Others	5 (15.2)
Marital	Married	11 (33.3)
	Divorced	4 (12.1)
	Single	18 (54.5)
Housing	Lives with spouse and children	11 (33.3)
	Lives with parents	13 (39.4)
	Lives alone	3 (9.1)
	Other	2 (6.1)
Work Status	Full Time	18 (54.5)
	Part-Time	5 (15.2)
	Others	10 (30.4)

Treatment completers (n = 30) and non-completers (n = 3) did not differ on demographic variables and healthcare usage at baseline. However non-completers demonstrated a significantly higher impact of depression, $t(31) = 2.14$, $p = 0.04$ and lower pain acceptance, $t(31) = -2.52$, $p = 0.02$.

Treatment Expectations, Program Acceptability and Satisfaction

Participants had expected a reduction of 60.3% in limitations due to pain as a result of program participation, but only a 44.7% reduction in limitations at post-treatment was reported. A reduction of 30.2% in limitations due to pain was maintained at follow-up. Table 11-3 summarises participants' treatment expectations.

Table 11-3: Summary of Pre-and Post-Treatment Expectations

	Not at all (%)	A little (%)	Reasonably (%)	Strongly (%)	Very Strongly (%)
Program can help to manage Pain	0 (0.0)	7 (21.2)	15 (45.5)	9 (27.3)	2 (6.1)
	Extremely unsuccessful (%)	Unsuccessful (%)	Neutral (%)	Successful (%)	Extremely successful (%)
Expectation of program success at reducing limitations	0 (0.0)	1 (3.0)	10 (30.3)	20 (60.6)	2 (6.1)
	Highly unmet (%)	Unmet (%)	Neither met nor unmet (%)	Met (%)	Highly met (%)
Post-treatment expectations	0 (0.0)	1 (3.3)	7 (21.2)	18 (54.5)	4 (12.1)
	Extremely unsuccessful (%)	Unsuccessful (%)	Neutral (%)	Successful (%)	Extremely successful (%)
Program success in reducing limitations	0 (0.0)	3 (9.1)	13 (39.4)	14 (42.4)	0 (0.0)

On measures of program acceptability, responses of 'agree' and 'strongly agree' were combined to represent 'agree' while responses of 'disagree' and

'strongly disagree' were combined to represent 'disagree'. Table 11-4 summarises the responses of participants on program acceptability and treatment satisfaction. Overall program was acceptable to the majority of participants, 81.8% of participants were generally satisfied with overall treatment. 51.5% continued to access the program and 75.8% continued to practice the strategies at follow-up.

Table 11-4: Summary of Participants' Responses on Program Acceptability and Treatment Satisfaction

Treatment Acceptability (N =30)	Disagree (%)	Neither agree nor disagree (%)	Agree (%)
Information on the program was easy to understand	1 (3.0)	6 (18.2)	23 (69.7)
Information was personally Relevant	1 (3.0)	3 (9.1)	26 (78.8)
Program was easy to use	1 (3.0)	4 (12.1)	25 (75.8)
Interactive exercises were helpful	1 (3.0)	4 (12.1)	25 (75.7)
Ability to communicate to the therapist via e-mail was important	0 (0.0)	14 (42.4)	16 (48.5)
Ability to apply techniques learnt in daily life	1 (3.0)	8 (24.2)	21 (63.6)
No technical difficulties were experienced	7 (21.2)	3 (9.1)	20 (60.6)
Duration of program was just right	3 (9.1)	1 (3.0)	26 (78.8)
Program likely to help people with chronic pain manage more effectively	1 (3.0)	6 (18.2)	23 (69.7)

Treatment Satisfaction (N=30)	Extremely Unsatisfied (%)	Unsatisfied (%)	Neutral (%)	Satisfied (%)	Extremely Satisfied (%)
Therapist s response time	0 (0.0)	0 (0.0)	7 (21.2)	12 (36.4)	11(33.3)
Quality of interaction with therapist	0 (0.0)	0 (0.0)	3 (9.1)	18 (54.5)	9 (27.3)
Online program	0 (0.0)	0 (0.0)	6 (18.2)	17 (51.5)	7 (21.2)
Total treatment (including face-to-face sessions)	0 (0.0)	0 (0.0)	3 (9.1)	18 (54.5)	9 (27.3)

An average of 15.6 e-mail correspondences transpired between the therapist and each participant during the course of the online program, including a minimum of eight e-mails initiated from the therapist, typically at the start of each session, at program completion and at follow-up. Calls received by the therapist from 30% of participants included a mix of technical related issues and

clarification of general issues pertaining to the program. None of the calls required any extra therapeutic intervention in addition to the program itself.

Outcomes and Effect Sizes

Table 11-5 summarises the means (M) and standard deviations (SD) obtained at the three assessment time points for all outcomes and PF. Significant improvements in depression at post treatment, $t = 3.08$, $p = 0.002$, and follow-up, $t = 3.28$, $p = 0.001$, and for pain intensity at follow-up, $t = 2.15$, $p = 0.03$ were demonstrated. All other outcomes showed no significant change.

Table 11-5 Means and Standard Deviations for Outcomes and Process

Measures

	Baseline Mean (SD)	Post-Treatment Mean (SD)	Follow-Up Mean (SD)
Pain Interference	4.50 (2.81)	3.90 (2.60)	3.91 (2.37)
Satisfaction with life	18.41 (8.25)	20.30 (8.85)	19.18 (10.33)
Pain intensity	5.29 (2.70)	4.90 (2.72)	4.37 (2.37)
Depression	11.15 (6.31)	8.14 (5.54)	8.86 (5.91)
Impact of Depression	0.91 (0.67)	0.67 (0.67)	0.79 (0.58)
Pain Acceptance	25.21(6.93)	25.92 (9.53)	25.44 (9.60)
General Acceptance	26.36 (9.90)	26.13 (10.91)	25.68 (13.83)
Committed Action	65.73 (17.00)	66.82 (17.47)	64.95 (19.63)

Minimal to small effect sizes ($d = 0.14$ to 0.35) were obtained for all outcomes except for a medium effect size for depression ($d = 0.51$). Minimal effect sizes ($d = 0.02$ to 0.09) were obtained for all PF measures. Table 11-6

summarises the mean differences and effect sizes at the three assessment time points.

Table 11-6: Mean Differences and Effect Sizes for Baseline to Post-treatment and Baseline to Follow-up

	Baseline to Post-Treatment (t-test)	Cohen's <i>d</i>	Baseline to Follow-up (t-test)	Cohen's <i>d</i>
Pain Interference	t = 1.17, p = 0.24	0.22	t = 1.59, p = 0.11	0.22
Satisfaction with life	t = -0.70, p = 0.49	0.22	t = -0.27, p = 0.79	0.09
Pain intensity	t = 0.90, p = 0.37	0.14	t = 2.15, p = 0.03	0.34
Depression	t = 3.08, p = 0.002	0.51	t = 3.28, p = 0.001	0.39
Impact of Depression	t = 1.95, p = 0.06	0.35	t = 0.98, p = 0.33	0.18
Pain acceptance	t = -0.30, p = 0.77	0.09	t = -0.10, p = 0.92	0.03
General acceptance	t = 0.17, p = 0.87	0.02	t = 0.29, p = 0.78	0.07
Committed action	t = -0.34, p = 0.73	0.06	t = 0.14, p = 0.89	0.05

Clinically Meaningful Change

Meaningful change outcomes were generally consistent from post-treatment to follow-up therefore only follow-up results are reported. Clinically meaningful improvement in at least one outcome (out of five total) was demonstrated in 75.8% of participants, 57.6% made clinically meaningful improvements on at least 2 outcomes, 30.3% on at least 3 outcomes, 18.2% on at least 4 outcomes and 3.0% on all 5 outcomes. Of those that did not report meaningful improvement, a significant proportion showed no change, 36.4% (satisfaction with life and pain intensity) to 57.6% (impact of depression). A

small proportion of participants reported meaningful decline, predominantly a decline in satisfaction with life (24.2%). Table 11-7 shows the proportions of participants who meaningfully improved, showed no change, and declined.

Table 11-7 Proportions of Participants who made Clinically Meaningful Improvements, showed No Change and Declined

(N = 33)	Improved (%)		No Change (%)		Declined (%)	
	Post Treatment	F/U	Post Treatment	F/U	Post Treatment	F/U
Pain Interference	11 (33.3)	10 (30.3)	17 (51.5)	17 (51.5)	5 (15.2)	6 (18.2)
Satisfaction with Life	13 (39.4)	13 (39.4)	11 (33.3)	12 (36.4)	9 (27.3)	8 (24.2)
Pain Intensity	14 (42.4)	15 (45.5)	7 (21.0)	12 (36.4)	12 (36.4)	6 (18.2)
Depression	12 (36.4)	15 (45.5)	18 (54.5)	16 (48.5)	3 (9.0)	2 (6.0)
Impact of Depression	8 (24.3)	9 (27.3)	24 (72.7)	19 (57.6)	1 (3.0)	5 (15.2)

F/U; Follow-Up

11.5 Discussion

Successful recruitment, low drop-out rates, high ratings of overall program acceptability and satisfaction, and significant small effects on depression and pain intensity at 3-months follow-up, support the potential feasibility of an ACT-based, combined face-to-face and internet-delivered treatment for people with chronic pain in Singapore.

Results demonstrated that a moderately high percentage of participants (66.7%) had their treatment expectations met. This possibly implied that pre-treatment expectations of this study sample matched the purpose of the program. Pre-treatment expectations have been shown to predict treatment

outcome of CBT interventions in a group of chronic pain patients (Goossens et al., 2005). The size of this study did not allow for such analyses.

In reviews of internet-based trials, it is apparent that higher dropout rates coincide with trials that include the lowest level of therapist contact (Cuijpers et al., 2008; Macea et al., 2014). The added therapist contact time with the inclusion of face-to-face sessions, could have contributed to lower dropout rates in this study. The assurance of a quick response from the therapist may have further contributed to the positive effects observed. This low attrition rate indicates good feasibility for a future larger scale study.

Unlike previous studies (Buhrman et al., 2013; McCracken, 2013), a significant increase in pain acceptance was not found in this sample. Based on the current results, the intervention was most effective in reducing depression. It has already been demonstrated that internet-based ACT can reduce depression (Buhrman et al., 2013; Lappalainen et al., 2014), and the results here add to previous findings.

It was interesting to observe significant pain reduction in this sample although this was not a primary focus of treatment. When this happens in ACT treatment, it is likely the result of a process in which chronic pain sufferers continue to engage in meaningful activities, struggle less to control pain such that the impacts of pain and distress are significantly reduced over time (McCracken et al., 1999, 2004). The small sample size here however limited the power to detect effects and to test potential mediators.

Overall, results demonstrating clinically meaningful improvement across the treatment outcomes at follow-up are encouraging, 27.3% (impact of depression) to 45.5% (pain intensity and depression). A proportion of participants, for example 6% (depression) to 24.2% (satisfaction with life)

reported clinically meaningful decline at follow-up (in some cases these rates were higher immediately post-treatment). It is possible that these participants (a) were experiencing natural flare-ups in symptoms as a part of healthy engagement, (b) may have become more aware of their difficulties or more willing to report them, or (c) perhaps there were some unexpected adverse effects included in the treatment experience. Perhaps, those that declined did not respond as well to online treatment delivery and needed more intensive treatment for positive change to occur. Exploring these speculations, perhaps qualitatively, may contribute further understanding of this result.

Results did not support convincing improvements in pain interference nor satisfaction with life at any of the assessment time points. Non-significant findings with minimal effect sizes were also found here for all measures of PF. PF has been shown to be relevant for a chronic pain population in Singapore, with PF contributing significant variance to pain interference, depression and impact of depression beyond pain intensity (Yang et al., 2016c). Hence, this could mean that (a) the treatment content intended to target these variables may need to be delivered with higher intensity for change to occur, (b) other processes within PF could have shifted in treatment but these were not assessed, (c) the study lacked power to detect significant changes in these domains, or (d) perhaps there were some aspects of the population that were not taken into account in delivery. As the online delivery platform was a first generation prototype, some additional treatment development may be needed, and perhaps a better powered study, to further explore these speculations.

Optimal design of internet-based treatments for chronic pain is essential if it has to produce behaviour change outcomes that are similar to face-to-face treatments. This design will need to include optimal impact on components of

PF on outcome via features of the iACT-CEL program. This warrants considerations such as (a) the choice of metaphors and experiential exercises to include, (b) the optimal number of metaphors and experiential exercises and how to distribute them over time, (c) the number and length of each session, and (d) associated processes such as rapport and therapeutic alliance, may add further utility to future treatment design. Perhaps, a focus on developing more effective adaptations of culturally sensitive elements in the delivery of ACT-based treatment within the context of the intervention can be applied. Such elements may not have been designed and delivered optimally here. A more rigorous inclusion of (a) cultural appropriateness of language, (b) concordance between the therapist and patient (c) commonly understood concepts within the cultural group, and (d) specific knowledge of cultural uniqueness in treatment content (Bernal et al., 1995) may contribute to better treatment outcome. Recruiting participants with more severe pain, disability and distress and including a longer follow-up period of 6-months should also be considered for future studies.

Study Limitations

This study has a few limitations. Firstly, the study design did not allow for observed changes in outcomes to be attributed to the ACT-based treatment itself. The choice of an uncontrolled study design for the current study seemed most appropriate at this point for a feasibility trial of a never tested culturally adapted treatment with so many unknown elements.

Secondly, the sample size was small. A sample size of $N = 30$ has been recognised as a reasonable minimum sample size needed for parameter estimates of a larger RCT (Browne, 1995; Hertzog, 2008). So although the sample size of this study meets this minimum criterion set for a feasibility study,

the small sample size also implies limited statistical power and potentially limited reliability.

Participants were predominantly recruited from one specialist pain treatment clinic. Examining the reliability and generalisability of the present findings with a different and larger sample, including a longer follow up period may be needed.

Treatment content of the iACT-CEL program was intended to be culturally sensitive and adapted to the Singapore chronic pain population. However, it is difficult to assess whether the adapted aspects were optimal – this would require some comparison between differing versions of treatment, or applying a “gold standard” for “optimal.” Treatment-related competency and fidelity were also not formally assessed. The challenges of treatment optimisation and integrity remain a priority for future studies.

Conclusion

The current study of an ACT-based treatment, examined in the healthcare context of Singapore, showed that it appears feasible and potentially promising for future research and development. Future studies will need to consider more effective ways to target outcomes of pain interference, satisfaction with life and processes related to PF, which contrary to expectations did not demonstrate a convincing pattern of significant change here. There are features to consider in the future, such as number of sessions to include, frequency in the delivery of treatment content, choice of delivery modes, and tracking for time spent in treatment. Features that may potentially influence treatment outcome.

Chapter 12: General Discussion

This thesis represents a step-by-step account of the development of a psychological treatment for chronic pain in Singapore, where considerations of the culture and healthcare environment unique to Singapore were part of the research process. Sensitivity to the role of culture in relation to understanding the applicability and utility of ACT for people with chronic pain in Singapore formed a main focus. These steps culminated in providing support for the feasibility of developing an ACT-based treatment for chronic pain in this part of the world.

12.1 Summary of Key Findings

Because different cultural contexts create fundamental differences in how people from those cultures view the world around them, it is argued that not all people of Eastern or Asian origins will consider Western treatment approaches to be relevant in addressing their concerns (Hall et al., 2011). In particular, psychological treatment approaches. Many are not convinced that psychological treatment is a credible means by which to solve their problems (Sue & Zane, 1987). For this reason, and because little is known about the applicability of psychological treatments in Singapore, exploring the feasibility of developing a psychologically-based treatment for chronic pain in Singapore, a country that embraces a unique blend of Western and Eastern cultures is worthwhile.

Chapter 6 established that the extent and quality of evidence for psychological treatments for chronic pain in Southeast Asia is limited. There is a lack of RCTs, and a general lack of high quality studies. Those that have appeared had small sample sizes. Sampling from many different countries in East and Southeast Asia was required to gather enough studies to summarise

data, and relatively few of these were from Southeast Asia. Hence, the evidence base is vastly different here from the established evidence from RCTs from Europe and North America (Williams et al., 2012). The differences in results obtained here could perhaps be broadly explained by the differences in the cultural setting, healthcare environment and research priorities in this part of the world. Particularly, (a) differences inherent in healthcare systems and policies, (b) research-related infrastructure, (c) availability of funding and other related resources, and (d) availability of validated measures in the diverse languages commonly spoken in Southeast Asia, are potential factors influencing the viability of conducting effective research in countries in this region. Better designed studies are needed in Southeast Asia, including Singapore, to learn and then meet patients' needs, to persuade local stakeholders, and to better implement evidence-based treatments.

One main limitation in the review and synthesis of evidence for psychological treatments for chronic pain in East and Southeast Asia is the potential for publication bias. Studies may also have been missed because they were (a) published in another language other than English, (b) not indexed in any of the common research databases, and (c) unpublished due to their design as small, pilot or feasibility studies. Potentially, with availability of resources, including such studies in an updated systematic review in the future may be worthwhile.

Still, the systematic review presented in this thesis contributes a first review of its kind. It has helped to inform the status of psychological treatments in East and Southeast Asia, and to an extent also points to a continuing need for conducting culturally sensitive research in this part of the world.

There are limited data available to guide the development of psychological treatments for chronic pain in Singapore. Following the rationale (discussed in Chapter 5) that treatment designs are more effective when they are designed to be culturally sensitive, firstly obtaining the views of both patients and health professionals, stakeholders in chronic pain treatment (discussed respectively in Chapters 7 and 8) was essential.

Overall, patients and health professionals appeared to share similar views regarding barriers to psychological treatment for chronic pain, specifically patients' expectations of cure, patients not able to see the relevance of psychological treatment for chronic pain, and high treatment costs. Discrepancies expressed in patients' treatment experiences and health professionals' treatment practices, contributed further barriers to treatment. For example, patients reported that they accepted treatment when health professionals communicated appropriate content and could explain the benefits of psychological treatment. Patients want their doctors to consider other avenues beyond treating pain as a physical condition, and they want prompt referrals for the right treatment. However, it seems that such needs are not currently met in treatment.

Health professionals were perceived as not knowing much about psychotherapy and what psychologists do. These professionals themselves did not want to be perceived as not believing that patients' pain is legitimate or believing that it might be a wholly psychological problem. They sometimes assumed that patients were not ready for psychological treatment and hence did not refer patients for treatment. Unwittingly, health professionals may, through this process of self-imposed treatment assumptions, deprive and deter patients from taking up psychological treatment. The experiences of patients in

treatment may be enhanced if health professionals are well versed with issues surrounding psychological treatment for chronic pain, if they educate patients on the benefits and clarify misconceptions that patients may have about this treatment.

Patients and health professionals agreed on several factors that could improve the provision and uptake of psychological treatment for pain in Singapore. These include a close therapeutic relationship with an empathetic health professional, financial support from the Singapore government, information about the benefits of treatment, stories of successful treatment, and the use of technology, media and advertising.

People with pain “want solutions, care, understanding and clarity related to psychological treatments” (Yang et al., 2015, p. 6) and health professionals face challenges in meeting these needs. Scepticism and ambivalence towards receiving psychological treatment and referring patients for psychological treatment are barriers and challenges to overcome before the uptake rates of psychological treatment will improve. Whether these expectations and experiences would appear in other healthcare settings in Southeast Asia remains unclear. Separate studies conducted within these settings in other countries within Southeast Asia are needed to determine this.

People with chronic pain and residing in countries with differing cultural, national and healthcare contexts are likely to have different treatment needs. For psychological treatment to be effective, treatment barriers, needs, practical methods of treatment delivery and psychological models suited to the treatment population have to be considered in treatment design. An understanding of these factors is essential so that the treatment developed is not only sensitive to the wider cultural needs of the treatment population but also ensures that

treatment is applicable, accessible and will likely be used (Yang et al., 2016c). The development of psychological treatment is in its infancy in Southeast Asia, including Singapore. At least, results presented in Chapters 7 and 8 already provide some important insights from the viewpoints of stakeholders regarding potential barriers and facilitators for psychological treatments for chronic pain in Singapore. To strengthen these findings, a quantitative cross-sectional survey study (described in Chapter 9) was subsequently conducted to examine psychological treatment needs and relevance of PF, as applied to a wider sample of people with chronic pain from Singapore (N = 200).

Preliminary analysis showed that pain duration was the only differentiating factor between those that utilised treatment services at the pain management clinic (PMC) and those that utilised treatment services elsewhere. This is interesting, as one would expect that increased pain and a general reduction in function would be main reasons for seeking specialty services. The model of healthcare delivery, primary, tertiary, re-structured and private healthcare practices, and referral processes adopted within the Singapore healthcare system, may partially explain this. Such a trend may be unique to Singapore and not observed elsewhere.

Overall, people want proof that psychological treatment works for chronic pain, with non-users reporting a stronger need for proof of treatment success as a facilitator for treatment uptake. Compared to PMC-users, both non-PMC users and non-users felt that access to psychological treatment could be improved. Treatment costs currently associated with psychological treatment for chronic pain in Singapore remain a strong deterrent to treatment uptake.

Participants mostly preferred face-to-face treatment followed by online treatment. Those who were open to a combination of methods preferred a

combination of psychologically-based face-to-face and online treatment. In general, participants believed that psychological treatment designed to span a period of 4-5 weeks, scheduled at one 45-minute session/ week with a service fee of approximately S\$ 37.46 would be likely accepted by people with chronic pain. Although preliminary, knowledge of these broad treatment preferences and needs of people with chronic pain who are current and potential users of pain treatment services in Singapore may contribute to the development of more appropriate and effective treatments.

This is the first study of chronic pain in Singapore where the opinions of people currently utilising specialty treatment services, or other treatment services, and those not utilising any form of treatment services were sought to inform potential treatment development. These treatment preferences were considered and appropriately applied, such as when designing a psychologically-based intervention for people with chronic pain, as described in Chapter 10.

To some degree, study findings broadly support the role of PF in explaining daily and emotional functioning in people with chronic pain in Singapore and preliminarily support the utility of the PF model as relevant within this population. Mostly small to moderate correlations were shown between PF and physical and emotional functioning, with a small relationship also shown between PF and pain intensity. The relationship between PF and pain intensity demonstrated here was not surprising, as the main focus of PF is not on pain reduction but on improved daily functioning, achieved through increased openness, awareness, and engagement (Hayes et al., 2011; McCracken & Morley, 2014).

PF was also shown to make a unique contribution to physical and emotional functioning beyond pain intensity. The acceptance component of PF appeared most relevant while the data on committed action did not provide a case for its unique and significant role. Further investigation including (a) a more complete set of measures of PF, perhaps in a sample of people with greater treatment need and, (b) exploring potential cultural or language differences that may have influenced survey responses is a next recommended step. Perhaps, other differences inherent in the current sample population including healthcare systems and practices may also explain the performance of PF here. These assumptions would need to be explored further.

Collectively, each of the studies discussed in Chapters 6 to 9 provide potentially helpful insights into the current status, barriers and needs of psychological treatment for chronic pain in Singapore. Findings obtained from each study builds on the previous, and contribute important knowledge that eventually informed and contributed to the design and development of the culturally adapted ACT-based, iACT-CEL program for chronic pain in this population.

Chapter 10 discussed the development of the iACT-CEL program, a combination of a face-to-face and internet-based, culturally adapted ACT-based intervention for chronic pain in Singapore. In recent years, psychological treatment models that have predominantly been developed and applied in populations in Europe and North America have begun to be adapted to tailor to the needs of diverse communities (Griner & Smith, 2006). Such adapted treatments that are designed to be culturally sensitive, consider the needs of the target population and have produced some encouraging preliminary results (Griner & Smith, 2006).

In the development of iACT-CEL, knowledge of Singaporean culture was applied in treatment delivery and incorporated key psychological treatment needs shared by a group of patients and people in the Singapore community with chronic pain. The main modifications applied in iACT-CEL focused on a modification of language, included culture-specific examples and a therapist-patient match on characteristics, with the therapist who is Singaporean, delivering treatment. The development of iACT-CEL also broadly contributes to the current trend in e-delivery systems for chronic pain treatment in North America and Europe.

A test of the iACT-CEL program, as described in Chapter 11, demonstrated successful recruitment and low drop-out rates. There was reasonably high treatment acceptability and satisfaction, meeting the treatment expectations of people using it. Although not the main focus of treatment, results demonstrating significant small effects on depression and pain intensity at 3-months follow-up, point to the potential transferability of ACT-based treatments to Singapore. Conversely, there were limited improvements found for pain interference, satisfaction with life and all measures of PF.

Results demonstrating clinically meaningful improvement in at least one outcome for 75.8% of participants are encouraging. Nearly half the participant sample (45.5%) reported most improvements in pain and depression. A proportion of participants reported a decline in outcomes following treatment. Participants who reported a decline mainly reported a decline in satisfaction with life (24.2%). Any worsening of health or functioning during a treatment for chronic pain is important to understand. Plausible reasons for this decline are already discussed in Chapter 11.

Contrary to expectations, processes of PF and treatment outcomes of pain interference and satisfaction with life did not demonstrate significant patterns of change following the iACT-CEL intervention as theory would predict. As the study was only a feasibility trial with a small sample, further development of the iACT-CEL protocol focused on enhancing treatment dose or intensity, as well as a bigger trial is necessary to examine efficacy and effectiveness of this type of treatment for chronic pain in Singapore. At least preliminarily, results presented here point to the potential utility of further developing an ACT-based treatment for people with chronic pain in Singapore.

There is much potential to develop, implement and encourage uptake of psychological treatments in Singapore, especially if they are priced affordably (Yang et al., 2015, 2016b, 2016c). Beyond treatment costs, (a) providing patients with more information about the utility of psychological treatment for chronic pain, (b) showing evidence of treatment success, (c) using technology to enhance treatment delivery while maintaining a therapeutic relationship with patients, (d) designing treatment based on PF and ACT and, (d) including optimal adaptations of ACT-based metaphors and experiential exercises are likely to contribute to successful treatment outcome. Incorporating these considerations may also contribute to higher treatment acceptability, satisfaction and adherence.

Collectively, the studies presented in this thesis improve understanding of the influence of culture and healthcare practices on the perception and experience of psychological treatment for chronic pain in Singapore. At the same time, despite the differences in culture, healthcare environment and the healthcare funding structure in Singapore from those present in Western societies, many similar treatment experiences and treatment needs are

demonstrated here. It would appear that, generally speaking, recommendations to treat chronic pain from a psychological perspective (Jensen & Turk, 2014) are equally applicable for people with chronic pain in Singapore.

12.2 Cultural Sensitivity of ACT Measures

The ACT model has been described as a “unified model of behaviour change” (Hayes et al., 2012). An examination of how ACT processes can be measured, applied and be effective for people across diverse cultures and backgrounds is essential to improve the universal applicability of PF and ACT. More well designed studies and adapted measures of ACT, tested in a wide variety of cultural groups are still needed to support the universal assertion of the model.

At present, of the ACT measures, the AAQ-II in particular appears unifactorial, reliable and is well validated. It is probably the single most widely used measure of PF in ACT research. As mentioned in Chapter 5, different versions of the AAQ-II have been adapted for use in both clinical and non-clinical populations (see Bond et al., 2011), and validated in different language variants as it applies to different culture groups. Adapted versions of the AAQ-II so far in Dutch (Fledderus et al., 2012; Jacobs et al., 2008), French (Monestes et al., 2009), German (Gloster et al., 2011), Portuguese (Pinto-Gouveia et al., 2012), Italian (Pennato et al., 2013), Spanish (Ruiz et al., 2013) and in Chinese (Zhang et al., 2014) all support a single 7-item factor structure with good internal consistency across all studies ($\alpha = 0.75 - 0.97$).

Results from studies with the adapted AAQ-II demonstrate an association between general psychological acceptance and outcome variables such as depression, anxiety and stress (Fledderus et al., 2012; Gloster et al., 2011, Pennato et al., 2013; Ruiz et al., 2013), quality of life (Ruiz et al., 2013),

mental well-being (Fledderus et al., 2012; Pennato et al., 2013) and mindfulness (Pennato et al., 2013). Results from the Dutch study (Fledderus et al., 2012) also support the incremental validity of the AAQ-II in explaining variance in anxiety, depression, and positive mental health beyond mindfulness. The consistency in results found across different language variants of the AAQ-II supports the AAQ-II as a stable, valid, and reliable measure of PF across cultures. From these data, perhaps limited as they are, PF and ACT appear to successfully cross national, linguistic, and cultural boundaries.

Although none of the ACT measures have yet to be validated in a Singapore population, results from a cross-sectional study demonstrate an association between the AAQ-II, CPAQ-8 and CAQ with pain interference, depression and impact of depression in a chronic pain population in Singapore (Yang et al., 2016c, discussed in Chapter 9). Once again, to a limited degree this shows some relevance and applicability of PF for people with chronic pain in Singapore. A further examination of the cultural validity of PF and cultural sensitivity of ACT measures as tested in Singapore and the wider Southeast Asian population is needed to strengthen findings.

Overall, the studies presented in this thesis point to PF as having some relevance to the chronic pain population in Singapore and support the feasibility of developing a psychologically-based treatment for this population based on the ACT treatment model. In general, results encourage further development from this model of behaviour change. ACT's underlying processes have been shown to be applicable across cultures, to the degree that this has been directly tested. ACT appears likely to be effective regardless of language, race or ethnicity, and the studies in this thesis add to the growing evidence base. The important caveat here however is that the evidence base is very small.

12.3 Clinical Implications

There is much that can be done to improve the uptake of psychological treatments for chronic pain in Singapore. Health promotion efforts undertaken by the Health Promotion Board (HPB) in Singapore, and initiatives by other stakeholders in educating both the public and health professionals on the benefits of psychological treatment for chronic pain will be important and useful first steps. In a healthcare system that supports a top-down, hierarchical approach, endorsement of psychological treatment for chronic pain by healthcare policy makers may change the way that treatment for chronic pain is taught in medical schools and to allied health professions. Other needed resources include a specially trained workforce that can provide competent and high fidelity treatment, as well as financial support so that people can find it affordable.

Educating health professionals, especially doctors and nurses who are first line treatment providers, on doctor-patient communication from the early stages of their training is important. This aspect of training seems likely to help health professionals to cultivate better therapeutic relationships with patients and to improve patients' treatment experiences.

Treatments designed to improve PF for people with chronic pain in Singapore may help patients achieve more effective management of chronic pain and move away from living under the influence of their pain to living according to their goals and values. The iACT-CEL program appears feasible and may later appear effective. Its design may particularly suit the situation in Singapore, including a shortage of psychologists professionally trained in chronic pain management, and it may also address potential stigma, poor accessibility and potentially unaffordable treatment costs for psychological

treatment of chronic pain. Many of the clinical implications discussed however in part require changes in health care systems, policy, and essentially in culture. These changes are likely to take time. At the same time change can be initiated from within services and at the point of initial consultation. An approach that involves health professionals putting their assumptions about patients' treatment preferences of psychological treatment aside, taking the initiative to understand the benefits of psychological treatment and securing their position to confidently refer patients for such treatments. More treatment effectiveness studies initiated by stakeholders hoping to improve the uptake of psychological treatment are equally important. Results from these studies can then be applied to initiate changes at a wider national level.

12.4 Limitations

The main limitation of this thesis is that much of the data have been contributed by patients seeking treatment from one multidisciplinary pain clinic in one tertiary hospital in Singapore. There are only two interdisciplinary pain clinics in Singapore. As both tertiary hospitals are governed by similar policies, procedures, and healthcare practices, patients' treatment expectations and experiences may be similar at both centres. The utility of the PF model and outcomes testing the feasibility of iACT-CEL however may yield slightly different results. Further studies will be needed to confirm this.

Many of the measures, in particular the PF measures used in the empirical studies described in Chapters 9 and 11 have not been validated in the current population. It is possible that (a) choice of words or concepts, (b) the way items were phrased (c) meanings attached to items that were not salient to the participant samples and (d) level of English language skills required on these measures could have affected participants' responses.

As much as broad recommendations in methodology and interpretation of data for conducting culturally-sensitive research were followed, no study is a final and definitive statement on this topic. Methods can improve and reliability needs to be demonstrated. It is likely that greater customising and adaptation of iACT-CEL could be done (discussed in Chapters 10 and 11). The studies presented here formed part of a PhD thesis and that means there were restricted resources, and that restricts what can be done. It is certainly not “gold” standard but a set of next steps than can be improved.

12.5 Future Steps

Steps to improve the uptake of psychological treatment, expand the evidence base of psychological treatments for chronic pain in Singapore, and improve treatment efficacy, require a broader base of support and effort. This effort appears to require health professionals who are firstly interested in managing people with chronic pain, trained in the biopsychosocial treatment model of pain, are committed to helping people with pain live a full life, and have confidence to recommend patients for psychological treatment. It will also specifically require psychologists professionally trained in managing chronic pain and health professionals willing to conduct research in this area.

Cultural adaptations of ACT treatment have to be tailored to the target population, designed to support treatment engagement, and above all, need to focus on improving treatment outcomes, and reducing premature treatment failure (Hwang, 2011; La Roche & Lustig, 2013). Hwang (2011, p. 239) suggested five phases to follow when adapting treatments: “(a) generating knowledge and collaborating with stakeholders (b) integrating generated information with theory and empirical and clinical knowledge (c) reviewing the initial culturally adapted intervention and (e) finalising the culturally adapted

intervention.” These steps should be considered when designing culturally sensitive ACT-based treatment studies in the future.

It would be valuable to replicate the empirical studies conducted in this thesis in other countries and healthcare settings in Southeast Asia. The data presented in this thesis contributes to understanding the healthcare practices and issues surrounding psychological treatment for chronic pain in only one out of eleven countries in Southeast Asia. As yet, a majority of these countries do not appear to have any studies on psychological treatments for chronic pain. Comparative data are necessary. Availability of such data will not only contribute to our understanding of similarities and differences in potential barriers, challenges and needs faced by people with chronic pain in these countries compared to Singapore, it will also help determine the applicability of psychological treatments for chronic pain in these settings, and provide a much needed evidence base for Southeast Asia.

12.6 Conclusion

There is hope that published results from this thesis will contribute at least a small step toward change in the way patients and health professionals perceive psychological treatment, contribute to referral patterns favouring psychological treatments and set the pace for the conduct of more empirical studies in this area. The empirical studies presented in this thesis are unique to the context of Singapore and first of its kind in Southeast Asia for chronic pain, and now more studies like these should follow.

REFERENCES

- Abdul Jalil N., Sulaiman, Z., Awang, M.S., Omar, M. (2009). Retrospective review of outcomes of a multimodal chronic pain service in major teaching hospital: A preliminary experience in Universiti Sains Malaysia. *Malays J Med Sci*, 16(4): 55-65.
- Adams, N., Ravey, J., Taylor, D. (1996). Psychological models of chronic pain and implications for practice. *Physiother*, 82(2), 124-129.
- Airaksinen, O., Brox, J.I., Cedraschi, C. et al. (2006). Chapter 4: European guidelines for the management of chronic nonspecific low back pain. *Eur Spine J*, 15(Suppl 2), s192– s300.
- Akerblom, S., Perrin, S., Fischer, M.R., McCracken, L.M. (2016). A validation and generality study of the Committed Action Questionnaire in a Swedish sample with chronic pain. *Int J Behav Med*, 23(3), 260-270.
- Alonso, M.A., Lopez, A., Losada, A., & Gonzalez, J.L. (2013). Acceptance and commitment therapy and selective optimization with compensation for older people with chronic pain: A pilot study. *Behav Psychol/Psicologia Conductual*, 21(1), 59-79.
- Andersson, G., Bergström, J., Buhrman, M., Carlbring, P., Holländare, F., Viktor Kaldoc, V.,...Waaracet, J. (2008). Development of a new approach to guided self-help via the Internet. The Swedish experience. *J Techno Hum Serv*, 26, 161-181.
- American Psychological Association. (2003). Guidelines on multicultural education, training, research, practice, and organizational change for psychologists. *Am Psychol*, 58, 377- 402.

- American Psychological Association Presidential Taskforce on Evidence-Based Practice in Psychology (2006). Evidence-based practice in psychology. *Am Psychol*, 61, 271-285.
- American Psychological Association (2014). Retrieved from <http://www.apa.org/monitor/2014/06/datapoint.aspx>. (Accessed 23rd Nov 2015).
- Andersson, S.A., & Rydenhag, B. (1985). Cortical nociceptive systems. *Philos Trans R Soc Lond B Biol Sci*, 308, 347-359.
- Arch, J.J., Eifert, G.H., Davies, C., Vilardaga, J.P., Rose, R.D., Craske, M.G. (2012). Randomized clinical trial of cognitive behavioral therapy (CBT) versus acceptance and commitment therapy for mixed anxiety disorders. *J Consul Clin Psychol*, 80(5), 750-765.
- Arch, J.J., & Mitchell, J.L. (2015). An Acceptance and Commitment Therapy (ACT) group intervention for cancer survivors experiencing anxiety at re-entry. *Psycho-Oncology*, 25(5), 610-615
- Arch, J.J., Wolitzky-Taylor, K.B., Eifert, G.H., Craske, M.G. (2012). Longitudinal treatment mediation of traditional cognitive behavioral therapy and acceptance and commitment therapy for anxiety disorders. *Behav Res Ther*, 50, 469-478.
- Arnett, J.J. (2008). The neglected 95%: Why American psychology needs to be less American. *Am Psychol*, 63, 602-614.
- Astin, J.A., Berman, B.M., Bausell, B., Lee, W., Hochberg, M. (2003). The efficacy of mindfulness meditation plus qigong movement therapy in the treatment of fibromyalgia: A randomized controlled trial. *J Rheumatol*, 30, 2257-2262.
- Attal, N., Cruccu, G., Baron, R., Haanpää, M., Hansson, P., Jensen, T.S.,...European Federation of Neurological Societies (2010). EFNS

- guidelines on the pharmacological treatment of neuropathic pain: 2010 revision. *Eur J Neurol*, 17, 1113-23.
- Attal, N., Cruccu, G., Haanpaa, M., Hansson P, Jensen, T.S., Nurmikko, T...EFNS Taskforce (2006). EFNS guidelines on pharmacological treatment of neuropathic pain. *Eur J Neurol*, 13, 1153-1169.
- Bach, P., & Hayes, S.C. (2002). The use of Acceptance and Commitment Therapy to prevent the rehospitalization of psychotic patients: A randomized controlled trial. *J Consult Clin Psychol*, 70(5), 1129-1139.
- Baer, R. A. (2003). Mindfulness training as a clinical intervention: a conceptual and empirical review. *Clin Psychol Sci Pract*, 10(2), 125-143.
- Baer, R.A. (2005). *Mindfulness based treatment approaches: Clinician's guide to evidence base and applications*. New York: Academic Press.
- Baer, R.A., & Krietemeyer, J. (2006). Overview of mindfulness and acceptance based treatment approaches. In R. Baer (Ed.), *Mindfulness Based Treatment Approaches; Clinician's guide to Evidence base and Applications* (pp. 3-27) Burlington MA: Elsevier Academic Press.
- Baer, R.A., Smith, G.T., Hopkins, J., Krietemeyer, J., Toney, L. (2006). Using self-report assessment methods to explore facets of mindfulness. *Assessment*, 13(1), 27-45.
- Bailey, K.M., Carleton, R.N., Vlaeyen, J.W.S., Asmundson, G.J. (2010). Treatments addressing pain-related fear and anxiety in patients with chronic musculoskeletal pain: a preliminary review. *Cogn Behav Ther*, 39, 46-63.
- Baliki, M.N., Chialvo, D.R., Geha, P.Y, Levy, R.M., Harden, R.N., Parrish, T.B., Apkarian, A.V. (2006). Chronic pain and the emotional brain, specific brain activity associated with spontaneous fluctuations of intensity of chronic back pain. *J Neurosci*. 26(47), 12165-12173.

- Barolat, G. (2000). Spinal cord stimulation for chronic pain management. *Arch Med Res*, 31(3), 258-262.
- Bates, M.S., Rankin-Hill, L., Sanchez-Ayendez, M. (1997). The effects of the cultural context of health care on treatment of and response to chronic pain and illness. *Soc Sci Med*, 45(9), 1433-1447.
- Bee, P.E., Lovell, K, Lidbetter, N., Easton K, Gask L.(2010). "You can't get anything perfect" : User perspectives on the delivery of cognitive behavioural therapy by telephone. *Soc Sci Med*, 71(7), 1308-1315.
- Belsey, J. (2002). Primary care workload in the management of chronic pain: a retrospective cohort study using a GP database to identify resource implications for UK primary care. *J Med Econ*, 5, 39-52.
- Bendayan, R., Esteve, R., Blanca, M.J. (2012). New empirical evidence of the validity of the Chronic Pain Acceptance Questionnaire: The differential influence of activity engagement and pain willingness on adjustment to chronic pain. *Bri J Health Psychol*, 17, 314-326.
- Bender, J.L., Radhakrishnan, A., Diorio, C., Englesakis, M., Jadad, A.R. (2011). Can pain be managed through the internet? A systematic review of randomised controlled trials. *Pain*, 152, 1740-1750.
- Benish, S.G., Quintana, S., Wampold, B.E. (2011). Culturally adapted psychotherapy and the legitimacy of myth: A direct-comparison meta-analysis. *J Counsel Psychol*, 58, 279-289.
- Benjamin, L.T., & Wallers, K. (1984). Henry Rutgers Marshall--the forgotten American Psychological Association president. *Rev Hist Psicol*, 5(1-2), 63-67.
- Bennet, R., & Nelson, D. (2006). Cognitive-behavioral therapy for fibromyalgia. *Nat Clin Pract Rheumatol*, 2, 416-424.

- Benoist, M., Boulu, P., Hayem, G. (2012). Epidural steroid injections in the management of low-back pain with radiculopathy: an update of their efficacy and safety. *Eur Spine J*, 21(2), 204-213
- Benyamin, R.M., Manchikanti, L., Parr, A.T., Diwan, S., Singh, V., Falco, F.J.,... Hirsch J.A. (2012). The effectiveness of lumbar interlaminar epidural injections in managing chronic low back and lower extremity pain. *Pain Phys*, 15(4), E363-404.
- Bernal, G., Bonilla, J., Bellido, C. (1995). Ecological validity and cultural sensitivity for outcome research: Issues for the cultural adaptation and development of psychosocial treatments with Hispanics. *J Abnorm Child Psychol*, 23(1), 67-82.
- Betancourt, J.R., Green, A.R., Carrillo, J.E., Park, E.R. (2005). Cultural competence and health care disparities: key perspectives and trends. *Health Aff (Millwood)*, 24(2), 499-505.
- Bishop, G.D. (1998). East meets West: Illness cognition and behaviour in Singapore. *Appl Psychol*, 47, 519-534.
- Bishop, F.L., Yardley, L., Lewith, G.T. (2008). Treatment appraisals and beliefs predict adherence to complementary therapies: A prospective study using a dynamic extended self-regulation model. *Brit J of Health Psychol*, 13, 701-718.
- Blackledge, J.T. (2003). An introduction to Relational Frame Theory: Basics and Applications. *Behav Anal Today*, 3(4), 421-433.
- Block, J.A. & Wulfert, E. (2000). Acceptance or change: Treating socially anxious college students with ACT or CBGT. *A Context for Science with a Commitment to Behavior Change*, 1, 1-55.

- Blyth, F.M., March, L.M., Brnabic, A.J., Jorm, L.R., Williamson, M., Cousins, M.J. (2001). Chronic pain in Australia: a prevalence study. *Pain*, 89, 127-134.
- Bohlmeijer, Fleddeurs, N., Rokx, T.A., Pieterse, M.E. (2011). Efficacy of an early intervention based on Acceptance and Commitment Therapy for adults with depressive symptomatology: Evaluation in a randomized controlled trial. *Behav Res Ther*, 49(1), 62-67.
- Bohlmeijer, E., & Hulsbergen, M. (2013). *A beginner's guide to mindfulness: Live in the moment*. New York: Open University Press.
- Bohlmeijer, E., Prenger, R., Tall, E., & Cuijpers, P. (2010). The effects of mindfulness-based stress reduction therapy on mental health of adults with a chronic medical disease: A meta-analysis. *J Psychosom Res*, 68, 539-544.
- Bond, F.W., & Bunce, D. (2000). Mediators of change in emotion-focused and problem-focused worksite stress management interventions. *J Occup Health Psychol*, 5(1), 156-163.
- Bond, F.W., & Bunce, D. (2003). The role of acceptance and job control in mental health, job satisfaction, and work performance. *J Appl Psychol*, 88, 1057-1067.
- Bond, F.W., Flaxman, P.E., van Veldhoven, M.J.P.M., Biron, M. (2010). The impact of psychological flexibility and acceptance and commitment therapy (ACT) on health and productivity at work. In J. Houdmont & S. Leka (Eds.). *Contemporary occupational health psychology: Global perspectives on research, education, and practice* (pp. 296-313). Chichester, UK: Wiley-Blackwell.
- Bond, F.W., Hayes, S.C., Baer, R.A., Carpenter, K.M., Guenole, N., Orcutt, H.K.,...Zettle, R.D. (2011). Preliminary psychometric properties of the

- Acceptance and Action Questionnaire-II: A revised measure of psychological flexibility and experiential avoidance. *Behav Ther*, 42, 676-88.
- Bonica, J.J. (1953). *The management of pain with special emphasis on the use of analgesic block in diagnosis, prognosis, and therapy*. Philadelphia, Pa: Lea & Febiger.
- Borkovec, T.D., & Nau, S.D.(1972). Credibility of analogue therapy rationales. *J Behav Ther & Exp, Psychiat*, 3, 257-260.
- Borsook, D., Upadhyay, J., Chudler, E.H., Becerra, L. (2010). A key role of the basal ganglia in pain and analgesia—insights gained through human functional imaging. *Mol Pain*, 6, 27.
- Boulanger, A., Clark, A.J., Squire, P. Cui, E., Horbay, G.L. (2007). Chronic pain in Canada: have we improved our management of chronic non cancer pain? *Pain Res Manage*, 12, 39-47.
- Bradbury, K.J., Bishop, F.L., Yardley, Y., Lewith, G. (2013). Patients' appraisals of public and private healthcare: A qualitative study of physiotherapy and osteopathy. *J Health Psychol*, 18(10), 1307-1318.
- Branstetter-Rost, A., Cushing, C., Douleh, T. (2009). Personal values and pain tolerance: does a values intervention add to acceptance? *J Pain*, 10, 887-892.
- Braun, V., & Clarke, V. (2006). Using thematic analysis in psychology. *Qual Res Psychol*, 3, 77-101.
- Breen, A., Austin, H., Champion-Smith, C., Carr, E., Mann, E. (2007). "You feel so hopeless": A qualitative study of GP management of acute back pain. *Eur J Pain*, 11(1), 21-29.

- Breivik, J., Collett, B., Ventafridda V., Cohen, R., Gallacher, D. (2006). Survey of chronic pain in Europe: prevalence, impact on daily life, and treatment. *Eur J Pain*, 10, 287-333.
- Bremander, A., Bergman, S., Arvidsson, B. (2009). Perception of multimodal cognitive treatment for people with chronic widespread pain-Changing one's life plan. *Disabil Rehabil*, 31(24), 1996-2004.
- Briggs, A.M., Jordan, J.E., Buchbinder, R., Burnett, A.F., O'Sullivan, P.B., Chua, J.Y.,...Straker LM. (2010). Health literacy and beliefs among a community cohort with and without chronic low back pain. *Pain*, 150(2), 275-283.
- British Psychological Society (BPS). Retrieved from <http://www.bps.org.uk/psychology-public/origins-timeline/origins-timeline>. (Accessed 14th October 2015).
- Brooks, J., & Tracey, I. (2005). From nociception to pain perception: imaging the spinal and supraspinal pathways. *J Anat*, 207, 19-33.
- Brown, L.A., Forman, E.M., Herbert, J.D., Hoffman, K.L., Yuen, E.K., Goetter, E.M. (2011). A randomized controlled trial of acceptance-based behavior therapy and cognitive therapy for test anxiety: A pilot study. *Behav Modif*, 35, 31-53.
- Browne, R.H. (1995). On the use of a pilot sample for sample size determination. *Stat. Med*, 14, 1933-1940.
- Bucks, R.S., Hawkins, K., Skinner, T.C., Horn, S., Seddon, P., Horne, R. (2009). Adherence to treatment in adolescents with cystic fibrosis: The role of illness perceptions and treatment beliefs. *J Pediatr Psychol*, 34(8), 893-902.
- Buhrman, M., Faltenhag, S., Strom, L., Andersson G. (2004). Controlled trial of Internet-based treatment with telephone support for chronic back pain. *Pain*, 111, 368-377.

- Buhrman, M., Skoglund, A., Husell, J., Bergstrom, T.G., Hursti, T., Bendelin, N., ...Andersson, G. (2013). Guided internet-delivered acceptance and commitment therapy for chronic pain patients: A randomized controlled trial. *Behav Res Ther*, *51*, 307-315.
- Bydon, M., De la Garza-Ramos, R., Macki, M., Baker, A., Gokaslan, A.K., Bydon, A. (2014). Lumbar fusion versus nonoperative management for treatment of discogenic low back pain: a systematic review and meta-analysis of randomized controlled trials. *J Spinal Disord Tech*, *27*, 297–304.
- Cairns, D., & Pasino, J. (1977). Comparison of verbal reinforcement and feedback in the operant treatment of disability due to chronic low back pain. *Behav Ther*, *8*, 621-630.
- Cairns, D., Thomas, L., Mooney, V., Pace, J.B. (1976). A comprehensive treatment approach to chronic low back pain. *Pain*, *2*, 301-308.
- Cameron, T. (2004). Safety and efficacy of spinal cord stimulation for the treatment of chronic pain: a 20-year literature review. *J Neurosurg (Spine 3)*, *100*, 254-267.
- Cardosa, M.S., Gurpreet, R., Tee, H.G.T. (2008). *Chronic Pain: The third National Health and Morbiity Survey 2006, vol 1*. Kuala Lumpur: Institute of Public Health, Ministry of Health Malaysia, 262.
- Cardosa, M., Osman, Z.L., Nicholas, M., Tonkin, L., Williams, A., Abd Aziz, K.,... Mohd Dahari, N. (2012). Self-management of chronic pain in Malaysian patients: effectiveness trial with 1-year follow-up. *TMB*, *2*, 30-37.
- Carmody, J., & Baer, R.A. (2008). Relationships between mindfulness practice and levels of mindfulness, medical and psychological symptoms and well-being in a mindfulness-based stress reduction program. *J Behav Med*, *31(1)*, 23-33.

- Carpenter, K.M., Stoner, S.A., Mundt, J.M., Stoelb, B. (2012). An online self-help CBT intervention for chronic lower back pain. *Clin J Pain*, 28, 14-22.
- Casey, K.L (1982) Neural mechanisms of pain: an overview. *Acta Anaesthesiol Scand*, 74, 13–20.
- Cederberg, J.T., Cernvall, M., Dahl, J., von Essen, L., Ljungman, G. (2016). Acceptance as a mediator for change in acceptance and commitment therapy for persons with chronic pain? *Int J Behav Med*, 23(1), 21-29.
- Chan, W.L.S., Hui, E., Chan, C., Cheung, D., Wong, S., Wong, R.,...Woo J. (2011). Evaluation of chronic disease self-management programme (CDSMP) for older adults in Hong Kong. *JNHA*, 15(3), 209-214.
- Chaparro, L.E., Furlan, A.D., Deshpande, A., Mailis-Gagnon, A., Atlas, S., Turk, D.C. (2013). Opioids compared to placebo or other treatments for chronic low-back pain. *Cochrane Database Syst Rev*, 8: CD004959. doi: 10.1002/14651858.CD004959.pub4
- Cherkin, D., Deyo, R., Wheeler, K., Cioi, M.A. (1995). Physicians' views about treating low back pain, the results of a national survey. *Spine*, 20, 1-10.
- Cheung, M.N., Wong, T.C.M., Yap, J.C.M., Chen, P.P. (2008). Validation of the Chronic Pain Acceptance Questionnaire (CPAQ) in Cantonese-speaking Chinese patients. *J Pain*, 9(9), 823-832.
- Chiesa, A., & Malinowski (2011). Mindfulness-Based approaches: Are they all the same? *J Clin Psych*, 67(4), 404-424.
- Chiesa, A., & Serretti, A. (2010). A systematic review of neurobiological and clinical features of mindfulness meditations. *Psychol Med*, 40, 1239-1251.
- Cho, S., Heiby, E.M., McCracken, L.M., Moon, D-E, Lee, J-H. (2012). Psychometric properties of a Korean version of the Chronic Pain Acceptance Questionnaire in chronic pain patients. *Qual Life Res*, 21(6), 1059-1064.

- Cho, S., McCracken, L.M., Heiby, E.M., Moon, D-E., Lee, J-H. (2013). Pain acceptance-based coping in complex regional pain syndrome Type 1: daily relation with pain intensity, activity, and mood. *J Behav Med*, 36, 531-538.
- Chong, S.A., Abdin, E., Vaingankar, J.A., Heng, D., Sherbourne, C., Yap, M., ...Subramaniam, M. (2012). A population-based survey of mental disorders in Singapore. *Ann Acad Med Singapore*, 41(2),49-66.
- Chou, R., Loeser, J.D., Owens, D.K. (2009a).Interventional therapies, surgery, and interdisciplinary rehabilitation for low back pain: an evidence-based clinical practice guideline from the American Pain Society. *Spine (Phila Pa 1976)*, 34(10), 1066-1077.
- Chou, R., Loeser, J.D., Owens, D.K., Rosenquist, R.W., Atlas, S.J., Baisden, J., ...American Pain Society Low Back Pain Guideline Panel (2009b). Interventional therapies, surgery, and interdisciplinary rehabilitation for low back pain: An evidence-based clinical practice guideline from the American Pain Society. *Spine*, 34(10), 1066-1077.
- Chou, R., Turner, J.A., Devine, E.B., Hansen, R.N., Sullivan, S.D., Blazina, I.,... Deyo, R.A. (2015). The effectiveness and risks of long-term opioid therapy for chronic pain: a systematic review for a National Institutes of Health Pathways to Prevention Workshop. *Ann Intern Med*, 162(4), 276-286.
- Clark, J.A., Brown, C.A., Jones, A., El-Deredy, W. (2008). Dissociating nociceptive modulation by the duration of pain anticipation from unpredictability in the timing of pain. *Clin Neurophysiol*, 119, 2870-2878.
- Cleeland, C.S., & Ryan, K.M. (1994). Pain assessment: global use of the Brief Pain Inventory (Review). *Ann. Acad. Med. Singapore*, 23,129-138.
- Cochrane Library. Retrieved from <http://onlinelibrary.wiley.com/cochranelibrary/search>. (Assessed 16th October 2015).

- Cohen J. (1988). *Statistical power analysis for the behavioural sciences* (2nd ed.). New York: Academic Press.
- Cole, M. (2006). Internationalism in psychology: We need it now more than ever. *Am Psychol*, 61, 904-917.
- Consumer Barometer. Retrieved from <http://www.consumerbarometer.com>. (Accessed 19th August 2015).
- Cook, A.J., Brawer, P.A., Vowles, K.E. (2006). The fear-avoidance model of chronic pain: validation and age analysis using structural equation modeling. *Pain*, 121,195–206.
- Cooper, K., Smith, B.H., Hancock, E. (2009). Patients' perceptions of self-management of chronic low back pain: evidence of enhancing patient education and support. *Physiother*, 95, 43-50.
- Corbett, M., Foster, N., Ong, B.N. (2009). GP attitudes and self-reported behaviour in primary care consultations for low back pain. *Fam Pract*, 26(5), 359-364.
- Cramer, H., Haller, H., Lauche, R., Dobos G. (2012). Mindfulness-based stress reduction for low back pain. A systematic review. *BMC Complem Altern Med*, 12, 162-169.
- Crombez, G., Eccleston, C., Van Damme, S., Vlaeyen, J.W., Karoly, P. (2012). Fear-avoidance model of chronic pain: the next generation. *Clin J Pain*, 28(6), 475-483.
- Crombez G, Vlaeyen, J.W.S., Heuts, P.H.T.G., Lysens, R. (1999). Pain related fear is more disabling than pain itself: Evidence on the role of pain-related fear in chronic back pain disability. *Pain*, 80, 329-339.

- Cuijpers, P., van Straten, A., Andersson, G. (2008). Internet administered cognitive behavior therapy for health problems: a systematic review. *J Behav Med*, 31, 169-177.
- Currow, D.C., Agar, M., Plummer, J.L., Blyth, F.M., Abernethy, A. (2010). Chronic pain in South Australia-population levels that interfere extremely with activities of daily living. *Aust N Z J Public Health*, 34, 232-239.
- Cutler, R.B., Fishbain, D.A., Rosomoff, H.L., Abdel-Moty E, Khalil, T.M., Rosomoff, R.S. (1994). Does nonsurgical pain center treatment of chronic pain return patients to work? A review and meta-analysis of the literature. *Spine (Phila Pa 1976)*, 19(6), 643-652.
- Dahl, J., Wilson, K.G., & Nilsson, A. (2004). Acceptance and commitment therapy and the treatment of persons at risk for long-term disability resulting from stress and pain symptoms: a preliminary randomized trial. *Behav Ther*, 35, 785-802.
- Daykin, A.R., & Richardson, B. (2004). Physiotherapists' pain beliefs and their influence on the management of patients with chronic low back pain. *Spine*, 29, 783-795.
- De Haes H., & Bensing, J. (2009). Endpoints in medical communication research, proposing a framework of functions and outcomes. *Patient Educ Couns*, 74, 287-294.
- De Jong, J.R., Vlaeyen, J.W.S., Onghena, P., Cuyppers, C., den Hollander, M., Ruijgrok, J. (2005). Reduction of pain-related fear in complex regional pain syndrome type 1: the application of graded exposure *in vivo*. *Pain*, 116, 264-275.
- Dear, B.F., Titov, N., Perry, K.N., Johnston, L., Wootton, B.M., Terides MD.,...Hudson, J.L. (2013). The Pain Course: A randomized controlled trial

- of a clinician-guided Internet-delivered cognitive behavior therapy program for managing chronic pain and emotional well-being. *Pain*, 154, 942-950.
- Department of Statistics, Singapore. Retrieved from <http://www.singstat.gov.sg/statistics>. (Accessed 16th October 2015).
- Derbyshire, S.W.G. (2000). Exploring the pain "neuromatrix". *Curr Rev Pain*, 4, 467-477.
- Derry, S., Moore, R.A., Rabbie, R. (2012). Topical NSAIDs for chronic musculoskeletal pain in adults. *Cochrane Database of Systematic Reviews*, Issue 9: CD007400. doi: 10.1002/14651858.CD007400.pub2.
- Dickson, G.L., & Kim, J.I. (2003). Reconstructing a meaning of pain: Older Korean American women's experiences with the pain of osteoarthritis. *Qual Heal Res*, 13(5), 675-688.
- Diener, E., Emmons, R.A., Larsen, R.J., Griffin, S. (1985). The Satisfaction with Life Scale. *J Pers Assess*, 49, 71-75.
- Dima, A., Lewith, G.T., Little, P., Moss-Morris, R., Foster, N.E., Bishop, F.L. (2013). Identifying patients' beliefs about treatments for chronic low back pain: A focus & group study. *Br J Gen Pract*, 63(612), 490-498.
- Division 12, A.P.A. (2010). Psychological Treatments (Niwot, CO.:American Psychological Association). <http://www.div12.org/PsychologicalTreatments/treatments.html>
- Domenech, J., Sanchez-Zuriaga, D., Segura-Orti, E., Espejo-Tort, B., Lison, J.F. (2011). Impact of biomedical and biopsychosocial training sessions on the attitudes, beliefs, and recommendations of health care providers about low back pain: A randomized clinical trial. *Pain*, 152, 2557-2563.
- Drayer, R.A., Henderson, J., Reidenber, M. (1999). Barriers to better pain control in hospitalized patients. *J Pain Symptom Manage*, 17, 434-440.

- Dubben, H-H & Bornholdt, H-P-B. (2005). Systematic review of publication bias in studies on publication bias. *BMJ*, 331(7514), 433-434.
- Dworkin, R.H., Turk, D.C., Farrar, J.T., Haythornthwaite, J.A., Jensen, M.P., Katz, N.P.,...Witter J. (2005). Core outcome measures for chronic pain clinical trials: IMMPACT recommendations. *Pain*, 113, 9-19.
- Dworkin, R.H., Turk, D.C., Wyrwich, K.W., Beaton, D., Cleeland, C.S., Farrar, J.T.,...Zavisic S. (2008). Interpreting the clinical importance of treatment outcomes in chronic pain clinical trials: IMMPACT recommendations. *J Pain*, 9(2), 105-121.
- Dworkin, S.F., Von Korff, M., Whitney, C.W., LeResche, L., Dicker, B.G., Barlow, W. (1990). Measurement of characteristic pain intensity in field research. *Pain, Suppl 5*, S290.
- Eccleston, C., Fisher, E., Craig, L. Duggan, G.B., Rosser, B.A., Keogh, E. (2014). Psychological therapies (internet-delivered) for the management of chronic pain in adults (Review). *Cochrane Database of Systematic Reviews, issue 2*: CD010152. doi: 10.1002/14651858.
- Eccleston, C., Morley, S., Williams, A., Yorke, L., Mastroiannopoulou, K. (2002). Systematic review of randomised controlled trials of psychological therapy for chronic pain in children and adolescents, with a subset meta-analysis of pain relief. *Pain*, 99(1-2), 157-165.
- Eccleston, C., Williams, A.C., Morley, S. (2009). Psychological therapies for the management of chronic pain (excluding headaches) in adults. *Cochrane Database Sys Rev, Issue 2*.
- Effective Public Health Practice Project Quality Assessment Tool for Quantitative Studies. <http://www.ephpp.ca/tools.html>. (Accessed May 2014).

- Ehde, .M., Dilworth, T.M., Turner, J.A. (2014). Cognitive-behavioral therapy for individuals with chronic pain: efficacy, innovations, and directions for research. *Am Psychol*, 69(2), 153-166.
- Eide, H., Lere, L., Sorebo, O. (2016). The Norwegian versions of the Chronic Pain Acceptance Questionnaire CPAQ-20 and CPAQ-8-validation and reliability studies. *Disabil Rehabil*, 3, 1-8.
- Ekeland, A.G., Bowes, A., Flottorp, S. (2010). Effectiveness of telemedicine: a systematic review of reviews. *Int J Med Inform*, 79, 736-771.
- Elsegood, K.J., & Wongpakaran, N. (2011). The effects of guided imagery on affect, cognition and pain in older adults in residential care. *Res Gerontol Nurs*, 5(2), 114-122.
- Elzahaf, R.A., Tashani, O.A., Unsworth, B.A., Johnson, M.I. (2012). The prevalence of chronic pain with an analysis of countries with a Human Development Index less than 0.9: a systematic review without meta-analysis. *Curr. Med. Res. Opin.* 28(7), 1221–1229.
- Engel, G. (1959). Psychogenic pain and the pain prone patient. *Am J Med*, 26, 899-918.
- Espeland, A., & Baerheim, A. (2003). Factors affecting general practitioners' decisions about plain radiology for back pain: implications for classification of guideline barriers-a qualitative study. *BMC Health Ser Res*, 3(1), 8.
- Ferreira, P.H., Ferreira, M.L., Latimer, J., Maher, C.G., Refshauge, K., Sakamoto, A., Garofalo, R. (2004). Attitudes and beliefs of Brazilian and Australian physiotherapy students towards chronic back pain: a cross-cultural comparison. *Physiother Res Int*, 9, 13-23.

- Feros, D.L., Lane, L., Ciarrochi, J., Blackledge, J.T. (2013). Acceptance and Commitment Therapy (ACT) for improving the lives of cancer patients: a preliminary study. *Psycho-oncology*, 22(2), 459-464.
- Finnerup, N.B., Otto, M., McQuay, H.J., Jensen, T.S., Sindrup, S.H. (2005). Algorithm for neuropathic pain treatment: An evidence-based proposal. *Pain*, 118, 289-305.
- Finnerup, N.B., Sindrup, S.H., Jensen, T.S. (2010). The evidence for pharmacological treatment of neuropathy pain. *Pain*, 150, 573-581.
- Fish, R.A., McGuire, B., Hogan, M., Morrison, T.G., Stewart, I. (2010). Validation of the Chronic Pain Acceptance Questionnaire (CPAQ) in an Internet sample and development and preliminary validation of the CPAQ-8. *Pain*, 149, 435-443.
- Fishbain, D., Cutler, R.B., Rosomoff, H.L., Rosomoff, R.S. (2000). What is the quality of the implemented meta-analytic procedures in chronic pain treatment meta-analyses? *Clin J Pain*, 16, 73-85.
- Flaxman, P.E., & Bond, F.W. (2010). A randomised worksite comparison of acceptance and commitment therapy and stress inoculation training. *Behav Res Ther*, 43, 816-820.
- Flor, H., Birbaumer, N., Schulte, W., Roos R. (1991). Stress related electromyographic responses in patients with chronic temporomandibular pain. *Pain*, 46, 145-152.
- Flor, H., Fydrich, T., Turk, D.C. (1992). Efficacy of multidisciplinary pain treatment centers: a meta-analytic review. *Pain*, 49, 221-230.
- Flor, H., & Turk, D.C. (2011). *Chronic pain: An integrated biobehavioral approach*. Seattle, WA: IASP Press.

- Fordyce, W.E. (1973). An operant conditioning method for managing chronic pain. *Postgrad Med*, 53, 123-128.
- Fordyce, W.E. (1976). *Behavioral methods for chronic pain and illness*. St. Louis: Mosby.
- Fordyce, W.E., McMahon, R., Rainwater, G., Jackins, S., Questad, K., Murphy, T., De Lateur, B. (1981). Pain complaint-exercise performance relationship in chronic pain. *Pain*, 10, 311-321.
- Fordyce, W.E., Roberts, A.H., Sternbach, R.A. (1985). The behavioural management of chronic pain: a response to critics. *Pain*, 22, 113-125.
- Forman, E.M., Herbert, J.D., Moitra, E., Yeomans, P.D., Geller, P.A. (2007). A randomized controlled effectiveness trial of acceptance and commitment therapy and cognitive therapy for anxiety and depression. *Behav Modif*, 31(6), 772-799.
- Forman, E.M., Shaw, J.A., Goetter, E.M., Herbert, J.D., Park, J.A., Yuen, E.K. (2012). Long-term follow-up of a randomized controlled trial comparing acceptance and commitment therapy and standard cognitive behavior therapy for anxiety and depression. *Behav Ther*, 43(4), 801-811.
- Franco, A., Malhotra, N., Simonovits, G. (2014). Publication bias in the social sciences: Unlocking the file drawer. *Sci*, 345 (6203), 1502-1505.
- Frohlich, C., Jacobi, F., Wittchen, H.U. (2006). DSM-IV pain disorder in the general population. An exploration of the structure and threshold of medically unexplained pain symptoms. *Eur Arch Psychiatry Clin Neurosci.*, 256, 187-196.
- Fuchs, C., Lee, J.K., Roemer, L., Orsillo, S.M. (2013). Using mindfulness-and acceptance-based treatments with clients from nondominant cultural and/or

- marginalized backgrounds clinical considerations, meta-analysis findings, and introduction to the special series. *Cogn Behav Pract*, 20, 1-12.
- Fullen, B.M., Baxter, G.D., O'Donovan, B.G.G., Doody, C., Daly, L., Hurley, D.A. (2008). Doctors' attitudes and beliefs regarding acute low back pain management: A systematic review. *Pain*, 136, 388-396.
- Fullen, B.M., Doody, C., Baxter, G.D., Daly, L.E., Hurley, D.A. (2008). Chronic low back pain: non-clinical factors impacting on management by Irish doctors. *Ir J Med Sci*, 177(3), 257-263.
- Gardner-Nix, J., Backman, S., Barbati, J., Grummitt J. (2008). Evaluating distance education of a mindfulness-based meditation programme for chronic pain management. *J Telemed Telecare*, 14, 88-92.
- Gaskin, D.J., & Richard, P. (2012). The economic costs of pain in the United States. *J Pain*, 13(8), 715-724.
- Gatchel, R.J., & Bruga, D. (2005). Multidisciplinary intervention for injured workers with chronic low back pain. *SpineLine*, 6(5), 8-13.
- Gatchel, R.J., McGeary, D.D., McGeary, C.A., Lippe, B. (2014). Interdisciplinary chronic pain management: past, present and future. *Am Psychol*, 69(2), 119-130.
- Gatchel, R.J. & Okifuji, A. (2006). Evidence-based scientific data documenting the treatment and cost-effectiveness of comprehensive pain programs for chronic pain management. *J Pain*, 7, 779-793.
- Gatchel, R.J., Peng, Y.B., Peters, M.L., Fuchs, D.N., Turk, D.C. (2007). The biopsychosocial approach to chronic pain: scientific advances and future directions. *Psychol Bull*, 133, 581-624.

- Gaudiano, B.A. (2009). Ost's (2008) methodological comparison of clinical trials of Acceptance and Commitment Therapy versus Cognitive Behavior Therapy: matching apples with oranges? *Behav Res Ther*, *47*, 1066-1070.
- Gaudiano, B.A. (2011). A review of acceptance and commitment therapy (ACT) and recommendations for continued scientific advancement. *Sci Rev Mental Health Pract*, *8*, 5-22.
- Gaudiano, B.A., & Herbert, J.D. (2006). Acute treatment of inpatients with psychotic symptoms using Acceptance and Commitment Therapy: Pilot results. *Behav Res Ther*, *44*(3), 415-437.
- George, S.Z., Valencia, C., Zeppieri, G., Robinson, M.E. (2009). Development of a self-report measure of fearful activities for patients with low back pain: the Fear of Daily Activities Questionnaire. *Phys Ther*, *89*, 969-979.
- Gheldof, E.L., Crombez, G., Van den Bussche, E., Vinck, J., Van Nieuwenhuysse, A., Moens, G.,...Vlaeyen, J.W. (2010). Pain-related fear predicts disability, but not pain severity: a path analytic approach of the fear-avoidance model. *Eur J Pain*, *14*, 870, e871–870.
- Gifford, E.V., Kohlenberg, B.S., Hayes, S.C., Antonuccio, D.O., Piasecki, M.M., Rasmussen-Hall, M.L., Palm, K.M. (2004). Acceptance-based treatment for smoking cessation. *Behav Ther*, *35*, 689-705.
- Gillanders, D. T., Bolderston, H., Bond, F. W., Dempster, M., Flaxman, P. E., Campbell, L.,...Remington, R. (2014) The development and initial validation of the Cognitive Fusion Questionnaire. *Behav Ther*, *45*, 83-101,
- Glajchen, M. (2001). Chronic pain: treatment barriers and strategies for clinical practice. *J Am Board Fam Pract*, *14*, 211-218.

- Glaser, B.G., & Strauss, A. (1967). The discovery of grounded theory. In B.G. Glaser & A. Strauss (Eds.), *The discovery of grounded theory* (pp. 1-18). London: Weidenfeld and Nicolson.
- Global Information Technology Report 2014. Retrieved from <http://www.weforum.org/gitr>. (Accessed 19th August 2015).
- Glombiewski, J.A., Sawyer, A.T., Gutermann, J., Koenig, K., Rief, W., Hofmann, S.G. (2010). Psychological treatments for fibromyalgia: a meta-analysis. *Pain, 151*, 280-295.
- Gloster, A.T., Klotsche, J., Chaker, S., Hummel, K.V., Hoyer, J. (2011). Assessing psychological flexibility: What does it add above and beyond existing constructs? *Psychol Assess, 23*, 970-982.
- Godin, G., Naccache, H., Morel, S., Ebacher, M.F. (2000). Determinants of nurses' adherence to universal precautions for venipunctures. *Am J Infect Control, 28(5)*, 359-364.
- Goldberg, D.S., & McGee, S.J. (2011). Pain as a global public health priority. *BMC Public Health, 11*, 770.
- Goldenberg, D.L., Burckhardt, C., Crofford, L. (2004). Management of fibromyalgia syndrome. *JAMA, 292*, 2388-2395.
- Goossens, M.E.J.B., Vlaeyen, J.W.S., Hidding, A., Kole-Snijders, A., Kole-Snijders, A., Evers, S.M. (2005). Treatment expectancy affects the outcome of cognitive-behavioral interventions in chronic pain. *Clin J Pain, 21*, 18 - 26.
- Gotnik, R.A., Chu, P., Busschbach, J.J.V., Benson, H., Fricchione, G.L., Hunink, M.G.M. (2015). Standardised Mindfulness-based intervention in healthcare: An overview of systematic reviews and meta-analyses of RCTs. *PLoS One, 10(4)*:e0124344.

- Gregg, J.A., Callaghan, G.M., Hayes, S.C. Glenn-Lawson, J.L. (2007). Improving diabetes self-management through acceptance, mindfulness, and values: A randomized controlled trial. *J Consul Clin Psychol*, 75(2), 336-343.
- Gutierrez, O., Luciano, C., Rodriguez, M., Fink, B.C. (2004). Comparison between an acceptance-based and a cognitive-control based protocol for coping with pain. *Behav Ther*, 35, 767-783.
- Griffiths, F., Lindenmeyer, A., Powell, J., Lowe, P., Thorogood, M. (2006). Why are healthcare interventions delivered over the internet? A systematic review of the published literature. *J Med Internet Res*, 8, e10.
- Griner, D., & Smith, T.B. (2006). Culturally adapted mental health intervention: A meta-analytic review. *Psychother Theor Res Pract Train*, 43, 531-548.
- Hadjistavropoulos, T., Craig, K.D., Duck, S., Cano A, Goubert L, Jackson PL,.... Fitzgerald, T.D. (2011). A biopsychosocial formulation of pain communication. *Psychol Bull*, 137(6), 910-939.
- Haldorsen, E.M.H., Brage, S., Johannesen, T.S., Tellnes, G., Ursin, H. (1996). Musculoskeletal pain: concepts of disease, illness and sickness certification in health professionals in Norway. *Scan J Rheumatol*, 25, 224-232.
- Hall, G.C.N. (2005). Introduction to the special section on multicultural and community psychology: clinical psychology in context. *J Consult Clin Psychol*, 73(5), 787-789.
- Hall, G.C.N., Hong, J.J., Zane, N.W.S., Meyer, O.L. (2011). Culturally competent treatments for Asian Americans: The relevance of mindfulness and acceptance-based psychotherapies. *Clin Psychol Sci Pract*, 18, 215-231.
- Hann, K.E.J., & McCracken, L.M. (2014). A systematic review of randomized controlled trials of Acceptance and Commitment Therapy for adults with

- chronic pain: Outcome domains, design quality and efficacy. *J Context Behav Sci*, 3, 217-227.
- Harris, R. (2009). *ACT made simple: An Easy-To-Read Primer on Acceptance and Commitment Therapy*. Oakland, CA: New Harbinger Publications.
- Harris, R., & Aisbett, B. (2013). *The happiness trap pocketbook: An illustrated guide on how to stop struggling and start living*. Auckland, NZ: Exisle Publishing.
- Hayes, S.C. (1987). A contextual approach to therapeutic change. In N. Jacobson (Ed.). *Psychotherapists in clinical practice: Cognitive and behavioral perspectives* (pp. 327-387). New York: Guilford Press.
- Hayes, S.C. (1996). Developing a theory of derived stimulus relations. *J Exp Anal Beh*, 65, 309-311.
- Hayes, S.C. (2005). *Get out of your mind and into your life*. Oakland, CA: New Harbinger Publications.
- Hayes, S.C., Barnes-Holmes, D., Roche, B. (2001). *Relational frame theory: A post-Skinnerian account of human language and cognition*. New York: Plenum Press.
- Hayes, S.C., Bisset, R., Roget, N., Padilla, M., Kohlenberg, B.S., Fisher, G.,...Niccolls, R. (2004). The impact of acceptance and commitment training and multicultural training on the stigmatizing attitudes and professional burnout of substance abuse counselors. *Behav Ther*, 35, 821-835.
- Hayes, S., & Duckworth, M.P. (2006). Acceptance and Commitment Therapy and traditional Cognitive Behavior Therapy approaches to pain. *Cogn Behav Pract*, 13, 185-187.

- Hayes, S.C., Hayes, L.J., Reese, H.W. (1988). Finding the philosophical core. A review of Stephen C. Pepper's World Hypotheses. *J Exp Anal Behav*, 50, 97-111.
- Hayes, S.C., Hayes, L.J., Reese, H.W., Sarbin, T.R. (1993). (Eds.) *Varieties of scientific contextualism*. Reno, NV: Context Press.
- Hayes, S.C., Levin, M.E., Plumb-Villardaga, J., Villatte, J.L., Pistorello, J. (2013). Acceptance and commitment therapy and contextual behavioral science: examining the progress of a distinctive model of behavioral and cognitive therapy. *Behav Ther*, 44(2), 180-198.
- Hayes, S., Luoma, J., Bond, F., Masuda, A., Lillis, J. (2006). Acceptance and commitment therapy: model processes and outcomes. *Behav Res Ther*, 44, 1-25.
- Hayes, S.C., Muto, T., Masuda, A. (2011). Seeking cultural competence from the ground up. *Clin Psychol Sci Pract*, 18, 232-237.
- Hayes, S.C., Pistorello, J., Levin, M. (2012). Acceptance and Commitment Therapy as a unified model of behavior change. *Couns Psychol*, 40, 976-1002.
- Hayes, S.C., Strosahl, K.D., & Wilson, K.G. (1999). *Acceptance and Commitment Therapy: An experiential approach to behavior change*. New York: The Guilford Press.
- Hayes, S.C., Strosahl, K.D., Wilson, K.G. (2012). *Acceptance and commitment therapy: The process and practice of mindful change (2nd edition)*. New York, NY: The Guilford Press.
- Hayes, S.C., Strosahl, K.D., Wilson, K.G., Bissett, R.T., Pistorello, J., Toarmino D.,...McCurry, S.M. (2004). Measuring experiential avoidance: A preliminary test of a working model. *Psychol Rec*, 54, 553-578.

- Hayes, S.C., & Toarmino, D. (1995). If behavioral principles are generally applicable, why is it necessary to understand cultural diversity? *Behav Therapist, 18*, 21-23.
- Hayes, S.C., Villatte, M., Levin, M., Hildebrandt, M. (2011). Open, aware and active: Contextual approaches as an emerging trend in the behavioural and cognitive therapies. *Annu. Rev. Clin. Psychol, 7*, 141-168.
- Hays, P. (2009). Integrating evidence-based practice, cognitive-behavior therapy and multicultural therapy: Ten steps for culturally competent practice. *Prof Psychol- Res Pr 40*, 354-360.
- Health and Care Professions Council. Retrieved from <http://www.hcpcuk.co.uk/aboutregistration/professions/index.asp?id=14>. (Accessed 23rd November 2015).
- Heath, D.L., & Reid-Finlay, M.A. (1998). Conceptual framework for nursing management of pain. *Contemp Nurse, 7*(2), 68-71.
- Hedman, E., Ljótsson, B., Lindefors, N. (2012). Cognitive behaviour therapy via the Internet: a systematic review of applications, clinical efficacy and cost-effectiveness. *Expert Rev Pharmacoecon Outcomes Res, 12*(6), 745-764.
- Heine, S.J., Lehman, D.R., Markus, H.R., Kitayama, S. (1999). Is there a universal need for positive self-regard? *Psychol Rev, 106*, 766-794.
- Henrich, J., Heine, S.J., Norenzayan, A. (2010). The weirdest people in the world? *Behav Brain Sci, 33*, 61-83.
- Henschke, N., Ostelo, R.W., van Tulder, M.W., Vlaeyen JW, Morley S, Assendelft WJ, Main, C.J. (2010). Behavioural treatment for chronic low back pain. *Cochrane Database Syst Rev, 7*: CD002014. doi: 10.1002/14651858.CD002014.pub3.

- Hertzog, M.A. (2008). Considerations in determining sample size for pilot studies. *Res Nurs Health, 31*, 180-191.
- Higgins, J.P.T., Altman, D.G., Gøtzsche, P.C., Jüni, P., Moher, D., Oxman, A.D.,...Sterne, J.A.C. (2011). The Cochrane Collaboration's tool for assessing risk of bias in randomized trials. *BMJ*, <http://dx.doi.org/doi:10.1136/bmj.d5928>
- Higgins, J.P.T., & Green, S. (2011). *Cochrane handbook for systematic reviews of interventions*. Retrieved from <http://handbook.cochrane.org/>. (Accessed 23rd November 2015)
- Ho, K.Y., Chua, N.H., George, J.M., Yeo SN, Main NB, Choo CY.,...Pain Association of Singapore Task Force (2013). Evidence-based guidelines on the use of opioids in chronic non-cancer pain-A consensus statement by the Pain Association of Singapore Task Force. *Ann Acad Med Singapore, 42*, 138-152.
- Ho, KY., & Siau, C. (2009). Chronic pain management: Therapy, drugs and needles. *Ann Acad Med Singapore, 38(11)*, 929-930.
- Hoffman, S.G., & Asmundson, G.J. (2008). Acceptance and mindfulness-based therapy: New wave or old hat? *Clin Psych Rev, 28*, 1-16.
- Hoffman, B.M., Papas, R.K., Chatkoff, D.K., Kerns, R.D. (2007). Meta-analysis of psychological interventions for chronic low back pain. *Health Psychol, 26*, 1-9.
- Hofstede, G.H. (1984). *Culture's consequences: International differences in work-related values*. Beverly Hills: Sage Publications.
- Hollander, M., de Jong, J.R., Volders, S., Goossens, M.E., Smeets, R.J., Vlaeyen, J.W. (2010). Fear reduction in patients with chronic pain: a learning theory perspective. *Exp Rev Neurother, 10*, 1733-1745.

- Horrell, S. (2008). Effectiveness of cognitive-behavioral therapy with adult ethnic minority clients: A review. *Prof Psychol Res Pr*, 39, 160-168.
- Houben, R.M.A., Vlaeyen, J.W.S., Peters, M. (2004). Health care providers' attitudes and beliefs towards common low back pain: factor structure and psychometric properties of the HC-PAIRS. *Clin J Pain*, 20, 37-44.
- Howarth, M., Warne, T., Haigh, C. (2014). Pain from the inside: understanding the theoretical underpinning of person-centered care delivered by pain teams. *Pain Manag Nurs*, 15(1), 340-348.
- Howell SL. (1994). A theoretical model for caring with women with chronic non-malignant pain. *Qual Health Res*, 4, 94-122.
- Hwang, W-C. (2011). Cultural adaptations: A complex interplay between clinical and cultural issues. *Clin Psychol Sci Pract*, 18, 238-241.
- Iannetti, G.D., & Mouraux, A. (2010). From the neuromatrix to the pain matrix (and back). *Exp Brain Res*, 205, 1-12.
- IASP Taxonomy. <http://www.iasppain.org/Education/Content.aspx?ItemNumber=1698&navItemNumber=576#Pain>. (Accessed 1st March 2015).
- Ibrahim, T., Tleyjeh, I.M., Gabbar, O. (2008). Surgical versus non-surgical treatment of chronic low back pain: a meta-analysis of randomised trials. *Int Orthop*, 32(1), 107–113.
- Infocomm Development Authority of Singapore (IDA). Retrieved from <http://www.ida.gov.sg/Tech-Scene-News/Facts-and-Figures> (Accessed 21st August 2015).
- Ingvar, M. (1999). Pain and functional imaging. *Philos Trans R Soc Lond B Biol Sci*, 354, 1347-1358.

- Institute of Medicine (2011). *Relieving pain in America: A blueprint for transforming prevention, care, education and research*. Washington, DC. National Academies Press.
- Jackson, J.E. (1992). *After a while no one believes you: real and unreal pain*. In: M-J.D. Good, P.E. Brodwin, B.J. Good, A. Kleinman (Eds.), *Pain as human experience* (pp. 138-168). Berkeley, CA: University of California Press.
- Jacobs, N., Kleen, M., De Groot, F., A-Tjak, J. (2008). Measuring experiential avoidance: The Dutch version of the Acceptance and Action Questionnaire-II (AAQ-II). *Gedragstherapie*, 45, 389-399.
- Jensen, M.P. (2011). Psychosocial approaches to pain management: An organizational framework. *Pain*, 152, 717-725.
- Jensen, M.P., & Turk, D.C. (2014). Contributions of psychology to the understanding and treatment of people with chronic pain: Why it matters to all psychologists. *Am Psychol*, 69(2), 105-118.
- Johannes, C.B., Le, T.K., Zhou, X., Johnston, J.A., Dworkin, R.H. (2010). The prevalence of chronic pain in United States adults: results of an Internet-based survey. *J Pain*, 11, 1230-1239.
- Johnston, M., Foster, M., Shennan, J., Starkey, N.J., Johnson, A. (2010). The effectiveness of an Acceptance and Commitment Therapy self-help intervention for chronic pain. *Clin J Pain*, 26, 393-402.
- Jones A.P.K., Brown, W.D., Friston, K.J, Qi L.Y., Frackowiak, R.S. (1991). Cortical and subcortical localization of response to pain in man using positron emission tomography. *Proc R Soc Lond*, 244, 39–44.
- Kabat-Zinn, J. (1990). *Full catastrophe living: Using the wisdom of your body and mind to face stress, pain, and illness*. New York, NY: Dell.

- Kabat-Zinn, J. (1994). *Wherever you go, there you are: Mindfulness meditation in everyday life*. New York: Hyperion.
- Kamper, S.J., Apeldoorn, A.T., Chiarotto, A., Smeets, R.J., Ostelo, R.W., Guzman, J.,...van Tulder, M.W. (2015). Multidisciplinary biopsychosocial rehabilitation for chronic low back pain: Cochrane systematic review and meta-analysis. *BMJ*, 350, h444.
- Karjalainen, K., Malmivaara, A., van Tulder, M., Roine, R., Jauhiainen, M., Hurri, H., Koes, B. (2000). Multidisciplinary rehabilitation for fibromyalgia and musculoskeletal pain in working age adults. *Cochrane Database Syst Rev* (2), CD001984.
- Kawi J. (2014). Chronic low back pain patients' perceptions on self-management, self- management support, and functional ability. *Pain Manag Nurs* , 15(1), 258-264.
- Keefe, F.J., Blumenthal, J., Baucom, D., Affleck G, Waugh R, Caldwell DS,...Lefebvre, J. (2004). Effects of spouse assisted coping skills training and exercise training in patients with osteoarthritic knee pain: A randomized controlled study. *Pain*, 110(3), 539-549.
- Keefe, F.J., Dunsmore, J., Burnett, R. (1992). Behavioural and cognitive-behavioural approaches to chronic pain: recent advances and future directions. *J Consult Clin Psychol*, 60, 528-536.
- Keefe, F.J., & Gil, K.M. (1986). Behavioral concepts in the analysis of chronic pain syndromes. *J Consult Clin Psychol*, 54(6), 776–783.
- Keefe, F.J., Jacobs, M., Edwards, C. (1997). Persistent pain: Cognitive-behavioral approaches to assessment and treatment. *Semin Anesth*, 16(2), 117-126.

- Keller, S., Bann, C.M., Dodd, S.L., Schein, J., Mendoza, T.R., Cleeland, C.S. (2004). Validity of the brief pain inventory for use in documenting the outcomes of patients with non-cancer pain. *Clin J Pain, 20(5)*, 309-318.
- Kemani, M.K., Hesser, H., Olsson, G.L., Lekander, M., Wicksell, R.K. (2016). Processes of change in Acceptance and Commitment Therapy and Applied Relaxation for long-standing pain. *Eur J Pain, 20(4)*, 521-531.
- Kemani, M.K., Olsson, G.L., Lekander, M., Hesser, H., Andersson E., Wicksell, R. (2015). Efficacy and cost-effectiveness of ACT and Applied Relaxation for long-standing pain. *Clin J Pain, 31(11)*, 1004-1016.
- Kemler, M.A., & Furne, C.A. (2002) Economic evaluation of spinal cord stimulation for chronic reflex sympathetic dystrophy. *Neurology, 59*, 1203–1209.
- Keng, S.L., Smoski, M.J., & Robins, C.J. (2011). Effects of mindfulness on psychological health: A review of empirical studies. *Clin Psychol Rev, 31*, 1041-1056.
- Keogh, E., Rosser, B.A., Eccleston, C. (2010). e-Health and chronic pain management: Current status and development. *Pain, 151*, 18-21.
- Kerry, S.M., & Bland, J.M. (1998). The intraclass correlation coefficient in cluster randomization. *BMJ, 316*, 1455.
- Kim, D.M., Wampold, B.E., Bolt, D.M. (2006). Therapist effects in psychotherapy: random effects modeling of the National Institute of Mental Health Treatment of Depression Collaborative Research Program data. *Psychother Res, 16*, 161-172.
- Kishita, N., & Shimada, H. (2011). Effects of acceptance-based coping on task performance and subjective stress. *J Behav Ther Exp Psy, 42*, 6-12.

- Kitahara, M., Kojima, K.K., Ohmura, A. (2006). Efficacy of interdisciplinary treatment for chronic non-malignant pain patients in Japan. *Clin J. Pain*, 22(7), 647-655.
- Koes, B.W., van Tulder, M.W., Ostelo, R., Kim Burton, A., Waddell, G. (2001). Clinical guidelines for the management of back pain in primary care: an international comparison. *Spine*, 26(22), 2504-2514.
- Koes, B.W., van Tulder, M.W., Thomas, S. (2006). Diagnosis and treatment of low back pain. *BMJ*, 332, 1430-1434.
- Kozasa, E.H., Tanaka, L.H., Monson, C., Little, S., Leao, F.C., Peres, M.P. (2012). The effects of meditation-based interventions on the treatment of fibromyalgia. *Curr Pain Headache Rep*, 16, 383-387.
- Kroenke, K., Spitzer, R.L., Williams, J.B. (2001). The PHQ-9: Validity of a brief depression severity measure. *J Gen Intern Med*, 16, 606-613.
- Krolkowski, A.M. (2013). The Effectiveness of Internet-Based Mindfulness Interventions for Physical and Mental Illnesses: A Narrative Review. *Int J Cyber Behav, Psychol Learn*, 3(4), 84-96.
- Kuijpers, T., van Middelkoop, M., Rubinstein, S.M., Ostelo, R., Verhagen, A., Koes, B.W., van Tulder, M.W. (2011). A systematic review on the effectiveness of pharmacological interventions for chronic non-specific low-back pain. *Eur Spine J*, 20(1), 40-50.
- Kumar, K., & Rizvi, S. (2013). Cost effectiveness of spinal cord stimulation therapy in management of chronic pain. *Pain Med*, 14, 1631–1649.
- Kunde, V., & Treede, R.D. (1993). Topography of middle latency somatosensory evoked potential following painful laser stimuli and non-painful electrical stimuli. *Electroencephalogr Clin Neurophysiol*, 88, 280-289.

- La Roche, M. (2012). *Cultural Psychotherapy: Theory, Methods and Practice*. Thousand Oaks, CA: Sage.
- La Roche, M., & Lustig, K. (2013). Being mindful about the assessment of culture: A cultural analysis of culturally adapted acceptance-based behavior therapy approaches. *Cogn Behav Pract*, 20, 60-63.
- Laerum, E., Indahl, A., Sture Skouen, J. (2006). What is “the good back-consultation”? A combined qualitative and quantitative study of the chronic low back patients’ interaction with and perceptions of consultations with specialists. *J Rehabil Med*, 38, 255-262.
- Laloo, C., Jibb, L.A., Rivera, J., Agarwal, A., Stinson, J.N. (2015). “There’s a Pain App for That” : Review of patient-targeted smartphone applications for pain management. *Clin J Pain*, 31(6), 557-563.
- Lamb, S.E., Lall, R., Hansen, Z., Castelnuovo E, Withers EJ, Nichols V.,...The BeST Trial Group. (2010). A multi-center randomised controlled trial of a primary care based cognitive behavioural program for low back pain (the Back Skills Training Trial). *Health Technol Assess*, 14, 1-253.
- Lamb, S.E., Mistry, D., Lall, R., Hansen Z, Evans D, Withers EJ, ...Back Skills Training Trial Group. (2012). Group cognitive behavioural interventions for low back pain in primary care: Extended follow-up of the Back Skills Training Trial. *Pain*, 153, 494-501.
- Lang, S., Kroll, A., Lipinski, S.J., Wessa M, Ridder S, Christmann C.,...Flor, H. (2009). Context conditioning and extinction in humans: differential contribution of the hippocampus, amygdala and prefrontal cortex. *Eur J Neurosci*, 29, 823–832.
- Langley, P.C., Muller-Schwefe, G., Nicolaou, A., Liedgens, H., Pergolizzi, J., Varrassi, G. (2010). The impact of pain on labor force participation,

- absenteeism and presenteeism in the European Union. *J Med Econ*, 13(4), 662-672.
- Lappalainen, P., Granlund, A., Siltanen, S., Ahonen, S., Vitikainen, M., Tolvanen, A., Lappalainen, R. (2014). ACT internet-based vs face-to-face? A randomized controlled trial of two ways to deliver Acceptance and Commitment Therapy for depressive symptoms: An 18-month follow-up. *Behav Res Ther*, 61, 43-54.
- Lau, O.W.Y., Leung, L.N.Y., Wong, L.O.L. (2002). Cognitive Behavioural techniques for changing the coping skills of patients with chronic pain. *HKJOT*, 12, 13-20.
- Lauch, R., Cramer, H., Dobos, G., Langhorst, J., Schmidt, S. (2013). A systematic review and meta-analysis of mindfulness-based stress reduction for the fibromyalgia syndrome. *J Psychosom Res*, 75, 500-510.
- Lavernia, C.J., Alcerro, J.C., Contreras, S.D., Rossi, M.D. (2011). Ethnic and racial factors influencing well-being, perceived pain, and physical function after primary total joint arthroplasty. *Clin Ortho Rel Res*, 469(7), 1838-1845.
- Leeuw, M., Goossens, M.E., Linton, S.J., Crombez, G., Boersma, K., Vlaeyen, J.W. (2007). The fear-avoidance model of musculoskeletal pain: current state of scientific evidence. *J Behav Med*, 30, 77-94.
- Lethem, J., Slade, P.D., Troup, J.D., Bentley G. (1983). Outline of a fear-avoidance model of exaggerate pain perception. *Behav Res Ther*, 21, 401-408.
- Lewis, M., Morley, S., van der Windt, D.A., Hay, E., Jellema, P., Dziedzic, K., Main, C.J. (2010). Measuring practitioner/therapist effects in randomised trials of low back pain and neck pain interventions in primary care settings. *Eur J Pain*, 14, 1033-1039.

- Li, E.J.Q., Li-Tsang, C.W.P., Lam, C.S., Hui, K.Y.L., Chan, C.C.H. (2006). The effect of a "training on work readiness" program for workers with musculoskeletal injuries: A randomized control trial (RCT) study. *J Occup Rehabil*, 16, 529-541.
- Liberman, G., & Naylor, M.R. (2012). Interactive voice response technology for symptom monitoring and as an adjunct to the treatment of chronic pain. *TBM: Pract, Pol Res*, 2(1), 93-101.
- Liddle, S.D., Baxter, G.D., Gracey, J.H. (2007). Chronic low back pain: patients experiences, opinions and expectations for clinical management. *Disabil Rehabil*, 29, 1899-1909.
- Lillis, J., & Hayes, S.C. (2008). Measuring avoidance and inflexibility in weight related problems. *Int J Behav Consul Ther*, 4, 372-378.
- Lillis, J., Hayes, S.C., Bunting, K., Masuda, A. (2009). Teaching acceptance and mindfulness to improve the lives of the obese: A preliminary test of a theoretical model. *Ann Behav Med*, 37, 58-69.
- Linehan, M.M. (1993). *Cognitive behavioral treatment of borderline personality disorder*. New York: Guildford Press.
- Linton, S.J., (1986). Behavioural remediation of chronic pain: a status report, *Pain*, 24, 125-141.
- Linton, S.J., Hellsing, A-L., Larsson, I. (1997). Bridging the gap: Support groups do not enhance long-term outcome in chronic back pain. *Clin J Pain*, 13(3), 221-228.
- Linton, S.J., Melin, L., Gotestam, K.G. (1984). *Behavioral analysis of chronic pain and its management. Progress in behaviour modification. Vol. 18*. New York: Academic Press.

- Linton, S.J., Vlaeyen, J., Ostelo, R. (2002). The back pain beliefs of health care providers: are we fear-avoidant? *J Occup Rehabil*, 12, 223-232.
- Lorig, K.R., Laurent, D.D., Deyo, R.A., Marnell, M.E., Minor, M.A., Ritter, P.L. (2002). Can a back pain e-mail discussion group improve health status and lower health care costs? A randomized study. *Arch Intern Med*, 162, 792-796.
- Lubis, D.U., Jaya, E.S., Arjadi, R., Hanum, L., Astri, K., Putri, M.D.D. (2013). Preliminary study on the effectiveness of short group Cognitive Behavioral Therapy (GCBT) on Indonesian older adults. *PLoS ONE*, 8(2), 1-10.
- Luciano, J.V., Guallar, J.A., Aguado., Lopez-del-Hoyo, Y., Olivan, B., Magallon, R., ...M., Garcia-Campayo, J. (2014). Effectiveness of group acceptance and commitment therapy for fibromyalgia: A 6-month randomized controlled trial (EFFIGACT study). *Pain*, 155, 693-702.
- Lui, F., Duzzi, D., Corradini, M., Serafini M, Baraldi P, Porro CA. (2008). Touch or pain? Spatio-temporal patterns of cortical fMRI activity following brief mechanical stimuli. *Pain*, 138, 362-374.
- Lukoschek, P. (2003). African Americans' beliefs and attitudes regarding hypertension and its treatment: A qualitative study. *J Health Care Poor Underserved*, 14(4), 566-587.
- Lundgren, T., Dahl, J., Hayes, S.C. (2008). Evaluation of mediators of change in the treatment of epilepsy with acceptance and commitment therapy. *J Behav Med*, 31(3), 225-235.
- Lundgren, T., Dahl, J., Yardi, N., Melin, L. (2008). Acceptance and commitment therapy and yoga for drug refractory epilepsy: A randomized controlled trial. *Epilepsy Behav*, 13, 102-108.

- Luoma, J.B., Drake, C., Hayes, S.C., Vilardaga, R. (2014). Substance abuse and psychological flexibility: The development of a new measure. *Addict Res Theory, 19(1)*, 3-13.
- Luoma, J.B., Hayes, S.C., Walser, R.D. (2007). *Learning ACT: An acceptance and commitment therapy skills-training manual for therapists*. Oakland, CA: New Harbinger Publications .
- Lynch, M.E., & Watson, C.P.N. (2006). The pharmacotherapy of chronic pain: A review. *Pain Res Manag, 11(1)*, 11–38.
- Macea, D.D., Gajos, K., Daglia Calil, Y.A., Fregni, F. (2010). The efficacy of Web-based cognitive behavioral interventions for chronic pain: a systematic review and meta-analysis. *J Pain, 11(10)*, 917-929.
- Mailis-Gagnon, A., Furlan, A.D., Sandoval, J.A., Taylor R. (2004). Spinal cord stimulation for chronic pain.. *Cochrane Database Syst Rev, 3:CD003783*.
- Man, A.K.Y., Chu, M.C., Chen, P.P., Ma, M., Gin, T. (2007). Clinical experience with a chronic pain management programme in Hong Kong Chinese patients. *Hong Kong Med J, 13*, 372-378.
- Manca, A., Kumar, K., Taylor, R.S., Jacques, L., Eldabe, S., Meglio, M.,... Sculpher, M.J. (2008). Quality of life, resource consumption and costs of spinal cord stimulation versus conventional medical management in neuropathic pain patients with failed back surgery syndrome (PROCESS trial). *Eur J Pain, 12*, 1047–1058.
- Manchikanti, L., Nampiaparampil, D. E., Manchikanti, K.N., Falco, F.J., Singh, V., Benyamin, R.M.,...Hirsch, J.A. (2015). Comparison of the efficacy of saline, local anaesthetics, and steroids in epidural and facet joint injections for the management of spinal pain: A systematic review of randomized controlled trials. *Surg Neurol Int. 6(Suppl 4)*, S194-235.

- Maniadakis, N., & Gray, A. (2000). The economic burden of back pain in the UK. *Pain, 84*, 95-103.
- Markus, H.R., & Kitayama, S. (1991). Culture and the self: Implications for cognition, emotion and motivation. *Psychol Rev, 98*, 224-253.
- Masedo,, A.I., & Rosa Esteve, M. (2007). Effects of suppression, acceptance and spontaneous coping on pain tolerance, pain intensity and distress. *Behav Res Ther, 45*, 199-209.
- Mason, V.L., Mathias, B., Skevington, S.M. (2008). Accepting low back pain: Is it related to a good quality of life. *Clin J Pain, 24(1)*, 22-29.
- Masuda, A. (2014). Psychotherapy in a cultural context. In A. Masuda (Ed.), *Mindfulness and acceptance in multicultural competency: A contextual approach to social cultural diversity in theory and practice*. Oakland, CA: New Harbinger.
- Matsubara T, Arai YCP, Shimo K, Sato J, Osuga T, Nishihara M, Ushida T. (2010). Effects of Cognitive-Behavioral Therapy on pain intensity and level of physical activity in Japanese patients with chronic pain-a preliminary quasi experimental study. *J Phys Ther, 1*, 49-57.
- Matthias, M.S., Miech, E.J., Myers, L.J., Sargent, C., Bair, M.J. (2012). "There's more to this pain than just pain": How patients' understanding of pain evolved during a randomized controlled trial for chronic pain. *J Pain, 13(6)*, 571-578.
- McBeth, J., Prescott, G., Scotland, G., Lovell, K., Keeley, P., Hannaford, P.,...Macfarlane G.J. (2012). Cognitive behaviour therapy, exercise, or both for treating chronic widespread pain. *Arch Int Med, 172(1)*, 48-57.
- McCracken, L.M. (2005). *Contextual Cognitive-Behavioral Therapy for chronic pain*. Seattle, WA: IASP Press.

- McCracken, L.M. (2013). Committed Action: An application of the psychological flexibility model to activity patterns in chronic pain. *J Pain, 14*(8), 818-835.
- McCracken, L.M., Chilcot, J., Norton, S. (2015). Further development in the assessment of psychological flexibility: A shortened Committed Action Questionnaire (CAQ-8). *Eur J Pain, 19*(5), 677-685.
- McCracken, L.M., & Eccleston, C. (2003). Coping or acceptance: what to do about chronic pain? *Pain, 105*, 197-204.
- McCracken, L.M., & Gutierrez-Martinez, O. (2011). Processes of change in psychological flexibility in an interdisciplinary group –based treatment for chronic pain based on Acceptance and Commitment Therapy. *Behav Res Ther, 49*, 267-274.
- McCracken, L.M., Gutierrez-Martinez, O., Smyth, C. (2013). “Decentering” reflects psychological flexibility in people with chronic pain and correlates with their quality of functioning. *Health Psychol, 32*, 820-823.
- McCracken, L.M., & Jones, R. (2012). Treatment for chronic pain for adults in the seventh and eighth decades of life: A preliminary study of acceptance and commitment therapy (ACT). *Pain Med, 13*, 861-867.
- McCracken, L.M., MacKichan, F., Eccleston, C. (2007). Contextual cognitive-behavioural therapy for severely disabled chronic pain sufferers: Effectiveness and clinically significant change. *Eur J Pain, 11*, 314-322.
- McCracken, L.M., Matthews, A., Tang, T., Cuba, S. (2001). Comparison of Blacks and Whites Seeking Treatment for Chronic Pain. *Clin J Pain, 17*(3), 249-255.
- McCracken, L.M., & Morley, S. (2014). The psychological flexibility model: A basis for integration and progress in psychological approaches to chronic pain management. *J Pain, 15*, 221-234.

- McCracken, L.M., Sato, A., Taylor, G.J. (2013). A trial of a brief group-based form of Acceptance and Commitment Therapy (ACT) for chronic pain in general practice: Pilot outcome and process results. *J Pain, 14*(11), 1398-1406.
- McCracken, L.M., Sato, A., Wainwright, D., House, W., Taylor, G.J. (2014). A feasibility study of brief group-based acceptance and commitment therapy for chronic pain in general practice: recruitment, attendance, and patient views. *Pri Health Care Res Dev, 15*(3), 312-323.
- McCracken, L.M., Spertus, I.L., Janeck, A.S, Sinclair, D., Wetzel, F,T,. (1999). Behavioral dimensions of adjustment in persons with chronic pain: pain-related anxiety and acceptance. *Pain, 80*, 283–289.
- McCracken, L.M., & Thompson, M. (2009). Components of mindfulness in patients with chronic pain. *J Psychopathol Beh, 31*, 75-82.
- McCracken, L.M., & Turk, D.C. (2002). Behavioural and cognitive-behavioural treatment for chronic pain: outcome, predictors of outcome, and treatment process. *Spine, 27*, 2564-2573.
- McCracken, L.M., & Velleman, S.C. (2010). Psychological flexibility in adults with chronic pain: A study of acceptance, mindfulness, and values-based action in primary care. *Pain, 148*, 141-147.
- McCracken, L.M., & Vowles, K.E. (2006). Acceptance of chronic pain. *Curr Pain Headache Rep, 10*(2), 90-94.
- McCracken, L.M., & Vowles, K.E. (2014). Acceptance and commitment therapy and mindfulness for chronic pain: model, process, and progress. *Am Psychol, 69*(2), 178-187.

- McCracken, L.M., Vowles, K.E., Eccleston, C. (2004). Acceptance of chronic pain: Component analysis and a revised assessment method. *Pain, 107*, 159-166.
- McCracken, L.M., Vowles, K.E. & Eccleston, C. (2005). Acceptance-based treatment for persons with complex, long standing chronic pain: a preliminary analysis of treatment outcome in comparison to a waiting phase. *Behav Res Ther, 43*, 1335-1346.
- McCracken, L.M., & Zhao-O'Brien, J. (2010). General psychological acceptance and chronic pain: there is more to accept than the pain itself. *Eur J Pain, 14*, 170-175.
- McCracken, L.M., & Yang, S. (2006). The role of values in a contextual cognitive-behavioral approach to chronic pain. *Pain, 123*, 137-145.
- McGoldrick, M., Pierce, J., Giordano, J. (1982). *Ethnicity and family therapy*. New York: Guildford Press.
- McQuay, H.J. (2002). Neuropathic pain: evidence matters. *Eur J Pain, 6(Suppl A)*, 11-18.
- Melzack, R. (2001). Pain and the neuromatrix in the brain. *J Dent Educ, 65(12)*, 1378-1382.
- Melzack, R., & Wall, P.D. (1965). Pain mechanisms: A new theory. *Sci, 150*, 971-979.
- Melzack, R., & Wall, P.D. (2003). *Handbook of Pain Management: A clinical companion to Wall and Melzack's Textbook of Pain*. Philadelphia: Churchill Livingstone.
- Merry, B., Edwards, R.R., Buenaver, L.F., McGuire, L., Haythornthwaite, J.A., Doleys, D.M., Campbell, C.M. (2011). Ethnic group differences in the outcomes of pain treatment. *J Musculoskelet Pain, 19(1)*, 24-30.

- Merskey, H. (1991). The definition of pain. *Eur Psychiatry*, 6, 153-159.
- Miller, L.R., Cano, A. (2009). Comorbid chronic pain and depression: who is at risk? *J Pain*, 10, 619-627.
- Ministry of Health, Singapore.^a Retrieved from <http://www.moh.gov.sg>. (Accessed 1st October 2015).
- Ministry of Health, Singapore.^b Retrieved from https://www.moh.gov.sg/content/moh_web/home/costs_and_financing/schemes_subsidies/medisave.html. (Accessed 1st March 2014).
- Mirza, S.K., & Deyo, R.A. (2007). Systematic review of randomized trials comparing lumbar fusion surgery to non-operative care for treatment of chronic back pain. *Spine*, 32, 816-823.
- Miyamoto, Y., Nisbett, R.E., Masuda, T. (2006). Culture and the physical environment: Holistic versus analytic perceptual affordances. *Psychol Sci*, 17, 113-119.
- Montgomerie, E. (1994). Support groups for chronic pain in Auckland. *J New Zealand Pain Soc*, 1994, 15-17.
- Moore, R.A., Chi, C.C., Wiffen, P.J., Derry, S., Rice, A.S. (2015). Oral nonsteroidal anti-inflammatory drugs for neuropathic pain. *Cochrane Database of Syst Rev*, Issue 10: CD010902. doi: 10.1002/14651858.CD010902.pub2.
- Moore, R.A., Derry, S., Taylor, R.S., Straube, S., Phillips, C.J. (2013). The costs and consequences of adequately managed chronic non-cancer pain and chronic neuropathic pain. *Pain Pract*, 14(1), 79-94.
- Morello, C..M., Leckband, S.G., Stoner, C.P., Moorhouse, D.F., Sahagian, G.A. (1999). Randomized double blind study comparing efficacy of gabapentin

- with amitriptyline on diabetic peripheral neuropathy pain. *Arch Intern Med*, 159, 1931–1937.
- Morgan, C.L., Conway, P., Currie, C.J. (2011). The relationship between self-reported severe pain and measures of socio-economic disadvantage. *Eur J Pain*, 15, 1107-1111.
- Morley, S. (2004). Process and change in cognitive behavior therapy for chronic pain. *Pain*, 109, 205-206.
- Morley, S. (2011). Efficacy and effectiveness of cognitive behavior therapy for chronic pain: progress and some challenges. *Pain*, 152(3)(Supp1), S99-S106.
- Morley, S., Eccleston, C., Williams, A. (1999). A systematic review and meta-analysis of randomized controlled trials of cognitive behavior therapy and behavior therapy for chronic pain in adults, excluding headache. *Pain*, 80, 1-13.
- Morley, S., & Williams, A.C. (2006). RCTs of psychological treatments for chronic pain: progress and challenges, *Pain*, 121, 171-172.
- Morone, N.E., Greco, C.M., Weiner, D.K. (2008). Mindfulness meditation for the treatment of chronic low back pain in older adults: a randomized controlled pilot study. *Pain*, 134, 310-319.
- Morris, M.W., & Peng, K. (1994). Culture and cause: American and Chinese attributions for social and physical events. *J Personality Soc Psychol*, 67, 949-971.
- Moulin, D.E., Clark, A.J., Speechley, M., Morley-Forster P.K. (2002). Chronic pain in Canada-prevalence, treatment, impact and the role of opioid analgesia. *Pain Res Manag*, 7, 179-184.

- Mullersdorf, M., Zander, V., Eriksson, H. (2011). The magnitude of reciprocity in chronic pain management: Experiences of dispersed ethnic populations of Muslim women. *Scand J Caring Sci*, 25(4), 637-645.
- Muto T, Hayes SC, Jeffcoat T. (2011). The effectiveness of acceptance and commitment therapy bibliotherapy for enhancing the psychological health of Japanese college students living abroad. *Behav Ther*, 4, 323-35.
- Nakumara, M., Nishiwaki, Y., Ushida, T., Toyama, Y. (2014). Prevalence and characteristics of chronic musculoskeletal pain in Japan: A second survey of people with or without chronic pain. *J Orthop Sci*, 19, 339-350.
- Nampiaparampil, D.E., Nampiaparampil, G.M., Nampiaparampil, R.G. (2012). Oral opioid analgesics vs spinal steroid injections in treatment of low back pain syndromes. *Am J Phys Med Rehabil*, 91, 162-176.
- National Institute for Health and Clinical Excellence (NICE). (2007) How to change practice: Understand, identify and overcome barriers to change (pp. 1-46). London: National Institute of Health and Clinical Excellence.
- National Pain Summit Initiative. National pain strategy: pain management for all Australians 2010. Retrieved from: <http://www.painaustralia.org.au>. (Accessed 5th March 2015).
- Naylor, M.R., Naud, S., Keefe, F.J., Helzer, J.E. (2010). Therapeutic Interactive Voice Response (TIVR) to reduce analgesic medication use for chronic pain management. *J Pain*, 11(12), 1410-1419.
- Neugebauer, V., Li, W., Bird, G.C., Han, J.S. (2004). The amygdala and persistent pain. *Neuroscientist*, 10, 221–234.
- Nicholas, M.K., Cardosa, M., Chen, P.P. (2006). Developing multidisciplinary Cognitive-Behavioral Pain Management Programs in Asia. In H. Flor. E. Kalso. Dostrovsky J.O (Eds.), *Proceedings of the 11th World Congress on*

- Pain, Progress in Pain Research and Management* (Vol 18, pp. 773-788).
Seattle: IASP Press.
- Niles, A.N., Burklund, L.J., Arch, J.J., Lieberman, M.D., Saxbe, D., Craske, M.G. (2014). Cognitive mediators of treatment for social anxiety disorder: Comparing acceptance and commitment therapy and cognitive-behavioral therapy. *Behav Ther*, *45*, 664-677.
- Nisbett, R.E. (2003). *The geography of thought: How Asian and Westerners think differently...and why*. New York: Free Press.
- Nisbett, R.E., Peng, K., Choi, I., Norenzayan, A. (2001). Culture and systems of thought: Holistic vs. analytic cognitions. *Psychol Rev*, *108*, 291-310.
- Noble, M., Treadwell, J.R., Tregear, S.J., Coates, V.H., Wiffen, P.J., Akafomo, C., Schoelles, K.M. (2010). Long-term opioid management for chronic non-cancer pain. *Cochrane Database Syst Rev*, *20(1)*, CD006605.
- Norenzayan, A., Choi, I., Peng, K. (2007). Cognition and perception. In S.Kitayama & D. Cohen (Eds.), *Handbook of cultural psychology* (pp. 569-594). New York: Guilford Press.
- Norenzayan, A., & Heine, S.J. (2005). Psychological universals: What are they and how can we know? *Psychol Bull*, *131(5)*, 763-784.
- O'Brien, T., & Breivik, H. (2012). The impact of chronic pain-European patients' perspective over 12 months. *Scand J Pain*, *3*, 23-29.
- Oh, H.Y., & Seo, W.S. (2005). Decreasing pain and depression in a health promotion program for people with rheumatoid arthritis. *J Nurs Scholarsh*, *35(2)*, 127-132.
- Oosterhof, B., Dekker, J.H.M., Sloots, M., Bartels, E.A., Dekker, J. (2014). Success or failure of chronic pain rehabilitation: the importance of good

- interaction-a qualitative study under patients and professionals. *Disabil Rehabil*, 36(22), 1903-1910.
- Osborn, M., & Rodham, K. (2010). Insights into pain: A review of qualitative research. *Rev Pain*, 4(1), 2-7.
- Oslund, S., Robinson, R.C., Clark, T.C. Garofalo, J.P., Behnk, P., Walker, B.,...Noe, C.E. (2009). Long-term effectiveness of a comprehensive pain management program: Strengthening the case for interdisciplinary care. *Proceedings (Baylor University Medical Center)*, 22(3), 211-214.
- Ost, L.-G. (2008). Efficacy of the third wave of behavioral therapies: A systematic review and meta-analysis. *Behav Res and Ther*, 46, 296-321.
- Paez-Blarrina, M., Luciano, C., Gutierrez-Martinez, O., Valdiva, A., Ortega, J., Valverde, M. (2008). The role of values with personal examples in altering the functions of pain: Comparison between acceptance-based and cognitive-control based protocols. *Behav Res Ther*, 46, 84-97.
- Pain proposal: Improving the current and future management of chronic pain. A European consensus report 2010. Retrieved from <https://www.pfizer.pt/Files/Billeder/Pfizer%20P%C3%BAblico/Not%C3%ADcias/Pain%20Proposal%20%20European%20Consensus%20Report%20final.pdf> (Accessed 28th May 2014).
- Parsons S, Harding G, Breen A, Foster N, Pincus T, Vogel S, Underwood M. (2007). The influence of patients and primary care practitioners' beliefs and expectations about chronic musculoskeletal pain on the process of care. *Clin J Pain*, 23, 91-98.
- Patel, A.S., Farquharson, R., Carroll, D., Moore, A., Phillips, C.J., Taylor, R.S., Barden, J. (2012). The impact and burden of chronic pain in the workplace: A qualitative systematic review. *Pain Pract*, 12, 578-589.

- Paulson, M., Danielson, E., Larsson, K., Norberg, R.N. (2001). Men's descriptions of their experience of non-malignant pain of fibromyalgia type. *Scand J Caring Sci*, 15(1), 54-59.
- Pennato, T., Berrocal, C., Bernini, O., Rivas, T. (2013). Italian version of the Acceptance and Action Questionnaire-II (AAQ-II): Dimensionality, reliability, convergent and criterion validity. *J Psychol Behav Assess*, 35(4), 552-563.
- Peolsson, M., Hyden, L.C., Sätterlund-Larsson, U. (2007). Living with chronic pain: a dynamic learning process. *Scand J Occup Ther*, 7, 114-125.
- Petrie, K.J., Frampton, T., Large, R.G., Moss-Morris, R., Johnson, M., Meechan, G.. (2005). What do patients expect from their visit to a pain clinic? *Clin J Pain*, 4, 297-301.
- Philips, H.C. (1987). Avoidance behaviour and its role in sustaining chronic pain. *Behav Res Ther*, 25, 273-279.
- Picavet, H.S., Vlaeyen, J.W., Schouten, J.S. (2002). Pain catastrophizing and kinesiophobia: predictors of chronic low back pain. *Am J Epidemiol*, 156, 1028-1034.
- Pillay, T., Adriaan van Zyl, H., Blackbeard, D. (2013). Chronic pain perception and cultural experience. *Procedia-Soc Behav Sci*, 113, 151-160.
- Pincus, T., Smeets, R.J., Simmonds, M.J., Sullivan, M.J. (2010). The fear avoidance model disentangled: improving the clinical utility of the fear avoidance model. *Clin J Pain*, 26, 739-746.
- Pinto, R.Z, Maher, C.G., Ferreira, M.L., Hancock, M., Oliveira, V.C., McLachlan, A.J,... Ferreira PH. (2012). Epidural corticosteroid injections in the management of sciatica: a systematic review and meta-analysis. *Ann Intern Med*, 157(12), 865-877.

- Pinto-Gouveia J., Gregorio, S., Dinis, A., Xavier, A. (2012). Experiential avoidance in clinical and non-clinical samples: AAQ-II Portuguese Version. *Int J Psychol Psychol Ther*, 12(2), 139-156.
- Powers, M.B., Zum Vorde Sive Vording, M.B., Emmelkamp, P.M.G. (2009). Acceptance and Commitment Therapy: A meta-analytic review. *Psychother and Psychosom*, 78, 73-80.
- Prochaska, J., DiClemente, C., Norcross, J. (1992). In search of how people change: application to addictive behaviors. *Am Psychol*, 47, 1102-1114.
- Quah, S.R. (1989). The best bargain: Medical options in Singapore. In S.R. Quah (Ed.), *The triumph of practicality: Tradition and modernity in health-care utilization in selected Asian countries* (pp.122-159). Singapore: Institute of Southeast Asian Studies.
- Rafferty, M.N., Sarma, K., Murphy, A.W., De la Harpe, D., Normand, C., McGuire, .B.E. (2011). Chronic pain in the Republic of Ireland-community prevalence, psychosocial profile and predictors of pain-related disability: results from the Prevalence, Impact and Cost of Chronic Pain (PRIME) study, part 1. *Pain*, 152, 1096-1103.
- Rainville, J., Carlson, N., Polatin, P., Gatchel, R.J., Indahl, A. (2000). Exploration of physician's recommendations for activities in chronic low back pain. *Spine*, 25, 2210-2220.
- Reid, K.J., Harker, J., Bala, M.M., Truyers, C., Kellen, E., Bekkering, G.E.,...Kleijnen, J. (2011). Epidemiology of chronic non-cancer pain in Europe: narrative review of prevalence, pain treatments and pain impact. *Curr Med Res Opin*, 27(2), 449-462.

- Reynoldson, C., Stones, C., Allsop, M., Gardner, P., Bennett, M.I., Closs, S.J., Knapp, P. (2014). Assessing the quality and usability of smartphone apps for pain self-management. *Pain Med*, 15, 898-909.
- Rice, A.S.C., Maton, S., NPS Group. (2001). Gabapentin in postherpetic neuralgia: A randomised, double blind, placebo controlled study. *Pain*, 94, 215–224.
- Ritchie J., & Spencer, L. (1994). Qualitative data analysis for applied policy research. In: A. Bryman A & R.D. Burges RD (Eds.), *Analysing Qualitative Data* (pp. 173-194). London: Routledge.
- Roberts, A.H. (1981). The behavioural treatment of pain: In J.M. Ferguson & C.B. Taylor (Eds.), *The Comprehensive Handbook of Behavioural Medicine*, vol 2: *Syndromes and Special Area*, Spectrum (pp. 171-189). New York: Jamaica.
- Roberts, A.H., & Reinhardt, L. (1980). The behavioural management of chronic pain: long-term follow-up with comparison groups. *Pain*, 8, 151-162.
- Rodero, B., Garcia-Campayo, J., Casaneuva, B., Lopez del Hoyo, Y., Serrano-Blanco, A., Luciano, J.V. (2010). Validation of the Spanish version of the Chronic Pain Acceptance Questionnaire (CPAQ) for the assessment of acceptance in Fibromyalgia. *Health Qual Life Outcomes*, 8, 37-46.
- Roelofs, P.D.D.M., Deyo, R.A., Koes, B.W., Scholten, R.J., van Tulder, M.W. (2008). Nonsteroidal anti-inflammatory drugs for low back pain: An updated Cochrane Review. *Spine*, 33 (16), 1766-1774.
- Roelofs, J., van Breukelen, G., Sluiter, J., Frings-Dresen, M.H., Goossens, M., Thibault, P.,...Vlaeyen, J.W. (2011). Norming of the Tampa Scale for

- Kinesiophobia across pain diagnoses and various countries. *Pain*, 152, 1090-1095.
- Roemer, L., & Orsillo, S.M. (2009). *Mindfulness-Acceptance-based behavioral therapies in practice*. New York: Guildford Press.
- Rogler, L.H. (1989). The meaning of culturally sensitive research in mental health. *Am J Psychiatry*, 146, 296-303.
- Rogler, L.H., Malgady, R.G., Constantino, G., Blumenthal, R. (1987). What do culturally sensitive mental health services mean? The case of Hispanics. *Am Psychol*, 42, 565-570.
- Rosenzweig, S., Greeson, J.M., Reibel, D.K., Green, J.S., Jasser, S.A., Beasley, D. (2010). Mindfulness-based stress reduction for chronic pain conditions: Variations in treatment outcomes and role of home meditation practice. *J Psychosom Res*, 68, 29-36.
- Rosser, B.A., & Eccleston, C. (2011). Smartphone applications for pain management. *J Telemed Telecare*, 17, 308-312.
- Rosser, B.A., Vowles, K.E., Keogh, E., Eccleston, C., Mountain, G.A. (2009). Technologically-assisted behaviour change: a systematic review of studies of novel technologies for the management of chronic illness. *J Telemed Telecare*, 15, 327-338.
- Rost, A.D., Wilson, K.G., Buchanan, E., Hildebrandt, M.J., Mutch, D. (2012). Improving psychological adjustment among late-stage ovarian cancer patients: Examining the role of avoidance in treatment. *Cogn Behav Pract*, 19(4), 508-517.
- Rovner, G.S., Arestedt, K., Gerdle, B., Borsbo, B., McCracken, L.M. (2014). Psychometric properties of the 8-item Chronic Pain Acceptance

- Questionnaire (CPAQ-8) in a Swedish chronic pain cohort. *J Rehabil Med*, 46(1), 73-80.
- Rozin, P. (2006). Domain denigration and process preference in academic psychology. *Perspect Psychol Sci*, 1, 365-376.
- Ruehlman, L.S., Karoly, P., Enders, C. (2012). A randomized controlled evaluation of an online chronic pain self management program. *Pain*, 153, 319-330.
- Ruiz, F.J. (2012). Acceptance and Commitment Therapy versus Traditional Cognitive Behavioral Therapy: A systematic review and meta-analysis of current empirical evidence. *Int J Psychol Psychol Ther*, 12(3), 333-357.
- Ruiz, F.J., Langer Herrera, A.I., Luciano, C., Cangas, A.J. (2013). Measuring experiential avoidance and psychological inflexibility: The Spanish version of the Acceptance and Action Questionnaire-II. *Psicothema*, 25(1), 123-129.
- Rumelhart, D.E., McClelland, J.L., PDP Research Group. (1986). *Parallel distributed processing: Explorations in the microstructure of cognition*. Cambridge, MA: MIT Press.
- Saarto, T., & Wiffen, P.J. (2007). Antidepressants for neuropathic pain. *Cochrane Database Syst Rev*, 4, CD005454.
- Salerno, S.M., Browning, R., Jackson, J.L. (2002). The effect of antidepressant treatment on chronic back pain: a meta-analysis. *Arch Intern Med*, 162, 19–24.
- Saltychev M, Eskola M, Laimi K. (2014). Lumbar fusion compared with conservative treatment in patients with chronic low back pain: a meta-analysis. *Int J Rehabil Res*, 37, 2–8.

- Savigny, P., Watson, P., Underwood, M. (2009). Early management of persistent non-specific low back pain: summary of NICE guidance. *BMJ*, 338, b1805.
- Schaefer, C., Chandran, A., Hufstader, M., Baik, R., McNett, M., Goldenberg, D.,...Zlateva, G. (2011). The comparative burden of mild, moderate and severe fibromyalgia: results from a cross-sectional survey in the United States. *Health Qual Life Outcomes*, 9, 71.
- Schers, H., Wensing, M., Huijsmans, Z., van Tulder, M., Grol, R. (2001). Implementation barriers for general practice guidelines on low back pain: A qualitative study. *Spine*, 26, 348-353.
- Schmidt, S., Grossman, P., Schwarzer, B., Jena, S., Naumann, J., Walach, H. (2011). Treating fibromyalgia with mindfulness-based stress reduction: results from a 3-armed randomized controlled trial. *Pain*, 152, 361-369.
- Scott, W., Daly, A., Lin, Y., McCracken, L.M. (2016). Treatment of chronic pain for adults 65 and over: analyses of outcomes and changes in psychological flexibility following interdisciplinary Acceptance and Commitment Therapy (ACT). *Pain Med*, <http://dx.doi.org/10.1093/pm/pnw073>.
- Scott, W., & McCracken, L.M. (2015). Psychological flexibility, acceptance and commitment therapy, and chronic pain. *Curr Opin Psychol*, 2, 91-96.
- Segal, Z., Williams, J.M.G., Teasdale, J.D. (2002). *Minfulness-based cognitive therapy for depression: A new approach to preventative relapse*. New York, NY: Guilford Press.
- Seminowicz, D.A., Wideman, T.H., Naso, L., Hatami-Khoroushahi, Z., Fallatah, S., Ware, M.A.,...Stone LS. (2011). Effective treatment of chronic low back pain in humans reverses abnormal brain anatomy and function. *J Neurosci*, 31(20), 7540-7550.

- Shealy, S., Mortimer, J.T., Reswick, J.B. (1967). Electrical inhibition of pain by stimulation of the dorsal columns: preliminary clinical report. *Anesth Analg*, 46, 489-491.
- Sheffer, C.E., Deisinger, J.A., Cassisi, J.E., Lofland, K. (2007). A revised taxonomy of patients with chronic pain. *Pain Med*, 8, 312-325.
- Shiotani M. (2001). Review and history of multidisciplinary pain clinic. *Pain Clin* 22, 606-616.
- Sim, J., & Adams, N. (2002). Systematic review of randomized controlled trials of nonpharmacological interventions for fibromyalgia. *Clin J Pain*, 18, 324-336.
- Simpson, E.L., Duenas, A., Holmes, M.W., Papaioannou, D., Chilcott, J. (2009). Spinal cord stimulation for chronic pain of neuropathic or ischemic origin: systematic review and economic evaluation. *Health Technol Assess*, 13, 1–154.
- Sindrup, S.H., Otto, M., Finnerup, N.B., Jensen, T.S. (2005). Antidepressants in the treatment of neuropathic pain. *Basic Clin Pharmacol Toxicol*, 96, 399-409.
- Singapore Psychological Society (SPS). Retrieved from <http://singaporepsychologicalsociety.org/singapore-register-of-psychologist/srp-directory> (Accessed 14th October 2015).
- Skinner, B.F. (1953). *Science and human behaviour*. New York, NY: McMillan.
- Skinner, B.F. (1974). *About Behaviorism*. New York: Vintage Books.
- Smith, T.B., Domenech, R.M., Bernal, G. (2011). Culture. *J Clin Psychol*, 67, 166-175.

- Soderberg, S., Lundman, B., Norberg, A. (2002). The meaning of fatigue and tiredness as narrated by women with fibromyalgia and healthy women. *J Clin Nurs*, 11(2), 247-255.
- Sorensen, G., Barbeau, E., Stoddard, A.M., Hunt, M.K., Kaphingst, K., Wallace, L. (2005). Promoting behavior change among working class, multi-ethnic workers: Results of the healthy directions-small business study. *Am J Public Health*, 95, 1389-1395.
- Spek, V., Cuijpers, P., Nyklíček, I., Riper, H., Keyzer, J., Pop, V. (2007). Internet-based CBT for symptoms of depression and anxiety: a meta-analysis. *Psychol Med*, 37(3), 319-328.
- Staal, J.B., Bie, R., de Vet, H.C.W., Hildebrandt, J., Nelemans, P. (2008). Injection therapy for subacute and chronic low back pain. *Cochrane Database Sys Rev*. doi: 10.1002/14651858.CD001824.pub3.
- Staiger, T.O., Gaster, B., Sullivan, M.D., Deyo, R.A. (2003). Systematic review of antidepressants in the treatment of chronic low back pain. *Spine*, 28, 2540-2545
- Steiner, J.L., Bogusch, L., Bigatti, S.M. (2013). Values-based action in fibromyalgia: Results from a randomized pilot of acceptance and commitment therapy. *Health Psychol Res*, 1(34), 176-181.
- Stoddard, J.A., & Afari, N. (2014). *The big book of ACT metaphors*. Oakland: New Harbinger Publications.
- Strauss, A., & Corbin, J. (1998). *Basics of qualitative research: techniques and procedures for developing grounded theory*, 2nd edn. London: Sage Publications.

- Subramaniam, V., Stewart, M.W., Smith, J.F. (1999). The development and impact of a chronic pain support group: A qualitative and quantitative study. *J Pain Symptom Manage*, 17, 376-383.
- Sue, S. (1999). Science, ethnicity, and bias. Where have we gone wrong? *Am Psychol*, 54, 1070-1077.
- Sue, S., & Zane, N. (1987). The role of culture and cultural techniques in psychotherapy. A critique and reformulation. *Am Psychol*, 42(1), 37-45.
- Sue, S., Zane, N., Nagayama Hall, G.C., Berger, L.K. (2009). The case for cultural competency in psychotherapeutic interventions. *Annu Rev Psychol*, 60, 525-548.
- Sullivan, M.D., Edlund, M.J., Fan, M-Y., Devries, A., Brennan Braden, J., Martin, B.C. (2008). Trends in use of opioids for non-cancer pain conditions 2000-2005 in commercial and Medicaid insurance plans: The TROUP Study. *Pain*, 138(2), 440-449.
- Sveinsdottir, V., Eriksen, H.R., Reme, S.E. (2012). Assessing the role of cognitive behavioral therapy in the management of chronic non-specific back pain. *J Pain Res*, 5, 371-380.
- Swain, J., Hancock, K., Dixon, A., Bowman, J. (2015). Acceptance and commitment therapy for children: A systematic review of intervention studies. *J Context Behav Sci*, 4, 73-85.
- Swartz, L.H.G., Noell, J.W., Schroeder, S.W., Ary, D.V. (2006). A randomised control study of a fully automated internet based smoking cessation programme. *Tob Control*, 15(1), 7-12.
- Takahashi, M., Muto, T., Tada, M., Sugiyama, M. (2002). Acceptance rationale and increasing pain tolerance: Acceptance-based and FEAR-based practice. *Jap J Behav Ther*, 28, 35-46.

- Talbot, J.D., Marret, S., Evans, A.C., Meyer, E., Bushnell, M.C., Duncan, G.H. (1991). Multiple representations of pain in human cerebral cortex. *Sci*, 251, 1355–1358.
- Tan, E.P.G., Tan, E.S.L., Ng, B.Y. (2009). Efficacy of Cognitive Behavioral Therapy for patients with chronic pain in Singapore. *Ann Acad Med Singapore*, 38, 952-959.
- Tan Tock Seng Hospital, Singapore. Pain Management Clinic (PMC) Internal Statistics. 2016, unpublished.
- Task Force on Guidelines for Desirable Characteristic for Pain Treatment Facilities. (1990). Desirable characteristics for pain treatment facilities. Washington, DC: International Association for the Study of Pain. Retrieved from <http://www.iasp-pain.org/AM/Template.cfm?Section=Home&Template=CM/HTMLDisplay.cfm&ContentID=3011>. (Accessed on 3rd September 2015).
- Taylor, C. (1989). *Sources of the self: The making of the modern identity*. Cambridge, MA: Harvard University Press.
- Taylor, S., Ellis, I., Gallagher, M. (2002). Patient satisfaction with a new physiotherapy telephone service for back pain patients. *Physiother*, 88, 645-657.
- Taylor, R.S., Ryan, J., O'Donnell, R., Eldabe, S., Kumar, K., North, R.B. (2010). The cost-effectiveness of spinal cord stimulation in the treatment of failed back surgery syndrome. *Clin J Pain*, 26(6), 463-469.
- Taylor, R.S., Van Buyten, J-P., Buchser, E. (2004). Spinal cord stimulation for chronic back and leg pain and failed back surgery syndrome: A systematic review and analysis of prognostic factors. *Spine*, 30(1), 152-160.

- Tharp, R.G. (1991). Cultural diversity and treatment of children. *J Consul Clin Psychol*, 59, 799-812.
- Thieme, K., Flor, H., Turk, D.C. (2006). Psychological pain treatment in fibromyalgia syndrome: efficacy of operant behavioural and cognitive behavioural treatments. *Arthritis Res Ther*, 8, R121.
- Thieme, K., & Gracely, R.H. (2009). Are psychological treatments effective for fibromyalgia pain? *Curr Rheumatol Rep*, 11, 443-450.
- Thieme, K., Gromnica-Ihle, E., Flor, H. (2003). Operant behavioural treatment of fibromyalgia: a controlled study. *Arthritis Rheum*, 49, 314-320.
- Thorsell, J., Finnes, A., Dahl, J., Lundgren, T., Gybrant, M., Gordh, T., Buhrman, M. (2011). A comparative study of 2 manual-based self-help interventions, acceptance and commitment therapy and applied relaxation for person with chronic pain. *Clin J Pain*, 27, 716-723.
- Thunberg, K.A., & Hallberg, L.R.M. (2002). The need for organizational development in pain clinics: A case study. *Disabil Rehabil*, 24, 755-762.
- Toneatto, T., & Nguyen, L. (2007). Does mindfulness meditation improve anxiety and mood symptoms? A review of the controlled research. *Can J Psych*, 52, 260-266.
- Torneke, N. (2010). *Learning RFT: An introduction to Relational Frame Theory and Its Clinical Application*. Canada: New Harbinger Publications.
- Tracey, I., & Mantyh, P.W. (2007). The cerebral signature for pain perception and its modulation. *Neuron*, 55(3), 377-391.
- Trompetter, H.R., Bohmeijer, E.T., Veehof, M.M., Schreurs, K.M. (2015a). Internet-based guided self-help intervention for chronic pain based on Acceptance and Commitment Therapy: a randomized controlled trial. *J Behav Med*, 38(1), 66-80.

- Trompetter, H.R., Bohmeijer, E.T., Fox, J.P., Schreurs, K.M.G. (2015b). Psychological flexibility and catastrophizing as associated change mechanisms during online Acceptance and Commitment Therapy for chronic pain. *Behav Res Ther*, 74, 50-59.
- Trompetter, H.R., Ten Klooster, P.M., Schreurs, K.M., Fledderus, M., Westerhof, G.J., & Bohlmeijer, E.T. (2013). Measuring values and committed action with the Engaged Living Scale (ELS): Psychometric evaluation in a nonclinical sample and a chronic pain sample. *Psychol Assessment*, 25, 1235-1246.
- Tse, M.M.Y., Vong, S.K.S., Tang, S.K. (2013). Motivational interviewing and exercise programme for community-dwelling older persons with chronic pain: a randomised controlled study. *J Clin Nurs*, 22, 1843-1856.
- Tucker, C.M., Marsiske, M., Rice, K.G., Jones, J.D., Herman, K.C. (2011). Patient-centered culturally sensitive health care: model testing and refinement. *Health Psychol*, 30(3), 342-350.
- Turk, D.C., Meichenbaum, D., Genest, M. (1983). *Pain and behavioural medicine: A cognitive-behavioral perspective*. New York: Guilford Press.
- Turk, D.C. (1996). *Biopsychosocial perspective on chronic pain*. In R.J. Gatchel & D. Turk (Eds.), *Psychological approaches to pain management: A practitioner's handbook* (pp. 3-32). New York: Guilford.
- Turk, D.C. (2002). Clinical effectiveness and cost-effectiveness of treatments for patients with chronic pain. *Clin J Pain*, 18, 355-365.
- Turk, D.C. (2003). Cognitive-behavioral approach to the treatment of chronic pain patients. *Region Anesth Pain Med*, 28, 573-579.
- Turk, D.C., Dworkin, R.H., Revicki, D., Harding, G., Burke, L.B., Cella D.,...Rappaport B.A. (2008). Identifying important outcome domains for

- chronic pain clinical trials: An IMMPACT survey of people with pain. *Pain*, 137, 276-285.
- Turk, D.C., Meichenbaum, D., Genest, M. (1983). *Pain and behavioral medicine: A Cognitive-Behavioral perspective*. New York: Guildford Press.
- Turk, D.C., & Okifuji, A. (1997). Evaluating the role of physical, operant, cognitive and affective factors in the pain behaviours of chronic pain patients. *Behav Modif*, 21, 259-280.
- Turk, D.C., Robinson, J.P., Burwinkle, T. (2004). Prevalence of fear of pain and activity in patients with fibromyalgia syndrome. *J Pain*, 5(9), 483-490.
- Turk, D.C., & Rudy, T.E. (1988). Toward an empirically derived taxonomy of chronic pain patients: integration of psychological assessment data. *J Consult Clin Psychol*, 56, 233-238.
- Turk, D.C., Swanson, K.S., Tunks, E.R. (2008). Psychological approaches in the treatment of chronic pain patients-When pill, scalpels, and needles are not enough. *Can J Psychiat*, 53(4), 213-223.
- Turk, D.C., & Theodore, B.R. (2010). Epidemiology and economics of chronic and recurrent pain, In M.E. Lynch, K.D. Craig, P.W.H. Peng (Eds.), *Clinical pain management: A practical guide* (pp. 6-13). West Sussex, UK: Wiley-Blackwell.
- Turk, D.C., & Wilson, H.D. (2010). Fear of pain as a prognostic factor in chronic pain: Conceptual models, assessment, and treatment implications. *Curr Pain Headache Rep.*, 14(2), 88-95.
- Turk, D.C., & Winter, F. (2006). *The Pain Survival Guide: How to Reclaim Your Life*. New York: American Psychological Association.

- Turner, J.A., Clancy, S., McQuade, K.J., Cardenas, D.D. (1990). Effectiveness of behavioural therapy for chronic low back pain: a component analysis. *J Consult Clin Psychol*, 58, 573-579.
- Turner, J., Holtzman, S., Mancl, L. (2007). Mediators, moderators and predictors of therapeutic change in cognitive-behavioural therapy for chronic pain. *Pain*, 127, 276-286.
- Turner, J.A., Mancl, L., Aaron, L.A. (2005). Brief cognitive-behavioral therapy for temporomandibular disorder pain: effects on daily electronic outcome and process measures. *Pain*, 117(3), 377-387.
- Turner, J.A., Mancl, L., Aaron, L.A. (2006). Short- and long-term efficacy of brief cognitive-behavioral therapy for patients with chronic temporomandibular disorder pain: a randomized, controlled trial. *Pain*, 121(3), 181-194.
- Twohig, M.P. (2012). Introduction: The basics of Acceptance and Commitment Therapy. *Cogn Behav Pract*, 19(4), 499-618.
- Twohig, M.P., Hayes, S.C., Plumb, J.C., Pruitt, L.D., Collins, A.B., Hazlett-Stevens, H.,...Woidneck, M.R. (2010). A randomized clinical trial of acceptance and commitment therapy vs. progressive relaxation training for obsessive compulsive disorder. *J Consul Clin Psychol*, 78, 705-716.
- Urquhart, D.M., Hoving, J.L., Assendelft, W.W., Roland, M., van Tulder, M.W. (2008). Antidepressants for non-specific low back pain. *Cochrane Database Syst Rev*, 23(1), CD001703. doi: 10.1002/14651858.CD001703.pub3.
- Valjakka, A.L., Salanterä, S., Laitila, A., Julkunen, J., Hagelberg, N.M. (2013). The association between physicians' attitudes to psychosocial aspects of low back pain and reported clinical behaviour: A complex issue. *Scand J Pain*, 4, 25-30.

- Vallejo, R., Varkin, R.L., Wang, V.C. (2011). Pharmacology of opioids in the treatment of chronic pain syndromes. *Pain Phy*, 14, E343-360.
- Vannemreddy, P., & Slavin, K.V. (2011). Spinal cord stimulation: Current applications for treatment of chronic pain. *Anesth Essays Res*, 5, 20-27.
- van Tulder, M., Becker, A., Bekkering, T., Breen, A., del Real, M.T., Hutchinson, A.,... COST B13 Working Group on Guidelines for the Management of Acute Low Back Pain in Primary Care. (2006). Chapter 3. European guidelines for the management of acute nonspecific low back pain in primary care. *Eur Spine J*, 15(Suppl 2), S169–S191.
- van Tulder, M.W., Koes, B., Malmivaara A. (2006). Outcome of non-invasive treatment modalities on back pain: an evidence based review. *Eur Spine J*, 15(Suppl 1), S64–S81.
- van Tulder, M.W., Ostelo, R.W.J.G., Vlaeyen, J.W.S., Linton, S.J., Morley, S.J., Assendelft, W.J. (2000). *Behavioural treatment for chronic low back pain: a systematic review within the framework of the Cochrane Back Review Group. Spine (Phila Pa 1976)*, 25(20), 2688-2699.
- Varra, A.A., Hayes, S.C., Roget, N., Fisher, G. (2008). A randomized control trial examining the effect of acceptance and commitment training on clinician willingness to use evidence-based pharmacotherapy. *J Consul Clin Psychol*, 76(3), 449-458.
- Veehof, M.M., Oskam, M.-J., Schreurs, K.M., Bohlmeijer, E.T. (2011). Acceptance-based intervention for the treatment of chronic pain: a systematic review and meta-analysis. *Pain*, 152, 533-542.
- Veehof, M.M., Trompetter, H.R., Bohlmeijer, E.T., Schreurs, K.M.G. (2016). Acceptance and mindfulness-based interventions for the treatment of chronic pain: a meta-analytic review. *Cogn Behav Ther*, 45(1), 5-31.

- Verbeek J, Sengers M-J, Riemens L, Haafkens J. (2004). Patient expectations of treatment for back pain: A systematic review of qualitative and quantitative studies. *Spine*, 29(20), 2309-2318.
- Verbunt, J.A., Huijnen, I.P., Koke, A. (2009). Assessment of physical activity in daily life in patients with musculoskeletal pain. *Eur J Pain*, 13, 231-242.
- Viane, I., Crombez, C., Eccleston, C., Devulder, J., De Corte, W. (2004). Acceptance of the unpleasant reality of chronic pain: effects upon attention to pain and engagement with daily activities. *Pain*, 112(3), 282-288.
- Viane, I., Crombez, G., Eccleston, C., Poppe, C., Devulder, J., Van Houdenhove, B...De Corte W. (2003). Acceptance of pain is an independent predictor of mental well-being in patients with chronic pain: empirical evidence and reappraisal. *Pain*, 106, 65-72.
- Vlaeyen, J.W., & Crombez, G. (1999). Fear of movement/(re)injury, avoidance and pain disability in chronic low back pain patients. *Man Ther*, 4(4), 187-195.
- Vlaeyen, J.W.S., de Jong, J., Geilen, M., Heuts, P.H., van Breukelen, G. (2001). Graded exposure *in vivo* in the treatment of pain related fear: a replicated single-case experimental design in four patients with chronic low back pain. *Behav Res Ther*, 39, 151-166.
- Vlaeyen, J.W., Kole-Snijders, A., Rotteveel, A., Ruesink, R., Heuts, P.H. (1995). The role of fear of movement/ (re)injury in pain disability. *J Occup Rehabil*, 5, 235-252.
- Vlaeyen, J.W.S., & Linton, S.J. (2000). Fear-avoidance and its consequences in chronic musculoskeletal pain: a state of the art. *Pain*, 85, 317-332.
- Vlaeyen, J.W.S., & Linton, S.J. (2012). Fear-avoidance model of chronic musculoskeletal pain: 12 years on. *Pain*, 153(6), 1144-1147.

- Vlaeyen, J.W.S., & Morley, S. (2005). Cognitive-behavioural treatments for chronic pain: what works for whom? *Clin J Pain, 21*, 1-8.
- Von Korff, M., Ormel, J., Keefe, F.J., Dworkin, S.F. (1992). Grading the severity of chronic pain. *Pain, 50*, 133-149.
- Vong, S.K., Cheing, G.L., Chan, F., So, E.M., Chan CC. (2011). Motivational enhancement therapy in addition to physical therapy improves motivational factors and treatment outcomes in people with low back pain: A randomized controlled trial. *Arch Phys Med Rehabil, 92*, 176-183.
- Vowles, K.E., & McCracken, L.M. (2008). Acceptance and values-based action in chronic pain: a study of treatment effectiveness and process. *J Consult Clin Psychol, 76(3)*, 397-407.
- Vowles, K.E., & McCracken, L.M. (2010). Comparing the role of psychological flexibility and traditional pain management coping strategies in chronic pain treatment outcomes. *Behav Res Ther, 48*, 141-146.
- Vowles, K.E., McCracken, L.M., Zhao-O'Brien, J. (2011). Acceptance and values-based action in chronic pain: A three year follow-up analysis of treatment effectiveness and process. *Behav Res Ther, 49*, 748-755.
- Vowles, K.E., McNeil, D.W., Gross, R.T., McDaniel, M.L., Mouse, A. (2007). Effects of pain acceptance and pain control strategies on physical impairment in individuals with chronic low back pain. *Behav Ther, 38*, 412-425.
- Vowles, K.E., Wetherell, J.L., Sorrell, J.T. (2009). Targeting acceptance, mindfulness, and values-based action in chronic pain: Findings of two preliminary trials of an outpatient group-based intervention. *Cogn Behav Pract, 16*, 49-58.
- Vowles, K.E., Witkiewitz, K., Sowden, G., Ashworth, J. (2014). Acceptance and commitment therapy for chronic pain: evidence of mediation and clinically

- significant change following an abbreviated interdisciplinary program of rehabilitation. *J Pain*, 15(1), 101-113.
- Waddell, G., Newton, M., Henderson, I., Somerville, D., Main, C.J. (1993). A Fear-Avoidance Beliefs Questionnaire (FABQ) and the role of fear-avoidance beliefs in chronic low back pain and disability. *Pain*, 52, 157-168.
- Walker, J., Sofaer, B., Holloway, I. (2006). The experience of chronic back pain: Accounts of loss in those seeking help from pain clinics. *Eur J Pain*, 10, 199-207.
- Wall, P.D. (1979). On the relation of injury to pain. *Pain*, 6, 253-264.
- Wampold, B.E. (2001). *The great psychotherapy debate: models, methods, and findings*. Mahwah, NJ: Lawrence Erlbaum Associates.
- Wampold, B.E., & Serlin, R.C. (2000). The consequence of ignoring a nested factor on measures of effect size in analysis of variance. *Psychol Methods*, 5(4), 425-433.
- Washington, E.D., & McLoyd, V. (1982). The external validity of research involving American minorities. *Hum Dev*, 25, 324-339.
- Wertli, M.M., Rasmussen-Barr, E., Held, U., Weiser, S., Bachmann, L.M., Brunner, F. (2014). Fear-avoidance beliefs-a moderator of treatment efficacy in patients with low back pain: a systematic review. *Spine J*, 14(11), 2658-2678.
- Wetherell, J.L., Afari, N., Rutledge, T., Sorrell, J.T., Stoddard, J.A., Petkus, A.J.,...Atkinson, J.H. (2011). A randomized, controlled trial of acceptance and commitment therapy and cognitive-behavioral therapy for chronic pain. *Pain*, 152, 2098-2107.

- White, A.P., Arnold, P.M., Norvell, D.C., Ecker, E., Fehlings, M.G. (2011). Pharmacological management of chronic low back pain: synthesis of the evidence. *Spine*, 36 (21S), S131-S143.
- Whiting, D.L., Deane, F.P., Ciarrochi, J., McLeod, H.J., Simpson, G.K. (2014). Validating measures of psychological flexibility in a population with acquired brain injury. *Psychol Assess*, 27(2), 415-423.
- WHO. World Health Organization. The innovative care for chronic condition (ICCC); 2010. Retrieved from <http://www.who.int/diabetesactiononline/about/ICC/en/index.html>. (Accessed September 2013).
- Wicksell, R.K., Ahlqvist, J., Bring, A., Melin, L., Olsson, G.L. (2008). Can exposure and acceptance strategies improve functioning and life satisfaction in people with chronic pain and whiplash-associated disorders (WAD)? A randomized controlled trial. *Cogn Behav Ther*, 38, 169-182.
- Wicksell, R.K., Kemani, M., Jensen, K., Kosek, E., Kadetoff, D., Sorjonen, K.,...Olsson GL. (2013). Acceptance and commitment therapy for fibromyalgia: A randomized controlled trial. *Eur J Pain*, 17, 599-611.
- Wicksell, R.K., Melin, L., Olsson, G.L. (2007). Exposure and acceptance in the rehabilitation of adolescents with idiopathic chronic pain-A pilot study. *Eur J Pain*, 11, 779-787.
- Wicksell, R.K., Olsson, G.L., Hayes, S.C. (2010). Psychological flexibility as a mediator of improvement in Acceptance and Commitment Therapy for patients with chronic pain following whiplash. *Eur J Pain*, 14(10), 1059.e1-1059.e11.
- Wicksell, R.K., Olsson, G.L., Hayes, S.C. (2011). Mediators of change in acceptance and commitment therapy for paediatric chronic pain. *Pain*, 152(12), 2792-2801.

- Wideman, T.H., Adams, H., Sullivan, M.J. (2009). A prospective sequential analysis of the fear-avoidance model of pain. *Pain*, 145, 45-51.
- Wideman, T.H., Asmundson, G.G.J., Smeets, R.J.E.M., Zautra, A.J., Simmonds, M.J., Sullivan, M.J.L.,...Edwards, R.R. (2013). Re-thinking the Fear Avoidance Model: Toward a multi-dimensional framework of pain-related disability. *Pain*, 154(11), 2262–2265.
- Wiffen, P.J., McQuay, H.J., Edwards, J.E., Moore, R.A. (2005). Gabapentin for acute and chronic pain. *Cochrane Database Syst Rev*, 20(3), CD005452.
- Winbush, N.Y., Gross, C.R. Kreitzer, M.J. (2007). The effects of mindfulness-based stress reduction on sleep disturbance: A systematic review. *EXPLORE: J Sci Heal*, 3, 585-591.
- Williams, D.A. (2011). Web-based behavioral interventions for the management of chronic pain. *Curr Rheumatol Rep*, 13, 543-549.
- Williams, A.C.D.C., Eccleston, C., Morley, S. (2012). Psychological therapies for the management of chronic pain (excluding headache) in adults (Review). *Cochrane Database Sys Rev issue 11*, CD007407.
<http://www.onlinelibrary.wiley.com/10.1002/14651858.CD007407.pub3>.
- Williams, D.A., Keefe, F.J. (1991). Pain beliefs and the use of cognitive-behavioral coping strategies. *Pain*, 46, 185-190.
- Williams, D.A., Kuper, D., Segar, M., Mohan, N., Sheth, M., Clauw, D.J. (2010). Internet-enhanced management of fibromyalgia: a randomized controlled trial. *Pain*, 151, 694-702.
- Williams, D.R., & Rucker, T.D. (2000). Understanding and addressing racial disparities in health care. *Health Care Financ R*, 21, 75-90.
- Winkleby, M., Howard-Pitney, B., Albright, C., Bruce, B., Kraemer, H., Fortmann, S. (1997). Predicting achievement of a low-fat diet: A nutrition

- intervention for adults with low literacy skills. *Prevent Med: An International Journal Devoted to Practice and Theory*, 26, 874-882.
- Witkiewitz, K., Marlatt, A. G., Walker, D. (2005). Mindfulness-based relapse prevention for alcohol and substance use disorders, *J Cogn Psychoth*, 19(3), 211-228.
- Woidneck, M.R., Pratt, K.M., Gundy, J.M., Nelson, C.R., Twohig, M.P. (2012). Exploring cultural competence in acceptance and commitment therapy outcomes. *Prof Psychol Res Pr*, 43(3), 227-233.
- Wong, S.Y.S., Chan, F.W.K., Wong, R.L.P., Chu, M.C., Lam, Y.Y.K., Chu, M.C. (2011). Comparing the effectiveness of mindfulness-based stress reduction and multidisciplinary intervention programs for chronic pain- A randomised comparative trial. *Clin J Pain*, 27(8), 724-734.
- Wong, W.S., McCracken, L.M., Wong, S., Chen, P.P., Chow, Y.F., Fielding, R. (2016). The Chinese version of the 8-item Committed Action Questionnaire (ChCAQ-8): A preliminary analysis of the factorial and criterion validity. *Psychol Assess*, 28(6), e111-e118.
- Woolf, A.D. & Pfleger, B. (2003). Burden of major musculoskeletal conditions. *Bull World Health Organ*, 81(9), 646-656.
- Yang, S.Y., Bogosian, A., Moss-Morris, R., McCracken, L.M. (2015). Mixed experiences and perceptions of psychological treatment for chronic pain in Singapore: Skepticism, ambivalence, satisfaction, and potential. *Pain Med*, 16(7), 1290-300.
- Yang, S.Y., Bogosian, A., Moss-Morris, R., McCracken, L.M. (2016b). Health professionals' perceptions of psychological treatment for chronic pain in Singapore: Challenges, barriers and the way forward. *Disabil Rehabil*, 38(17), 1643-1651.

- Yang, S.Y., & McCracken, L.M. (2014). Acceptance and Commitment Therapy for chronic pain. *JCOM*, 21(3), 134-144.
- Yang, S.Y., McCracken, L.M., Moss-Morris, R. (2016a). Psychological treatments for chronic pain in East and Southeast Asia: A systematic review. *Int J Behav Med*, 23(4), 473-484.
- Yang, S.Y., Moss-Morris, R., McCracken, L.M. (2016c). Psychological treatment needs of people with chronic pain in Singapore and relevance of the psychological flexibility model. *Pain Med*, <http://dx.doi.org/10.1093/pm/pnw175>.
- Yang, S.Y., Moss-Morris, R., McCracken, L.M. (unpublished). iACT-CEL: A Feasibility Trial of a Face-to-Face and Internet-based Acceptance and Commitment Therapy (ACT) intervention for Chronic Pain in Singapore. (Manuscript under review for publication).
- Yeo, S.N., & Tay, K.H. (2009). Pain prevalence in Singapore. *Ann Acad Med Singapore*, 38(11), 937-942.
- Yip, Y.B., Sit, J.W.H., Wong, D.Y.S. (2004). A quasi-experimental study on improving arthritis self-management for residents of an aged people's home in Hong Kong. *Psychol Health Med*, 9(2), 235-246.
- Yip, Y.B., Sit, J.W., Fung, K.K.Y., Wong, D.Y.S., Chong, S.Y.C., Chung, L.H., Ng, T.P. (2007). Impact of an arthritis self-management programme with an added exercise component for osteoarthritic knee sufferers on improving pain, functional outcomes, and use of health care services: An experimental study. *Patient Educ Couns*, 65, 113-121.
- Zajacka, J., Tracy, K.A., Mitchell, S. (1997). Discontinuation symptoms after treatment with serotonin reuptake inhibitors: a literature review. *J Clin Psychiatry*, 58, 291-297.

- Zettle, R.D., & Hayes, S.C. (1986). Dysfunctional control by client verbal behavior. The context of reason giving. *Anal Verbal Behav*, 4, 30-38.
- Zettle, R.D., & Rains, J.C. (1989). Group cognitive and contextual therapies in treatment of depression. *J Clin Psychol*, 45, 438-445.
- Zettle, R.D., Rains, J.C., Hayes, S.C. (2011). Processes of change in acceptance and commitment therapy and cognitive therapy for depression: a mediation reanalysis of Zettle and Rains. *Behav Modif*, 35(3), 265-283.
- Zhang, C.Q., Chung, P.K., Si, G., Liu, J.D. (2014). Psychometric Properties of the Acceptance and Action Questionnaire-II for Chinese college students and elite Chinese athletes. *Measure Eval Counsel Dev*, 47, 256-270.

Appendix A. Chapter 7: Participant Informed Consent Form

INFORMED CONSENT FORM

1. Study Information

Protocol Title:

A feasibility study of Acceptance and Commitment Therapy (ACT) for chronic pain in Singapore-Phase 1 and 2.

Principal Investigator & Contact Details:

Yang Su-Yin
Pain Management Clinic, Tan Tock Seng Hospital, 11 Jalan Tan Tock Seng,
Singapore 308433
Tel: 6357 8352 (0), e-mail: su_yin_yang@ttsh.com.sg

2. Purpose of the Research Study

You are invited to participate in a research study. It is important to us that you first take time to read through and understand the information provided in this sheet. Nevertheless, before you take part in this research study, the study will be explained to you and you will be given the chance to ask questions. After you are properly satisfied that you understand this study, and that you wish to take part in the study, you must sign this informed consent form. You will be given a copy of this consent form to take home with you.

This study is carried out to find out the barriers to psychological treatment for physical health in Singapore from a healthcare professional and patient perspective. Such issues are not well understood in Singapore but important issues to identify and address especially with the prevalence of chronic diseases, a high incidence of chronic pain, and increasing interest in a more holistic approach to treatment, in Singapore. Information from this important study will be useful for addressing issues that affect treatment and enhancing patients' experience and at the pain management clinic.

This study is divided into 2 phases. Phase 1 will recruit 30 subjects (15 who are healthcare professionals and 15 who are patients) and phase 2 will recruit 200 subjects who are chronic pain sufferers from over a period of 12 months. About 230 subjects will be involved in this study. All patient subjects for Phase 1 will be recruited from the pain management clinic at Tan Tock Seng Hospital and all patient subjects from Phase 2 will be recruited from both the pain management clinic at Tan Tock Seng Hospital and through online web-based surveys (for patients not in specialist care).

3. What procedures will be followed in this study

You have been selected to take part in:

- Phase 1
- Phase 2

If you take part in **phase 1**, you will be asked to take part in a face-to-face interview where your responses regarding your experience with the current chronic pain service in Singapore will be audio taped via a digital voice recorder. There will be no

identifiers linked to your responses, audio taping the session allows the principal investigator to code the answers into general themes after all the interviews are completed.

If you take part in **phase 2** of this study, you will be asked to complete an anonymous survey as well as to fill up a series of questionnaires related to your pain and daily functioning.

Your participation in the study will last *approximately 1hr for phase 1 and 20 mins for Phase 2*. You are not required to spend more time participating other than the time you commit to the study today.

If you agree to take part in this study, one of the following will happen to you:

Phase 1: Face-to-face interview with an audio taping of your responses.

Phase 2: Complete a pen and paper anonymous survey and a series of pen and paper questionnaires.

These survey and questionnaires include the following:

1. A general questionnaire on patient demographics.
2. A survey on treatment barriers and treatment needs.
3. Patients' self-report pain score will be assessed via a numerical pain rating scale of 0-10.
4. Healthcare usage
5. Brief Pain Inventory (BPI) – interference scale which measures the amount of pain interference in a variety of daily activities.
6. The Patient Health Questionnaire-9 (PHQ-9) to measure depression.
7. Committed Action Questionnaire (CAQ) – a measure of psychological flexibility.
8. Acceptance and Action Questionnaire-2 (AAQ-2) which is a general measure of general psychological acceptance.
9. Chronic Pain Acceptance Questionnaire (CPAQ) which measures “activity engagement” and “pain willingness”.

4. Your Responsibilities in This Study

If you agree to participate in this study, you should follow the advice given to you by the study team. You should be prepared to visit the hospital once and undergo all the procedures that are outlined above. It is your responsibility to complete the interview and surveys/questionnaires given to you according to which study phase you have been recruited for.

5. What Is Not Standard Care or Experimental in This Study

The interviews in Phase 1 of this study and the questionnaire pack in Phase 2 which includes a survey and standardised measures are not part of standard care.

6. Possible Risks and Side Effects

Healthcare Provider Participants: There are no potential risks or side effects related to your participation in this study as it is only an oral interview.

Patient Participants: There are no potential risks or side effects related to your participation in this study. There will be no invasive procedures and you will still undergo treatment as usual with your primary pain specialist. Your answers and responses in the interviews or the survey and questionnaires have no bearing on your treatment at the pain management clinic.

7. Possible Benefits from Participating in the Study

There is no assurance you will benefit from participation in this study. However, your participation in this study may add to the medical knowledge about the barriers to psychological treatment in Singapore. This knowledge will help us in developing a treatment trial to improve cost effectiveness and treatment access for psychological intervention in Phase 3 of this study, hence catering for a new treatment option that will be available to you.

8. Important Information for Women Subjects

Not applicable.

9. Alternatives to Participation

Healthcare Provider Participants: You can choose not to take part in this study. There are no alternatives to not participating in this study.

Patient Participants: If you choose not to take part in this study, you will receive standard care for your condition. In our institution this would be continued treatment and recommendations by your pain specialist.

10. Costs & Payments if Participating in the Study

There are no costs and payments involved in participating in this study.

11. Voluntary Participation

Healthcare Provider Participants: Your participation in this study is voluntary. You may stop participating in this study at any time. You will not be penalised or lose any benefits which you are entitled to if you choose not to participate or stop participation in the study. If you decide to stop taking part in this study, you should tell the Principal Investigator.

Patient Participants: Your participation in this study is voluntary. You may stop participating in this study at any time. Your decision not to take part in this study or to stop your participation will not affect your medical care or any benefits to which you are entitled. If you decide to stop taking part in this study, you should tell the Principal Investigator.

Your doctor, the Investigator and/or the Sponsor of this study may stop your participation in the study at any time if they decide that it is in your best interests. They may also do this if you do not follow instructions required to complete the study adequately. If you have other medical problems or side effects, the doctor and/or nurse will decide if you may continue in the research study.

In the event of any new information becoming available that may be relevant to your

willingness to continue in this study, you (*or your legally acceptable representative, if relevant*) will be informed in a timely manner by the Principal Investigator or his/her representative.

12. Compensation for Injury

If you follow the directions of the doctors in charge of this study and you are physically injured due to the trial substance or procedure given under the plan for this study, Tan Tock Seng Hospital will pay the medical expenses for the treatment of that injury.

Payment for management of the normally expected consequences of your treatment will not be provided by Tan Tock Seng Hospital.

Tan Tock Seng Hospital, without legal commitment will compensate you for the injuries arising from your participation in the study without you having to prove Tan Tock Seng Hospital is at fault. There are however conditions and limitations to the extent of compensation provided. You may wish to discuss this with your Principal Investigator.

By signing this consent form, you will not waive any of your legal rights or release the parties involved in this study from liability for negligence.

13. Confidentiality of Study and Medical Records

Information collected for this study will be kept confidential. Your records, to the extent of the applicable laws and regulations, will not be made publicly available.

However, the NHG Domain-Specific Review Board and Ministry of Health will be granted direct access to your original medical records to check study procedures and data, without making any of your information public. By signing the Informed Consent Form attached, you (*or your legally acceptable representative, if relevant*) are authorizing such access to your study and medical records.

Data collected and entered into the Case Report Forms are the property of Tan Tock Seng Hospital. In the event of any publication regarding this study, your identity will remain confidential.

14. Who To Contact if You Have Questions

If you have questions about this research study, you may contact the Principal Investigator, Yang Su-Yin, Pain Management Clinic, Tan Tock Seng Hospital, 11 Jalan Tan Tock Seng, Singapore 308433. Tel: 6357 8352 (0), e-mail: su_yin_yang@ttsh.com.sg

In case of any injuries during the course of this study, you may contact the Principal Investigator, Yang Su-Yin (Tel: 6357 8352).

The study has been reviewed by the NHG Domain Specific Review Board (the central ethics committee) for ethics approval.

If you want an independent opinion of your rights as a research subject you may contact the NHG Domain Specific Review Board Secretariat at 6471-3266.

If you have any complaints about this research study, you may contact the Principal Investigator or the NHG Domain Specific Review Board Secretariat.

CONSENT FORM

Protocol Title:

A feasibility study of Acceptance and Commitment Therapy (ACT) for chronic pain in Singapore-Phase 1 and Phase 2.

Principal Investigator & Contact Details:

Yang Su-Yin, Pain Management Clinic, Tan Tock Seng Hospital, 11 Jalan Tan Tock Seng, Singapore 308433, Tel: 6357 8352 (0), e-mail: su_yin_yang@ttsh.com.sg.

I voluntarily consent to take part in this research study. I have fully discussed and understood the purpose and procedures of this study. This study has been explained to me in a language that I understand. I have been given enough time to ask any questions that I have about the study, and all my questions have been answered to my satisfaction.

Name of Participant

Signature

Date

Witness Statement

I, the undersigned, certify to the best of my knowledge that the participant signing this informed consent form had the study fully explained in a language understood by him / her and clearly understands the nature, risks and benefits of his / her participation in the study.

Name of Witness

Signature

Date

Investigator Statement

I, the undersigned, certify that I explained the study to the participant and to the best of my knowledge the participant signing this informed consent form clearly understands the nature, risks and benefits of her participation in the study.

Name of Investigator /
Person administering consent

Signature

Date

Appendix B. Chapter 7: Coding Manual for Participant Codes (Patients)

Themes	Subtheme Labels and Definitions	Example of Codes (by participant and line number)
<p>Expectations and Realities of Health Professionals</p>	<p>Communication Style</p> <p>Patients described their experience communicating with their health professionals and expressed their expectation of health professionals' style of communication in consult</p>	<p>P9“56 <i>how frustrated you feel about it at least you have someone to share with and to tell and they can</i> 57<i>actually propose certain ways to deal with it.</i>”</p> <p>P10“5 <i>Finally I managed to have a doctor who is empathetic enough to listen instead of just prescribing and then sending me out of the door...</i>”</p> <p>P12 “<i>I think more people concerned about you lah , this is a very</i> 174 <i>important ...support, telling you no doubt the pain you are suffering...but you</i> 175 <i>are not alone.</i>”</p> <p>Examples of negative codes</p> <p>P6 “<i>Then they tell you nothing. Nothing means I don't have to tell much then I don't get criticise</i> 261<i>much then you don't have to tell me what to do.</i>”</p> <p>P7“97...<i>health professionals do you understand? You don't understand what I mean when I say oh when I sit here I'm even talking to you I'm having this spasm...you don't get it because you don't have it!</i>”</p> <p>P8“...<i>you are talking to like a wall,</i> 62 <i>there's no reaction from him (doctor)</i>”.</p>
	<p>Communication Content</p> <p>Participants reported on the content of their discussion with</p>	<p>P1 “<i>He (doctor) said well, if I want the operation, he can do it for me, you</i> 59 <i>know. He explained the operation... First of all he</i> 60 <i>said he would not guarantee the pain will be gone, I will be cured you know and there is a</i> 61 <i>chances of me getting</i></p>

	<p>health professionals regarding their treatment options</p>	<p><i>paralysed...</i></p> <p>P4 “And why I accepted is because (name of doctor) did explain to me that 58 coming over to the psychological side will help me to at least like umm help me to try to manage 59 my pain so that I can have a normal life as possible.”</p> <p>P5“But if (doctors) explain the need then patient may be willing to attend such sessions lah yah... 46 yah it took me awhile but after they explain to me then I have a better understanding lah.”</p> <p>Example of a negative code</p> <p>P15”I requested to be referred to pain management clinic. But I was told by him, 92 no no no, that is only for people <i>who are...psychiatrically or mentally not stable</i> then 93 can go there.”</p>
	<p>Patients’ Treatment Expectations of Health Professionals</p> <p>Participants described their expectations of health professionals in treatment delivery.</p>	<p>P5 “...it took them a while to get the correct treatment or get the correct diagnosis...I was referred from 10 one department to another ...it’s very frustrating because you are the one who 11 is enduring the pain right and yet you do not know what you are suffering from. ...financially, emotionally everything it’s very taxing on the patient...”</p> <p>P8 “And that was the time 35 when I thought hey maybe I should be looking into other problems, like anxiety or whatever, 36 that’s the time I realised it but unfortunately my (name of hospital) guy never highlighted this to 37 me or he referred me.”</p> <p>P9 “The doctors 25 will actually have to tell the patient that a I mean refer the patient promptly lah. Otherwise,</p>

		<p><i>I'm</i> 26 <i>not too sure now, in the past it was not done so promptly for my case so I was quite upset at that</i> 27 <i>time lah.</i>"</p> <p>P11 <i>"Maybe you know umm I think I think</i> 159 <i>doctors would do a far better job if they realise that it is not just the physical body that we</i> 160 <i>are dealing with."</i></p> <p>P12 <i>"So until the first doctor find out</i> 148 <i>my problem ah...I very happy. I thank her, I cry you know. I cry of what? Not I am sad. Cry</i> 149 <i>at the moment I feel so touched, finally somebody tell me my problem ah."</i></p>
<p>Personal Attitudes and Beliefs</p>	<p>Beliefs about Treatment</p> <p>Participants discussed their beliefs about medical treatment for their pain condition</p>	<p>P7 <i>"innate fear that oh you know I am taking all these drugs is it</i> 35 <i>bad for me you know?"</i></p> <p>P8 <i>"</i>82 <i>But my personal philosophy is avoid medicine at all cost unless absolutely necessary."</i></p> <p>P10 <i>"the commitment to seek treatment</i> 28 <i>actually helps me reduce the pain and in getting myself treated"</i></p> <p>P11 <i>"I also have a part to play that I need to do all the</i> 9 <i>required exercises or the stretching"</i></p> <p>P12 <i>"I always said if I can control the pain I</i> 186 <i>don't want to take medicine lah. And trying to accept the pain, take less medicine."</i></p>
	<p>Expectations of Cure</p> <p>Participants discussed their expectations of cure for their pain condition</p>	<p>P3 <i>"will there</i> 11 <i>be any medical study or any other intervention you know beside operation that can help me</i> 12 <i>relieve my pain?"</i></p> <p>P6 <i>"...you get a bit more tired when you do the treatment the therapies and</i> 17 <i>you find a little bit of relieve from the pain. But then after a few more days the pain seems to</i> 18</p>

		<p><i>accumulate again. So whatever benefit you thought 19 you would see doesn't seem to be lasting then you need to go back for another session."</i></p> <p>P7 <i>"increasing levels of frustration 30 every time something would fail to... work as a complete cure. I think I was looking for a 31 complete cure... which I now realise, it's not easy. "</i></p> <p>P14 <i>"looking out for more options on how umm to prevent the pain from 54 aggravating further."</i></p>
	<p>Impact of Pain in their Lifestyle and their Relationship to Painful Activities</p> <p>Participants discussed the impact that pain had on their lifestyle.</p>	<p>P2 <i>"56 When the pain comes I always cannot focus, usually I feel like I'm a bit paralysed. Cannot do 57 anything then I might as well go and lie down. So whenever I lie down it's because the pain strikes. Then gradually because the pain always comes I always lie down"</i></p> <p>P4 <i>"I 35 felt that you know I cannot live a normal life... when the pain was in the initial stage 36 when it was very bad and at that time I was still working so it kind of like really interfere with my daily life yah."</i></p> <p>P9 <i>my daily lifestyle has to change to 20 accommodate to the pain which is not what I wanted to I 21 don't want to let pain take over my lifestyle."</i></p> <p>P11 <i>"if you are very negative then you you 93 probably focus more on all the pain. If you're very positive then you can probably psych yourself 94 to block out the pain."</i></p>
	<p>"So Why are we Paying Just to Talk?"</p> <p>Participants discussed their understanding of psychological treatment as a treatment for their pain condition.</p>	<p>P1 <i>"155 what can you do? You know? You can't really diagnose their medical condition... by just 157 talking and not really treating their conditions? No medications and what else? You 158 can't do anything...except just talking to 159 them."</i></p> <p>P3 <i>"at one stage I think I 40 was also a little skeptical. Without any a physical I mean operation that type of</i></p>

		<p><i>intervention how 41 do you put it? How are all these people going to help me to relieve my pain?"</i></p> <p>P6 <i>"I don't find much why am I taking time just to come here and 102 pay that kind of money and then what? I just hear only and people just listen then tell me this, 103 tell me that which is very standard and it's repetitive over the few sessions."</i></p> <p>P11 <i>"Maybe my first reaction is how come you refer me here? Are you saying that my pain is not 65 real? (laughter). You mean the pain is only in my head? But I do feel the pain!. I would probably feel angry and say... 74 What's wrong with you guys?...there are 75 signs and symptoms, I can't bend my hip, I can't bend my back you know? And and all these things 76 and how can you then you tell me that a that that's a no pain, no real pain yah?."</i></p> <p>Examples of Positive Codes</p> <p>P10 <i>"I understand what cognitive behaviour is about a 41 prior understanding of it I kind of was more acceptable, more receptive to this treatment and that 55 pre- knowledge is something that gave me that push to come, to accept the treatment."</i></p> <p>P12 <i>"I find that the person when they accept this CBT ah they got to be very open to every 254 treatment"</i></p>
	<p>Process of Seeking Treatment</p> <p>Participants' experiences in seeking treatment for their pain including psychological treatment were discussed.</p>	<p>P4 <i>"Experiences? I've been seeking treatment for almost more than 10 years. 3 At first I went to the orthopaedic department then later I was referred to the pain 4 management here."</i></p> <p>P9 <i>"The 7 Orthopaedic they just go in and they do everything, once nothing can be done then 8 that's it full stop. So I was having pain for quite a while, few years then Orthopaedic surgeon told 9 me there's nothing much he can do then he finally told</i></p>

		<p>me there's a pain management you can go 10 to and he referred me there."</p> <p><i>Examples of positive codes</i></p> <p>P3 "generally able to manage better...even when the pain is coming I know...how to deal with it...pain 13 management clinic, made me understand my pain and that is nothing so... life threatening 14 so scary you learn to manage your pain."</p> <p>P5 "So 31 once it was diagnosed and then they referred me to the correct department so I know that 32 my health had improved in a way it may not be 100% yet but at least umm I know where to seek 33 help or I know what kind of treatment they have to offer."</p> <p><i>Examples of positive codes for psychological treatment</i></p> <p>P2 "45 I think basically it can help me to understand myself and my pain problem better."</p> <p>P3 "so far the CBT the 24 program that I gone through...I'm more than satisfied... because...I feel I am under very good hands and most importantly my pain is 26 alleviated... I don't feel so much of discomfort... I already feel I can do more things with my life because I am able to 28 participate in more activities."</p> <p>P4 "Because I think it it does help... 34 especially I think pain is not just physical sometimes it's due to emotional"</p> <p>P7 "can I say how grateful I am for the psychotherapy. For this pain management program in (name of hospital) and I feel how it's a very enlightened approach to chronic pain</p>
--	--	--

		<p><i>and I'm glad I'm part of it."</i></p> <p>P10 <i>"Could I be imagining 113 such pain? Umm but having gone through sessions with the psychologist I realise that it is there 114 and I don't have to be afraid of it."</i></p>
<p>Practical and Social Factors</p>	<p>Social Support</p> <p>Participants discussed their preferences for support here</p>	<p>Example Codes for Family, Friends and Religious Support</p> <p>P7 <i>"The other way is religion alright where oh God takes care of 249 you, God we will pray for you. Yes yes that is one way of you know you feel somebody 250 supporting you, somebody taking care of you yes your stress levels go down and yes so that is 251 also one way."</i></p> <p>P9 <i>"I think sometimes my family members think that my tolerance of pain is very low... they always feel that 65 just a little of pain and you can't manage. Then how what, can you manage bigger things in life? I 66 was quite upset in the end, that closes the conversation...So even at home when it's on pain I just keep quiet because you know the 68 response from them is something negative. So there's no point in talking and complaining about it."</i></p> <p>P14 <i>"In terms of success we actually have 25 support from friends."</i></p> <p>Example Codes for Government Support</p> <p>P4 <i>"107 I suppose if the government can subsidy (laughter). I think that would be good. Because till now I 108 think certain treatments or certain medications are not being subsidised by the government."</i></p> <p>P5 <i>"Maybe the government can 129 give grant, subsidies, yah I think if</i></p>

		<p>they can offer more subsidy it will be better still then I 130 think if the price is affordable right at least more patient I think willing to open up or come.”</p> <p>Example Codes for Support Group</p> <p>P6 “Because you need 203 motivation, you need encouragement...how 204 about group therapy?”</p> <p>P7 “what I think would have been helpful a pain support group. Have you all thought of doing that? 83 You know there are so many support groups...Why 84 not have a pain management (group)?”</p> <p>P9 “157 I think maybe a focus group sharing would be good. I mean it’s like a all the patients who are 158 actually going through the same thing actually come together and share with each other. 159 Because how I manage it and how other people manage it can be quite different. And maybe you 160 can learn from how others do. Because the thing is you and I the patients are all having the same 161 problems so umm how they manage it umm can be very different. So we can learn from each...”</p> <p>P 14 “with this success stories, this will actually help the patients 79 to understand better also they are also willing to umm, they are actually open to have the 80 willingness , the willingness to open up themselves to work further with the health professionals.”</p>
	<p>Practical Barriers</p> <p>Current practical barriers to psychological treatment uptake were discussed.</p>	<p>Example Codes for Cost</p> <p>P1 “probably this is one of the reason why people... also don’t want to 223 come to see (the psychologist)...Even though they know, they still don’t want to</p>

		<p>come, 224 because it's like I said the price (yes)... First of all, they got to 225 come to see (name of doctor) , then after that physio then on top of that they have to 226 come and see (the psychologist) and they have to pay some more. If only thing they can deduct 227 through ...medisave...subsidised maybe? ...by a 228 certain percentage. They come out cash another certain percentage of it"</p> <p>P6 "You know tangible benefits and 100 you need to pay for the session and it's not cheap I understand."</p> <p>P7 "it's 197 cheap yet. Will I pay \$80 for it? Will I pay \$100-\$200 per session, no I will not. Unfortunately, the 198 frame of mind is that ok I need to pay for my medicines, I need to pay to see the doctor yes but 199 will I pay market rates for psychotherapy generally for chronic pain I would not ok."</p> <p>Example Codes for Time</p> <p>P4 "24 I think for me because I am retired so not much of a problem but I think for working folk to 25 have to come here regularly could be quite a problem to take leave to come."</p> <p>P12 "But another thing I would say 180 you need to have time. If...now I am a working lady I think it's quite hard."</p> <p>Example Codes for Access to Appointments and Resources</p> <p>P3 "so far I'm able to access the whole 90 department pain management clinic. I'm able to access most of the staff very easily....91 personally I don't think there's any hinderance... I find the admin staff 92 are also very helpful if I want to reach the psychologist or want to reach the</p>
--	--	---

		<p><i>doctor, I'm able 93 to get them not during my appointment time, even other time."</i></p> <p>Example of a negative code</p> <p>P6 <i>"People like us already 229 facing a lot of pain I don't wait for the schedule ah sorry I cannot change appointment. The 230 doctor is not in, the therapist not in, (the psychologist) it's fully booked so can we have something that is 231 easier access."</i></p>
	<p>Environmental Facilitator and Promotional Material</p> <p>A discussion of possible ways to improve psychological treatment uptake</p>	<p>Example Codes for Education</p> <p>P4 <i>"82 I suppose it's education...if they know...the psychological and physical is related 83 then I think they are more willing to try...educating them to what are the advantages of going for this kind of treatment..."</i></p> <p>P10 <i>"84 I think at some point, the right education will help the patient and a certain level of 85 cognitive understanding umm."</i></p> <p>Example Codes for Public Awareness</p> <p>P9 <i>"146 I think not everybody know about this service that is available. So maybe generally a 147 community outreach...to actually tell people that there is this facility 148 here."</i></p> <p>P15 <i>"It also depends on how health promotion board want to promote this 343 psychological treatment for pain management. It depends on the team 344 who intend to promote such service, and depending on 345 the way they want to structure it and for whom and what audience."</i></p> <p>Example Codes for Published Information</p> <p>P8 <i>"More literature maybe. For people</i></p>

		<p>142 <i>who are waiting sometimes we can be waiting for 1-2 hours...At least for 143 people like me I would like to have more literature."</i></p> <p>P13 <i>"we can design flyers...banners so we can reach out to the patients, the visiting 68 the hospital."</i></p> <p>P14 <i>"more brochures and handouts on the avenues to reach out for help"</i></p> <p>Example Codes for Utilising Media and Technological Platforms</p> <p>P4 <i>"112 I think besides the current treatment maybe can have some talks so that patient can 113 understand better you know, how to manage pain...Talks or seminars would be 114 good."</i></p> <p>P5 <i>"107 Maybe ok like radio program...something like Dr OZ..a sharing of the medical problem then the solution. Maybe Singapore can also have like a 109 program to share with the viewers or the public so at least they know ok if I have this 110 condition I can contact this one. Have a reality medical program...on the radio the 111 doctor or nursing profession can share their knowledge also."</i></p> <p>P10 <i>"51 there are actually quite a lot of information umm general information about cognitive behavioural 52 therapy and I think there was one website where it's quite comprehensive...I think that website was very helpful and it spells out a 54 lot of things umm and after reading it I thought it would be helpful for me."</i></p> <p>P11 <i>"So maybe audio visual umm it would actually help but of course... 142 involves also more resources yah... 144 Like you know making use of the media, making use of the things like youtube yah to 145 inform</i></p>
--	--	--

		<p><i>and also...so that they can access on their smart phones”</i></p> <p>P15 <i>“nowadays everything 266 is on the internet and everybody is internet savvy...you can get lots of 267 information and data.”</i></p>
--	--	---

Appendix C. Chapter 8: Coding Manual for Health Professionals' Codes

Themes	Subtheme Labels and Definitions	Example of Codes (by participant and line number)
System Barriers	<p>Challenges to get a group of people who are interested in chronic pain management</p> <p>Only a small pool of health professionals including psychologists are interested in chronic pain management, there are barriers in recruitment and training with many health professionals having misconceptions about chronic pain treatment.</p>	<p>P7 <i>“within the group of psychologists that is available there 31 is very very few of them who are interested in chronic pain and managing patients with chronic 32 pain.”</i></p> <p>P11 <i>“we need to have umm 100 psychologists who are interested in this area to work and to be here and to have appointment 101 slots.”</i></p> <p>P13 <i>“I’ve contacted 87 hospitals and they’ve got psychologists who specialise in pain but when you actually see what 88 they do I wouldn’t send them there.”</i></p>
	<p>“Top down approach, takes a long time to change things.”</p> <p>Healthcare system perceived to be hierarchical with many layers of approval needed for changes to be implemented.</p>	<p>P4 <i>“in terms of umm medical support right it’s not so good and hospital is 40 not very supportive in terms of setting up of a pain management service or centre 41 ...because they say umm that is not really very important..”</i></p> <p>P7 <i>“our 63 previous proposal to start a CBT program was a to send a team for a CBT program training was 64 unfortunately rejected by the hospital in view that they felt that there was more pressing areas 65 where they want to</i></p>

		<p>send people for HMDP training. But we are still trying, we haven't given up</p> <p>66 hopefully we are able to do something in the future...current healthcare system in Singapore it's a very hierarchical very sort of 299 a very top down approach..."</p> <p>P8 "I think 49 locally we are not doing that as much as some of the overseas setting. I think the trend is still very 50 much into elimination kind of process."</p> <p>P13 "the issue you are going to have is in Singapore it's 151 not a criticism it's just a fact that because of the way the healthcare system is set up here it's 152 even in the hospitals it's private healthcare and...that really is going 154 to always reduce the umm likelihood of proper and correct inter-referral I think."</p>
	<p>Lack of Resources</p> <p>Lack of funding to subsidise the high cost of general treatment and psychological treatment for chronic pain.</p>	<p>P5 "in Singapore I think is the cost of it, because we tried to organise you know 82 the CBT but in the end right when the costing come out few hundred dollars or up to a thousand 83 for group therapy you know per person. In Singapore it's not really very possible...84 in the patients that I have broached the subject to,</p>

		<p><i>most of them have said that they are either not free or you know they find that the cost is too hefty for them to bear.”</i></p> <p>P7 <i>“In terms 252 of healthcare funding I’m a firm believer that more can be done. That the current levels of 253 funding are not sufficient and we have a significant number of patients who cannot afford their 254 treatments because of funding issues ...I mean it applies to psychotherapy but it also applies to medication costs or even acupuncture.”</i></p> <p>P7 <i>“there is also a 36 huge shortage of funding, and therefore as a physician I am not able to offer this to patients 37 because some of the cost is prohibitive. And as currently the ministry has not approved any form 38 of funding or even medisave for the use of procedures... those are the areas that...currently can be improved upon.”</i></p> <p>P15 <i>“at the moment they are allowing 227 medisave to be deducted for chronic cases like diabetes and all that right? So, so I think like umm 228 Ministry of Health needs to acknowledge that pain is as chronic as diabetes as chronic kidney disease...If that happens then 231 people will</i></p>
--	--	---

		<p><i>come forward (for treatment.”</i></p>
	<p>Lack of Psychologists</p>	<p>P1 <i>“216 Singapore actually is short of psychologist as 221 far as I understand it takes a very long time to get enough psychologist ...I think NUS (National University of Singapore) is 222 trying to do clinical psychology now right I heard some the applicants is some phenomenal 223 number and they only pick less than ten people or something like that. So the training is going to 224 be difficult before we hit the critical mass of psychologist.”</i></p> <p>P3 <i>“I think that in Singapore umm...we have resources available for patient 18 with chronic pain but it may not be well equipped. We may not have good enough 19 programs umm...to facilitate.”</i></p> <p>P4 <i>“We do 14 have a psychologist who can help us (inaudible) umm I think they are not really trained you know 15 in pain management. They do have some experience lah but they are not very well trained in 16 terms of chronic pain management.”</i></p> <p>P7 <i>“In terms of psychology there is huge shortage of psychologists in Singapore. I 28 understand from my</i></p>

		<p><i>psychiatry and psychology colleagues there is a general lack of psychologists 29 in Singapore. Umm am not sure of the exact number but my experience is more than half of the 30 psychologists are not Singaporeans. This is in huge contrast to my experience overseas where there is a large pool of well trained 33 psychologists who both have an interest and very adapt at managing patients with chronic pain 34 both in the public and private sector.”</i></p> <p>Example codes on how to manage the issue of a lack of psychologists</p> <p>P12 <i>“hospital should have a core group of trainers really. I mean not everybody 103 has to be so specialised really, it can be different levels of expertise and skills involved because 104 not every patient needs to see a well- trained psychologist to go through CBT that’s my take on 105 that.”</i></p> <p>P15 <i>“The nurses are usually like the ones that 290 are not really known in a sense and they do a lot of education... if they are allowed to do 291 all this education, that takes the load off the therapist and the therapist can do their thing.”</i></p>
	<p>Lacking a</p>	<p>P1 <i>“if you come from a 153 centre, that is they</i></p>

	<p>Biopsychosocial approach</p> <p>Healthcare approach towards chronic pain treatment follows more of biomedical and unimodal approach than a multidisciplinary one.</p>	<p><i>train in a centre that is very procedural base. Then I think that you are 154 always looking for other procedures to do”</i></p> <p>P2 <i>“I will do the biomedical 17 model whereby if there is something that can be eradicated we will eradicate it either through 18 interventions or surgeries.”</i></p> <p>P5 <i>“I think most of the physicians treating pain still treat it as a one dimensional sort of disease. 64 And they don’t realise that the patient that comes to see you for pain problems actually have a 65 multitude of problems and that can also be psychosocial....68 with the increasing clinical workload and administrative of all the doctors it is very hard for a physician to 69 actually explore the psychosocial make-up of the patient.”</i></p> <p>P7 <i>“...basically the teaching in medical school is very much 13 still a biological model of pain. So, I think in all these various aspects these are sort of barriers 14 to patients who have chronic pain from a treatment that they can possibly seek.”</i></p> <p>P8 <i>“There is still this emphasis on the biomedical side but I think across the board I 53 think even physios</i></p>
--	---	---

		<p>who started working in the pain setting...they still kind of</p> <p>54 hang on to the biomedical side of it.”</p> <p>P14 “for the chronic pain treatment...I understand in our hospital we have a 19 variety of options for...pain relieve. Umm...I guess it’s more on the 20 medications la, more on medications and some procedures.”</p> <p>Example codes specific to health professionals not referring to psychologists</p> <p>P1 “I belong to the old MBBS structure where 189 the amount of psychology we are exposed is very minimal... Most of the psychology I picked up later when I was doing pain 191 exam. So in the undergraduate years you get very little psychology so you don’t actually know 192 what the psychologist actually do. And a so, unless they are blatantly quite mad to you most of 193 the time we don’t think of referring to psychology, yah.”</p> <p>P2 “They are not exposed to the concepts of CBT and they are not trained in 74 multidisciplinary aspects of pain treatment. They don’t know. If they don’t know they can’t 75 appreciate the need for it.”</p>
--	--	--

		<p>P6 <i>“certain physicians...if 67 they have seen enough of certain group of patients who are exposed to CBT but didn't 68 seem to help them they may form an opinion of their own to think that this is 69 not going to help. It's a waste of time.”</i></p> <p>P7 <i>“I have not seen an 141 orthopaedic surgeon refer to a psychologist directly and again that's probably they don't 142 because they don't know much about psychotherapy or what psychologists do.”</i></p> <p>P10 <i>“they are 75 not so sure what the psychologists are doing umm that's one thing, second they don't recognise 76 that the patient require it and... I think that's about it.”</i></p> <p>Example codes of how to increase referrals to psychologists</p> <p>P3 <i>“101 What I think is helpful to facilitate to endorse to promote is actually to help other health 102 care services understand where psychology comes in”</i></p> <p>P5 <i>“a greater awareness should be made...you know...of the fact that psychologist can 98 help in such conditions because you know not all patients with chronic pain sees the pain 99 specialists... the hospital</i></p>
--	--	---

		<p><i>administrators must buy in to the idea first that having such a program 110 will then reduce the burden of patients on the doctors.”</i></p> <p>P7 <i>“I think all the other healthcare professionals from my nurses to 180 my junior doctors, all of them will benefit from having a basic knowledge of psychology in 181 chronic pain.”</i></p> <p>P10 <i>“85 Awareness, building up the awareness of what psychologists can do I think that’s a big thing.”</i></p>
<p>Core beliefs and management of chronic pain</p>		<p>P7 <i>“also it makes it 15 difficult for healthcare professionals to work in that area coz you sometimes have to deal with a 16 lot of umm mistaken beliefs from both patients and fellow healthcare professionals 17 about how chronic pain is viewed and how it should be managed.”</i></p> <p>P7 <i>“157 healthcare professionals involved in the care of the patients would do well to learn about 158 the various psychological constructs or problems that may manifest in a 159 chronic pain patient and therefore be able to identify. And then follow up with a referral for 160 treatment.”</i></p> <p>P8 <i>“I think when you talk about psychology, people just sit down and 202 just talk lah that’s the usual idea so I think the outcome...needs to be a bit 203 more concrete like physios, people like some of the doctors they like concrete stuff.”</i></p> <p>P12 <i>“doctors I think there may be ego-ed part of not wanting to 50 let go that they can still do something for the patient.”</i></p> <p>P13 <i>“it’s an education process with the practitioners. I think some practitioners have 69 not kept up to date with pain exploration and pain research.”</i></p>
		<p>P1 <i>“they are very fixated</i></p>

	<p>Health professionals' perceptions of patients' perception of pain</p> <p>General perceptions of health professionals on patients' expectations of pain treatment as well as perceptions of psychological treatment for pain.</p>	<p><i>on what they want to think or 57 what they want to believe. They pick and choose a treatment that they want. They are not very 58 open...</i></p> <p>P3 <i>"when they come in they would 5 would not usually see the psychological issue. They are usually in for treatment they want a 6 cure they are hoping we can do something to help them take away the pain."</i></p> <p>P9 <i>"If all of them are at the maybe pre-contemplation stage then it will be a hard 144 group to facilitate..."</i></p> <p>P15 <i>"the challenging ones are maybe the very chronic ones, they are just into that 73 role and they don't seem to be able to get out of the role. And no matter what you do they are 74 still there even though you've given them a little bit of a reprieve sometimes, they get 75 some short periods of maybe pain levels that are better but after that they don't seem to go on 76...and they get stuck then."</i></p> <p>Example codes of health professionals' views about patients' views about psychological treatment</p> <p>P1 <i>"if you bring up too early 144 people think</i></p>
--	--	--

		<p><i>that you think there is no other treatment for them and they think 145 that you think that they are a bit crazy or mad so that actually breaks up the trust and rapport. 146 So I might actually bringing up at the third or fourth (visit). Surprisingly some of them seems to be ok”</i></p> <p>P3 <i>“I would recommend the CBT...treatment to patient if I think that patient has got 62 the ability to appreciate the concepts, who are willing to step out of where they are of 63 their beliefs to learn something new and be flexible about the way they think about 64 things.”</i></p> <p>P4 <i>“psychological therapy is also not 146 you know umm...so attractive because like most people don’t like to see a psychologist or 147 when they hear the psychological therapy then they are a bit you know umm concerned why I 148 am seeing?”</i></p> <p>P5 <i>“CBT...in the local 36 context however, I find that it’s extremely challenging you know to get patients engaged to the 37 idea that you know they should undergo a certain program to help them modify their beliefs and 38 thoughts about pain.”</i></p> <p>P6 <i>“most of these patients</i></p>
--	--	---

		<p>82 that I see right, most of them they feel there is a stigma...are you referring that I 83 am depressed, I'm xiao (mad) you know? So the moment we talk about 84 referring to a psychologist or a psychiatrist, from that instance they tend to be a little 85 bit worried..."</p> <p>P7 "I think 162 psychotherapy in my own experience is something that works when a patient has an open mind 163 to it. If they from the start they have a mistaken notion about it even if they go they usually just 164 go because I told them to and after one visit they will come back and tell me it don't work when 165 I've told them you need to give it a chance. I actually try to teach, tell them why its helpful and how 167 you can benefit but again if my patients are flatly rejecting I find that it is pointless to force 168 them to go because it's just a waste of everybody's time and resources."</p> <p>P8 "I'm quite open to referring cases I think I think the reason why I 120 might not suggest is half the time I get vibes from the patients that they are not ready yet."</p> <p>P9 "before you get them to self- manage they have to first be a 40</p>
--	--	---

		<p><i>receptive of the fact that they might need to change the way how they usually do things their 41 mindset</i></p> <p>P11 <i>"I think if it's desperately long it's 103 like I've done this I'm like you know I'm so good at this now I don't think they help, I don't think</i></p> <p>104 <i>it's a psychological issue. It's a real pain they don't see it."</i></p> <p>P15 <i>"sometimes, even if we 78 ourselves try to push that psychological point of view, it's not received so sometimes if they don't 79 receive it then it can be very difficult to go on...some people just don't, if they don't I can't 81 do it, I can't really do anything."</i></p>
<p>Engaging patients in treatment</p>	<p>Close and therapeutic relationship needed</p> <p>Type of Patient-Health professional relationship needed to facilitate psychological treatment uptake</p>	<p>P1 <i>"I think that over time 76 you do build rapport with them they find that umm that you are easy to talk to and 77...eventually it's easier for you to sell the idea of certain things to them yah."</i></p> <p>P6 <i>"besides pharmacology, to be successful in treating 24 this group you definitely need the other component in having a very close and therapeutic 25 relationship."</i></p> <p>P9 <i>"So eventually it's also a bit more of the therapeutic 65</i></p>

		<p><i>relationship and the therapeutic communication. So sometimes when you have a bit more rapport 66 they are a bit more willing to reflect on what you reflect back to them as well yah."</i></p> <p>Example of a negative code <i>"I can also see that 108 sometimes even if you are willing and you do get them to see a psychologist ,109 sometimes it's the interaction between the psychologist and the patient and that can be another 110 road block."</i></p>
	<p>Educate patients on the benefits of psychological treatment</p> <p>Patients need to have the knowledge and understanding of the applicability of psychological treatment in treating their pain.</p>	<p>P4 <i>"education is one I mean anything 94 that you would like people to know and support right? First of all you need to tell them, educate 95 them what is it? How it works and what is the benefit."</i></p> <p>P6 <i>"we need to really educate them, to tell them that pain sometimes tend to have 86 association with a bit of depression, it's a bi-product of relationship so when you treat pain you 87 treat depression... you have to educate the 96 healthcare and staff from the physician point of view you know. Educate mainly on pain 97 management... 98 maybe even to the public."</i></p> <p>P10 <i>"I think a lot of</i></p>

		<p><i>education in 48...how they have to change the behaviour when the pain comes in, how they 49 have to cope with it umm so the receptivity on that is very important and how they change their 50 lifestyle..."</i></p>
	<p>Importance of involving the family</p> <p>Family support can enhance patients' engagement in treatment</p>	<p>P4 <i>"for chronic pain you need to communicate 63 with family members, you need to communicate with healthcare workers... 64... and then also need to make sure the relative understand the patient. 65 So it's very important you know a better way of communicating their problem with their loved 66 ones, with healthcare workers."</i></p> <p>P6 <i>"I feel that tapping 154 on the family members, the carers, is the way to go to help reach out to this group... 155 Because they always have formed a certain opinion of how to do this do that. They have 156 a certain fixed idea of their own. A little bit difficult unless you are somebody familiar and you 157 are the caregiver then they may listen."</i></p> <p>P15 <i>"263 To look at the environment and how that is affecting the person is always very important. 264 Support lah basically is there any support? Then sometimes you don't engage the person's carer</i></p>

		<p>265 or people that they live with then people don't understand umm...how about...employers? Yah 266 employers, those people that they go back to work, that they go back to work with umm, their 267 co-workers. Their significant other."</p>
<p>Creating awareness for chronic pain management.</p>	<p>Endorsement from health professionals</p> <p>Health professionals need to understand the benefits of psychological treatment be able to explain to patients the need for psychological treatment and be willing to refer patients for it.</p>	<p>P3 "it would be 157 nice if we can collect data before and after treatment and that, that kind of reflects how 158 successful the program is."</p> <p>P4 "see whether can bring 102 in you know experienced people from overseas umm...they have already conducted CBT 103 program they already have their data to actually support or to actually show ...104 therapy is effective ...or do have benefit so I think that will able to help."</p> <p>P11 "Perhaps a time for all of us to get in for observation of how this (CBT) is 137 done. I think that will help us a lot."</p> <p>P12 "74 Outcome at least outcome of pain reduction itself, a perception of change by the physician not 75 just the patient, utilisation of resources for treatment of pain that means there must be 76 some demonstration of health economic benefits I think that is</p>

		<p><i>important also.”</i></p> <p>P15 “You need to establish that first...220 umm...people need to know that you have this umm...people would want to know what is 221 your success rate. So you would have had to have done something already before to show that 222 ok this works, come do it.</p>
	<p>Endorsement through patient experience</p> <p>Success stories from other patients who have experienced psychological treatment are important to facilitate psychological treatment uptake</p>	<p>P3 “it’s very helpful if patients can communicate about the 156 success through word of mouth.”</p> <p>P4 “people will have to see the benefits so maybe we may have to come up 98 with a group, to pilot the group and see what is the result and then you can use the result to 99 convince people...let’s say we have some good benefits or good results 100 then patient can be the testimony of the CBT program because they actually benefit from the 101 program.”</p> <p>P8 “all these little (patient) stories...83 they become a little database where you can use it on other patients and the other patients 84 actually learn from it...”</p>
	<p>Use of media and technology</p> <p>Ways to utilise media and technology to</p>	<p>P3 “regular e-mail blast just to share 145 about some of the ways you can manage, just some basic pointers so that</p>

	<p>enhance patients' uptake of psychological treatment and health professionals' referring patients for psychological treatment</p>	<p><i>along the way 146 patients might feel connected as well and...think that would be effective to connect to 147 patient and it doesn't take too much time of the therapist or the healthcare worker."</i></p> <p>P6 <i>"...online might be 116 possible. Facebook, things like that to help sell the idea that pain management plus psychological 117 treatment is actually very important not just medicine alone... On line would be affordable coz everybody use iphone something smart phone or 130 internet things like that."</i></p> <p>P7 <i>"I think that it will be helpful for patients who have 153 chronic pain to maybe have access to have a patient information leaflet just broadly speaking 154 about what psychotherapy is and what are the different types of psychotherapy available that 155 can help chronic pain patients and there's a huge number and variety of psychotherapy 156 techniques."</i></p> <p>P12 <i>"54 I think if the program can be made to be more easily available you know for example 55 having it online there is sort of online sort of a service where by you know patients can do it at</i></p>
--	---	--

		<p>56 home...it should be portable, it should be well 68 structured it shouldn't be too complicated yah. It must be definitely interactive...and 69 of course it would be great if it's very much outcome based."</p>
--	--	--

YOU ARE INVITED

We are currently conducting a survey on pain treatment in Singapore and would like your views on some issues. This survey would take approximately 20-30 minutes to complete. Your responses will remain anonymous and confidential.

Dear participant,

Thank you for taking time to complete this survey. A total of 200 participants who are Singapore citizens/permanent residents, between 21-65 years old and have experienced pain for more than 3 months (occasional pain or continuous pain) are being recruited for this survey.

I am a 2nd year PhD student at King's College London and also a health professional at the pain management clinic at Tan Tock Seng Hospital [*Contact details: Pain Management Clinic, Tan Tock Seng Hospital, 11 Jalan Tan Tock Seng, Singapore 308433, Tel: 6357 8352 (0), e-mail: su_yin_yang@ttsh.com.sg*]

You are being asked to complete a short survey on treatment for chronic pain in Singapore and a set of pain related measures. There are no right or wrong answers.

There are no potential risks or side effects related to your participation in this study. Your participation will help us as we research ways to create more effective treatments for chronic pain.

If you agree to participate in this study, please complete the full survey.

The online survey can be assessed at the following link:

<http://survey.iop.kcl.ac.uk/TakeSurvey.aspx?SurveyID=72KK889K>

Or through the TTSH pain management clinic website at:

<http://www.ttsh.com.sg/PMC>

Click on the red box indicating **Chronic Pain in Singapore Survey** to complete the survey.

Your input is highly regarded and deeply appreciated as it will help us develop a new treatment for chronic pain. Please contact me should you have any queries.

Yours sincerely,

Su-Yin

Participant No:

Pain Management Clinic (PMC)

Tan Tock Seng Hospital

Today's date: Day: _____ Month: _____ Year: _____

Thank you for giving consent to take part in this study. Your participation will inform the second part of our study.

You will be required to complete a short survey and a set of pain-related and Acceptance and Commitment Therapy (ACT) based measures.

Please read each question carefully, and do not spend too much time on any one question.

The questions are not meant to have right or wrong answers as such. Your answers will depend upon your circumstances. Simply reflect your experiences as openly and directly as you can.

The information that you provide in this form is confidential and anonymous. Your responses are kept in a secure location, separate to your medical notes and will not be seen by anyone apart from the principal investigator (PI).

You have the right to discontinue your participation or withdraw your individual information at any point.

If you have any difficulty completing these questionnaires, or any further questions, please ask the principal investigator and she will be happy to help you.

INSTRUCTIONS

First, we would like to know a little about you. Please respond to each of the following questions as they apply to you.

1. Are you a Singapore citizen/ permanent resident?
 YES NO
2. Have you experienced pain for more than 3 months?
 YES NO
3. How long have you been suffering with chronic pain (mths)? (chronic pain is defined as pain lasting more than 3 month)
4. Are you between 21-65 years of age?
 YES NO

Section 1

Please select/twrite in the appropriate answer to the following questions.

5. I am
 Male Female
6. How old are you? (The value must be between 21 and 65 inclusive)
7. What is your race?
 Chinese
 Malay
 Indian
 Eurasian
 Others
8. Where is the main site of your pain?
 Head, face and mouth
 Neck region
 Upper shoulder and upper limbs
 Chest region
 Abdominal region
 Lower back, lumbar spine, sacrum and coccyx
 Pelvic region
 Legs or feet

Anal and genital region

9. Have you sought treatment for your pain problem?

YES NO

10. Who did you go to see to treat your pain?

(e.g. GP, Traditional Chinese Medicine/other traditional treatment, physiotherapist, osteopath, self-medicate, etc). Specify only treatments that you use most often.

11. Are you currently taking medication for your pain?

YES NO

12. Are you currently seeing a pain specialist for treatment?

YES NO

13. Have you previously received Cognitive Behavioural Therapy (CBT) treatment for your pain?

YES NO I do not know what this is

14. How were you invited to take part in this study?

- By a healthcare professional
- Through the Tan Tock Seng Hospital Website
- Through the Pain Association of Singapore Website
- Through a GP/Specialist clinic
- Through a friend/relative
- Through a support group

15. What is your marital status?

Married Divorced Single Widowed Other

16. Do you live _____

- Alone
- With husband/wife and children
- With child/children only
- With parents
- With friend/flatmates
- With a partner

17. What is your highest level of education?

- Postgraduate
- GCE "O" Levels
- Degree
- Less than Secondary 4
- Diploma
- Primary education

GCE "A" Levels

18. What is/was your main occupation?

19. What is your current work status?

Full time work

Part-time work

Voluntary work

Home duties

Retired

Student

Not working due to pain

Working part time due to pain

Unemployed due to other reasons

Re-training

20. If working, how much time have you taken off work due to pain in the last year? (Days of medical leave)

Survey

Cognitive Behavioural Therapy (CBT) is an established form of treatment for chronic pain around the world. It is based on teaching people skills for managing pain and changing ways in which people respond to pain.

1. Which of the following would you rate as important factors that will PREVENT or DISCOURAGE you from attending a CBT based treatment? Please rate the importance of each item by circling a number on a scale of 0 to 10 where “0” represents “not at all important” and 10 represents “extremely important”.

a) High cost of treatment

Not at all important	0	1	2	3	4	5	6	7	8	9	10	Extremely important
----------------------	---	---	---	---	---	---	---	---	---	---	----	---------------------

b) Lack of information about CBT

Not at all important	0	1	2	3	4	5	6	7	8	9	10	Extremely important
----------------------	---	---	---	---	---	---	---	---	---	---	----	---------------------

c) Calling the treatment psychological

Not at all important	0	1	2	3	4	5	6	7	8	9	10	Extremely important
----------------------	---	---	---	---	---	---	---	---	---	---	----	---------------------

d) Stigma (Fear of others knowing I am in CBT treatment)

Not at all important	0	1	2	3	4	5	6	7	8	9	10	Extremely important
----------------------	---	---	---	---	---	---	---	---	---	---	----	---------------------

e) Poor support from family and/or friends for treatment

Not at all important	0	1	2	3	4	5	6	7	8	9	10	Extremely important
----------------------	---	---	---	---	---	---	---	---	---	---	----	---------------------

f) Treatment based in hospital

Not at all important	0	1	2	3	4	5	6	7	8	9	10	Extremely important
----------------------	---	---	---	---	---	---	---	---	---	---	----	---------------------

g) Lack of explanation by health professional referring me for CBT treatment

Not at all important	0	1	2	3	4	5	6	7	8	9	10	Extremely important
----------------------	---	---	---	---	---	---	---	---	---	---	----	---------------------

h) Poor relationship with the healthcare professional recommending treatment

Not at all important	0	1	2	3	4	5	6	7	8	9	10	Extremely important
----------------------	---	---	---	---	---	---	---	---	---	---	----	---------------------

2. Which of the following would you rate as important factors that will help or encourage you to attend a CBT based treatment? Please rate the importance of each item by circling a number on a scale of 0 to 10 where “0” represents “not at all important” and 10 represents “extremely important”.

a) Low cost of treatment

Not at all important	0	1	2	3	4	5	6	7	8	9	10	Extremely important
----------------------	---	---	---	---	---	---	---	---	---	---	----	---------------------

b) Understanding of CBT treatment

Not at all important	0	1	2	3	4	5	6	7	8	9	10	Extremely important
----------------------	---	---	---	---	---	---	---	---	---	---	----	---------------------

c) Proof that treatment will help me or that treatment is effective

Not at all important	0	1	2	3	4	5	6	7	8	9	10	Extremely important
----------------------	---	---	---	---	---	---	---	---	---	---	----	---------------------

d) Easy access to treatment (eg. through internet, mobile applications)

Not at all important	0	1	2	3	4	5	6	7	8	9	10	Extremely important
----------------------	---	---	---	---	---	---	---	---	---	---	----	---------------------

e) Good support from family or friends for treatment

Not at all important	0	1	2	3	4	5	6	7	8	9	10	Extremely important
----------------------	---	---	---	---	---	---	---	---	---	---	----	---------------------

f) Treatment based in hospital

Not at all important	0	1	2	3	4	5	6	7	8	9	10	Extremely important
----------------------	---	---	---	---	---	---	---	---	---	---	----	---------------------

g) Trust in healthcare professional’s recommendation for CBT treatment

Not at all important	0	1	2	3	4	5	6	7	8	9	10	Extremely important
----------------------	---	---	---	---	---	---	---	---	---	---	----	---------------------

h) Good relationship with healthcare professional delivering treatment

Not at all important	0	1	2	3	4	5	6	7	8	9	10	Extremely important
----------------------	---	---	---	---	---	---	---	---	---	---	----	---------------------

Treatment Delivery Formats

We are interested in your views about the treatment delivery format of a pain management service. The questions in this section ask for your opinions about the design of a potential pain management service.

Which of the following would you prefer for a pain management service?

1. Treatment delivered (you may select more than 1 option)

- In person (face-to-face) individually
- In person in a group
- Self-help book/resource
- By telephone
- Online (web-based interface)
- Interactive video based method (Skype or a similar program)
- A combination of the above choices

2. Please rank your top 3 preferences from the treatment options you have selected above by ticking the appropriate box.

	1	2	3
In person (face-to-face) individually	<input type="checkbox"/>	<input type="checkbox"/>	<input type="checkbox"/>
In person in a group	<input type="checkbox"/>	<input type="checkbox"/>	<input type="checkbox"/>
Self-help book/resource	<input type="checkbox"/>	<input type="checkbox"/>	<input type="checkbox"/>
By telephone	<input type="checkbox"/>	<input type="checkbox"/>	<input type="checkbox"/>

- Online (web-based interface)
- Interactive video based method
(Skype or similar program)
- A combination of the above choices

3. If you prefer a combination of treatment choices, please specify your combination of choice

4. What is your ideal duration per treatment session?

- 30mins 45mins 60mins 90mins 2hr 4hr (half day)
- 7hr (full day)

5. Number of treatment sessions per week

- 1/week 2/week 3/week 4/week Daily

6. Total number of treatment sessions

- <4 4 5 6 7 8 9 10 >10

7. How should we publicise this treatment? (select all that apply)

- Information leaflet/Brochures
- Hospital/clinic wide advertisements
- Public seminars/forums
- Inter-hospital department advertisement
- E-mail notification
- A website

8a) The current charge per 1hr treatment session is approximately **\$ 90** (private treatment) and **\$ 30** (subsidised treatment). Regardless of whether you would pay this specified amount, what cost do you feel most people would be willing to pay?

b) What would be the lowest amount you would pay for this treatment?

Section 2

Pain Scale

Please indicate on the scale below by ticking the box corresponding to the number between 0 and 10 that best describes your pain.

1. How intense is your pain *right now*?

“0” “10”
No pain Worst possible pain

0	1	2	3	4	5	6	7	8	9	10
<input type="checkbox"/>	<input type="checkbox"/>	<input type="checkbox"/>	<input type="checkbox"/>	<input type="checkbox"/>	<input type="checkbox"/>	<input type="checkbox"/>	<input type="checkbox"/>	<input type="checkbox"/>	<input type="checkbox"/>	<input type="checkbox"/>

2. How intense was your pain *on average last week*?

“0” “10”
No pain Worst possible pain

0	1	2	3	4	5	6	7	8	9	10
<input type="checkbox"/>	<input type="checkbox"/>	<input type="checkbox"/>	<input type="checkbox"/>	<input type="checkbox"/>	<input type="checkbox"/>	<input type="checkbox"/>	<input type="checkbox"/>	<input type="checkbox"/>	<input type="checkbox"/>	<input type="checkbox"/>

3. How distressing is your pain *right now*?

“0” “10”
Not at all distressing Worst distress possible

0	1	2	3	4	5	6	7	8	9	10
<input type="checkbox"/>	<input type="checkbox"/>	<input type="checkbox"/>	<input type="checkbox"/>	<input type="checkbox"/>	<input type="checkbox"/>	<input type="checkbox"/>	<input type="checkbox"/>	<input type="checkbox"/>	<input type="checkbox"/>	<input type="checkbox"/>

4. How distressing was your pain *on average last week*?

“0” “10”
Not at all distressing Worst distress possible

0	1	2	3	4	5	6	7	8	9	10
<input type="checkbox"/>	<input type="checkbox"/>	<input type="checkbox"/>	<input type="checkbox"/>	<input type="checkbox"/>	<input type="checkbox"/>	<input type="checkbox"/>	<input type="checkbox"/>	<input type="checkbox"/>	<input type="checkbox"/>	<input type="checkbox"/>

5. How much did pain interfere with your normal activities last week?

“0” “10”
No interference Worst interference possible

0	1	2	3	4	5	6	7	8	9	10
<input type="checkbox"/>	<input type="checkbox"/>	<input type="checkbox"/>	<input type="checkbox"/>	<input type="checkbox"/>	<input type="checkbox"/>	<input type="checkbox"/>	<input type="checkbox"/>	<input type="checkbox"/>	<input type="checkbox"/>	<input type="checkbox"/>

Healthcare Use

Please write your answer to each question in the boxes below.

1. How many different doctors have you seen for your pain?

2. How many times have you seen doctors in the past **THREE MONTHS** for your pain problem?

3. How many times have you gone to the Accident and Emergency Department in the past **THREE MONTHS** because of your pain?

4. How many days have you been hospitalised in the past **THREE MONTHS** because of your pain?

Brief Pain Inventory (Interference Scale)

1. In the last week, how much relief have pain treatments or medications provided? Please circle the one percentage that most shows how much relief you have received.

0%	10%	20%	30%	40%	50%	60%	70%	80%	90%	100%
No relief										Complete relief

2. Circle the one number for each item that describes how, in the last week, pain has interfered with your:

a) General activity

0	1	2	3	4	5	6	7	8	9	10
Does not interfere										Completely interferes

b) Mood

0	1	2	3	4	5	6	7	8	9	10
Does not interfere										Completely interferes

c) Walking ability

0	1	2	3	4	5	6	7	8	9	10
Does not interfere										Completely interferes

d) Normal work (includes both work outside the home and housework)

0	1	2	3	4	5	6	7	8	9	10
Does not interfere										Completely interferes

e) Relations with other people

0	1	2	3	4	5	6	7	8	9	10
Does not interfere										Completely interferes

f) Sleep

0	1	2	3	4	5	6	7	8	9	10
Does not interfere										Completely interferes

g) Enjoyment of life

0	1	2	3	4	5	6	7	8	9	10
Does not interfere										Completely interferes

Permission has been given to use this scale.

PATIENT HEALTH QUESTIONNAIRE (PHQ-9)

Over the *last 2 weeks*, how often have you been bothered by any of the following problems? (*please circle the most appropriate answer*)

	Not at all	Several days	More than half the days	Nearly every day
1 Little interest or pleasure in doing things	0	1	2	3
2 Feeling down, depressed, or hopeless	0	1	2	3
3 Trouble falling or staying asleep, or sleeping too much	0	1	2	3
4 Feeling tired or having little energy	0	1	2	3
5 Poor appetite or overeating	0	1	2	3
6 Feeling bad about yourself—or that you are a failure or have let yourself or your family down	0	1	2	3
7 Trouble concentrating on things, such as reading the newspaper or watching television	0	1	2	3
8 Moving or speaking so slowly that other people could have noticed. Or the opposite—being so fidgety or restless that you have been moving around a lot more than usual	0	1	2	3
9 Thoughts that you would be better off dead, or of hurting yourself	0	1	2	3

10. If you checked off *any* problems, how *difficult* have these problems made it for you to do your work, take care of things at home, or get along with other people?

Not difficult at all _____

Somewhat difficult _____

Very difficult _____

Extremely difficult _____

PHQ-9 is adapted from PRIME MD TODAY, developed by Drs Robert L. Spitzer, Janet B.W. Williams, Kurt Kroenke, and colleagues, with an educational grant from Pfizer Inc. For research information, contact Dr Spitzer at rls8@columbia.edu. Use of the PHQ-9 may only be made in accordance with the Terms of Use available at <http://www.pfizer.com>. Copyright ©1999 Pfizer Inc. All rights reserved. PRIME MD TODAY is a trademark of Pfizer Inc.

Committed Action Questionnaire

Directions: Below you will find a list of statements. Please rate the truth of each statement as it applies to you by circling a number. Use the following rating scale to make your choices. For instance, if you believe a statement is “Always True”, you would circle the 6 next to that statement.

0 Never True	1 Very Rarely True	2 Seldom True	3 Sometimes True	4 Often True	5 Almost Always True	6 Always True
-------------------------------	-------------------------------------	--------------------------------	-----------------------------------	-------------------------------	---------------------------------------	--------------------------------

1	I am able to persist with a course of action after experiencing difficulties	0	1	2	3	4	5	6
2	When I fail in reaching a goal, I can change how I approach it	0	1	2	3	4	5	6
3	If I experience pain from something I do, I will avoid it no matter what it costs me	0	1	2	3	4	5	6
4	I can remain committed to my goals even when there are times that I fail to reach them	0	1	2	3	4	5	6
5	When a goal is difficult to reach, I am able to take small steps to reach it	0	1	2	3	4	5	6
6	I act impulsively when I feel under pressure	0	1	2	3	4	5	6
7	I prefer to change how I approach a goal rather than quit	0	1	2	3	4	5	6
8	I am able to follow my long terms plans including times when progress is slow	0	1	2	3	4	5	6
9	When I fail to achieve what I want to do, I make a point to never do that again	0	1	2	3	4	5	6
10	I approach goals in an “all-or-nothing” fashion	0	1	2	3	4	5	6
11	I get stuck doing the same thing over and over even if I am not successful	0	1	2	3	4	5	6
12	I find it difficult to carry on with an activity unless I experience that it is successful	0	1	2	3	4	5	6
13	When I make commitments, I can both stick to them and I can change them	0	1	2	3	4	5	6
14	I am more likely to be guided by what I feel than by my goals	0	1	2	3	4	5	6
15	I am able to pursue my goals both when this feels easy and when it feels difficult	0	1	2	3	4	5	6
16	I am able to persist in what I am doing or to change what I am doing depending on what helps me reach my goals	0	1	2	3	4	5	6

0 Never True	1 Very Rarely True	2 Seldom True	3 Sometimes True	4 Often True	5 Almost Always True	6 Always True
---	---	--	---	---	---	--

17	If I make a commitment and later fail to reach it, I then drop the commitment	0	1	2	3	4	5	6
18	I am able to let go of goals that I repeatedly experience as unreachable	0	1	2	3	4	5	6
19	I am able to incorporate discouraging experiences into the process of pursuing my long term plans	0	1	2	3	4	5	6
20	I am able to accept failure as part of the experience of doing what is important in my life	0	1	2	3	4	5	6
21	If I feel distressed or discouraged, I let my commitments slide	0	1	2	3	4	5	6
22	I get so wrapped up in what I am thinking or feeling that I cannot do the things that matter to me	0	1	2	3	4	5	6
23	If I cannot do something my way, I will not do it at all	0	1	2	3	4	5	6
24	I can accept my limitations and adjust what I do accordingly	0	1	2	3	4	5	6

AAQ-2

Below you will find a list of statements. Please rate how true each statement is for you by circling a number next to it. Use the scale below to make your choice.

1	2	3	4	5	6	7
never true	very seldom true	seldom true	sometimes true	frequently true	almost always true	always true

1. My painful experiences and memories make it difficult for me to live a life that I would value.	1 2 3 4 5 6 7
2. I'm afraid of my feelings.	1 2 3 4 5 6 7
3. I worry about not being able to control my worries and feelings.	1 2 3 4 5 6 7
4. My painful memories prevent me from having a fulfilling life.	1 2 3 4 5 6 7
5. Emotions cause problems in my life.	1 2 3 4 5 6 7
6. It seems like most people are handling their lives better than I am.	1 2 3 4 5 6 7
7. Worries get in the way of my success.	1 2 3 4 5 6 7

CPAQ-8

Directions: Below you will find a list of statements. Please rate the truth of each statement as it applies to you by circling a number. Use the following rating scale to make your choices. For instance, if you believe a statement is “Always True”, you would circle the 6 next to that statement.

0	1	2	3	4	5	6
Never	Very	Seldom	Sometimes	Often	Almost	Always
True	Rarely	True	True	True	Always	True
	True				True	

1. I am getting on with the business of living no matter what my level of pain is	0	1	2	3	4	5	6
2. Keeping my pain level under control takes first priority whenever I am doing something	0	1	2	3	4	5	6
3. Although things have changed, I am living a normal life despite my chronic pain	0	1	2	3	4	5	6
4. Before I can make any serious plans, I have to get some control over my pain	0	1	2	3	4	5	6
5. I lead a full life even though I have chronic pain	0	1	2	3	4	5	6
6. When my pain increases, I can still take care of my responsibilities	0	1	2	3	4	5	6
7. I avoid putting myself in situations where my pain might increase	0	1	2	3	4	5	6
8. My worries and fears about what pain will do to me are true	0	1	2	3	4	5	6

Thank you. Please check you have not missed any pages.

Appendix F. Chapter 10: Design and System Description of iACT-CEL

Design and System Description:

The design process was started with wireframing using software such as omnigraffle (<https://www.omnigroup.com/omnigraffle>), Adobe Illustrator and Adobe Photoshop programs were used to add in the User Interface elements. The system behind the iACT-CEL program is optimised for mobile devices and iPad devices. Users can access the website from any laptop/computer browsers and use the system whenever it seems appropriate.

Major technical features of the program:

1. *Creation of individual account login information for users*
 - (a) Ability to login with given unique credentials
 - (b) Secure Sockets Layer (SSL) Authentication process to ensure confidentiality of input data.
 - (c) Creation of user database to store last logged in information.
2. *Creation of compulsory modules and optional modules:*
 - (a) Creation of compulsory modules code using MySQL database with 2 level factor authentication for admin to approve each patient before proceeding to the next module.
 - (b) Sub division of database architecture structure to store 3 separate core modules with option to expand and go into optional modules.
 - (c) Setting up of admin database for easy edit of data by administrator
 - (d) Creation of patient relationship management system in web admin for admin to track patient progress.
 - (e) Setting up security access layer to differentiate between optional and compulsory module.

- (f) Creation of embedded code to accept Vimeo/Youtube/3rd party related embedded codes related to the video and audio uploads.
- (g) Extraction of input data by patients to Comma Separate Value file (.csv) which can be opened in Excel.

3. *Data storage:*

- (a) All data are stored on a hosting server by GoDaddy (<https://sg.godaddy.com/>).
- (b) All data can only be read/edit/download/uploaded through the hosting server CPanel System accessible through the main account.

4. *Data synchronization:*

- (a) The data can be synchronized with the server and the website at all times.
- (b) Emails and communication can also be made through the Simple Mail Transfer Protocol (SMTP) setup in the server.

5. *The software framework allows for future upgrades to the iACT-CEL program.*

Development Process

The design phase is divided into 2 phases. The first phase involved the creation of the website using HTML 5 and Javascript technology and the second phase involved a creation of the database and website administrator panel using PHP, MySQL for the therapist to monitor participants' input and responses. Video and audio materials were hosted on both Youtube and Vimeo sites.

Appendix G. Chapter 10: Step by Step Guide to Navigate the iACT-CEL Program

Click the 'Sign in' button on the top right corner of the website.

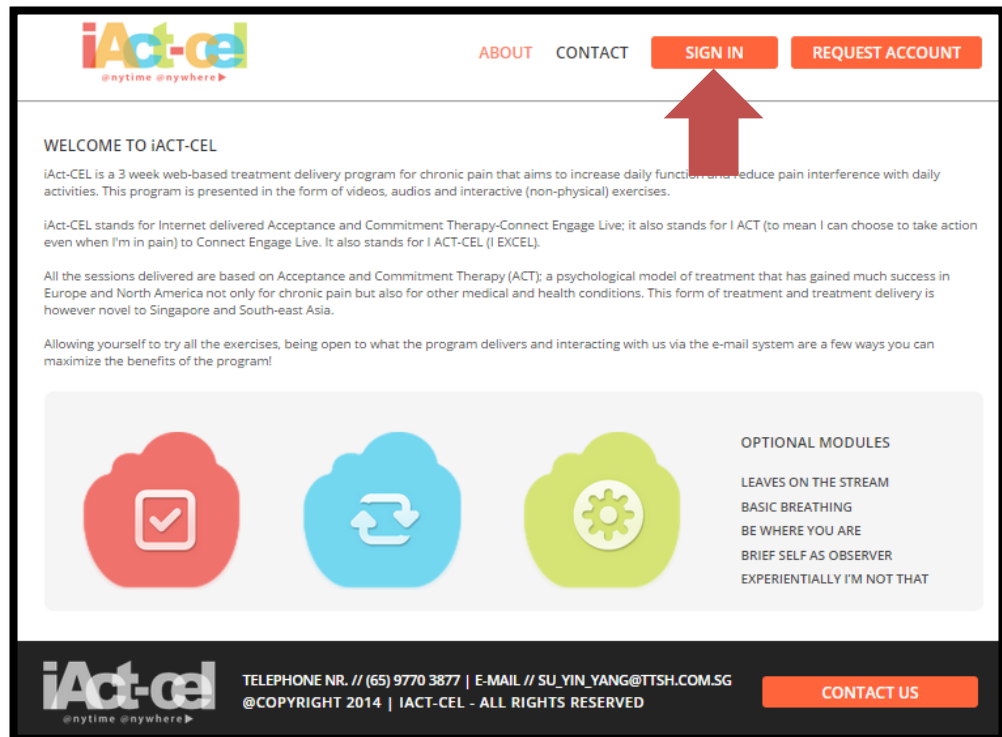

Key in your username and password as indicated on the welcome email and click the 'SIGN IN' button when you're done [Please contact us if you have forgotten your username or password given to you]



Click 'OK' when the welcome pop-up message shows up.

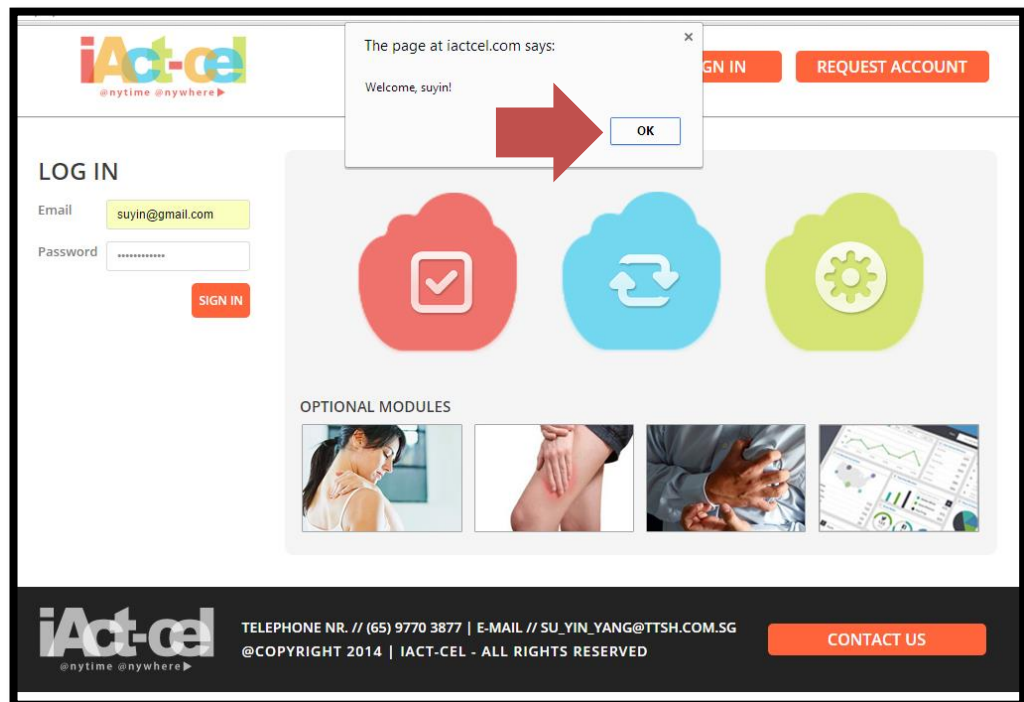

1. You will be directed to a webpage that looks like this

iAct-cel anytime anywhere

ABOUT CONTACT [Welcome, suyin](#) [LOG OUT](#)

WELCOME TO iACT-cel

Lesson 1 & 1.3 from iactcelshannon on Vimeo.

OPTIONAL MODULES

- LEAVES ON THE STREAM
- BASIC BREATHING
- BE WHERE YOU ARE
- BRIEF SELF AS OBSERVER
- EXPERIENTIALLY I'M NOT THAT

"The significant problems we face cannot be solved at the same level of thinking we were at when we created them" – Albert Einstein –

iAct-cel TELEPHONE NR. // (65) 9770 3877 | E-MAIL // SU_YIN YANG@TTSH.COM.SG
@COPYRIGHT 2014 | iACT-CEL - ALL RIGHTS RESERVED [CONTACT US](#)

2. Click on the right arrow button to play the video

WELCOME TO iACT-cel

Lesson 1 & 1.3 from iactcelshannon on Vimeo.

Play

Adjust the volume of the video by clicking on the blue bars as indicated

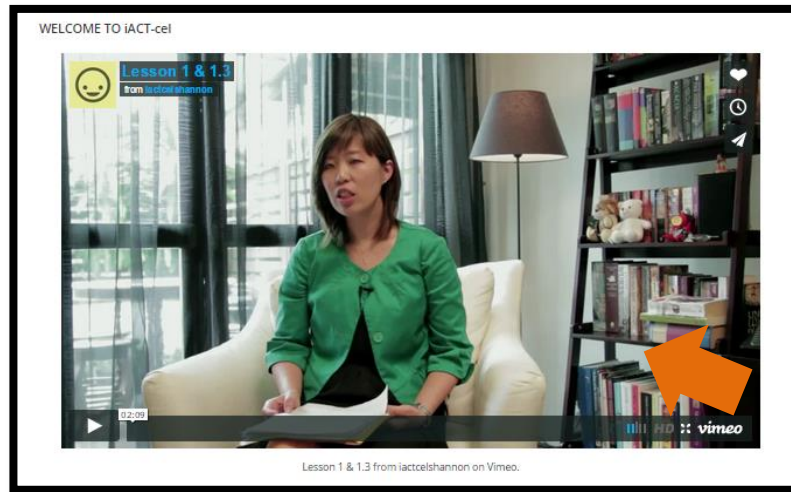

Clicking on the 'four corners' as indicated, increases the video size to full screen or normal as your preference

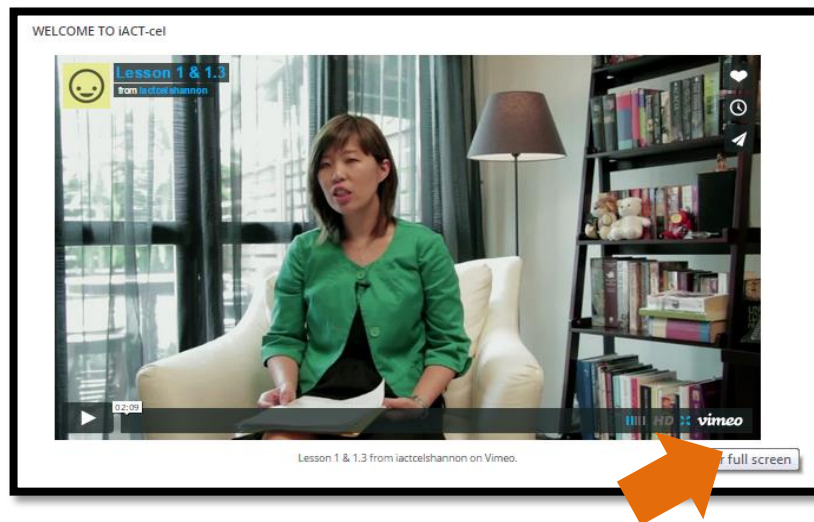

Starting a session

Each module is represented by the red, blue and green icons as shown below. Click on the appropriate icon matching the session you are starting for the week (an email reminder will also be sent to you).

WELCOME TO iACT-cel



Lesson 1 & 1.3 from iactcelshannon on Vimeo.



ACCEPT





OPTIONAL MODULES

- LEAVES ON THE STREAM
- BASIC BREATHING
- BE WHERE YOU ARE
- BRIEF SELF AS OBSERVER
- EXPERIENTIALLY I'M NOT THAT

"The significant problems we face cannot be solved at the same level of thinking we were at when we created them" – Albert Einstein ~

Click the "Accept" icon to start

You will be directed to the first/second session of the module. Click 'START SESSION' to ensure the data you entered is saved.



Welcome, suyin

ABOUT CONTACT [LOG OUT](#)

MODULE 1

ACCEPT

"When you change the way you look at things, the things you look at change"

~ Wayne Dyer ~

Session 1

Why I Avoid?

[START SESSION](#)

SESSION 1 : WHY I AVOID

- Session 1.1: Intro
- Session 1.2: Pain Avoidance Cycle
- Session 1.3: How I Cope
- Session 1.4: Quality of Your Life
- Session 1.5: Unwelcomed Visitor
- Session 1.6: My Feelings Right Now
- Session 1.7: Struggle Feelings

SESSION 2 : YOU ARE NOT YOUR THOUGHTS



TELEPHONE NR. // (65) 9770 3877 | E-MAIL // SU_YIN YANG@TTSH.COM.SG

@COPYRIGHT 2014 | IACT-CEL - ALL RIGHTS RESERVED

[CONTACT US](#)

You can start your session accordingly. Fill in your answers on the blank spaces shown in the sessions (you do not need to fill in all the blank spaces).

MODULE 1 : ACCEPT

Previous Session

Exercise: How I cope

For most people in treatment for chronic pain, the experience of pain has become a barrier in their life. They also spend quite a lot of time trying to reduce or control their pain. We ask you to take some time to reflect on whether you are doing this and on how effective it is. Consider your own treatments and other methods you have been using. For example, resting, stopping work, taking medication, having procedures, and avoiding certain activities. How effective have these been? Are these methods helping you to do more of the things you want to do? Complete the following exercise and see what there is to learn.

In the left hand column, one beneath the other, write down some of the coping strategies you have tried to reduce your pain. Now think about each of these strategies for a moment. Try to remember when you used the strategy in the past few weeks. And then answer the following questions for each strategy.

1. Was your strategy effective? In other words, did it help you to reduce the pain, to avoid it, to get rid of it? You can answer yes, a little, moderately, or no. Type your answer in the second column.
2. Next consider your quality of life. For each strategy in the left-hand column, ask yourself how it has impacted on your quality of life. Note down your answers in the right hand column.

SESSION 1 : WHY I AVOID

Session 1.1: Intro

Session 1.2: Pain Avoidance Cycle

Session 1.3: How I Cope

Session 1.4: Quality of Your Life

Session 1.5: Unwelcomed Visitor

Session 1.6: My Feelings Right Now

Session 1.7: Struggle Feelings

SESSION 2 : YOU ARE NOT YOUR THOUGHTS

WHAT HAVE YOU TRIED TO REDUCE OR COPE WITH YOUR PAIN?	HOW EFFECTIVE WAS IT?	LONG TERM RESULTS ON QUALITY OF LIFE

If you decide to log out halfway through the program, take note: Double click the blank spaces the next time you log in to see your saved answers.

1. Was your strategy effective? In other words, did it help you to reduce the pain, to avoid it, to get rid of it? You can answer yes, a little, moderately, or no. Type your answer in the second column.
2. Next consider your quality of life. For each strategy in the left-hand column, ask yourself how it has impacted on your quality of life. Note down your answers in the right hand column.

SESSION 2 : YOU ARE NOT YOUR THOUGHTS

WHAT HAVE YOU TRIED TO REDUCE OR COPE WITH YOUR PAIN?	HOW EFFECTIVE WAS IT?	LONG TERM RESULTS ON QUALITY OF LIFE
erfwer		
erfwer		
_grgwegv		

For bigger blank spaces, previously saved answers should be shown in the box without the need for double clicking.

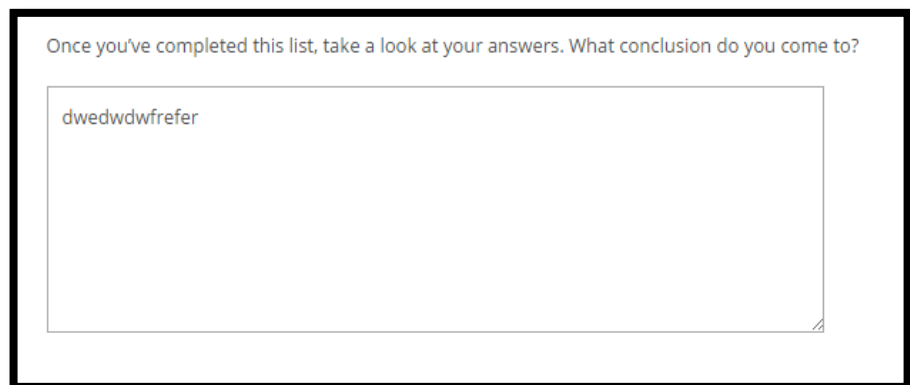

Click the 'CONTINUE' button after your session and click 'OK' once you have completed the whole session.

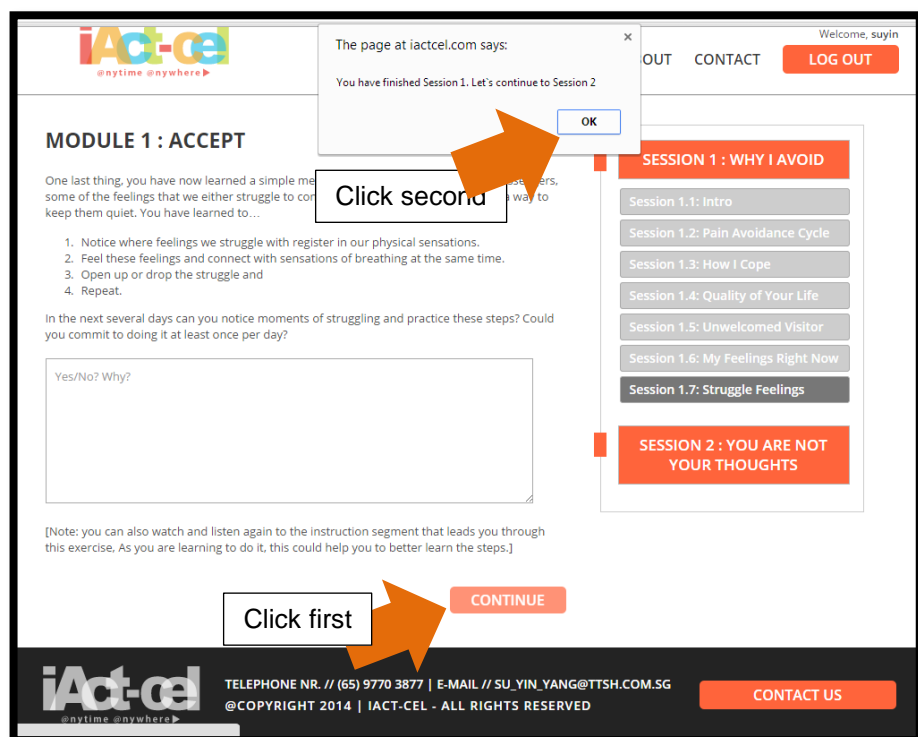

You will be redirected to Session 2. However, you are not required to start Session 2 immediately. Click the 'LOG OUT' button located on the top right-hand corner once you decided that you've done enough for the day.

MODULE 1
ACCEPT

"When you change the way you look at things, the things you look at change"

~ Wayne Dyer ~

Session 2
You Are Not Your Thoughts

START SESSION

SESSION 1 : WHY I AVOID

SESSION 2 : YOU ARE NOT YOUR THOUGHTS

Session 2.1: Intro

Session 2.2: Struggle Switch

Session 2.3: Passengers on the Bus

Session 2.4: Acceptance in Action

Session 2.5: FAQs

Session 2.6: Ratings



Appendix H. iACT-CEL Treatment Protocol [Condensed Version]

iACT-CEL

@nytime@nywhere

(An ACT based online chronic pain program)

Face-to-Face Session 1

For this session, we are going to do an exercise with the Chinese Finger Trap. ***[Therapist demonstrates here how the Chinese Finger Trap works. Note: The construction of the tube is such that pulling and stretching the tube in attempts to remove the fingers elongates it and shrinks the diameter, thus increasing its hold on the fingers]*** What's happening here? See, the harder you pull, the smaller the tube gets and the tighter it holds your fingers. Maybe this situation with pain, distress, and the other experiences come with it, is something like this trap. Maybe there is no healthy way to get out of pain or distress once we are stuck in it, such as when it is a chronic condition, and any attempt to do so just restricts your room to move. Have you noticed something else about this little tube? With this little tube, the only way to get some room is to push your fingers in, which makes the tube bigger. Maybe you need to come at this situation from a whole different angle, different than what your mind tells you to do with your experience of suffering.

Is this "moving in" something you could do when you are struggling to get out of experiences outside of session? Let's identify some possible situations. The more you struggle, the more restricted you are in your movements. If you let go of the struggle, you will have more choices in living out the life the way you want. Does this make sense? ***[Therapist answers participants' questions accordingly]***

Let's move on to a small exercise. You have seen for yourself in this demonstration how your struggle with pain might not be helping you get to where you want to be in life. Consider now some possible goals you might want to achieve by the end of the program.

Exercise: Setting Goals [pen and paper exercise]

What are some goals you would like to set for yourself to achieve by the end of the program? You can choose an area of life that you would like to work on first.

Goal 1

Goal 2

Goal 3

What are some thoughts that might try to stand in your way?

What emotions might crop up, both before and during your action?

Are you prepared to experience the pain and negative emotions that accompany your goals? (wait for participant's response). Make sure these are not used as reasons to stop you from achieving what you've set out to do.

Welcome [Therapist presented video]

[Condensed script] Hi there, I am glad you are here. Did you have a chance to reflect on the Chinese finger trap demonstration? Remember this? (show Chinese Finger Trap). Have you begun to think of your goals or to work on the ones you have identified? If yes, did you notice whether you encountered any barriers, such as pain or other feelings? If you remember, (a) avoiding traps, (b) working on your goals and (c) managing these barriers are why we are here.

Do you ever feel that you are struggling with pain? Or that it is a big issue in your life? Or that the pain is in control?...At the same time, do you have goals for a better life? Are there things you want to achieve? And, here I don't mean just get rid of the pain, I mean positive things, such as with family or friends, your work or hobbies, or simply enjoying yourself in whatever you like to do.

[Therapist introduces herself, the rationale of the program, program format including interactive components on the program here]

Instructions to complete each module are online. You are encouraged to complete all of them in the way they are laid out. We can guarantee that the more you engage with the exercises the greater is your potential to learn and benefit. Essentially, there are 3 different skills or capacities we want to develop together. These include the ability to 'accept' or be 'open', 'connect' and 'engage'. If you have goals in your life, and these goals are important to you, the methods here are a potentially powerful way for you to reach them.

MODULE 1: ACCEPT

Session 1: The Problem with Avoidance [Therapist presented video]

[Condensed script] In the first session that I met you, you were introduced to The Chinese Finger Trap exercise. This is a summary of what we talked about.

Summary:

1. The more you struggle with pain the more it restricts your movements.
2. Letting go of the struggle, gives you more choice in living the life you want.
3. Moving toward what we don't like is unusual- and can be quite empowering.

In this session, we are going to build acceptance and openness.

[Therapist elaborates here what openness means]

Consider in your experience whether actions to reduce pain make life better, freer, and bigger; or do they make it smaller, more restricted, and more dominated by pain? ***[Therapist gives examples here of how avoiding pain can restrict life].***

Does experience show that trying to escape pain makes life better or not?

Any method to avoid pain, if used excessively will create GREATER PROBLEMS. Trying to bury pain doesn't make it disappear. You then end up in a cycle where the more you try to avoid pain the worse you feel!

[Therapist presents here the avoidance cycle and walks participants through the cycle explaining what happens when avoidance of pain happens]

Metaphor: Tug of War [Animation with standard script used by therapist in narration]

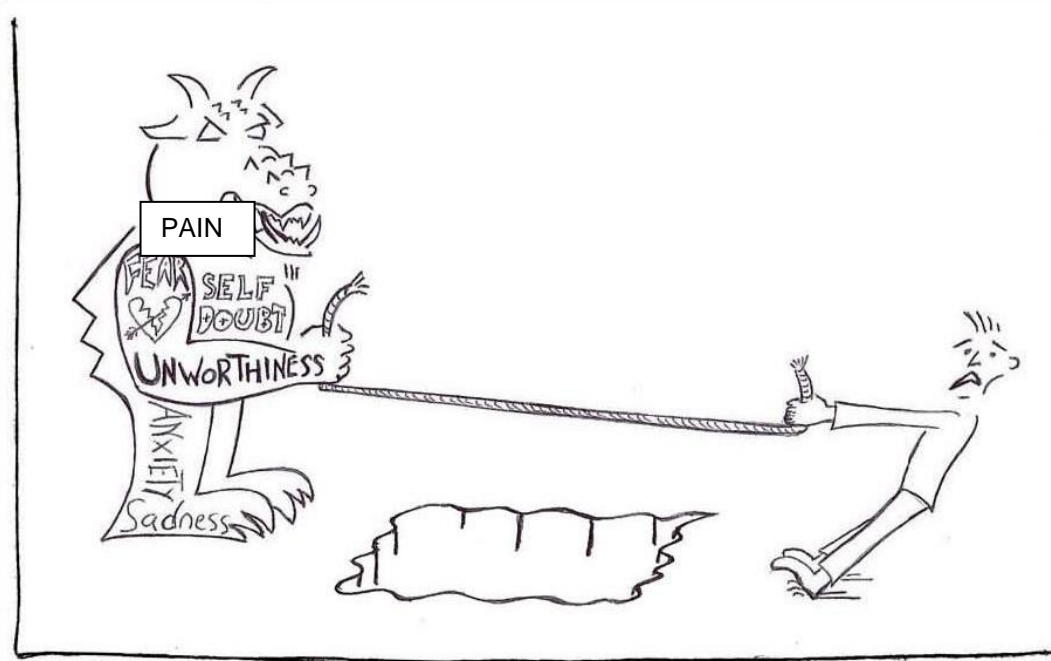

Exercise: How I cope? [Text-based Exercise]

For most people in treatment for chronic pain the experience of pain has become a barrier in their life. They also spend quite a lot of time trying to reduce or control their pain. We ask you to take some time to reflect on whether you are doing this and on how effective it is. Consider your own treatments and other methods you have been using, for example, resting, stopping work, taking medication, having procedures, and avoiding certain activities. How effective have these been? Are these methods helping you to do more of the things you want to do? Do they ever interfere with this? Complete the following exercise and see what there is to learn.

In the left hand column, one beneath the other, write down some of the coping strategies you have tried to reduce your pain. Now think about each of these strategies for a moment. Try to remember when you used the strategy in the past few weeks. And then answer the following questions for each strategy.

1. Was your strategy effective? In other words, did it help you to reduce the pain, to avoid it, to get rid of it? You can answer yes, a little, moderately, or no. Type your answer in the second column.
2. Next consider your quality of life. For each strategy in the left-hand column, ask yourself how it has impacted on your quality of life. Note down your answers in the right hand column.

WHAT HAVE YOU TRIED TO REDUCE OR COPE WITH YOUR PAIN?	HOW EFFECTIVE WAS IT?	LONG TERM RESULTS ON QUALITY OF LIFE

Once you've completed this list, take a look at your answers. What conclusions do you come to?

Exercise: Avoidance [Text-based exercise]

Now ponder on the next exercise for a little while. Then state about how the quality of your life would change if these issues were not present.

Some examples:

- If I weren't so anxious I would have taken up that promotion at work.
- If I didn't have pain I would have gone on a holiday with my best friend.
- If it weren't for pain I would spend more quality time with my family.

If it weren't for.....

I would.....

If it weren't for.....

I would.....

If it weren't for.....

I would.....

If it weren't for.....

I would.....

If it weren't for.....

I would.....

You have now reflected on how you would live if you were free of pain, anxiety, distress and so on. This exercise is to increase your awareness of what you would do if you weren't held back by pain and distress.

Metaphor: Joe the Bum/ Unwelcome Guest [Animation with standard script used by therapist in narration]

[Text on page] What is the effect that you enjoy the party and you bump into Joe on occasion? Just like pain, being the unwelcome guest, are you able to let it go and focus more on living your life in the moment?

Exercise: Joe the Bum [Text-based exercise]

In the following exercise, list down below some things that have stopped you from enjoying your 'party'.

1.
2.
3.
4.
5.

[Text on page] Are you ready to welcome Joe into the party? You don't have to like him. You don't have to like the way he makes you feel. But take a look at the costs of not being willing to have him there. When this party started, it was all about living a life you valued. Being with your friends and family, really connecting with them and doing things you enjoy. The more unwilling you are for Joe to be there, the more time you spend trying to keep him out and the less time you have living a life you value.

Experiential Exercise: Connect, Breathe, Open up [Therapist presented video]

[Use standard Connect, Breathe, Open up script here. The following are main points that should be included]

1. Simply Observe: Identify where emotional experiences are located in the body and focus on the details of these with interest and curiosity.
2. Breathe. Include with these sensations a focus on, or connection with, the breathing.
3. Open up. Notice any tendencies to move away or avoid the experiences and move deeper into them, embrace them, or make room for them instead. Instead of defending against them allow them to be present.

As you proceed through this exercise, what feelings showed up for you? And, please turn your focus on your current experience and see if you can notice what feelings are showing up now? Do you notice whether you are inclined to struggle with, or push away any of these feelings? Write some of the feelings present for you right now in the box below. If as you write them down, more show up, write them down too.

My feelings right now [Text-based exercise]:

1.
2.
3.

[Text on page] One last thing, you have now learned a simple method of addressing some of life's passengers, some of the feelings that we either struggle to control, suppress, or simply follow, as a way to keep them quiet. You have learned to...

- 1) Notice where feelings we struggle with register in our physical sensations.
- 2) Feel these feelings and connect with sensations of breathing at the same time.
- 3) Open up or drop the struggle and
- 4) Repeat.

In the next several days can you notice moments of struggling and practice these steps? Could you commit to doing it at least once per day?

Comments

Yes? No?

Session 2: More on Openness and You Are Not Your Thoughts [Therapist presented video]

[Condensed script] Hi there. How are you doing with the 3 part skill: 1) Noticing feelings, 2) Breathing and 3) Opening up? Remember, these are the simple steps that can save us from wrestling with our “unwanted guests” so that we can “enjoy the party”. Before we start on today’s lesson, let’s recall what we learnt from the previous lesson.

Summary

1. Avoidance strategies may reduce pain in the short term but in the long term stops us from living the life we want.
2. It’s not your job to win the tug of war, maybe it’s time to drop the rope.
3. Trying to block an ‘unwelcome guest’ stops you from enjoying your party.

In order to bring about change where it is wanted (if we are not leading the life we’d like to live and are capable of living), we first have to accept and experience the situation as it is.

What acceptance and readiness are not?

[Therapist explains what acceptance and readiness encompass] Acceptance is an active, positive embracing of life. It is not about passively having to accept life the way it is. Acceptance is not the same as enjoying your pain. Rather, we ask you to make room for it, to familiarise yourself with it as part of your life.

As for readiness, it’s not the same as trying. When asked if you are ready to accept pain, you can’t answer with ‘maybe’ or ‘I’ll try’. When you say

you'll try, usually it means you are not ready and not willing. Readiness does not mean maybe, tomorrow, next week, next year or another time. Readiness has only two options: yes or no. Readiness is 100% now. It does not matter how much pain you have when you are ready.

Metaphor: The Struggle Switch [Video with standard script used by therapist in narration]

[Text on page] In the coming week, try to notice when you turn on the struggle switch. What effect does it have on you? Is it true that the struggle increases the more you fight it? You can choose to type some of your comments in the box below.

My Comments

Metaphor: Passengers on the Bus [Animation with standard script used in therapist narration]

[Text on page] Think about it. Is this your reaction to pain, to things you don't want in your life, to negative emotions, sensations, thoughts? Where are you in your life right now? Are you ready to make the change?

Exercise: Passengers on the Bus [Text-based Exercise]

So now, consider this and fill in the text box.

Which 'passenger(s)' might be threatening you now?

1.
2.
3.
4.
5.

What has this all cost you? Think about money, time, energy, things you haven't done. Think too about the effects on your work, relationships and health.

--

What are the directions you want to take in your life? What are some of your specific goals?

1.
2.
3.
4.
5.

Maybe, now you feel angry, disappointed, hopeless or sad and may even think of giving up. All we ask is that you notice your emotions without judging and bear them for a moment. Let's try the next few exercises and see what shows up for you.

Experiential Exercise: Expansion Exercise [Video with standard script used in therapist narration]

Exercise: Acceptance in Action [Text-based exercise]

It is important that you take what you have learnt in this lesson and apply it into practice. In the box below, write down an action or activity that you have avoided recently. It should be an activity that does form part of a meaningful life. Choose an activity that can be carried out without too much preparation, and is not too difficult.

Here are some examples:

-I'm going to talk to my partner about going for a show this weekend

-I'm going to go shopping with my friends this weekend

What is your activity going to be?

We would like you to carry out your activity in the next 2 days and to allow any stress it causes you. If in doubt, think about what you have learnt in the past week.

My Comments

Exercise: Diary Ratings [Text-based exercise]

We have come to the end of Session 2 in this module, for you to see how well you have progressed and for us to know how we can make this treatment experience more useful for you, we ask that you rate the following pain items.

Please would you rate the following on a scale of 0-10 where '0' = not at all and '10'= completely.

1. How much did you struggle with pain this week?

Not at all	0	1	2	3	4	5	6	7	8	9	10	Completely
------------	---	---	---	---	---	---	---	---	---	---	----	------------

2. How much did you open up to pain and distress and simply allow them to be there?

Not at all	0	1	2	3	4	5	6	7	8	9	10	Completely
------------	---	---	---	---	---	---	---	---	---	---	----	------------

3. To what extent were you "living in the present" rather than focusing on your thoughts, the past or future?

Not at all	0	1	2	3	4	5	6	7	8	9	10	Completely
------------	---	---	---	---	---	---	---	---	---	---	----	------------

4. How often did you follow your goals and values?

Not at all	0	1	2	3	4	5	6	7	8	9	10	Completely
------------	---	---	---	---	---	---	---	---	---	---	----	------------

MODULE 2: CONNECT

Session 1: Acceptance Including Thoughts [Therapist presented video]

[Condensed script] Hello again. The aim of this session is to build up the ability to deal more successfully with our own mind and the thoughts it produces. We sometimes call this “getting out of your mind” and it can be a very tricky and a very interesting challenge to do! It is impossible to stop thinking, especially deliberately. When we deliberately try to stop thinking, we create a thought that goes “we shouldn’t be thinking a thought,” and we try to follow it. Try this “ Don’t think of a durian” for the next minute....(pause) If you are like me, and most people for that matter, try as you might following this instruction is nearly impossible to do. What is striking about this is that the thoughts and feelings we try to suppress can end up coming to the fore all the more strongly.

It’s like trying to push a ball under water. However hard you push, the ball springs back again as soon as you stop ***[Therapist demonstrates this action]***. It is entirely natural to attempt to push away or suppress thoughts and feeling as a way to limit their effects – at the same time, you can see that there are limits in our ability to do this. It often does not work.

Exercise: What are you thinking right now? [Text-based Exercise]

Try typing down your thoughts as they run through your mind right now. Take a few minutes and type down as many thoughts as you can, while they are occurring in the space provided below:

What did you find? How many thoughts were you able to describe? As you typed, did other thoughts also pop up? If you stumbled for a moment and you thought something like, “I’m not thinking anything,” did you understand that this too was a thought? It can be useful to understand what our minds are for and what they are designed to do. Our minds are designed to look out for potential problems, to analyse them, and to solve them; to protect us from anything that might be even remotely threatening. The mind leads us to ask pointless questions that only worsen the pain. So do you ever find yourself doing one or more of the following:

1. Thinking the same thoughts over and over again.
2. Losing track of what is going on around you because you are stuck in your thoughts.
3. Feeling stuck in the past or the future.
4. Judging, evaluating or comparing.
5. Labelling experiences as good or bad.
6. Feeling your thoughts are racing, repetitive, or confusing.

If the answer is “yes” this may signal the need to learn to be more open to the process of thinking, how thoughts work, and to the content of thoughts, without allowing them to dominate you. This is to make sure that when you want to do something your mind does not distract you or your thoughts tell you not to do it. Let’s try an exercise now. It’s called I am having the thought that...

Exercise: I am having the thought that [Therapist presented video and text-based exercise]

In the box below, at the 1st column list down some of the thoughts that have distressed or discouraged you. In the 2nd column add the phrase I'm having the thought that in front of the thoughts that you have selected. In the 3rd column now, add the phrase I notice I'm having the thought that.

Thoughts that have distressed/discouraged me	I'm having the thought that...	I notice I'm having the thought that...

Could you practice this exercise? How about one or more times each day? For the next week, how about if you apply this process in your own self-talk. By the way, you can also apply similar labels to your thoughts, memories, feelings, sensations, and urges. For example, you can say "I'm noticing that I am having a feeling of anxiety" or I am noticing that I have a goal to work on and I am having the urge to go play in the sunshine." You don't have to talk this way out loud to other people, but you can if you want to.

Now let's practice quieting our minds down for a moment.

Exercise: Awareness of your experience [Video with therapist narration.

Video was designed to include a running script of this experiential exercise]

How's Your Experience So Far? [Therapist presented video]

Take a look back at the past week. How did you approach this program? Did you set aside time for it? What did you do if an exercise did not work straight away? What were the most common thoughts that occurred to you? Do you recognise a recurring pattern with regard to your response to pain? Do you recognise your automatic responses? Being aware of them can help you to do things differently from now on. Are you someone who gives up quickly? Can you now give yourself more time? Are you someone who needs to see immediate results and a quick fix? Can you allow more time for the small steps? Do you have a tendency to race through all the exercises without really engaging in them? Can you slow down, take time to understand, not only on an intellectual level but also connecting at an emotional one?

Session 2: In the Present Moment [Therapist presented video]

[Condensed script] I am glad that you are here. Consider your week so far. Are you working on your goals, including building your openness skills? If yes, that's great! If not, what has stood in your way? So, perhaps you will remind yourself of the purpose of this journey, see if that purpose remains important, and recommit yourself to doing this journey. In this session, we want to talk about attention to the present moment – this is a part of what we call your awareness or connection skills.

[Therapist elaborates on the concept of attention and awareness and differentiates between living with awareness and without].

The following exercise called 'Anchoring' can help bring your attention to what is happening in the present moment.

Experiential Exercise: Anchoring [Video with standard script used in therapist narration. Video includes a running script of the exercise]

Stop and Think [Therapist presented video to encourage participants to continue to engage in treatment]

[Script] If you have managed to engage in the exercises so far, you are now able to notice physical discomfort, negative emotions and thoughts and to be in contact with them (not avoid). You are less affected by what your mind tells you to do and no longer automatically treat your thoughts as reality. These skills do require constant practice. It is normal to often fall back into old patterns. That is all part of the process. What matters most is that you start to notice it and that you are able to adjust. You start to move with the flow of life, rather than fighting or controlling it. You will have a keener awareness of what you do want in your life, and make space for pain and other things that you are not comfortable with.

There are many other ways that you can learn to get present. Try some of these exercises.

Experiential Exercise: Notice 5 Things [Therapist presented video]

[Script and text on page] This is yet another simple exercise to center yourself and engage with your environment. Practice it throughout the day, especially any time you find yourself getting caught up in your thoughts and feelings.

1. Pause for a moment.
2. Look around and notice five things that you can see.
3. Listen carefully and notice five things that you can hear.
4. Notice five things that you can feel in contact with your body (for example, your watch against your wrist, your trousers against your legs, the air on your face, your feet upon the floor, your back against the chair).
5. Finally do all of the above simultaneously.

Let's try another exercise.

Experiential Exercise: Observing the breath [Audio file]

[Text on page] Now, listen and follow through with The Chessboard metaphor.

The Chessboard Metaphor [Video with standard script in therapist narration]

Experiential Exercise: The Observing Self [Audio file]

[Text on page] How was that experience for you? Are there any thoughts you would like to share?

My Comments

Exercise: Diary Ratings [Text-based exercise]

[Use same item ratings as Module 1, Session 1 diary ratings here]

MODULE 3: ENGAGE

Session 1: What do you want out of life? [Therapist presented video]

[Condensed script] Taking time to identify what is important to us and then taking steps to achieve these things can help to create a rich, full and meaningful life. The process of identifying what is important to us is known as setting our values. This process will help you to build on what we call engagement skills.

Well, values are the choices we can make about the kind of person we want to be and the kind of life we want to lead. Values are like goals because, when chosen carefully, both can reflect our desires and what we hold as important. The different is that values are ongoing, like being a loving partner, or maintaining physical fitness, and goals are achievements that we can succeed in making, like joining a gym, taking a 20 min walk three times this week. When life seems filled with troubles to deal with or avoid, values can be very useful, they give direction, so the choices we make feel meaningful. The other side of values represents the challenges to finding, knowing and following what we want. The following are the main challenges:

1. It can be sad or painful when we realise we have failed to follow our values.
2. Our mind often dismisses values as impossible and so we dismiss them too.
3. Often we confuse other people's expectations or wishes with our own, and can end up doing what other people want and not what we want.

If you encounter any of these challenges, you are not alone, we all encounter these, and it is "completely normal" as we like to say! If you encounter these challenges this is an excellent chance to practice your skills: open up to your

feelings, as these are a part of what you want to do: and notice that you will have thoughts that your mind will send you, as the mind often does not like doing new or different things.

When you are ready, let's begin by looking at some common "ifs" and "buts" that may stop you on your journey as you make way for change in your life to take place. Remember, there's always an option for you to send your comments, and questions in the comment box at the end of every section.

Let's begin!

Metaphor: ‘Get off Your Butts’ [Therapist presented video]

[Script] This exercise is to show how habits of speech sometimes present barriers to functioning where they do not need to exist, particularly when it comes to the experiences of thoughts, feelings and sensations.

Do you ever notice the experience of the word “but” ? B-U-T.

“But” means that there is a contradiction, that both phrases cannot be true, the first phrase is limited by the second. An example we might want to consider could be “I want to get ready for work but I’m sleepy”. Something about being sleepy is stopping you from removing the blanket from standing up and getting ready.

Now try replacing the word “but” with the word “and”. “AND” is a more accurate reflection of reality. A-N-D. So for example “I love my partner AND I am angry,” “I want to go out with my friends AND I have pain.”

Can you watch for situations where you often use the word “but” and replace it with the word “and”? This practice can open up more free choice of actions that may be in directions that you want your life to go. You may want to send me some examples in the comment box below.

My Comments

Exercise: Values Clarification [Therapist presented video demonstration and text-based exercise]

[Script] The following table contains 6 areas of life. We want you to give each area a rating, in the second column of between 1 and 10. If you rate it a 1, the area is completely unimportant to you; an area that scores a 10 is extremely important. You needn't prioritise, so you can give each area a 10 if you like.

In the third column, write down some values that matter to you in that area of life. In the fourth column, rate the extent to which you believe you are living according to your values at this moment. If you believe you are living fully in line with your values, enter a 10; if you believe you are completely failing in this respect, write down a 1.

Area of Life	Extent to which this area matters to you	Values	Extent to which you are living according to your values in this area
Family			
Marriage/intimate relationships			
Friends/social life			
Work			
Belief/Spirituality			
Leisure/Recreation			

Now we ask you as a first step, to choose an area of life where you want to live closer to your values. One option is to choose an area that scored highly in terms of importance (2nd column) but lower in terms of living according to your value (4th column).

In what area would you like to live closer to your values? (Type and submit your answer in the box below)

The area I would like to live closer to my values is:

This week you have been working with values. Could you sum up and put into words what you have discovered so far? Is there a particular statement or image that could serve as your motto or watchword? Type this motto down below.

Exercise: My Life's Motto [Text-based exercise]



Metaphor: 80th Birthday [Animation with standard script used in therapist narration]

[Start session with basic breathing mindfulness]

[Continue with standard 80th Birthday script here and include the following]

“Now as you watch your birthday celebrations taking place, in your mind complete the following sentence:

I spent too much time worrying about....(15s)

Now, complete the following sentence:

I spent too little time doing things such as....

And finally in your mind say If I could go back in time, then what I would do differently from today onward would be...

Most people find that this exercise brings up a whole range of feelings, some warm and loving, and some very painful. So take a moment to notice what you're feeling...and consider what these feelings tell you...about what truly matters to you...what sort of person you want to be...and what if, anything, anyone or any situation you're currently neglecting (pause 30s).

[Therapist brings exercise to a close here with basic breathing mindfulness]

Exercise: 80th Birthday [Text-based exercise]

With regards to the 80th birthday exercise that you've just done, I would like you to consider some of the issues below. Type your answers in the box below each question. Now for each of the points the 80 year old you identifies, allow the you of today to make mental notes of your experience during the exercise. Place these notes in the box below:

Were there any thoughts that came to mind as you were completing each sentence?

- 1.
- 2.
- 3.
- 4.
- 5.

What does this tell you about what matters to you, what you want to stand for, and what sort of person you want to be?

How did your mind try to interfere with the exercise?

What feelings showed up for you? Did you make room for them or struggle?

Did you avoid doing the exercise?

If you answered yes to the last question, we would encourage you to try the exercise again. Be open to how the experience of this exercise may benefit you in more ways than one.

Almost there...[Therapist presented video to encourage continued engagement in program]

[Script] We are nearing the end of the program. I hope you've managed to engage in the exercises presented so far and have found them helpful. Naturally, some of the exercises may make more sense than others. Regardless which exercise worked for you, it would be good if you attempted every single one of them to experience the full benefits of this treatment. If there was any part you found difficult, I encourage you to go back to it again and see what turns up for you. Do not be in a rush to reach the end of the program. Remember you can always submit your queries, concerns or difficulties to me in the comment boxes provided. See you in the next session!

Session 2: Committed Action [Therapist presented video]

[Condensed script] Hello. We have come to the final lesson on this program. Well done on having come so far. We have done quite a few exercises together. Some of them have had a greater impact than others, which is natural. Still, we hope you at least found them interesting at the time. You are learning to open up to experiences, which can include getting out of the busy mind, learning to be more aware and connected to the present and all it has to offer, and learning to clarify your goals and values. Living according to your values does not necessarily make life easier – it does however make it more rich, full and satisfying.

You may not completely realise it but you have already done the “engaged” part of our three sets of skills-in fact, just by following the series of sessions and tuning in as you are now! Each time you name a goal, this is a little step of engagement. Also each time you attend one of our online sessions, send an e-mail note, practice a new skill. Each time you encounter a potential barrier and persist this is what we call the “committed action” part of engagement.

Committed action happens in every session. Turning up for therapy, going to see your doctor, practicing the exercises on this program regularly, or engaging in a chosen activity when you have pain is committed action.

Metaphor: The Swamp [Therapist presented video using standard script]

[Text on page] Life includes experiences that are painful. There are choices:

- 1) Choose, run into trouble, quit or
- 2) Choose, run into trouble, and stick to your commitment.

Let's try the following goal setting exercise.

Exercise: Goal Setting [Text-based exercise]

[Text on page] Now we will develop a plan for you to take action according to what is important to you. We are interested in both short term goals or steps and long term goals.

Look over your values work and let's identify relevant high-priority values domains and develop a goal. ***[The acronym of SMART is defined here with simple examples of what is a specific, meaningful, achievable, realistic and time-based goal].***

Participants are asked to

- (a) Write down a goal
- (b) Make a specific action plan
- (c) State the value that will be reflected in pursuing this goal
- (d) Make a public commitment
- (e) Review and plan for barriers to reaching your goal

So if you're willing to, I'd like you to say out loud exactly what it is you're committing to—and as you say it, just notice anything and feelings that arise. Did your mind have anything unhelpful to say? So are you willing to make room for those thoughts and feelings in order to do what matters?

You may choose to write in some of your comments in the box below.

My Comments

Commitments [Therapist presented video]

[Condensed script] Making the changes you have chosen to allow you to live life rather than live pain is not easy. As soon as we have to face any sort of challenge and step out of our comfort zone, our mind will manufacture a whole list of reasons not to do it. I'm not tired. It's too hard. I'll fail. It'll take too long. I don't have enough confidence. I'm too anxious and so on. Your mind, my mind, everybody's mind produces these sorts of thoughts. That's just what minds do. Are you willing to take action, even though your mind can and will give you all sorts of potentially convincing reasons not to do it?

So here's the thing. If you're waiting till the day your pain stops and your mind stops giving you reasons, you'll probably be waiting forever because that's what minds do. They give you reasons not to take action. So just imagine coming back to see me in a year's time and you tell me that nothing has changed in your life...nothing...that the past year has been just more of the same. You've been waiting a year for the day your mind stopped giving reasons...and nothing has changed. Is that the future you truly want?

Building skills to make commitments, do commitments, stick with commitments, or to change them if they are no longer important to you, so that small changes can be built into bigger and longer lasting ones is important. You may be able to identify with the following behaviour patterns that may work against you.

Committed Action [Video with therapist narration]

[Include key points below]

Make a commitment → Break a Commitment

And this is only a short step away from

Make a commitment → Break a Commitment → Quit a Commitment

Or the following:

Make a commitment → Break a Commitment → Quit a Commitment → Feel

Bad about Quitting

Or even:

Make a commitment → Break a Commitment → Quit a Commitment → Feel Bad

about Quitting → Fear Making Commitments → Give Up Making Commitments

If you want to create a different pattern consider the following:

Make a commitment → Break a Commitment → Keep a Commitment

That's you doing committed action! If this is important to you consider making your commitment more real and easier to follow by sharing it with others. Let's put our commitment into action in the next exercise.

Exercise: Willingness and Action Plan (Harris, 2009, pg 221-222)

[Text-based exercise]

Metaphor: The Tour Guide [Video with therapist narration and text-based exercise]

[Text on page] Can you imagine yourself in this situation? What do you do? How as a tour guide are you going to handle your group of difficult tourists?

Type your reactions below.

Tips to practice ACT

Participants are provided with tips to practice ACT [Harris, 2009, p 223. Text on page]

[Text on page] **Tips for Creating Change Around Pain**

The following are some suggestions on how to create change around pain.

10 Suggestions for Creating Change Around Pain

1. Take the time to notice if there is a struggling or fighting quality to the activities you do when pain is present. See if it is possible to let go of that struggling or fighting. If you feel you are playing a tug-or-war with an opponent that you cannot beat, consider dropping the rope.
2. If pain begins to dominate the choices you make, see if it is possible to orient your choices around activities that are important, enjoyable, or meaningful to you. Notice the difference between activities done to “run away” from experiences versus the ones done to have experiences.
3. If you feel that life is filled with things that you “must” do, see if there is a way to include more that you “want” to do.
4. If you begin to worry a great deal and there seems to be no easy solution, consider tuning in to the sensory experiences of what you are doing, such as the sight, sounds, tastes, and other feelings in your body. It is easy and natural sometimes to get wrapped up in the mind, and when you notice this see if you can simply acknowledge it and connect with other experiences in your body and around you at the same time.
5. Notice the mind's ability to constantly travel off to the future or dwell in the past, and, if you feel stuck in some other point in time, bring the focus back to experiences happening in the present when possible.
6. Notice that to some extent pain is a part of life, even if it is an undesirable part. See if your goals can still have meaning if pain and the difficulties it can bring are a part of reaching them.
7. If pain, other feelings you are having, or your mind seems to make you speed up, see if this is truly necessary, see if you can slow down and notice what is going on. Consider, what are the purposes, if any, for all this hurrying?
8. Sometimes pain or uncertainties urge us to stop what we are doing. When this happens, pause, consider slowing down, consider if it is important to keep moving, and keep moving, possibly more slowly.
9. If you find yourself constantly putting things off, waiting to feel better, to feel more certain, or to feel motivated, consider taking action, even a small one. If your mind says this is impossible, consider seeing if you can carry the thought “this is impossible” with you as you take that small step. You can determine the size of the step. And notice, if you are not “stepping,” you are not going anywhere.

10. Ask yourself if your goals can have value and if seeking them can still be done even if this includes discomfort or feels difficult. The answer does not have to be “yes.” If the answer is “no,” possibly look more deeply at your goals and barriers, or consider other goals. If the answer is “yes,” what will you do about it?

Wrapping up the Program and Diary Ratings [Therapist presented video]

[Script] Well, we have come to the end of the program. I hope you have found it interesting and helpful and that you will continue to practice some of these exercises until I next meet you. I will be seeing you in person at your next follow up session where we will review some of your goals and motivations to keep at living a fuller and more satisfying life. As a last exercise, once again, please would you rate the following pain items on a scale of 0-10.

Diary Ratings

[Use same items as Module 1, Session 2]

Optional Mindfulness Exercises:

1. Leaves on the stream exercise [Standard script, audio file]
2. Basic breathing-based mindfulness exercise [Standard script, audio file]
3. Be Where You Are [Standard script, audio file]
4. Brief self-as-observer exercise [Standard script, audio file]
5. Experientially “I’m not that” exercise [Standard script, audio file]

Face- to-Face Session 2

Today's session will focus more on committed action. I am going to start by asking you to do the following:

First, identify a goal that comes to mind. With this goal in mind,

- (a) On a scale from 0-10, how important is it for you to achieve this goal?
(wait for participant's response)
- (b) Why did you not choose a lower number for this goal? (wait for participant's response)
- (c) On a scale from 0-10 how committed are you to taking action to reach your goal? (wait for participant's response)
- (d) What would it take for you to give a commitment score of 9 or 10 to the goal that you have chosen? (wait for participant's response)
- (e) Based on participant's response, the treatment provider will 1) Address a barrier and 2) agree on a plan with the participant.
- (f) Participants are asked to complete the following goals and barriers exercise.

Goals and Barriers

The following exercise is to help you keep moving in a step-by-step fashion toward your goals and to incorporate or prevent the effects of barriers.

Use the following exercise to help you reach any of your current goals.

1. My goal

2. Potential benefits and setbacks

a. Write down one word that reflects an important way in which your life will be better when you achieve your goal

b. Write down one word that reflects a barrier that appears to be standing in the way of you reaching your goal

c. Write down another word that reflects an important way in which your life will be better when you achieve your goal

d. Write down another word that reflects a barrier that appears to be standing in the way of you reaching your goal

3. Say more

First describe in further detail all of the benefits that will come from reaching your goal:

Now consider the barriers that might occur, particularly noticing the difference between barriers that are practical or fixable and those that are more like psychological experiences you are having about your goal, such as anxiety or feeling unsure. List the barriers that are psychological. These can include

thoughts that are discouraging, emotional experiences, such as fear or worries, sensations in your body, such as pain, or others. Simply list and describe these here, labeling each as what it is, a thought, a sensation, an emotion, a memory, and so on. Then list one of your particular skills you will use to accept, defuse, observe, and so on:

Psychological Barriers	Strategy to Address Barriers

Now list the practical or fixable barriers that might occur and describe how you will deal with each:

Practical Barriers	Strategy to Address Barriers

Therapist ends session by summarising the session focus, goals identified, barriers addressed and committed action to maintain treatment progress.

Appendix I. Chapter 11: Participant Invite and Study Information Sheet

You are invited to participate in a research study.

Study Title:

A Feasibility Trial of Acceptance and Commitment Therapy for Chronic Pain in Singapore-Phase 3

Participant Criteria

We are looking for participants who meet the following criteria:

- 1) You are 21 years old and above.
- 2) You have been diagnosed with chronic pain (non-cancer pain) for more than 3 months.
- 3) You are English speaking and can complete an online self report questionnaire without a need for translation.
- 4) You are able to use the internet and e-mails.
- 5) You are not currently participating in a structured approach to Cognitive Behavioural Therapy for chronic pain.
- 6) You are not currently pregnant.
- 7) If you are currently seeing a doctor, you will need your doctor's approval to take part in this study.

Study Information

This study is carried out to (a) develop an adaptation of a treatment called "Acceptance and Commitment Therapy" (ACT) for chronic pain that is suitable for people with chronic pain in Singapore, (b) pilot test elements of treatment delivery and methods for evaluating the treatment, which will be delivered through the internet on a computer. It is important to develop better treatments for people with chronic pain so that people in Singapore will not suffer so much with these conditions and so that they can live and work as they

want to without pain limiting them, and with less need for using medication and seeing doctors.

This study will recruit 30 participants from the pain management clinic at Tan Tock Seng Hospital and via the pain management clinic website over a period of 1 month. About 30 participants will be involved in this study.

What procedures will follow in this study?

You will be asked to participate in a mix of a face-to-face and an online treatment program for chronic pain. The full program will last a span of five weeks with a three month post treatment follow-up. The online treatment program will comprise a total of three modules with two core treatment sessions within each module and five optional exercises delivered over a period of three weeks. The sessions will be organised around three therapeutic modules, comprising psychological skills in areas that we call “openness” a.k.a “accept”, “awareness” a.k.a “connect” and “engage”. You will also be required to attend one face-to-face session with the Principal Investigator (PI) prior to commencing with the online component of the treatment and one face-to-face session after completion of the online program. The treatment content will include a mix of videos, audios, verbal instructions, and information designed to help you make changes to your behaviour and persist with activities that can help you to better reach your goals. These are standard methods from a psychological treatment model known as Acceptance and Commitment Therapy (ACT).

For each and every single lesson, you will first watch an introductory video to the lesson and will engage in a mix of audio or video presented exercises. You will be asked to listen and follow the verbal instructions presented on the audio or video clip. Activities related to these verbal instructions are typically done in a seated position. These activities are not

physical activities and do not require any form of physical exertion. You are also asked to complete text worded assignments which are submitted online. Some of these assignments will be related to the audio or video clip presentation while some are independent but to be completed in relation to the lesson theme itself. Each lesson will take approximately 1hr to complete. You can choose to repeat certain segments within each lesson or the lesson as a whole. There is no limit to the number of times you access each lesson. You should typically complete each module over a 1 week duration.

You will also be asked to complete a set of measures of pain, mood, daily activity, psychological flexibility, basic background, and healthcare usage at pre-treatment, post-treatment and 3 months follow up. There is no treatment intervention at the 3 month follow-up, you are only required to complete a set of questionnaires online. An additional measure of treatment satisfaction and acceptability of treatment will be completed at post-treatment.

Your participation in the study will last a total of 4.5 months including the 3 month follow up period. You will take part in the program for about 5 weeks and be followed up for 3 months after completion of the program. You will need to visit the pain management clinic to see the treatment provider 2 times in the course of the study.

Possible Risks and Side Effects

There are no potential risks or side effects related to your participation in this study. There will be no invasive procedures and you will still undergo treatment as usual with your primary pain specialist. Your answers and responses on the online program and questionnaires have no bearing on any treatment you might already have. They are also kept anonymous only known to the Principal Investigator who is also the treatment provider on the program.

Possible Benefits from Participating in the Study

If you participate in this online treatment program you may reasonably expect to benefit from the program in the following ways: (a) To learn first hand about commonly used self- management methods for chronic pain, (b) to experience what online treatments can be like. You will also help the research team progress with their studies of how to better provide treatments for chronic pain in Singapore. Although the methods being used here are known to provide benefits for people with chronic pain in other studies, we are not able to say for sure whether you will experience the same benefits.

Costs of Study

There are no costs or compensation involved in this study.

Contact Details of Principal Investigator

Before you take part in this research study, the study will be explained to you face-to-face and you will be given the chance to ask questions. Please contact the Principal Investigator via the following contact details should you be interested to take part in this study.

Yang Su-Yin, Pain Management Clinic, Tan Tock Seng Hospital, 11 Jalan Tan Tock Seng, Singapore 308433. Contact Number: +65 9770 3877/6357 8352, e-mail: su_yin_yang@ttsh.com.sg.

Appendix J. Chapter 11: Information Sheet to Health Professionals for Study Recruitment

Dear Doctors and fellow colleagues,

Chronic pain patient volunteers required for Phase 3 study on chronic pain treatment in Singapore.

Circular for use for recruitment of chronic pain patients through the Pain Management Clinic at Tan Tock Seng Hospital for study ref: *2014/00641*, approved by NHG Domain Specific Review Board D (DSRB)-Singapore.

This study is carried out to (a) develop an adaptation of a treatment called “Acceptance and Commitment Therapy” (ACT) for chronic pain that is suitable for people with chronic pain in Singapore, (b) pilot test elements of treatment delivery and methods for evaluating the treatment, which will be delivered through the internet on a computer. It is important to develop better treatments for people with chronic pain so that people in Singapore will not suffer so much with these conditions and so that they can live and work as they want to without pain limiting them, and with less need for using medication and seeing doctors.

This study will recruit 30 participants from the pain management clinic at Tan Tock Seng Hospital and via the pain management clinic website over a period of 1 month. About 30 participants will be involved in this study.

I am writing to invite you to assist in screening for suitable participants for this study. The inclusion and exclusion criteria for participation are indicated in the next section.

Who can take part?

We are looking for patients above the age of 21 years old

1. Diagnosed with chronic nonmalignant pain (non-cancer pain) for more than 3 months.
2. Patients should have an understanding of English at a secondary level and can complete an online self report questionnaire without a need for translation.
3. Patients able to access and use the internet and e-mail.
4. Patients with no previous or current participation in a structured approach to Cognitive Behavioural Therapy for Chronic Pain.
5. Doctor's approval to take part in the study.

Exclusion criteria:

1. Patients with cognitive impairment that will interfere with study participation.
2. Patients with a current mental illness or health problems expected to significantly interfere with study participation.
3. Patients who do not have to capacity to give informed consent.
4. Women patients who are pregnant.

What will happen if patients take part?

Patients will be asked to participate in a mix of a face-to-face and an online treatment program for chronic pain. The full program will last a span of 5 weeks with a 3 month post treatment follow-up. The online treatment program will comprise a total of three modules with two core treatment sessions within each module and five optional exercises delivered over a period of three weeks. The sessions will be organised around three therapeutic modules, comprising psychological skills in areas that we call "openness" a.k.a "accept", "awareness" a.k.a "connect" and "engage". Patients will also be asked to attend one face-to-face session with the Principal Investigator (PI) prior to commencing with the

online component of the treatment and one face-to-face session after completion of the online program. The treatment content will include a mix of videos, audios, verbal instructions, and information designed to help patients make changes to their behaviour and persist with activities that can help them to better reach their goals. These are standard methods from a psychological treatment model known as Acceptance and Commitment Therapy (ACT).

For each and every single lesson, patients will first watch an introductory video to the lesson and will engage in a mix of audio or video presented exercises. They will be asked to listen and follow the verbal instructions presented on the audio or video clip. Activities related to these verbal instructions are typically done in a seated position. These activities are not physical activities and do not require any form of physical exertion. They are also asked to complete text worded assignments which are submitted online. Some of these assignments will be related to the audio or video clip presentation while some are independent but to be completed in relation to the lesson theme itself. Each lesson will take approximately 1hr to complete. Patients are however given 3-4 days to complete each lesson online as they can choose to repeat certain segments within each lesson or the lesson as a whole. There is no limit to the number of times they can access each lesson. Patients will typically complete each module over a 1 week duration.

Patients will also be required to complete a set of measures of pain, mood, daily activity, psychological flexibility, basic background, and healthcare usage at pre-treatment, post-treatment and 3 months follow up. There is no treatment intervention at the 3 month follow-up, patients are only required to complete a set of questionnaires online. An additional measure of treatment

satisfaction and acceptability of treatment will be completed at post-treatment.

These are the measures that patients are required to complete:

1. Pain interference as measured by the Brief Pain Inventory (BPI) interference scale
2. Psychological Flexibility and Experiential avoidance as measured by the Acceptance and Action Questionnaire II (AAQ II)
3. Committed Action as measured by the Committed Action Questionnaire (CAQ)
4. Pain willingness and Activity Engagement as measured by the Chronic Pain Acceptance Questionnaire-8 (CPAQ-8)
5. Pain Intensity as measured by a numerical rating scale (NRS)
6. Depression measured by the Patient Health Questionnaire-9 (PHQ-9)
7. Satisfaction with life as measured by the Satisfaction with Life Scale (SWLS)
8. Demographics
9. Healthcare usage
10. A survey on treatment satisfaction and effectiveness (immediately post-treatment at the end of the program)

Patients' participation in the study will last a total of 4.5 months including the 3 month follow up period. They will take part in the program for about 5 weeks and be followed up for 3 months after completion of the program. They will need to visit the pain management clinic to see me for the face-to-face treatment 2 times in the course of the study.

The treatment will not interfere with patient's current standard treatment at the Pain Management Clinic. Participation in the research is purely voluntary.

There will be no cost borne by the patient during the course of the treatment trial.

When will recruitment take place?

Recruitment will take place between **1st October 2014** to **31th January 2015** at the Pain Management Clinic and via the Pain Management Clinic website.

Contact Details

Thank you for taking the time to read this research invitation. If you would like more information, please contact me (Ms Yang Su-Yin) via e-mail: su_yin_yang@ttsh.com.sg or phone: 9770 3877.

Appendix K. Chapter 11: Participant Informed Consent Form

INFORMED CONSENT FORM

1. Study Information

Protocol Title:

A Feasibility Trial of Acceptance and Commitment Therapy for Chronic Pain in Singapore-Phase 3

Principal Investigator & Contact Details:

Yang Su-Yin, Senior Psychologist, Pain Management Clinic, Tan Tock Seng Hospital, 11 Jalan Tan Tock Seng, Singapore 308433. Contact Number: +65 9770 3877(HP)/ +65-6357 8352 (Clinic).

2. Purpose of the Research Study

You are invited to participate in a research study. It is important to us that you first take time to read through and understand the information provided in this sheet. Nevertheless, before you take part in this research study, the study will be explained to you and you will be given the chance to ask questions. After you are properly satisfied that you understand this study, and that you wish to take part in the study, you must sign this informed consent form. You will be given a copy of this consent form to take home with you.

You are invited because you have been diagnosed with chronic (non-malignant) pain and have been assessed to have difficulty with your normal daily activities related to your pain condition by a health professional treating you.

This study is carried out to (a) develop an adaptation of a treatment called “Acceptance and Commitment Therapy” (ACT) for chronic pain that is suitable for people with chronic pain in Singapore, (b) pilot test elements of treatment delivery and methods for evaluating the treatment, which will be delivered through the internet on a computer. It is important to develop better treatments for people with chronic pain so that people in Singapore will not suffer so much with these conditions and so that they can live and work as they want to without pain limiting them, and with less need for using medication and seeing doctors.

This study will recruit 30 subjects from the pain management clinic at Tan Tock Seng Hospital and via the pain management clinic website over a period of 1 month. About 30 subjects will be involved in this study.

3. What procedures will be followed in this study

Prior to giving informed consent today, you would have been screened by your attending primary pain physician or health professional (pain nurse, physiotherapist, occupational therapist or pain psychologist) at the pain clinic for eligibility to participate. Your primary pain physician would also have given approval for you to take part in this study.

If you take part in this study, you will be given a unique username and password to log on to the online program as well as have access to an e-mail account built within the system. Upon login, you will be directed to a webpage inviting you to complete a set of questionnaires. These are the measures that you are required to complete:

1. Pain interference as measured by the Brief Pain Inventory (BPI) interference scale
2. Psychological Flexibility and Experiential avoidance as measured by the Acceptance and Action Questionnaire II (AAQ II)
3. Committed Action as measured by the Committed Action Questionnaire (CAQ)
4. Pain willingness and Activity Engagement as measured by the Chronic Pain Acceptance Questionnaire-8 (CPAQ-8)
5. Pain Intensity as measured by a numerical rating scale (NRS)
6. Depression measured by the Patient Health Questionnaire-9 (PHQ-9)
7. Satisfaction with life as measured by the Satisfaction with Life Scale (SWLS)
8. Demographics
9. Healthcare usage
10. A survey on treatment satisfaction and effectiveness (immediately post-treatment at the end of the program)

Except for the general demographic measure, you will be asked to complete these same measures at post-treatment and 3 months follow-up. An additional measure of treatment satisfaction and effectiveness of treatment will be assessed at post treatment.

Face-to-face session

Upon completion of the set of pre-treatment measures, you will be sent an e-mail to schedule for a face-to-face session with the Principal Investigator (PI) before proceeding with the online treatment program. The face-to-face session will comprise of a verbal demonstration of "The Chinese Finger Trap" exercise, and you are also asked to complete a pen and paper goal setting form as part of this session. The second face-to-face session at the end of the online program, will comprise of a verbally delivered 'motivational interviewing' exercise and you are also asked to complete a pen and paper assignment on goal setting and barriers. The face-to-face sessions are delivered as it would be in a standard psychological treatment session. The face-to-face sessions at the start of the online program and at the end of the program are scheduled to last up to 45mins each, which is the standard treatment time for a psychology consultation.

Online sessions

Following the face-to-face session, you will receive an automated e-mail with an embedded link to direct you to the first treatment session on the online program. You will need to complete a total of 3 modules. Each module will be comprised of two key lessons to be completed in a stage-by-stage basis. Prior to starting the first lesson, you will watch an introductory video that provides a brief explanation of the online program. You will then proceed to start module 1 which is labelled as 'Accept'. Within the accept module are two lessons. The first lesson is titled 'Why I avoid' and lesson two titled 'You are not your thoughts'. Module two is labelled 'Connect', lesson one in this module is titled 'Acceptance including Thoughts' and lesson two is titled 'In the present moment'. Module three is labelled as 'Engage', Lesson one in this module is

titled 'What do you want out of life?' and lesson two is titled ' I am committed to live'.

For each and every single lesson, you first watch an introductory video to the lesson and will engage in a mix of audio or video presented exercises. You will be asked to listen and follow the verbal instructions presented on the audio or video clip. Activities related to these verbal instructions are typically done in a seated position. These activities are not physical activities and do not require any form of physical exertion. You are also asked to complete text worded assignments which are submitted online. Some of these assignments will be related to the audio or video clip presentation while some are independent but to be completed in relation to the lesson theme itself. Each lesson will take approximately 1hr to complete. You are however given 3-4 days to complete each lesson online as you can choose to repeat certain segments within each lesson or the lesson as a whole. There is no limit to the number of times you access each lesson. You will complete each module over a 1 week duration. The PI will grant you access to the next lesson once the current lesson is completed. You will typically be able to access the first lesson of each module on a Monday and the second session of each module on a Thursday. You can also choose to access 5 optional exercises at any point during the program. All 5 optional exercises will either be presented in audio or video format. Similar to the audio and video clips you will see in the main lessons, you will only need to listen and follow the verbal instructions presented. There are no submitted assignments for the optional exercises. An automated e-mail response will be sent to you upon login and completion of each lesson. The e-mail will contain information about the next lesson and an embedded link for you to directly access the lesson page.

Once per week, at the end of lesson 2 of every module, you are asked to complete a set of online questions on a rating scale of 0-10 (0=not at all, 10=completely). You will rate the following on a scale of 0-10: 1) How much did you struggle with pain this week? 2) How much did you open up to pain and distress, and simply allow them to be there? 3) To what extent were you "living in the present" rather than focusing on your own thoughts, the past or future? 4) How often did you follow your values and goals? Answers to these questions are helpful for you and the PI to track your progress.

A comment box also is made available at the end of every session. You are encouraged to write your comments or questions about each session in the comment box. The PI will answer all received comments within 24 hours via e-mail.

Upon completion of the online program, you will be sent an e-mail link inviting you to complete the post treatment questionnaires online. You will be alerted via e-mail to complete the outcome measures at 3 months follow-up.

Your participation in the study will last a total of 4.5 months including the 3 month follow up period You will take part in the program for about 5 weeks (online program and 2 face-to-face sessions) and be followed up for 3 months after completion of the program. You will need to visit the pain management clinic to see the PI two times in the course of the study.

If you agree to take part in this study, the following will happen to you:

You will be given a unique username and password that will allow you to access the online program webpage and an e-mail account on the program system. Upon login to the program, you will be directed to a webpage inviting you to complete the standard set of measures mentioned above. Upon completion of the set of pre-treatment measures, you will be scheduled for a face-to-face session with the PI before proceeding with the online treatment program. Following the face-to-face session, you will receive an automated e-mail with an embedded link to direct you to the first treatment session on the online program. You will complete each module of 2 lessons

each online within a 1 week duration. You will then be scheduled to see the PI for a final face-to-face session after the completion of the 3 week online program.

Once per week, after completion of the last lesson on each module you are asked to complete a set of four short questions on a rating scale of 0-10 (0=not at all, 10=completely). These questions will keep track of changes in the skills you are learning within the treatment exercises, including how open you are, how aware of your own experiences, and how much you are focused on your goals.

A comment box also is made available at the end of every session. You are encouraged to write your comments or questions about each session in the comment box. The person providing the treatment will answer all received queries within 24 hours via email.

After completing the online treatment, you will be asked to complete a set of post treatment questionnaires online. An e-mail link will be sent to you at the 3 month follow up period to ask you to complete a set of follow up questionnaires online. This questionnaire also includes the set of questionnaires stated above. The following study schedule summaries your involvement in the study.

When your participation in the study ends, you will no longer have access to the online program, unless special additional arrangements are made by the treatment provider. The table below shows you the schedule and requirements needed of you each week over the 5 weeks of study participation.

Week 0	Week 1	Week 2	Week 3	Week 4	Week 5	3-months post-treatment
<p>Upon approval by participants' primary physician, participants are scheduled to meet the PI/treatment provider to clarify questions about the study.</p> <p>Informed Consent to be taken.</p> <p>Participants complete pre-treatment questions online once consent given</p>	<p>Meet PI/treatment provider for first face-to-face session after completion of questionnaires.</p>	<p>Monday-Thursday</p> <p>Participants have access to the online program and complete the first lesson on module 1 (Accept) of the online program.</p> <p>Thurs- Complete 2nd lesson on module 1</p> <p>Complete 0-5 ratings for 5 questions online</p> <p>At the start of week 2 through to end of week 4, participants can choose to access any of the 6 optional exercises online.</p>	<p>Monday-Thursday</p> <p>Access and complete 1st lesson on 2nd module (Connect) of online program.</p> <p>Thurs- Access and complete 2nd lesson on 2nd module of online program</p> <p>Complete 0-5 ratings for 5 questions online</p>	<p>Monday-Thursday</p> <p>Participants access and complete 1st lesson on 3rd module (Engage) of the online program.</p> <p>Thurs- Assess and complete 2nd lesson on 3rd module of online program.</p> <p>Complete 0-5 ratings for 5 questions online</p> <p>Complete a set of post-treatment questionnaires including treatment satisfaction ratings upon completion of program.</p>	<p>Meet PI/treatment provider for 2nd and final face-to-face session.</p>	<p>Complete a set of treatment follow-up questionnaires online</p>

4. Your Responsibilities in This Study

If you agree to participate in this study, you should follow the advice given to you by the study team. You should be prepared to visit the hospital 2 times and undergo all the procedures that are outlined above.

5. What Is Not Standard Care or is Experimental in This Study

The study is being conducted because online treatment programs like the one being used here are widely used and known to be helpful in many other countries in the world but are not yet investigated or available in Singapore. General treatments that are similar to this one but delivered only face-to-face are actually available in Singapore, but are not widely used. So, the current study includes some currently available methods but is investigating ways to deliver them that are new not just within Singapore but within South East Asia. We hope that your participation will help us to

determine whether the online program is equal or superior to existing psychological treatments available for chronic pain management.

Although psychological treatment may be part of standard medical care, and could be available to you otherwise if you wished it, in this study the online delivery system and the careful evaluation procedures are only being performed for the purposes of the research, and are not part of your routine care.

6. Possible Risks and Side Effects

There are no potential risks or side effects related to your participation in this study. There will be no invasive procedures and you will still undergo treatment as usual with your primary pain specialist. Your answers and responses on the online program and questionnaires have no bearing on your treatment at the pain management clinic. They are also kept anonymous only known to the PI who is also the treatment provider on the program. The study will not carry any physical risks as they are no activities that require any physical activity on the part of the participant during study participation. Although a majority of the sessions will be done online without any site supervision, the program is placed on a secure site and is also password secured. Your identities are kept anonymous on the program. There is a two way interactive portal that is built in to the system as well where the PI can check how you are managing each lesson and likewise you are able to interact via e-mail with the PI through this portal.

7. Possible Benefits from Participating in the Study

If you participate in this online treatment program you may reasonably expect to benefit from the program in the following ways: (a) To learn first-hand about commonly used self- management methods for chronic pain, (b) to experience what online treatments can be like. You will also help the research team progress with their studies of how to better provide treatments for chronic pain in Singapore. Although the methods being used here are known to provide benefits for people with chronic pain in other studies, we are not able to say for sure whether you will experience the same benefits.

8. Important Information for Women Subjects

Pregnant women are not recruited for this study.

The effect of an internet-based intervention on a baby's development is not known. Therefore, pregnant and breast-feeding women may not take part in this study. If you become pregnant during this study, please call your doctor or the Principal Investigator immediately.

9. Alternatives to Participation

If you choose not to take part in this study, all of your healthcare and subsequent experience of your chronic pain will be unaffected. You will receive whatever is your standard care for your condition. In our institution this would be determined by you and your doctors. If you do not wish to take part in the study it will have no bearing on your other treatments in any way.

Current standard treatments for chronic pain can include medications, physiotherapy, procedures that include injections, or operations (appropriate for very few people). Medications are by far the most common treatment for chronic pain, other than doing nothing. We are not able to determine whether your doctor will recommend any of these for you. Some of these treatments can partially reduce pain. Most of the time they are not completely effective or the benefits are not permanent. You should talk to

your doctor to understand the options and expected outcomes in your individual case.

All of medical, rehabilitation, or surgical treatments can cause side effects, from mild to moderate unpleasant physical symptoms, increased pain, infection, or the need for repeated procedures. Again, you would speak to your doctor about the details in your own cases

10. Costs & Payments if Participating in the Study

There are no costs and payments involved in participating in this study.

11. Voluntary Participation

Your participation in this study is voluntary. You may stop participating in this study at any time. Your decision not to take part in this study or to stop your participation will not affect your medical care or any benefits to which you are entitled. If you decide to stop taking part in this study, you should tell the Principal Investigator.

If you withdraw from the study, you will be required to let the Principal Investigator know. There is no other action needed on your part.

However, the data that have been collected until the time of your withdrawal will be kept and analysed. The reason is to enable a complete and comprehensive evaluation of the study.

Your doctor, the Investigator and/or the Sponsor of this study may stop your participation in the study at any time if they decide that it is in your best interests. They may also do this if you do not follow instructions required to complete the study adequately. If you have other medical problems or side effects, a doctor and/or nurse will decide if you may continue in the research study.

In the event of any new information becoming available that may be relevant to your willingness to continue in this study, you (*or your legally acceptable representative, if relevant*) will be informed in a timely manner by the Principal Investigator or his/her representative.

12. Compensation for Injury

If you follow the directions of the researchers or treatment providers in charge of this study and you are physically injured due to the trial procedures given under the plan for this study, Tan Tock Seng Hospital will pay the medical expenses for the treatment of that injury.

Payment for management of the normally expected consequences of your treatment will not be provided by *Tan Tock Seng Hospital*.

Tan Tock Seng Hospital without legal commitment will compensate you for the injuries arising from your participation in the study without you having to prove Tan Tock Seng Hospital is at fault. There are however conditions and limitations to the extent of compensation provided. You may wish to discuss this with your Principal Investigator.

By signing this consent form, you will not waive any of your legal rights or release the parties involved in this study from liability for negligence.

13. Confidentiality of Study and Medical Records

Information collected for this study will be kept confidential. Your records, to the extent of the applicable laws and regulations, will not be made publicly available.

However, the NHG Domain-Specific Review Board and Ministry of Health will be

granted direct access to your original medical records to check study procedures and data, without making any of your information public. By signing the Informed Consent Form attached, you (*or your legally acceptable representative, if relevant*) are authorizing (i) collection, access to, use and storage of your “Personal Data, and (ii) disclosure to authorised service providers and relevant third parties.

“Personal Data” means data about you which makes you identifiable (i) from such data or (ii) from that data and other information which an organisation has or likely to have access. This includes medical conditions, medications, investigations and treatment history.

Research arising in the future, based on this Personal Data, will be subject to review by the relevant institutional review board.

By participating in this research study, you are confirming that you have read, understood and consent to the Personal Data Protection Notification available at <http://www.ttsh.com.sg/patient-guide/page.aspx?id=4468>

Data collected and entered into the Case Report Forms are the property of Tan Tock Seng Hospital. In the event of any publication regarding this study, your identity will remain confidential.

14. Who To Contact if You Have Questions

If you have questions about this research study, you may contact the Principal Investigator, Yang Su-Yin, Senior Psychologist, Pain Management Clinic, Tan Tock Seng Hospital, 11 Jalan Tan Tock Seng, Singapore 308433. Contact Number: +65 9770 3877(HP)/ +65-6357 8352 (Clinic).

In case of any injuries during the course of this study, you may contact the Principal Investigator, Yang Su-Yin, Senior Psychologist, Pain Management Clinic, Tan Tock Seng Hospital, 11 Jalan Tan Tock Seng, Singapore 308433. Contact Number: +65 9770 3877(HP)/ +65-6357 8352 (Clinic).

The study has been reviewed by the NHG Domain Specific Review Board (the central ethics committee) for ethics approval.

If you want an independent opinion to discuss problems and questions, obtain information and offer inputs on your rights as a research subject, you may contact the NHG Domain Specific Review Board Secretariat at 6471-3266. You can also find more information about the NHG Domain Specific Review Board at www.research.nhg.com.sg.

If you have any complaints or feedback about this research study, you may contact the Principal Investigator or the NHG Domain Specific Review Board Secretariat.

CONSENT FORM

Protocol Title:

A Feasibility Trial of Acceptance and Commitment Therapy for Chronic Pain in Singapore-Phase 3

Principal Investigator & Contact Details:

Yang Su-Yin, *Pain Management Clinic, Tan Tock Seng Hospital, 11 Jalan Tan Tock Seng, Singapore 308433, Tel: 6357 8352 (0), e-mail: su_yin_yang@ttsh.com.sg.*

I voluntarily consent to take part in this research study. I have fully discussed and understood the purpose and procedures of this study. This study has been explained to me in a language that I understand. I have been given enough time to ask any questions that I have about the study, and all my questions have been answered to my satisfaction.

Name of Participant

Signature

Date

Witness Statement

I, the undersigned, certify to the best of my knowledge that the participant signing this informed consent form had the study fully explained in a language understood by him / her and clearly understands the nature, risks and benefits of his / her participation in the study.

Name of Witness

Signature

Date

Investigator Statement

I, the undersigned, certify that I explained the study to the participant and to the best of my knowledge the participant signing this informed consent form clearly understands the nature, risks and benefits of her participation in the study.

Name of Investigator /
Person administering consent

Signature

Date

Appendix L. Chapter 11: Items Measuring Pre- and Post-treatment Expectations

Pre-treatment Expectations

1. Do you expect that this treatment program will help you to manage your pain better?

1	2	3	4	5
Not at all	A little	Reasonably	Strongly	Very strongly

2. How successful do you think this treatment will be in reducing your limitations due to pain?

1	2	3	4	5
Extremely unsuccessful	Unsuccessful	Neither successful nor unsuccessful	Successful	Extremely successful

3. By the end of treatment, how much improvements in your limitations due to pain do you feel will occur?

0%	10%	20%	30%	40%	50%	60%	70%	80%	90%	100%
----	-----	-----	-----	-----	-----	-----	-----	-----	-----	------

Post-treatment Expectations

1. Were your expectations of the treatment program met?

1	2	3	4	5
Highly unmet	Unmet	Neither met nor unmet	Met	Highly met

2. How successful was the treatment in reducing your limitations due to pain?

1	2	3	4	5
Extremely unsuccessful	Unsuccessful	Neither successful nor unsuccessful	Successful	Extremely successful

3. How much improvements in your limitations due to pain have occurred?

0%	10%	20%	30%	40%	50%	60%	70%	80%	90%	100%
----	-----	-----	-----	-----	-----	-----	-----	-----	-----	------

Appendix M. Chapter 11: Survey on Program Acceptability and Treatment Satisfaction

Survey

1. We would like your opinion on the following aspects of the iACT-CEL program. Please rate your answers on a scale of 1 to 5 where “1” represents “strongly disagree” and “5” represents “strongly agree”.

a) I found the information on the program easy to understand

1 Strongly disagree	2 Disagree	3 Neither agree nor disagree	4 Agree	5 Strongly agree
------------------------	---------------	---------------------------------	------------	---------------------

b) I found the information to be personally relevant

1 Strongly disagree	2 Disagree	3 Neither agree nor disagree	4 Agree	5 Strongly agree
------------------------	---------------	---------------------------------	------------	---------------------

c) I found the program easy to use

1 Strongly disagree	2 Disagree	3 Neither agree nor disagree	4 Agree	5 Strongly agree
------------------------	---------------	---------------------------------	------------	---------------------

d) I found the interactive exercises helpful

1 Strongly disagree	2 Disagree	3 Neither agree nor disagree	4 Agree	5 Strongly agree
------------------------	---------------	---------------------------------	------------	---------------------

e) The ability to communicate with the therapist via e-mail was important to me

1 Strongly disagree	2 Disagree	3 Neither agree nor disagree	4 Agree	5 Strongly agree
------------------------	---------------	---------------------------------	------------	---------------------

f) I am able to apply the techniques learnt on the program in my daily life

1 Strongly disagree	2 Disagree	3 Neither agree nor disagree	4 Agree	5 Strongly agree
------------------------	---------------	---------------------------------	------------	---------------------

g) The duration of the program was just right

1 Strongly disagree	2 Disagree	3 Neither agree nor disagree	4 Agree	5 Strongly agree
------------------------	---------------	---------------------------------	------------	---------------------

h) The iACT-CEL program is likely to help people with chronic pain manage pain more effectively.

1 Strongly disagree	2 Disagree	3 Neither agree nor disagree	4 Agree	5 Strongly agree
------------------------	---------------	---------------------------------	------------	---------------------

How satisfied were you with the iACT-CEL program? Please rate your satisfaction of each item on a scale of 1 to 5 where "1" represents "extremely unsatisfied" and "5" represents "extremely satisfied".

a) How satisfied are you with the response time of the therapist on the program?

1 Extremely unsatisfied	2 Unsatisfied	3 Neither satisfied nor unsatisfied	4 Satisfied	5 Extremely satisfied
----------------------------	------------------	--	----------------	--------------------------

b) How satisfied are you with the quality of the interaction with the therapist on the program?

1 Extremely unsatisfied	2 Unsatisfied	3 Neither satisfied nor unsatisfied	4 Satisfied	5 Extremely satisfied
----------------------------	------------------	--	----------------	--------------------------

c) How satisfied are you with the iACT-CEL online program?

1 Extremely unsatisfied	2 Unsatisfied	3 Neither satisfied nor unsatisfied	4 Satisfied	5 Extremely satisfied
----------------------------	------------------	--	----------------	--------------------------

d) How satisfied are you with the total treatment (including the face-to-face sessions)?

1 Extremely unsatisfied	2 Unsatisfied	3 Neither satisfied nor unsatisfied	4 Satisfied	5 Extremely satisfied
----------------------------	------------------	--	----------------	--------------------------

Satisfaction With Life Scale (SWLS)

Below are five statements that you may agree or disagree with. Using the 1-7 scale below, indicate your agreement with each item by placing the appropriate number on the line preceding that item. Please be open and honest in your responding.

- 1 = strongly agree
- 2 = disagree
- 3 = slightly disagree
- 4 = neither agree nor disagree
- 5 = slightly agree
- 6 = agree
- 7 = strongly agree

- ____ 1. In most ways my life is close to my ideal.
- ____ 2. The conditions of my life are excellent.
- ____ 3. I am satisfied with my life.
- ____ 4. So far I have gotten the important things I want in life.
- ____ 5. If I could live my life over. I would change almost nothing.

Satisfaction with Life Scale (SWLS), 1985. Diener, E., Emmons, R.A., Larsen, R.J., & Griffin, S. (1985). The satisfaction with life scale. *Journal of Personality Assessment*, 49, 71-75. This scale is in the public domain.

Other Publications

Yang, S.Y., & McCracken, L.M. (2014). Acceptance and Commitment Therapy for chronic pain. *JCOM*, 21(3), 134-144. (Included with permission by Turner White Communications)

Acceptance and Commitment Therapy for Chronic Pain

Case Study and Commentary, *Su-Yin Yang, MSc, and Lance M. McCracken, PhD*

ABSTRACT

- **Objective:** To describe Acceptance and Commitment Therapy (ACT) and its application in the treatment of chronic pain.
- **Methods:** Review of the theoretical and clinical literature and presentation of a case example.
- **Results:** General cognitive behavioral approaches for chronic pain have a consistent and large evidence base supporting their benefits. Even so, these treatments continue to develop with the aim to improve. One example of a relatively new development within the cognitive behavioral approaches is ACT, a treatment that focuses on increasing psychological flexibility. Here we describe ACT and the therapeutic model on which it is based, present its distinguishing features, and summarize the evidence for it as a treatment for chronic pain. We also discuss such issues as dissemination, implementation, and training.
- **Conclusion:** There are now 7 randomized controlled trials, a number of innovative uncontrolled trials, and at least 1 systematic review that support the clinical efficacy and effectiveness of ACT for chronic pain. Further research and development of this approach is underway.

The introduction of the gate control theory of pain [1] in 1965, among other events, signaled a shift in our understanding of pain, particularly chronic pain. This shift, which continues today, is a shift from a predominantly biomedical model of chronic pain to a biopsychosocial model. This model, as the name suggests, includes psychosocial influences in a key role in relation to the experience of pain and the impact of this experience. During this same period of time, psychosocial models and treatment methods have also shifted and evolved. This evolution has included the operant approach [2], the cognitive behavioral approach [3], and the latest developments, contextual cognitive behavioral approaches [4,5], among

which Acceptance and Commitment Therapy (ACT) and mindfulness-based therapies are key examples.

Until about 10 years ago, the mainstream of psychological treatments for chronic pain and other physical health problems was dominated almost exclusively by concepts and methods of what we will refer to as “traditional” cognitive behavioral therapy (CBT). Specific constructs within what is called the “common sense model” [6], such as illness perceptions, beliefs about control over one’s illness, amongst other constructs such as self-efficacy, catastrophising, fear avoidance, and pain-related anxiety, captured a substantial focus of research and treatment development during most of the past 3 decades [7]. The treatment methods that have emerged and persisted from this work have included relaxation, attention-based and cognitive coping strategies, cognitive restructuring, the use of imagery, and certain activity management strategies [8]. However, despite consistent supportive evidence for CBT interventions for chronic pain [9], there remain gaps and areas of relative weakness, both in the conceptual models underlying this work and in the base of evidence. Research clearly shows that not all patients benefit from traditional CBT interventions, and recent reviews of CBT for chronic pain generally show effect sizes that are usually small or medium at best [9–11].

The Problem with Pain

Pain hurts and is often viewed as harmful, and this leads to fear or anxiety, avoidance, or attempts to control the pain. Seeking to control pain is entirely natural and even seems necessary to reduce the undesirable effects of pain in one’s life.

Dependent on the situation, pain avoidance, sometimes also referred to as “fear avoidance,” in studies of

From the Health Psychology Section, Institute of Psychiatry, King’s College, London.

chronic pain can present itself in many forms. Avoidance behavior can include refusal to engage in any activity believed to cause an increase in pain. It may also include “guarding” or bracing around an area of pain, information seeking, treatment seeking, taking medications, overdosing on medications, using aids like heat or ice, withdrawing from social activity, as well as being unwilling to talk about emotional experiences, amongst others [5]. Today, avoidance is recognized as a key foundation element in pain-related suffering and disability [12], and addressing it effectively has become a prime focus in many or most current treatments.

Acceptance and Psychological Flexibility

In recent years, the concept of “acceptance” has gained prominence as a potentially important process for addressing a broad array of psychological problems, including those associated with chronic pain. From this new interest, a fundamentally different treatment emphasis has emerged. This includes a shift away from a predominant focus on changing thoughts and feelings, a focus sometimes adopted within some traditional CBT methods, towards a focus on reducing the influence of thoughts and feelings on our actions instead. This can be a rather confusing distinction. This is because the influence of our thoughts and feelings is often automatic and even invisible to us as it occurs. As such, the influences of our thoughts and feelings appear directly tied to the content of thoughts and feelings, but the matter is not that simple. Clearly there are occasions when our actions contradict our thoughts and feelings, such as when we have perfectly confident beliefs and fail, or significant anxiety and perform successfully. Such instances illustrate what we might call a “2-dimensional” quality of experience; it is the content of experience and the context of experience that determine the influence exerted. Suffice it to say acceptance-based methods are designed to address the difference between experiences that are difficult to control, such as thoughts and feelings, and things that are easier to control: the actions we take in relation to our thoughts and feelings. They do this by taking a focus on creating changes in context and ultimately in behavior. Acceptance includes especially a focus on allowing or opening up to feelings rather than struggling with them or retreating from them. Here, the capacity for openness is a contextual process.

Acceptance methods are not used in isolation. They are usually used in combination with other traditional

behavior change strategies, with methods to facilitate values clarification, committed action, and other methods from ACT. Notions of acceptance have even been incorporated into many behavioral and cognitive therapies before, including dialectical behavior therapy [13] and mindfulness-based treatment [14,15], and so this process is not the exclusive domain of ACT. In implementing acceptance-based methods, patients are taught skills, such as to (a) notice feelings specifically in detail, (b) notice that thoughts about pain are products of thinking and not the same as direct experience, (c) notice urges to struggle with thoughts and feelings, (d) to practice refraining from struggling and adopt an observing, allowing, and “making room”-type posture, and (e) take action in line with their goals [4,5].

The wider processes around acceptance in combination are referred to as psychological flexibility [16]. Psychological flexibility relates to one’s ability to directly contact the present moment; to be aware of the thoughts, feelings and potentially unwanted internal experiences it brings; and to follow through with a behavior change or persist with a chosen behavior in the direction of chosen values. Psychological flexibility is the model for psychological health from an ACT perspective [17].

Psychological Flexibility and the 6 Core ACT Processes

At least some of the core processes of ACT have been mentioned already. They are unusual enough for most readers so that a more careful definition of each can be useful. At the core of ACT is the concept of psychological flexibility. Again, psychological flexibility is one’s ability to effectively respond and make behavior changes according to one’s personal goals and values while potentially interfering thoughts and feelings are occurring, and without being blocked by those thoughts and feelings [18]. Psychological flexibility is enhanced through a focus on 6 core ACT processes, namely Acceptance, Cognitive Defusion, Present Moment Awareness, Self as Context, Values, and Committed Action [4], in no particular order. The interrelations between these processes are depicted in **Figure 1**.

Acceptance

Acceptance involves the patients’ willingness to have pain while remaining able to actively choose to continue participating in their life as they want it to be. ACT encourages patients to act in ways that are consistent with direct

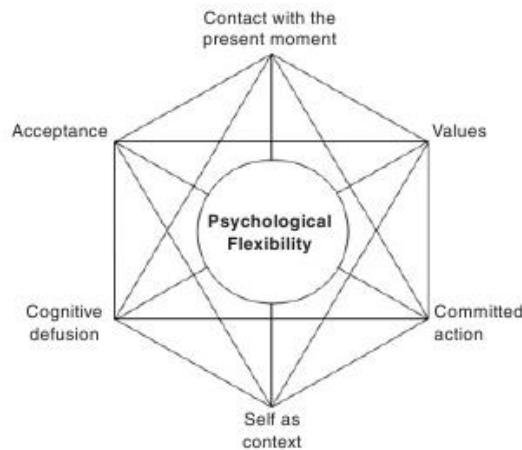

Figure 1. An ACT model.

experiences rather than what the mind interprets these events to mean.

Cognitive Defusion

Cognitive defusion is the process of modifying one’s reaction to thoughts by constructing contexts where the influences of these thoughts on behavior are lessened [18]. Unlike traditional cognitive behavior approaches, in ACT it is not the content and actual validity of these thoughts that is challenged but the functions, or influences, of thoughts [19].

Present Moment Awareness

Contact with the present moment reflects the process wherein the person is aware of the situation in “the now” as opposed to focusing on events that happened in the past or might happen in the future [18]. To be “present” requires the individual to flexibly focus attention on experiences as they are happening in the environment, in real time, and to be fully open to what is taking place [20]. It is important the individual is able to notice when he or she is not acting in relation to the present moment and has the ability to shift attention to the present if this shift benefits them.

Self as Context

The sense of self-as-context or self-as-observer is considered the ability to adopt a perspective or point of view that is separate from and not defined by thoughts

and feelings or even the physical body. This contrasts a sense of self as made up of personality characteristics, self-evaluations, or a narrative about who we are [5,16]. In ACT, perspective taking can be trained to help people connect with the experience of a distinction between self and psychological experiences. From this, one can choose to follow one’s inner verbal constructions of what defines us, our “stories” of who we are, in certain situations when it works to do so, and not in situations where it leads to unhealthy responses and behavioral restriction.

Values

Values are defined as guiding principles in one’s life. Values are often contrasted with goals, where the difference is that goals can be achieved while values are part of an ongoing process of action and cannot be completed once and for all. In a sense, goals represent set plans of action to be achieved while values are general life directions. If life is like a journey, then goals would be the chosen destination and values would simply be represented by a general direction of travel. Values are helpful when patients struggle with unwanted internal experiences like pain, as they not only serve as a guide for the client to persist in behavior change but also function as a motivating element. Values clarification exercise in therapy encourages the patient to define their values in specific domains of “career, family, intimate relationships, friendships, health, education and spirituality” [4,21] regardless of the primary problem. Personally chosen and clarified values can function as guides when people have difficulty initiating and maintaining behavior change in the presence of unwanted internal experiences.

Committed Action

Committed action is an ongoing process of redirecting behavior in order to create patterns of flexible and effective action in line with a defined value [22]. Patients are encouraged to follow through with their chosen actions that are in line with their values, and to persist or alter their course flexibly. Without the capacity for committed action, behavior change is less likely to persist and integrate into patterns of behavior more generally.

The 6 core processes of ACT in combination are designed to serve the purpose of better functioning. They are the focus of ACT methods but not an end in themselves. This “process” and “outcome” distinction is an important one in ACT. The main focus of ACT is to enhance activity and function through an increase

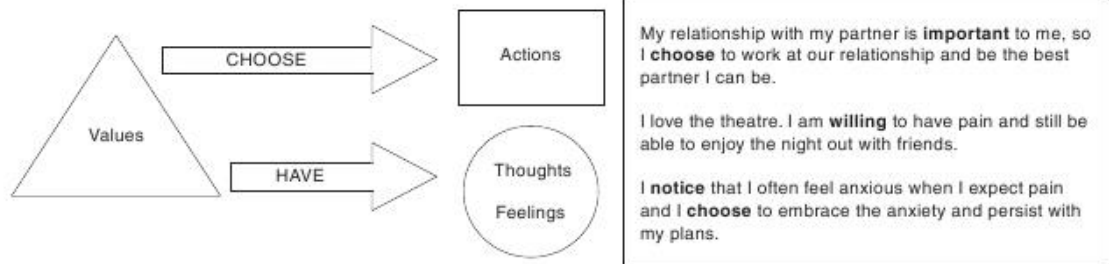



Figure 2. ACT response. (Modified with permission from Dr Paul M Guinther, Portland Psychotherapy, http://contextualscience.org/post/handout_on_cbtbaact).

in psychological flexibility. Unlike many psychological therapies, ACT does not aim for symptom reduction as a primary therapeutic goal. **Figure 2** pictorially depicts psychologically flexible behavior.

CASE STUDY

Initial Presentation and History

 Ms X, a 45-year-old woman, presents with the chief complaint of low back pain, which she has experienced for 3 years. She works part-time due to her pain problem. When she is not at work, she busies herself with seeking both conventional and alternative treatments for her pain condition. In the past, during periods where she experienced pain relief, she attempted to engage in her hobby of photography. However, this often led to a pain flare the next day and required 2 to 3 days of medical leave with increased medication from her PCP before she is able to return to work. As a result, Ms X chose to give up her hobby and focus on treating her pain instead. Ms X is in a constant struggle with her pain condition and believes that she can only return to photography, and live a more normal life, after her pain is cured.

• **What are considerations for applying ACT in this scenario?**

From an ACT conceptualization this case shows patterns of avoidance that are apparently not helping the person to reach her goals but are causing her distress and restrictions in functioning. An ACT therapist would approach this scenario by first reflecting how normal it is to struggle with pain and stop activities when in pain. From there

they might (a) identify what the patient wants from treatment, (b) look at what has been done so far to attain this, (c) examine how well those things have been working, (d) consider the costs of the approach being taken, and (e) if the approach is not working and the cost is high, see if the patient is willing to stop this approach [23].

Therapist’s Initial Approach

 *Therapist: By what you have told me, your pain has become a big problem for you and it has been going on a long time—3 years. I can see some of the impacts it has had in your life, such as on your work, your photography, and time spent seeking treatment.*

Ms X: Yes, it seems like pain has taken over ...

Therapist: Exactly, it seems that is a good way to say it. So, understanding that pain has taken over, can I ask you another question?

Ms X: If your question will help me get over this problem, of course.

Therapist: Ok. What is it you want from coming here to participate in this treatment?

Ms X: Well, I want to get rid of this pain, obviously. It’s ruining my life.

Therapist: Ah, that makes sense. You want to eliminate your pain because it has, as you say, ruined your life, and then I guess your life will be better again.

Ms X: Correct.

ACT FOR PAIN

Therapist: So, can I check in with the things you have been doing so far to reach this goal to eliminate pain?

Ms X: You name it, I've tried it: acupuncture, medication, herbs, rest, exercise, magnets, yoga, and more.

Therapist: Ok, you have tried many treatments focused on trying to get rid of the pain. I think that's a very natural thing to do. In your experience have these methods been successful?

Ms X: Well, some of them seem to work at the time but it all becomes very confusing, because here I am looking for another treatment. It can feel good to get away from the pain for a little while, but soon I will experience a pain flare bringing me back to square one.

Therapist: I see what you are saying. Let me ask my earlier question in a different way. What would your life look like, and what would you be doing, if your pain were not the problem it is today?

Ms X: I would be taking pictures again, be more consistent at work, and spend less time seeking treatments.

Therapist: So, is it your experience that the methods you have been using have helped you to live life this way?

Ms X: ... I never thought about it that way ...

• What exercises or techniques are used in ACT?

In practice, ACT is somewhat unique in that it often relies on the use of metaphors and experiential exercises in treatment delivery. Metaphors and stories are used in treatment and communicated in terms that fit with the experience and background of the person seeking treatment. Although therapists can select from among many widely used and often appropriate metaphors and stories, an experienced therapist is likely to create patient specific metaphors “live,” within the context of a particular session. This is consistent with the philosophical underpinning of ACT in its aims for individual tailoring of methods. Unlike other current psychotherapeutic approaches that place a higher value on sticking to a specified protocol, the theory and philosophy behind ACT allow for flexibility and are open to creativity, individual

style, and situational sensitivity of the therapist. This is expected to allow the patient to also adopt a similar sensitivity to changing environmental contingencies [19]. In ACT, the techniques typically do not follow a cookbook style of treatment delivery.

Case Continued

 *Therapist: What if trying to control your thoughts and feelings were not the answer?*

Ms X: I have no idea what you mean.

Therapist: Well, you certainly have focused a lot of your effort on trying not to have the thoughts and feelings that seem to block you.

Ms X: What else is there to do, really?

Therapist: If you are willing to experiment with something, try this. Don't think of a pineapple. (pause for 30 to 60 seconds). Ok, what happens.

Ms X: It didn't work—I kept thinking about a pineapple.

Therapist: Weird, huh? Notice what is happening here. I wonder if some of your struggles with your experiences are just like this. It's like by trying to get rid of something, there it is! I wonder if there were another way to do this, do you think you might be willing to test it out?

Ms X: Yes, I can try.

Further ACT Methods

ACT includes numerous experience-based methods and also direct rehearsal of targeted skills. In the previous scenario, the therapist might then proceed to instruction and practice of one or another type of acceptance-based skill, something like an “exposure” session or a mindfulness type of exercise that includes having the participant sit with the experience without doing anything else but observe it. The other type of method used includes metaphors that reveal how circumstances and behavior often work in life [4,16].

An Acceptance-Based Metaphor

 *Therapist: Imagine that you are new to the neighborhood and you invited all your neighbors over to a housewarming party. Everyone in the neighborhood is invited. On that day, the party's going*

great, and here comes Joe, who smells and looks like he has not bathed in days. You are embarrassed by the way he looks and smells and try to close the door on him. However, he shows you a flyer that you put up stating that everyone in the neighborhood is invited. So you let him in and quickly shove him to the kitchen so that he will not embarrass you and disrupt your party. However, to stop him from leaving the kitchen, you end up having to stand guard at the doorway. Meanwhile the party is going on and your guests are enjoying themselves, but do you notice what else is happening here?

Ms X: I've stopped myself from enjoying my party in order to keep Joe away.

Therapist: What if your pain was like Joe?

Ms X: Huh? ... Ah, I think I see what you are saying...

Therapist: It's like if you allow Joe to simply be another guest, you can do whatever you like at your party. On the other hand, if you say "no" to Joe you also say "no" to the party.

Ms X: Are you saying that it is for me to choose?

• **What is the role of therapist in modeling behavior change in ACT?**

An important distinction can be made between talking about behavior change and doing behavior change. Within the psychological flexibility model the emphasis is placed on the latter. Here, especially through the use of experiential exercises, clients are put into contact with the experiences that have coordinated unhealthy behavior patterns in the past so that more effective behavior patterns can be acquired. Treatment delivery is guided by the underlying behavioral philosophy and theory. Patients learn to reduce the dominant influence of the literal meaning of language as the only tool for behavior change. Direct experience is moved to the front of awareness and literal meaning, mental and verbal analysis, and so forth, are moved to the back [20]. In treatment, the therapist models for the patient the behavior change processes that are being targeted and also may use examples from his or her life as well as that of the patient's to

develop psychological flexibility [22]. An example might include a therapist's response to a person who shows an experience of emotional distress and struggling to manage this distress. Here the therapist, in line with ACT, instead of acting in some way to attempt to lessen the distress, would consciously show openness to the experiences and to their own reactions to helplessness around these experiences.

The therapist might say:

"I would feel tired and probably in pain too if I did what you just did. Could we do a little closed-eyes exercise? Shall we put the distressing thought you are having on the table, and focus on it, and we can "observe" what your mind does, and what happens in your body and your emotions when that thought shows up? Are you willing?"

"I'm feeling confused about this issue myself - how about both of us sitting quietly for a moment or two and observe what our minds do in response to this, just slowing things down, and watching?"

"I feel anxious when I believe that my thoughts about pain are true - like I have to do something to make it go away but I don't know how. What shows up for you when you believe such thoughts about pain?"

• **How and when should ACT be used?**

Based on current evidence how and when ACT ought to be used, as opposed to other treatment options, will be largely up to the individual professional and their level of competence. ACT is a form of CBT and many of the same guides pertain. In line with the pragmatic approach of ACT, an approach that makes ACT broadly applicable, there is no one particular manualised or scripted treatment protocol that must be adhered to in treatment for one specific condition or another. As mentioned earlier, the ACT approach does not usually follow a cookbook style of delivery, nor is it rigidly guided by strict protocols. There are protocols shared by researchers to support further development but there is no process by which these are deemed "official" or "recognized" or approved by anyone in particular.

A wide range of metaphors and exercises based on a set of behavioral principles that target a particular func-

tion has been proposed in ACT and this is part of its uniqueness as a therapeutic model.

Those developing ACT also have not required a standardised certification process to delivering ACT. Instead, they have chosen to create an open community of contributing researchers and clinicians who are “members” by virtue of their commitment to the same approach to clinical development and the same clinical model. Practicing ACT requires that the clinician is aware of their own competencies and delivers treatment accordingly.

• How effective is ACT?

Numerous studies have supported a general role of psychological flexibility in improving the well-being and physical functioning of patients with chronic pain, including patients in specialty care [24,28] and primary care [26]. Many studies support the particular role of acceptance of pain in adjustment to chronic pain [27–30]. Pain acceptance is a better predictor of outcomes than pain severity itself [31,32].

There are now several relatively large-scale studies conducted in actual clinical practice settings that demonstrate the effectiveness of ACT for chronic pain [25,27,33,34]. A more recent study, also conducted in an actual clinical practice setting, provided support for the specific treatment processes proposed within this approach [35]. This study showed that changes in traditionally conceived methods of pain management were unrelated to treatment improvements of pain intensity, physical disability, anxiety and depression for those who participated in treatment, while changes in psychological flexibility were consistently and significantly related to these improvements, with the exception of the results for depression.

Randomised Controlled Trials (RCTs)

To date, there are a total of 7 RCTs related to ACT and chronic pain [36–42], each providing supportive evidence. For example, in one of the early studies, Dahl and colleagues [36] showed that in comparison to treatment as usual, a group of workers who were at risk of long-term absenteeism from work due to pain or stress had a significant reduction in sick leave and healthcare usage after attending four hours of ACT sessions.

Wicksell and colleagues [37,38] conducted 2 separate RCTs with participants who suffered whiplash-associated

disorder (WAD) and fibromyalgia, respectively. Post-treatment results of both RCTs showed an improvement in physical functioning, depression and psychological flexibility in the treatment group with gains maintained at follow-up. In addition, participants in the treatment group with WAD showed an improvement in life satisfaction and fear of movement while those in the treatment group with fibromyalgia showed significant improvements in fibromyalgia impact, self-efficacy and anxiety. There was however no change in pain intensity in those who received the ACT-based treatments.

An ACT-based treatment including a self-help manual showed a significant increase in acceptance, satisfaction in life with a higher level of function and decreased pain intensity compared with a wait-list condition and with applied relaxation (AR) [40]. In comparison to the AR condition, participants in the ACT condition also reported a significantly higher level of engagement in meaningful activities and a willingness to experience pain. Follow-up data support the maintenance of these improvements at first follow-up but differences were not significant at the second follow-up. Both depression and anxiety scores improved in both treatment groups.

Wetherell and colleagues [39] compared the effectiveness of ACT and traditional CBT and found that they both produced positive results. Results from the study also showed higher satisfaction in participants who attended ACT treatment than those that attended CBT treatment, suggesting that ACT “is an effective and acceptable” intervention for patients with chronic pain. Overall acceptance of pain was shown to differentiate patients who could function well with chronic pain from those that continued to suffer with it after treatment.

More recently the first internet-based RCT for ACT with chronic pain was conducted [41]. The authors found a reduction in measures of pain-related distress, depressive symptoms, and anxiety, with these gains maintained at 6 months follow-up in the ACT treatment group compared with controls. The most recent RCT was a pilot trial of a group-based treatment of people with chronic pain recruited from general practices in the UK [42]. Participants were randomised to either an ACT-based treatment or treatment as usual. Participants in the ACT-based group underwent 4 sessions each lasting 4 hours with the first 3 sessions completed in 1 week and the last session completed a week later. At 3 months follow-up, participants in the ACT group had lower disability, depression, and higher pain acceptance.

In general, results from the ACT-based RCTs on chronic pain support the efficacy of the treatment and reflect a high degree of versatility, based on the wide variety of modes of delivery tested. However, RCTs for chronic pain are still relatively few with some studies limited to small sample sizes, thus making it difficult to reach definitive conclusions on the general efficacy of ACT in chronic pain treatment. What the studies do seem to show is that ACT is a good alternative treatment option to more traditionally conceived current CBT-based treatments for chronic pain. Larger sample sizes and higher quality studies are needed to strengthen and establish the effectiveness of ACT and to understand the potential impact of wider implementation in clinical practice.

Meta-Analyses

A total of 4 meta-analyses [43–46] have been conducted on acceptance- or ACT-based treatment studies. Although the earlier meta-analyses [43,44] did not separately report the effectiveness of ACT for chronic pain, they reported a moderate effect size for ACT in general, with no evidence that ACT is more effective than established treatments.

Ruiz [46] conducted a review focusing on outcome or mediation/moderation type studies that compared ACT and CBT treatments. His review was not specific to chronic pain, although one study [39] involving a sample of chronic pain patients was included. Moderate effect sizes were found that favored ACT, with ACT showing a greater impact on change processes ($g = 0.38$) compared to no impact found in CBT ($g = 0.05$).

Essentially, only one meta-analysis [45] specifically reviewed the efficacy in chronic pain studies. Pain intensity and depression were selected as primary outcome measures, with anxiety, physical well-being, and quality of life selected as secondary outcomes. Out of 22 studies that were included in the review, only 2 studies [36,37] were ACT-based RCTs, with the rest of the studies mindfulness-based interventions. The overall effect size of 0.37 was found for pain and 0.32 for depression. In general, results showed significant effect sizes for both primary and secondary outcome measures in favor of the “acceptance-based treatments.” The authors concluded that at present, mindfulness-based stress reduction programs and ACT-based programs may not be superior to CBT but could be good alternatives for people with chronic pain.

The appropriateness of using pain intensity as a primary outcome measure for ACT-based studies is questionable [45]. The focus of ACT is to increase function rather than to reduce pain symptoms; hence possibly including interference of pain in daily life might be a more appropriate outcome measure.

Other Studies

A particularly important question to answer about ACT concerns its cost-effectiveness, and we still know relatively little about this. We do know that when people participate in ACT-based treatments they are able to reduce medication use and health care visits and return to work after extended periods away from work [27,28]. It remains to conduct full health economic analyses of this type of approach for chronic pain.

ACT is known to produce significant benefits widely, in other applications apart from chronic pain, such as in workplace stress [47], psychosis [48], obsessive-compulsive disorder [49], and depression [50], among other mental health conditions [51].

• What are implications for policy makers?

Results from studies of ACT in chronic pain and in other areas are disseminating rapidly. This dissemination is aided in part by a professional organization devoted to ACT and psychological flexibility (Association for Contextual Behavioral Science; www.contextualscience.org), which has a new journal, the *Journal of Contextual Behavioral Science*, started in 2012.

With the development of ACT a focus on implementation, training, and treatment integrity began early. There was an implementation study of ACT was published by Strosahl and colleagues in 1998. Their study showed that training clinicians in ACT produced better outcomes and better treatment completion rates in an outpatient setting in comparison to clinicians not receiving this training.

Processes of training have also appeared during relatively early phases of research into ACT. Lappalainen and colleagues [52] compared the impact of treatment provided by trainee therapists trained in both a traditional CBT model and ACT. Here each trainee therapist treated one patient with traditional CBT and one with ACT. Although the therapists reported higher confidence in delivering traditional CBT, patients treated within an ACT

model showed better symptoms improvement. Also, improved acceptance during treatment significantly predicted improvements across both groups of patients. Essentially, therapists with only a limited amount of training in both models demonstrated better clinical results with ACT.

A group-based ACT intervention has also been shown to be effective in reducing stress and improving the professional performance of clinical psychology trainees [53]. Here the trainees found the intervention personally and professionally useful and a majority showed a significant increase in psychological flexibility. This supports the applicability of ACT not only as a model to guide therapy but also as a model to guide training and professional performance [54]. Other results in a pain management setting show that transitioning to ACT as a treatment model can have similar benefits and may increase job satisfaction and staff well-being [55].

• What are criticisms of ACT?

Many strong supporters of cognitive therapy and more traditional versions of CBT in the field claim that ACT is not new nor better than other current versions of CBT [56]. The proponents of ACT openly acknowledge that many methods used within ACT are adopted or modified from other established therapies [4]. Criticisms are not specific to the application of ACT with chronic pain but are based on others' perceptions of ACT as a treatment approach and treatment techniques used in ACT in general.

Ost [43] criticised ACT and the third-wave therapies on 2 main grounds. First, he concluded that ACT and the rest of the third-wave therapies were not meeting the criteria of empirically supported treatments. He further concluded that there is no strong evidence to show that ACT is more effective than cognitive therapy. The methods of the Ost review have been challenged [57], yet to a certain degree the points raised are correct. Most of the limitations noted reflect a difference in the maturity of the evidence base for ACT versus traditional CBT-based approaches. Indeed, in comparison to CBT, which is the most empirically established form of psychotherapy and an active area of research for more than 40 years, ACT can be considered to be in its infancy stage of empirically supported treatments, where treat-

ment evidence and availability of high-quality RCTs in general are few at present. Specific research on ACT for chronic pain though supportive is still preliminary to a certain degree. Even so, ACT for pain is regarded as an empirically supported treatment by the body within the American Psychological Association authorized to make this determination [58].

CONCLUSION

ACT is essentially a form of CBT, considered broadly. ACT brings with it a different philosophy and approach to science compared with some other forms of CBT—this can lead to some distinctive strategies and methods in treatment for chronic pain. Like traditionally designed CBT, however, ACT similarly aims for behavior change as the end point.

ACT is grounded in specific philosophical assumptions and includes the model of psychological flexibility at its core. Preliminary findings in broad clinical and nonclinical populations support the efficacy, effectiveness, and processes in the psychological flexibility model as mediators of change, in ACT [46,59]. Research has shown that most of the 6 ACT processes, all of those so far investigated, correlate with improved daily functioning and emotional well-being in patients with chronic pain. The evidence base for ACT is still developing. Larger trials, more carefully designed trials, and a continued focus on processes of change will be needed to strengthen this base.

Corresponding author: Su-Yin Yang, Health Psychology Section, Psychology Department, Institute of Psychiatry, King's College London, 5th Fl, Bermondsey Wing, Guy's Campus, London SE1 9RT, su-yin.yang@kcl.ac.uk.

Financial disclosures: None.

Author contributions: conception and design, SY, LMM; analysis and interpretation of data, SY; drafting of article, SY, LMM; critical revision of the article, LMM; administrative or technical support, LMM; collection and assembly of data, SY.

REFERENCES

1. Melzack R, Wall PD. Pain mechanisms: a new theory. *Science* 1965;150:971-9.
2. Fordyce WE. Behavioral methods for chronic pain and illness. St Louis: Mosby; 1976.
3. Turk DC, Meichenbaum D, Genest M. Pain and behavioral medicine: A cognitive-behavioral perspective. New York: Guildford Press; 1983.

4. Hayes SC, Strosahl KD, Wilson KG. Acceptance and commitment therapy: An experiential approach to behavior change. New York: Guilford Press; 1999.
5. McCracken LM. Contextual cognitive-behavioral therapy for chronic pain. Seattle: IASP Press; 2005.
6. Leventhal H, Brissette I, Leventhal EA. The common-sense model of self-regulation of health and illness. In: Cameron LD, Leventhal H, editors. The self-regulation of health and illness behaviour. London: Routledge; 2003:42–65.
7. Gatchel RJ, Peng YB, Peters ML, et al. The biopsychosocial approach to chronic pain: scientific advances and future directions. *Psychol Bull* 2007;133:581–624.
8. Kerns RD, Sellinger J, Goodin BR. Psychological treatment of chronic pain. *Ann Rev Clin Psychol* 2011;7:411–34.
9. Williams AC, Eccleston C, Morley S. Psychological therapies for the management of chronic pain (excluding headache) in adults. *Cochrane Database Sys Rev* 2012, Issue 11.
10. Vlaeyen JWS, Morley S. Cognitive-behavioral treatments for chronic pain: what works for whom? *Clin J Pain* 2005;21:1–8.
11. Eccleston C, Williams AC, Morley S. Psychological therapies for the management of chronic pain (excluding headaches) in adults. *Cochrane Database Sys Rev* 2009, Issue 2.
12. McCracken LM, Samuel VM. The role of avoidance, pacing, and other activity patterns in chronic pain. *Pain* 2007;130:119–25.
13. Lynch TR, Chapman AL, Rosenthal MZ, et al. Mechanisms of change in dialectical behavior therapy: theoretical and empirical observations. *J Clin Psych* 2006;62:459–80.
14. Esmer G, Blum J, Rulf J, et al. Mindfulness-based stress reduction for failed back surgery syndrome: a randomized controlled trial. *J Am Osteopath Assoc* 2010;10:646–52.
15. Morone NE, Greco CM, Weiner DK. Mindfulness meditation for the treatment of chronic low back pain in older adults: a randomized controlled pilot study. *Pain* 2008;134:310–9.
16. Hayes SC, Strosahl KD, Wilson KG. Acceptance and commitment therapy: the process and practice of mindful change. 2nd ed. New York: Guilford Press; 2012.
17. Hayes SC, Villatte M, Levin M, Hildebrandt M. Open, aware and active: Contextual approaches as an emerging trend in the behavioural and cognitive therapies. *Annu Rev Clin Psychol* 2011;7:141–68.
18. Hayes S, Luoma J, Bond F, et al. Acceptance and commitment therapy: model processes and outcomes. *Behav Res Ther* 2006;44:1–25.
19. Gaudiano BA. A review of acceptance and commitment therapy (ACT) and recommendations for continued scientific advancement. *Sci Rev Mental Health Prac* 2011;8:5–22.
20. Twohig MP. Introduction: the basics of acceptance and commitment therapy. *Cog and Behav Pract* 2012;19:499–618.
21. McCracken LM, Yang S. The role of values in a contextual cognitive-behavioral approach to chronic pain. *Pain* 2006;123:137–45.
22. Luoma JB, Hayes SC, Walser RD. Learning ACT: an acceptance and commitment therapy skills-training manual for therapists. Oakland, CA: New Harbinger Pub; 2007.
23. Strosahl K, Robinson P, Gustavsson T. Brief interventions for radical change: principles and practice of focused acceptance and commitment therapy. Oakland, CA: New Harbinger Pub; 2012.
24. McCracken LM, Vowles KE, Zhao-O'Brien J. Further development of an instrument to assess psychological flexibility in people with chronic pain. *J Behav Med* 2010;33:346–54.
25. McCracken LM, Gutierrez-Martinez O. Processes of change in psychological flexibility in an interdisciplinary group-based treatment for chronic pain based on acceptance and commitment therapy. *Behav Res Ther* 2011;49:267–74.
26. McCracken LM, Velleman SC. Psychological flexibility in adults with chronic pain: a study of acceptance, mindfulness, and values-based action in primary care. *Pain* 2010;148:141–7.
27. McCracken LM, Vowles KE, Eccleston C. Acceptance-based treatment for persons with complex, long standing chronic pain: a preliminary analysis of treatment outcome in comparison to a waiting phase. *Behav Res Ther* 2005;43:1335–46.
28. McCracken LM, MacKichan F, Eccleston C. Contextual cognitive-behavioural therapy for severely disabled chronic pain sufferers: Effectiveness and clinically significant change. *Eur J Pain* 2007;11:314–22.
29. Wicksell RK, Melin L, Olsson GL. Exposure and acceptance in the rehabilitation of adolescents with idiopathic chronic pain—a pilot study. *Eur J Pain* 2007;11:779–87.
30. Wicksell RK, Olsson GL, Hayes SC. Psychological flexibility as a mediator of improvement in acceptance and commitment therapy for patients with chronic pain following whiplash. *Eur J Pain* 2010;14:1059.e1–1059.e11.
31. McCracken LM, Vowles KE, Eccleston C. Acceptance of chronic pain: component analysis and a revised assessment method. *Pain* 2004;107:159–66.
32. McCracken LM, Eccleston C. Coping or acceptance: what to do about chronic pain? *Pain* 2003;105:197–204.
33. Vowles KE, McCracken LM. Acceptance and values-based action in chronic pain: a study treatment effectiveness and process. *J Consult Clin Psychol* 2008;76:397–407.
34. Vowles KE, McCracken LM, Eccleston C. Processes of behaviour change in interdisciplinary treatment of chronic pain: Contributions of pain intensity, catastrophizing, and acceptance. *Eur J Pain* 2007;11:779–87.
35. Vowles KE, McCracken LM. Comparing the role of psychological flexibility and traditional pain management coping strategies in chronic pain treatment outcomes. *Beh Res Ther* 2010;48:141–6.
36. Dahl J, Wilson KG, Nilsson A. Acceptance and commitment therapy and the treatment of persons at risk for long-term disability resulting from stress and pain symptoms: a preliminary randomized trial. *Behav Ther* 2004;35:785–802.
37. Wicksell RK, Ahlqvist J, Bring A, et al. Can exposure and acceptance strategies improve functioning and life satisfaction in people with chronic pain and whiplash-associated disorders (WAD)? A randomized controlled trial. *Cog Behav Ther* 2009;38:169–82.
38. Wicksell RK, Kemani M, Jensen K, et al. Acceptance and commitment therapy for fibromyalgia: a randomized controlled trial. *Eur J Pain* 2013;17:599–611.

39. Wetherell JL, Afari N, Rutledge T, et al. A randomized, controlled trial of acceptance and commitment therapy and cognitive-behavioural therapy for chronic pain. *Pain* 2011;152:2098-107.
40. Thorsell J, Finnes A, Dahl J, et al. A comparative study of 2 manual-based self-help interventions, acceptance and commitment therapy and applied relaxation for person with chronic pain. *Clin J Pain* 2011;27:716-23.
41. Buhrman M, Skoglund A, Husell J, et al. Guided internet-delivered acceptance and commitment therapy for chronic pain patients: a randomized controlled trial. *Beh Res Ther* 2013;51:307-15.
42. McCracken LM, Sato A, Taylor GJ. A trial of a brief group-based form of acceptance and commitment therapy (ACT) for chronic pain in general practice: pilot outcome and process results. *J Pain* 2013;14:1398-406.
43. Ost L-G. Efficacy of the third wave of behavioral therapies: A systematic review and meta-analysis. *Behav Res Ther* 2008;46:296-321.
44. Powers MB, Zum Vorde Sive Vording MB, Emmelkamp PMG. Acceptance and commitment therapy: a meta-analytic review. *Psychother Psychosom* 2009;78:73-80.
45. Veehof MM, Oskam MJ, Schreurs KM, Bohlmeijer ET. Acceptance-based intervention for the treatment of chronic pain: a systematic review and meta-analysis. *Pain* 2011;152:533-42.
46. Ruiz FJ. Acceptance and commitment therapy versus traditional cognitive behavioral therapy: a systematic review and meta-analysis of current empirical evidence. *Int J Psychol Psycholog Ther* 2012;12:333-57.
47. Bond FW, Bunce D. The role of acceptance and job control in mental health, job satisfaction, and work performance. *J App Psych* 2003;88:1057-67.
48. Gaudiano BA, Herbert JD. Acute treatment of inpatients with psychotic symptoms using acceptance and commitment therapy: pilot results. *Behav Res Ther* 2006;44:415-37.
49. Twohig MP, Hayes SC, Masuda A. Increasing willingness to experience obsessions: Acceptance and commitment therapy as a treatment for obsessive-compulsive disorder. *Behav Ther* 2006;37:3-13.
50. Zettle RD, Hayes SC. Dysfunctional control by client verbal behaviour. The context of reason giving. *Analys Verbal Behav* 1986;4:30-8.
51. Forman EM, Herbert JD, Morita E, et al. A randomised controlled effectiveness trial of acceptance and commitment therapy and cognitive therapy for anxiety and depression. *Behav Mod* 2007;31:772-99.
52. Lappalainen R, Lehtonen T, Skarp E, et al. The impact of CBT and ACT models using psychology trainee therapists: A preliminary controlled effectiveness trial. *Behav Modif* 2007;31:488-511.
53. Stafford-Brown J, Pakenham KI. The effectiveness of an ACT informed intervention for managing stress and improving therapist qualities in clinical psychology trainees. *J Clin Psychol* 2012;68:592-613.
54. Pakenham KI, Stafford-Brown J. Postgraduate clinical psychology students' perceptions of an acceptance and commitment therapy stress management intervention and clinical training. *Clin Psych* 2012;17:56-66.
55. Barker E, McCracken LM. From traditional cognitive behavioral therapy to acceptance and commitment therapy for chronic pain: a mixed method study of staff experiences of change. *Brit J Pain* published online 19 Jul 2013.
56. Hoffmann SG, Asmundson GJ. Acceptance and mindfulness-based therapy: new wave or old hat? *Clin Psych Rev* 2008;28:1-16.
57. Gaudiano BA. Ost's (2008) methodological comparison of clinical trials of acceptance and commitment therapy versus cognitive behavior therapy: matching apples with oranges? *Behav Res Ther* 2009;47:1066-70.
58. Division 12. APA psychological treatments. Niwot, CO: American Psychological Association. Available at www.div12.org/PsychologicalTreatments/treatments.html.
59. Levin ME, Hildebrandt MJ, Lillis J, Hayes SC. The impact of treatment components suggested by the psychological flexibility model: A meta-analysis of laboratory-based component studies. *Behav Ther* 2012;43:741-56.

Copyright 2014 by Turner White Communications Inc., Wayne, PA. All rights reserved.