

This electronic thesis or dissertation has been downloaded from the King's Research Portal at <https://kclpure.kcl.ac.uk/portal/>



PTPN22/Lyp: A novel regulator of integrin signalling and function in T lymphocytes

Burn, Garth Lawrence

Awarding institution:
King's College London

The copyright of this thesis rests with the author and no quotation from it or information derived from it may be published without proper acknowledgement.

END USER LICENCE AGREEMENT



Unless another licence is stated on the immediately following page this work is licensed

under a Creative Commons Attribution-NonCommercial-NoDerivatives 4.0 International

licence. <https://creativecommons.org/licenses/by-nc-nd/4.0/>

You are free to copy, distribute and transmit the work

Under the following conditions:

- Attribution: You must attribute the work in the manner specified by the author (but not in any way that suggests that they endorse you or your use of the work).
- Non Commercial: You may not use this work for commercial purposes.
- No Derivative Works - You may not alter, transform, or build upon this work.

Any of these conditions can be waived if you receive permission from the author. Your fair dealings and other rights are in no way affected by the above.

Take down policy

If you believe that this document breaches copyright please contact librarypure@kcl.ac.uk providing details, and we will remove access to the work immediately and investigate your claim.

PTPN22/Lyp: A novel regulator of integrin signalling and function in T lymphocytes

Garth Lawrence Burn

Kings College London

September 2014

Supervisor

Professor Andrew Cope

I, Garth Lawrence Burn, confirm that the work presented in this thesis is my own.

Where information has been derived from other sources, I confirm that this has been indicated in the thesis.

Acknowledgements

To my supervisors Andy Cope and Lena Svensson: Thank you for all your help and support and giving me an opportunity to do some science. I know I probably drove you both bonkers from time to time but we got there in the end. I look forward to working with both of you in the future.

Cope laboratory. It has been an absolute pleasure working with each and every one of you. It has been a privilege. Georgina, thank you for all your love and support. We will be friends for life.

To the students I worked with: Mark Yates, Sophie Minoughan and Mike Shannon. I am not sure what happened but you all did a stupendous job at helping me. Most people moan about students, but let me just say that you guys were really one of the highlights of my PhD. You are all very gifted people.

I would also like to thank Marc Dionne. Some people think it is weird I had you as my screensaver on my computer for a year (including your wife)...but really you were such an integral part of my PhD and you always had time for me. You helped me to think and grow.

Chris, James and Jiten (notice this is alphabetical so no arguing over who is more important please). You guys are just awesome; we have all been friends now for over 15 years. That's nearly legal. They say you are only as good as the people you surround yourself with. I am starting to believe it!

Probably the most important people in my life, without whom this would not have been possible, are my Mom, Dad and Sister. Thank you for all your love and support. You all believed in me when nobody else did. I love you all very very much.

Finally to my new lab: The Dylan Owen Group! You have all been very patient waiting for me to finish up and start with you. I am so excited! Dylan, thanks for everything you did for me during my PhD, I can't wait to get biophysical with you. George, Juliette and Mike, you guys have been very supportive in waiting for me to finish my PhD-SEE YOU SOON! YAY!! xxx

Contents

Acknowledgements.....	3
Abstract.....	9
Abbreviations.....	11
Chapter 1 Introduction	14
1.1 PTPN22: one signalling intermediate regulates many different pathways	16
1.2 Protein Tyrosine Phosphatases and Protein Tyrosine Kinases are immune cell gatekeepers.....	18
1.3 Genetic associations between PTPN22 allelic variants and autoimmunity.....	20
1.5 The function of Lyp in leukocytes.....	30
1.6 Lyp regulates T cell receptor signalling.....	34
1.6.1 How is T cell receptor signalling initiated?	37
1.7 Role of Lyp in B cells.....	41
1.8 Functional studies of disease associated Lyp R620W	42
1.9 How does R620W contribute to disease development?	48
1.10 The role of Lyp in integrin biology	50
1.11 Integrins in immunobiology	51
1.17 The role of adhesion and migration in T cell responses	52
1.18 What controls integrin activation?	53
1.19 Inside-out signalling leading to integrin activation.....	56
The control of RAP1 guanine exchange factors	58
RAP1 as an activator of LFA-1	59
The final steps of inside-out signalling.....	61
1.20 Outside-in signalling.....	63
Platelets as a model system for outside-in signalling.....	64
Outside-in signalling in immune cells	65
1.21 Negative regulators of integrin signalling.....	72
1.22 Project Aim.....	73
Chapter 2 Materials and Methods.....	74
2.1 Molecular biology	75
2.1.1 Molecular biology reagents	75
2.1.2 DNA/RNA isolation, reverse transcription, plasmid isolation and gel purification....	76

2.1.2.1 DNA precipitation	76
2.1.2.2 DNA ligations.....	77
2.1.2.3 Preparation of competent cells	78
1.3 Site directed mutagenesis.....	82
1.4 Preparation of Lyp-GFP fusion constructs	86
2.1.5 Restriction Fragment Length Polymorphism (RFLP) for PTPN22 genotyping.....	89
2.1.5.1 Polymerase Chain Reaction (PCR).....	89
2.1.5.2 DNA Genotyping	91
2.2. Cell culture	92
2.2.1 PBMC isolation and T cell culturing	92
2.2.2 Isolation of human T cells by negative selection	93
2.2.3 Isolation and culture of murine T cells from lymphoid organs.....	93
2.2.4 Transfection of cell lines	93
2.3. Biochemistry	95
2.3.1 Western Blotting.....	95
2.3.2 Preparing cell lysates in sample buffer	95
2.3.3 Preparing cell lysates in cell lysis buffers.....	96
2.3.4 Immunoprecipitation and Co-immunoprecipitation	97
2.3.5 Signalling Experiments.....	98
3.5.1 Plate bound integrin signalling assay.....	98
2.3.6 SDS-PAGE, protein transfer and probing with antibodies	99
2.4. IMAGING	100
2.4.1 Cell fixation using pH shift method.....	100
2.4.2 Timelapse microscopy.....	101
2.4.3 Confocal microscopy.....	102
2.4.5 STORM oxygen scavenging buffer	103
2.5. Flow cytometry	104
2.5.1 Staining protocol:.....	104
2.5.2 Lyp staining:	105
2.5.3 FACS sorting	105
2.6. Antibodies and Reagents	106
Chapter 3 The Lyp-Csk-PAG complex regulates Lck phosphorylation downstream of LFA-1 engagement	107
3.1 Lyp is up regulated in activated T cells	108
3.2 Lyp localises to the leading and lagging edge of migrating T cells.	112

3.3 Lyp, Csk and PAG colocalise at the leading and lagging edge of migrating T cells	116
3.4 Dynamics of the Lyp-Csk-PAG complex in T blasts migrating on ICAM-1	119
3.4.1 Lyp associates with Csk when T cells migrate on ICAM-1.....	119
3.4.2 The interaction between Lyp and Csk is completely abolished in rested T cells	125
3.4.3 PAG and Csk dissociate when T cells migrate on ICAM-1	128
3.4.4 PAG is dephosphorylated when T cells migrate on ICAM-1	134
3.4.5 Csk tonically phosphorylates the inhibitory residue of Lck pY505 when T cells are immobilised on PLL and following LFA-1 engagement this inhibitory tyrosine residue is dephosphorylated.....	137
3.4.6 Csk and Lyp dissociate from PAG when T cells migrate on ICAM-1.....	141
3.5 Summary of the dynamics of the Lyp/Csk/PAG complex	144
Discussion.....	145
Chapter 4 The regulation of T cell migration by PTPN22/Lyp.....	152
4.1 The effects of Lyp knockdown on static T cell migration.....	153
4.2 The catalytic activity of Lyp is required to regulate T cell migration	159
4.6 Functional analysis of T cells from PTPN22 genotyped donors	164
Discussion.....	170
Chapter 5 Analysis of integrin signalling and its regulation by PTPN22/Lyp	174
5.1 Optimising a protocol for integrin signalling	176
5.2 Integrins signal through a common module in T cells.	177
5.3 Signalling is sustained in T cells migrating on fibronectin, VCAM and ICAM-1	181
5.4 Lyp associates with phospho-proteins when T cells migrate on ICAM-1	185
5.5 Lyp targets phosphorylated Lck, ZAP-70 and VAV when T cells migrate on ICAM-1.....	188
5.6 Stoichiometric changes in the LFA-1/Lck/ZAP-70/Vav complex when T cells migrate on ICAM-1	194
5.7 Lyp and Csk associate with LFA-1 when T cells migrate on ICAM-1	198
5.8 LFA-1 and Lyp co-localise in migrating T cells.....	200
5.9 Lyp co-localises with Csk, Lck, ZAP-70 and VAV in migrating T cells.....	202
5.10 The R620W SNP leads to increased phospho-ERK1/2 activity when LFA-1 binds ICAM	204
Discussion.....	206
Chapter 6 Nanoscale organisation of Lyp	212
Super-resolution imaging of Lyp.....	213
6.1 Lyp de-clusters upon engagement of LFA-1 in migrating T blasts.	215
6.2 The dynamics of Lyp declustering at the membrane.....	220

6.3 Organisation of the disease associated Lyp mutant at the membrane of migrating cells.	229
6.4 Less Lyp-W620 can be detected at the leading edge membrane in migrating T cells....	232
6.5 Disease associated Lyp-W620 is more clustered at the plasma membrane when T cells migrate.....	234
6.8 Lyp clustering is unperturbed by a mutation in a polyproline binding domain.....	238
6.10 Ripleys K function reveals that Lyp-W620 is more clustered than Lyp-R620 at the membrane in migrating T cells.	243
6.11 Modelling reveals that molecules outside of the cluster can dictate the downslope of Ripley K function.	246
6.12 Lyp-W620 is associated with increased LFA-1 clustering when T cells migrate on ICAM-1	252
Discussion.....	262
Chapter 7 Concluding Discussion.....	267
7.1 Lyp regulates multiple signalling pathways including LFA-1.....	268
7.2 How does Lyp, Csk and PAG regulate signalling pathways?	269
7.3 Lyp declusters to target its substrates	275
7.4 How is signal specificity achieved through the usage of similar signalling intermediates by different receptors?	277
7.5 Signalling through LFA-1	280
7.6 The consequences of a single nucleotide polymorphism within a binding domain of Lyp	283
Concluding remarks	287
Appendix	315

<p>A CD is attached at the back of this thesis corresponding to figure 6.6: Live cell imaging of Lyp at the membrane in resting cells (1 frame/second)</p>
--

Abstract

Integrins are large heterodimeric surface receptors that, when engaged, are able to transduce information from the extracellular environment leading to a diverse set of cellular programmes including migratory responses. Despite a wealth of literature describing how integrins on T cells are activated such that they can bind to their ligand, the nature and regulation of the signal transduced via the integrin cytoplasmic tails once the integrin engages its counter-ligand is not yet clear. Here, we report that in primary human and mouse T cells, PTPN22, a cytoplasmic protein tyrosine phosphatase expressed only in immune cells, negatively regulates signal transduction downstream of LFA-1 engagement.

Loss of *PTPN22*/*Lyp* expression enhances integrin-mediated adhesion and migration *in vitro* and *in vivo*, while overexpression of wild type *Lyp*-R620 decreased migration. The catalytic activity of PTPN22 was required in order to regulate T cell migration. Co-immunoprecipitation experiments demonstrated that PTPN22 associated with Lck, ZAP-70, Vav and LFA-1 in migrating T blasts. In performing shear flow experiments and biophysical investigations, human individuals homozygous for the disease associated R620W mutation functionally recapitulated the phenotype of PTPN22 knockout mouse cells in that they were more adherent and demonstrated hyperphosphorylation of signalling intermediates downstream of LFA-1 engagement.

Super resolution microscopy revealed that in non-signalling T cells, PTPN22 formed large clusters that appeared to de-cluster following LFA-1 engagement. Surprisingly, the R620W mutation did not appear to impact clustering, but instead lead to less *Lyp*

monomers being retained at the membrane outside of clusters in signalling T cells. A correlate between less Lyp monomers and increased LFA-1 clustering at the leading edge of migrating T cells is demonstrated, with an inverse relationship existing between number of Lyp monomers present at the plasma membrane and LFA-1 clustering.

These studies place PTPN22 as a novel negative regulator downstream of LFA-1 signalling, with a disease predisposing R620W mutation lending itself to a loss-of-function allele that might impact the development of autoimmune disease through dysregulation of integrin function.

Abbreviations

ADAP:	adhesion and degranulation-promoting adaptor protein
APC:	antigen presenting cell
BSA:	Bovine Serum Albumin
CaIDAG-GEFI:	calcium, diacylglycerol, guanine nucleotide exchange factor I
cDNA:	complimentary DNA
CHO:	chinese hamster ovary
DC:	dendritic cell
ECL:	enhanced luminol based chemiluminescence
FACS:	fluorescent activated cell sorting
FCS:	fetal calf serum
FERM:	protein 4.1, Ezrin, Radixin, Moesin
FRET:	Forster Resonance Energy Transfer
GEF:	guanine nucleotide exchange factor
GFP:	green fluorescent protein
GPCR:	G protein coupled receptor
HBSS:	Hanks Buffered Saline Solution

HEPES:	4-(2-hydroxyethyl)-1-piperazineethanesulphonic acid
HEV:	high endothelial venule
HRP:	horseradish peroxidase
ICAM-1:	intercellular adhesion molecule-1
IL-2:	interleukin-2
ITAM:	immunoreceptor tyrosine activation motif
LAD:	leukocyte adhesion deficiency
LFA-1:	lymphocyte functional antigen 1
Lyp:	Lymphoid tyrosine phosphatase
mAb:	monoclonal antibody
MHC:	major histocompatibility complex
NK cell :	Natural Killer cells
NOB-GP:	N-octyl-8-glucoopyranoside
PEP:	proline enriched phosphatase
PAGE:	polyacrylamide gel electrophoresis
PBS:	phosphate buffered saline
PKC:	Protein kinase C
PLL:	Poly-L-Lysine
PTK:	Protein tyrosine Kinase

PTP:	Protein tyrosine phosphatase
RA:	Rheumatoid arthritis
RAP1:	Ras related protein 1
RAPL:	Regulator for cell adhesion and Polarisation enriched in lymphoid tissue
RIAM:	RAP-1-GTP-interacting adaptor protein
SH2:	Src homology domain 2
SH3:	Src homology domain 3
siRNA:	small interfering RNA
SKAP55:	Src kinase associated phosphoprotein
SLP-76:	leukocyte protein of 76kDa
TCR:	T cell receptor
TIRF:	total internal reflection fluorescence
VCAM-1:	vascular cell adhesion molecule 1

Chapter 1
Introduction

The immune system comprises a set of cells that work in concert to protect the host from invading pathogens and cancers. The ability of immune cells to ward off, contain or destroy invaders that might compromise healthy tissue function is a central tenet of the system, leading to fitness and survival. On the other hand, because the immune system is essentially a “loaded gun”, capable of destroying both self and non-self, inappropriate activation, or indeed over or under activation leading to the collateral damage of tissues, can manifest in immunopathology or autoimmunity. How exactly decisions are made by an individual cell to react to a certain stimulus remains at the forefront of investigation, and in particular, the complex networks involving information transduction leading to an adaptive cellular programme are beginning to be uncovered. The process of information transduction in cells is often referred to as signalling. In this thesis, the *PTPN22* locus, which encodes LYmphoid Protein tyrosine phosphatase (Lyp) in man and Proline Enriched Phosphatase (PEP) in mouse is investigated as a potential regulator of signalling downstream of a family of adhesion receptors called integrins on T cells. Hereafter, I will refer to PTPN22 and Lyp interchangeably.

1.1 PTPN22: one signalling intermediate regulates many different pathways

In T cells, PTPN22 has been shown to regulate signals generated in response to T cell receptor engagement. As a result, many studies have focused on the ability of PTPN22 to regulate T cell receptor signalling. It is however clear that many signalling intermediates participate in more than one signalling pathway, leading to completely different cellular outcomes depending on the type of receptor engaged. PTPN22 can be viewed as one such intermediate, with reports of this phosphatase participating in many different signalling pathways, including T cell receptor (TCR) signalling, B cell receptor BCR Signalling, interferon signalling and Toll-Like Receptor signalling. (Arechiga, Habib et al. 2009, Fiorillo, Orru et al. 2010, de la Puerta, Trinidad et al. 2013, Spalinger, Lang et al. 2013, Spalinger, Lang et al. 2013, Wang, Shaked et al. 2013). Cells can therefore be viewed as exercising a certain amount of economy with respect to signalling intermediate biology, which makes sense from an evolutionary perspective, where one pathway diverges over time to form another, with subtle differences in the divergence of a pathway being responsible for driving new cellular programmes (Atkins 2014). That T cell receptor signalling utilises many signalling intermediates non-exclusively, a plausible hypothesis is that these same signalling intermediates, shared amongst different receptor signalling pathways, might be subject to similar mechanisms of regulation. In this vein, it was of interest to investigate whether PTPN22, a signalling intermediate traditionally thought of as a negative regulator of T cell receptor signalling, also participated in the negative regulation of integrins. This idea was borne out of the fact that integrin signalling in T cells shares many similarities with the T cell receptor (Fagerholm, Hilden et al. 2002, Evans, Lellouch et al. 2011, Cimo, Ahmed et al. 2013). The current state of PTPN22 biology is reviewed below.

This review focuses on the genetic, epidemiological, biochemical and functional aspects of PTPN22 with particular emphasis on the regulation of T cell receptor signalling, because most of the knowledge about signal transduction and how it is regulated by PTPN22 comes from the TCR signalling literature.

1.2 Protein Tyrosine Phosphatases and Protein Tyrosine Kinases are immune cell gatekeepers

Protein Tyrosine Phosphatases (PTPs) and Protein Tyrosine Kinases (PTKs) are enzymes that specifically catalyse the reversible addition or release of phosphate groups from tyrosine residues on signalling intermediates. Broadly speaking, PTKs amplify signals whilst the mode, tempo and duration of the signal are governed by PTPs. PTPs and PTKs are divided into 2 groups: receptor (membrane bound-RPTP) or non-receptor (cytoplasmic-NRPTP). These signalling intermediates are messengers that are recruited when transducing messages from the extracellular environment into the cell and lead ultimately to changes in cell behaviour. Phosphorylation/dephosphorylation by PTKs and PTPs on inhibitory, activatory or scaffolding tyrosine on signalling intermediates are the equivalent of molecular switches leading to changes in protein behaviour that are associated with increased or decreased signalling. Post-translational modifications of proteins by the addition or release of phosphate groups alters enzymatic activity or binding domain affinity which act as functional units by propagating a series of molecular interactions and reactions. Protein phosphorylation status can therefore be viewed as a fundamental, coordinated process that must be tightly controlled. This is particularly true in the context of an immune response, where cells must be activated under appropriate circumstances to fight infections and tumours, but avoid self directed responses that culminate in autoimmunity (Mustelin and Tasken 2003, Mustelin, Alonso et al. 2004, Mustelin, Vang et al. 2005).

There are around 110 PTPs that have been identified in the human phosphoproteome (proteins that encode protein tyrosine phosphatases or kinases) and at least 57 of these are expressed in lymphocytes. PTPs and PTKs control the highly complex and dynamic nature of signal transduction pathways associated with many cellular processes as diverse as differentiation, migration, apoptosis, proliferation and activation of immune cells (Arimura and

Yagi 2010). The tonic inhibition of basal PTK activation requires PTPase activity to be several orders of magnitude higher than that of PTK activity. PTPs were once thought largely to play housekeeping functions by non-specifically binding and dephosphorylating signalling intermediates. It has, however, become increasingly evident that PTPs bind with exquisite specificity to certain signalling intermediates through protein-protein interaction domains or lipid binding modules and in many cases play non-redundant roles. This notion is exemplified in the context of the immune system by immunopathology exhibited by mouse models in which certain phosphatases are dysfunctional or deleted and implicates signalling intermediates as important messengers that are responsible for setting at least some of the thresholds associated with immune activation. These mutations can be naturally occurring or engineered and point to the importance of phosphatase function in maintaining immune homeostasis.

For example, a loss-of-function of PTP SHP-1 mutation, which negatively regulates TCR signalling leads to the *motheaten* phenotype characterised by immunodeficiency, autoimmunity and lymphoproliferation (Kozlowski, Mlinaric-Rascan et al. 1993, Tsui and Tsui 1994). A gain in function of CD45, which has been shown to be a positive regulator of TCR and BCR signalling, predisposes mice to an autoimmune-like syndrome (Majeti, Xu et al. 2000). While mouse models provide insight into the importance of phosphatase function, little is known about phosphatases that contribute to disease in humans. In recent years, genome wide association studies have repeatedly identified candidate PTPs that associate with autoimmune disease. These include *PTPN2*, *PTPRC*, *UBASH3A*, *PTPN11*, *PTPRT* and *PTPN22*, and points to dysregulation of protein tyrosine phosphorylation as a crucial facet of immunopathology.

1.3 Genetic associations between PTPN22 allelic variants and autoimmunity

In recent years, human genetic studies have identified a growing number of gene candidates that associate with autoimmune disease. There are 3 approaches that can be utilised when investigating genetic variants that might contribute to the development of autoimmune disease states. These include candidate gene association studies, linkage analysis in multiplex families and genome wide association studies (GWAS). Statistical tools have been developed to complement each approach, but a lack of appreciation for careful case controls when conducting candidate gene studies and low statistical power of genetic linkage analysis has compromised the validity of some of these studies (Gregersen and Olsson 2009). A strong publication bias of candidate gene studies that report positive findings has also been documented (Ioannidis, Ntzani et al. 2001). Results from these studies should therefore be treated with caution until they have been validated unambiguously in replication studies.

GWAS are currently considered the most effective way of mining for new disease associated gene variants since this approach is purely discovery driven, conducted by scanning whole genomes without any particular hypothesis in mind. GWAS can be limited by the fact that only relatively common gene variants are identified because of the reference genomes used and the relatively small sample sizes. In many cases the actual causative genetic variants cannot be precisely identified because of linkage disequilibrium between causal variants and the haplotype tagging single nucleotide polymorphisms (SNPs) employed to detect variants across the genome. SNPs found within specific genes in people who have been diagnosed with autoimmune disorders provide clues that, after fine genetic mapping at selected loci, must then be investigated in a biological framework to understand its contribution to disease development. This in turn can pave the way for exploring potential therapeutic interventions. Common disease variants may point to pathways that might become plausible targets for

therapeutic intervention. However, it should be noted that a recent study that sequenced two T1D associated genes in 13, 715 individuals revealed that European populations, probably as a result of recent accelerating population growth, harbour many rare, deleterious variants that may contribute significantly to disease burden in these populations, but which are not detected through conventional GWAS (Coventry, Bull-Otterson et al. 2010).

In 2004 a seminal paper by Bottini *et al* reported an association between a SNP in *PTPN22* and T1D in two distinct populations, using a candidate gene approach (Bottini, Musumeci et al. 2004). A transitional mutation changing a cytosine to a thymine at position 1858 in the coding region of the *PTPN22* gene resulted in a single amino acid change of an arginine to a tryptophan at codon 620 in exon 14. This R620W amino acid substitution is located in a polyproline motif, PLPXR, within the Lyp phosphatase protein thought to be involved in binding to SH3 domains during protein-protein interactions (Cloutier and Veillette 1996). Within 1 year SLE and RA were reported to also associate with R620W and following a multitude of studies it has now become evident that this polymorphism is an allelic variant associated with susceptibility to a growing number of autoimmune diseases (Table 1.1). Strikingly, the association is highly reproducible, found in many different populations and is restricted to disorders that usually have an autoantibody component. A perplexing gradient frequency of the allele has been reported to exist.

Autoimmune disease	Odds ratio
Rheumatoid arthritis (15)	1.3-2.13
T1D (7)	1.5-2.39
SLE (5)	1.42-2.56
Hashimotos thyroiditis (4)	1.62-1.77
Addisons (1)	1.69
Juvenile idiopathic arthritis (3)	1.17-1.7
Wegeners granulomatosis (1)	1.76
Graves disease (1)	1.7
Systemic sclerosis (1)	1.09
Vitiligo (1)	1.82

Table 1.1 PTPN22 associates with autoimmune diseases. The number of studies pooled is indicated in brackets. Based on references 1-34.

The highest frequency of the allele is found in the most northerly and easterly reaches of the continent in Finland (15%) and the Ukraine (17%) and its neighbouring lands. Moving southwest, the frequency of the allele gradually decreases to around 7% in France and Spain and is found in only 2-3% of Italian and Sardinian populations (Figure .11) (Bottini, Musumeci et al. 2004, Smyth, Cooper et al. 2004, Velaga, Wilson et al. 2004, Hinks, Barton et al. 2005, Ittah, Gottenberg et al. 2005, Orozco, Sanchez et al. 2005, Seldin, Shigeta et al. 2005, Skorka, Bednarczuk et al. 2005, Viken, Amundsen et al. 2005, Wesoly, van der Helm-van Mil et al. 2005, Zhernakova, Eerligh et al. 2005, Fedetz, Matesanz et al. 2006, Gregersen, Lee et al. 2006, Cinek, Hradsky et al. 2007, Douroudis, Prans et al. 2008). American and Australian white European descendants carry the allele at a frequency of 6-9%. In Asian and African populations the allele is virtually absent (Begovich, Carlton et al. 2004). This observation indicates that the polymorphism in *PTPN22* probably arose late in human evolution in a European population(s). It may confer a selective advantage. In support of this notion, extended haplotype homozygosity studies have indicated that the *PTPN22* locus may be under positive selection, at least in populations of European ancestry (McPartland, Norris et al. 2007). There has been interest as to whether R620W may protect carriers from infectious disease because there have been reports of potential autoimmune susceptibility loci protecting individuals from environmental pathogens (Gomez, Anaya et al. 2005, Waisberg, Tarasenko et al. 2010). Studies have indicated that carriers of R620W in Europe may be protected from tuberculosis (Lopez-Escamez 2010) but the protection from tuberculosis may be population dependent as others have reported an increase in susceptibility to tuberculosis in a Moroccan population carrying R620W (Lamsyah, Rueda et al. 2009). R620W is a risk factor in the development of invasive pneumococcal disease, indicating that *PTPN22* is a susceptibility gene for autoimmunity and certain infections (Chapman, Khor et al. 2006). Other studies investigating the involvement of R620W in the protection from or susceptibility to Hepatitis C infection (Montes-Cano, Garcia-Lozano et al. 2008), *Trypanosoma Cruzi* infection (Robledo, Gonzalez et al. 2007) and

brucellosis (Bravo, Colmenero et al. 2009) have demonstrated no differences between control groups and R620W carriers. Further association studies of R620W with infection might provide useful information about the frequency distribution of the allele and its possible relationship with an infectious agent.

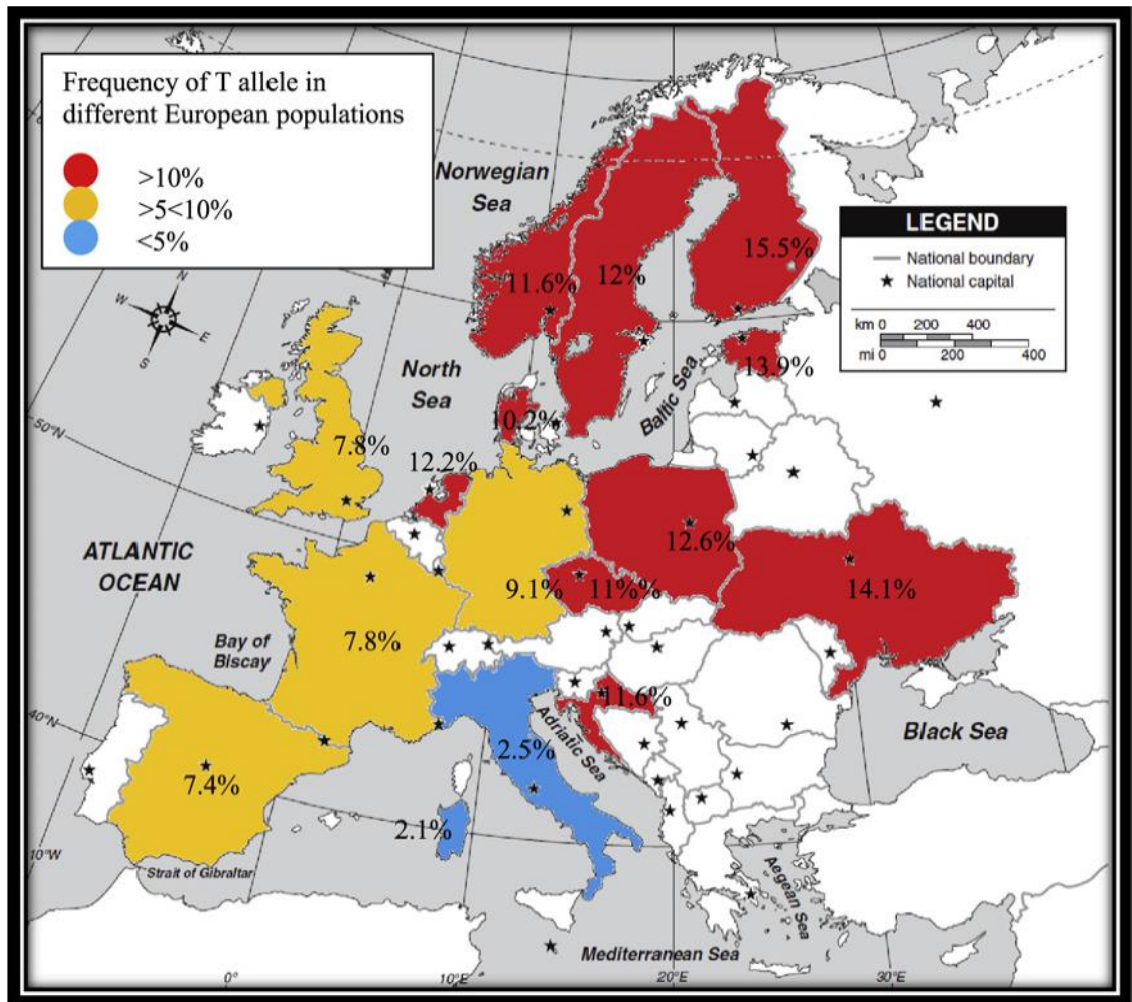

Figure 1.1: The frequency distribution of the minor T allele across the European continent. Here, I constructed a heatmap based on table 1.1 showing the frequency distribution of the autoimmune disease associated W620-Lyp. An East to West gradient is demonstrated. Adapted from www.eduplace.com/ss/maps/

1.4 The structure of Lyp

Catalytic domains of PTPs are highly conserved and can thus be targeted using degenerate primers in PCR reactions that will amplify non-conserved flanking regions. The resultant PCR product can then be compared to known PTP sequences and validated or investigated further if a novel stretch of DNA is identified. Using this method, Lyp was identified in 1999 as a 105kDa Class 1 NRPTP, belonging to the proline-, glutamic acid-, serine- and threonine-rich (PEST) family of phosphatases. Its mouse orthologue, proline enriched phosphatase (PEP), was discovered in 1992 (Matthews, Bowne et al. 1992, Cohen, Dadi et al. 1999).

Structurally Lyp and PEP consist of an N-terminal catalytic domain, an interdomain and a C-terminal binding domain that contains four polyproline-rich motifs (P1-P4) that act as potential binding sites for Src Homology 3 (SH3) protein domains. Lyp and PEP are the most divergent example of phosphatase orthologues between human and murine species (89% and 61% homology in their catalytic and non-catalytic domains respectively) although most of these differences lie within the interdomain that may be important for regulating phosphatase activity (Gjorloff-Wingren, Saxena et al. 1999, Liu, Stanford et al. 2009). There have been some hints in the literature of subtle biochemical differences between PEP and Lyp and so extrapolation from murine models to human biology should be undertaken with some caution.

Structure and regulation of Lyp

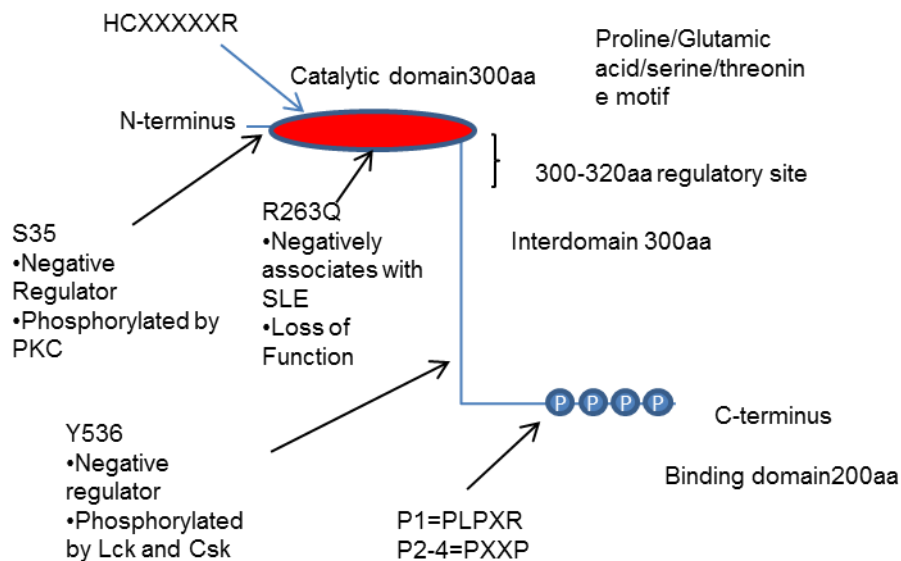

Figure 1.2: Structure and regulation of Lyp. The catalytic site of Lyp that confers the ability of dephosphorylation resides in the most N-terminal of the protein spanning around 300 amino acids. A loss of function R263Q SNP that negatively associates with SLE (ie may confer protection against SLE) has been reported. In addition, a serine at position 35 has been reported to be phosphorylated by protein kinase C (PKC) leading to attenuation of catalysis. The interdomain of Lyp consist of a further 300 amino acids whose functions remains largely unknown. There is one study indicating that the first 20 amino acids (300-320) may contribute to phosphatase regulation, although mechanistically it is unclear how this regulation occurs. Within the interdomain, Y536 has been shown to be phosphorylated by Lck and Csk, leading to negative regulation and decreased catalytic potentials. Most C-terminally, the binding domain of Lyp consists of around 200 amino acids. The binding domain of Lyp contains four polyproline binding motifs, the first of which harbours the R620W mutation. The first polyproline motif of the binding domain is unique as compared to the other three motifs, in that it is a high affinity SH3 binding domain. The R620W variant disrupts Lyp-Csk interactions.

Lyp exists in 3 splice forms designated Lyp1-3 (Cohen, Dadi et al. 1999, Wang, Dong et al. 2010) (Fig 1.3). The full length protein of 807aa, Lyp1, is the most abundant of the 3 isoforms and has

been the subject of all functional studies to date. Lyp2 is the shortest splice variant and contains only the first P1 motif within the N-terminal whilst Lyp3 has a 28 amino acid deletion between P1 and P2. The functions of Lyp2 and Lyp3 are not known. Lyp can be membrane bound through interactions with other proteins, or cytosolic, but the subcellular location of the different isoforms has not yet been reported. The expression of Lyp is confined exclusively to haematopoietic cells and a clear hierarchy exists in the expression profile across immune cell lineages with respect to Lyp abundance (Arimura and Yagi 2010). Natural Killer cells and neutrophils express the highest levels of Lyp, followed by CD8+ T cells while CD4+ T cells and monocytes express the lowest levels of Lyp. Lyp expression in activated versus non-activated cells requires further investigation.

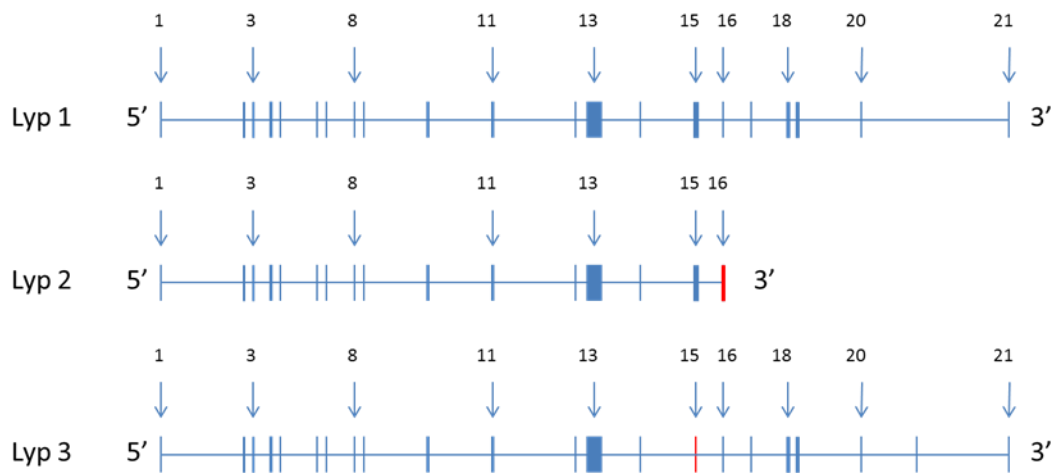

Figure 1.3: Lyp isoforms1-3. A schematic demonstrating the exons (vertical bars) and introns (horizontal lines) of Lyp1-3. Approximate sizes of exons and introns are shown. Lyp2 is a truncated form of Lyp1 with a bigger exon 16. Lyp3 has a 28bp deletion in exon 15. Red denotes a change in exon composition. Adapted from Zang et al 2010

1.5 The function of Lyp in leukocytes

Immune cells must cooperate to mount and maintain an appropriate response and dysregulation of practically any cell type could lead to immunopathology or immunodeficiency. Over the past 20 years much effort has been invested in understanding the various pathways that trigger immune cell activation, and the relative contribution of the different lineages to an immune response. T and B cell receptors represent some of the best studied signalling machinery and even though they recognise peptides through completely different antigen receptor structures, they share many PTKs, PTPs and adaptor molecules (Mustelin and Tasken 2003, Smith-Garvin, Koretzky et al. 2009, Pierce and Liu 2010). The Src and Syk kinase families are crucial positive regulators of immune cell activation through B and T cell receptors as well as other immunoreceptors like Fc receptors (FcR) and Natural Killer Cell receptors termed killer immunoglobulin receptors. At least some of the Src and Syk kinase family are targeted and inactivated by Lyp as demonstrated by substrate trapping experiments (Figure 1.4). Lyp may therefore represent a key regulator of immunoreceptor dependent activation of many leukocyte functions.

Although our understanding of Lyp function in T cells has broadened since the association of W620-Lyp with autoimmune disease there is still a lack of data describing signalling pathways other than that of the TCR. Further study of Lyp is required in the lymphoid compartment but is also merited in the context of other immune cells to generate ideas about fundamental biological processes that could lead to new hypotheses with respect to autoimmune diseases.

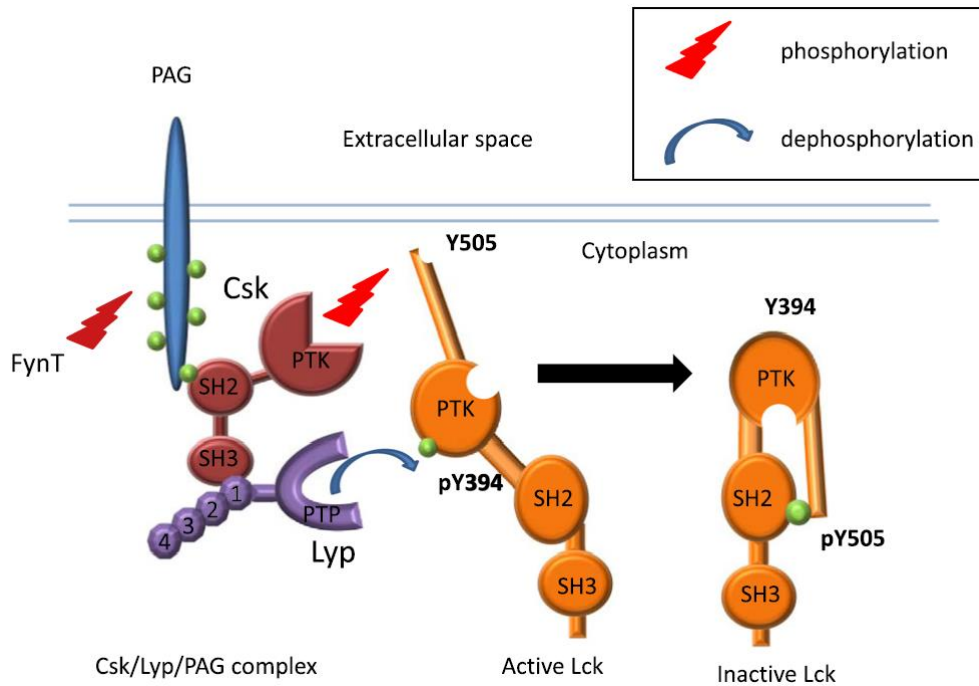

Figure 1.4: Lyp and Csk inactivate Lck. The Lyp-Csk interaction is mediated through the first polyproline motif in Lyp and the SH3 domain of Csk. PAG, when phosphorylated by Fyn, acts as a scaffold recruiting Csk through and SH2 domain that binds phosphorylated tyrosine residues. Csk phosphorylates pY505 creating an SH2 binding site that results in an internal fold and partial inactivation of Lck. For Lck to be fully inactivated, Lyp dephosphorylates Y394 residue within the kinase domain of Lck leading to attenuation of catalytic activity.

In order to delineate signalling pathways, it is important to identify target substrates of signalling intermediates. To this end, Flint *et al* have developed a method whereby important PTP catalytic residues in the N-terminus are mutated and the resultant non-functional catalytic domain is then fused to a glutathione-S-transferase protein allowing substrates to interact with but not disassociate from a PTP due to the lack of catalytic activity that leads to post-translational protein modifications and the release of modified substrate (Flint, Tiganis *et al.* 1997). This method, or a variation thereof, has been widely employed as the substrate trap is sufficiently stable to allow subsequent isolation of PTP-substrate complexes by co-immunoprecipitation. Substrate trapping should always be interpreted with care, especially when using candidate substrates purified from whole cell lysates or PTP catalytic domain-GST fusion proteins as they do not respect binding domain interactions or sub-cellular localisation of their native counterparts, both of which may be intimately linked. This is because protein interaction domains have been shown to be essential for subcellular location as well as protein binding (Uchida, Ogata *et al.* 2002, Saito, Williams *et al.* 2007). In addition, immune cells can display many different levels of activation that may also contribute to substrate localisation and recognition (Arimura and Yagi 2010).

Substrate trapping experiments in the human Jurkat T cell line indicate that Lyp interacts with Lck, ζ -associated protein 70 (ZAP70), Vav, CD3 ϵ , TCR ζ , valosine containing protein (VCP), Grb2 and c-Cbl (Cloutier and Veillette 1999, Hill, Zozulya *et al.* 2002, Wu, Katrekar *et al.* 2006). In addition to the substrates of Lyp, PEP targets FynT (Cloutier and Veillette 1999). These substrates are known to participate in proximal signalling events following T cell receptor (TCR) engagement with MHC-peptide complexes. One exception to this is VCP, which has many apparently unrelated functions including retrotranslocation of unfolded proteins into the endoplasmic reticulum, the homotypic fusion of smooth endoplasmic reticulum membranes,

NF- κ B activation, reformation of golgi cisternae and nuclear envelope reassembly (Woodman 2003). The significance of this finding is currently unknown.

1.6 Lyp regulates T cell receptor signalling

Src and Syk family kinases are key activators of T cell receptor signalling and are negatively regulated by Lyp (Figure 1.5) (Gjorloff-Wingren, Saxena et al. 2000, Wu, Katrekar et al. 2006). The Src family kinase Lck is phosphorylated on an inhibitory tyrosine residue Y505 under steady state by C-terminal Src kinase (Csk) creating an internal SH2 binding domain which facilitates the so called "tailbite" inactive conformation of Lck (Bergman, Mustelin et al. 1992, Nika, Tautz et al. 2007). Csk is located in the cytoplasm but can target the plasma membrane through direct interactions with a high affinity SH2 binding site on a transmembrane protein found in lipid rafts termed Csk binding protein (CBP) or protein associated with GEMS (PAG). It has been proposed that Lyp may be targeted to the plasma membrane through interactions with Csk, although this has never been formally demonstrated. An unusually high affinity interaction between the P1 domain motif PLPXR on Lyp and an SH3 binding domain on Csk promotes the formation of the Csk/Lyp complex that may act to synergistically inhibit proximal TCR signalling (Gregorieff, Cloutier et al. 1998, Cloutier and Veillette 1999). Following TCR engagement, PAG is dephosphorylated, possibly by CD45, releasing Csk which may then form homodimers through its SH3 domains inhibiting its own catalytic activity (Levinson, Visperas et al. 2009). In addition, the disengagement of the SH2 domain of Csk from PAG leads to an attenuation of Csk catalytic activity (Wong, Lieser et al. 2005). The regulation of Csk via its SH2 domain engaging PAG makes sense, because it is through this association that Csk localises to rafts where its activity is required to regulate Src family kinase members (Bergman, Mustelin et al. 1992, Amrein, Molnos et al. 1998, Davidson, Bakinowski et al. 2003, Schoenborn, Tan et al. 2011, Tan, Manz et al. 2014). Using a human derived T cell line, the Gjorloff-Wingren group showed that mouse PEP localises at the cell membrane but recent studies using mouse cells failed to identify the phosphatase in lipid rafts (Gjorloff-Wingren, Saxena et al. 2000, Maksumova, Le et al. 2005). Recent studies have suggested that Lyp, following a T cell receptor stimulation with an anti-CD3, actually dissociates from Csk in the cytoplasm, after which it is

recruited into rafts where it regulates active signal. In this model, the authors propose that Lyp-Csk binding is inhibitory on the phosphatase (Vang, Liu et al. 2012). These studies were however one dimensional, with no imaging data to back this hypothesis. Clearly, much more work must be done to understand the context in which Lyp and Csk are interacting, and how Lyp is targeted to the membrane.

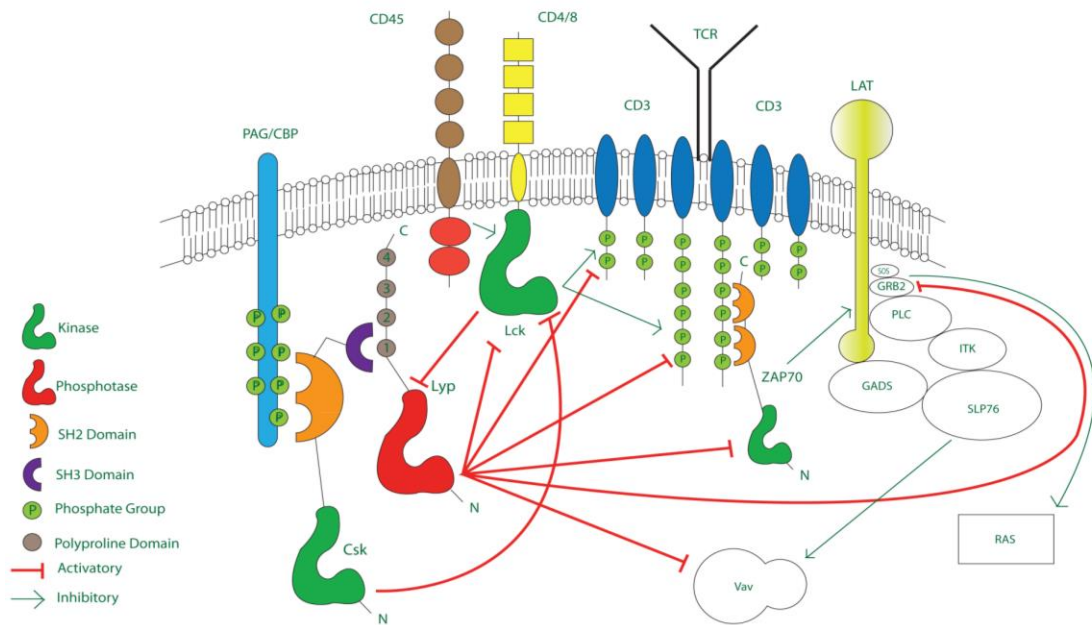

Figure 1.5. Lyp acts on multiple proximal T cell receptor signalling intermediates. Substrate trapping experiments indicate that Lyp can interact with Lck, ZAP-70, TCR ζ and CD3 ϵ ITAMS, Grb2 and Vav. In this schematic I have shown Lyp and Csk to be associated with PAG as a complex, but little is known about the nature of this complex and whether it even exists. Clearly Lyp and Csk can complex, but whether this complex can in turn bind to PAG requires further investigation. Moreover, it is unclear whether the Lyp-Csk complex is able to target substrates. The regulation of signalling by Lyp and Csk might be very complex, with these intermediates being able to act in solo, or coupled to one another depending on the signalling context. Perhaps some intermediates that are shared substrates between Lyp and Csk, like Lck (Lyp targets pY394 and Csk targets pY505) is targeted by a Lyp-Csk complex whilst other intermediates that have never before been shown to interact with Csk, like ZAP-70 and Vav, are targeted by Lyp alone. Moreover, very little is known about when Lyp is targeting its substrates and its importance during the maintenance of pathway “off” states (a tonic and active off signal), its importance in regulating active signal or a role possibly in signal termination.

1.6.1 How is T cell receptor signalling initiated?

The understanding of how T cell receptor signalling proceeds might help to clarify the role of Lyp during this process. Recent work by Weiss and colleagues suggests that one of the first events governing T cell activation might be the removal of tonic inhibitory signals mediated by Csk. The acute inhibition of Csk leads to Lck activation and a TCR signal in the absence of receptor ligation (Schoenborn, Tan et al. 2011, Tan, Manz et al. 2014). The release of Csk from PAG might therefore represent one of the first steps leading to TCR activation. CD45, a positive regulator of TCR signalling through its ability to antagonise the action of Csk, then dephosphorylates Lck at the inhibitory pY505 as the dynamic equilibrium shifts toward a more “on” state of signalling when Csk is removed from rafts (Majeti, Xu et al. 2000, Davidson, Bakinowski et al. 2003, Maksumova, Le et al. 2005, Nika, Tautz et al. 2007). Lck then autophosphorylates activatory tyrosine residue Y394 within the activation loop of the kinase domain. In fact, recent work seems to suggest that no net changes in Lck activation are required to initiate a signal, and instead an “already active” pool is recruited to the TCR to initiate signalling (Nika, Soldani et al. 2010). Another interpretation of these results is that the net levels of Lck activation are very closely monitored and adjusted such that activating Lck in one cellular compartment might lead to its inactivation within another compartment. Lyp dephosphorylates Lck at this activatory site (Wu, Katrekar et al. 2006). Thus Lyp may form a part of the feedback loop monitoring and adjusting the basal levels of Lck pY394 or, alternatively, Lyp may be responsible for making sure that during a signal Lck levels do not go unchecked. How exactly Lyp and Csk might cooperate to negatively regulate signalling pathways is unknown, but studies using single knockouts of Csk and Lyp and double Csk/Lyp knockouts would be of use here.

Recent studies indicate that activated Lck may also regulate Lyp function by phosphorylating an inhibitory tyrosine residue, Y536, thereby inactivating Lyp (Fiorillo, Orru et al. 2010). Thus a situation can be envisaged where Lck and Lyp dynamically regulate one another, and allow for

local changes in phosphorylation that may facilitate optimal TCR responses. The precise stoichiometry of the interactions that promote Lyp phosphorylation by Lck is complex and remains to be determined, but Csk microclusters may facilitate this interaction through SH2 binding sites that allows the docking of Lck and subsequent phosphorylation and inactivation of Csk associated Lyp. Clarification of the sequence of events that govern inhibition of Lck by Csk and Lyp are also required, since Csk preferentially targets activated Lck that is phosphorylated at Y394 as demonstrated by in vitro kinase assays and phosphopeptide mapping, suggesting that Lyp may play a part in the targeting of Lck by Csk (Amrein, Molnos et al. 1998). The regulation of Lck has also been brought into question in recent years and it is becoming evident that acute dephosphorylation of Y505 may not be necessary for Lck activation and TCR signalling (Paster, Paar et al. 2009, Nika, Soldani et al. 2010). Clarification of why there are primed pools of Lck at steady state and the implications of these findings with respect to TCR signalling is important to further our understanding of the role Lyp plays during these events.

Once activated, Lck phosphorylates immunoreceptor tyrosine-based activation motifs (ITAMS) on TCR ζ , CD3 ϵ , CD3 γ and CD3 δ creating high affinity binding sites for the tandem SH2 domains of ZAP-70, a Syk family protein tyrosine kinase that contains multiple inhibitory and activatory tyrosyl residues located at Y292, Y492 and Y319, Y493 respectively (Wange, Guitian et al. 1995, Lupper, Songyang et al. 1997). ZAP-70 is phosphorylated by Lck on residues Y319, Y493 and is activated following its recruitment through tandemly arranged SH2 domains to phosphorylated ITAM motifs located on TCR subunits. ZAP-70 then targets multiple substrates and is itself a substrate of Lyp through direct interactions (Wu, Katrekar et al. 2006). There is some speculation that Lyp might also target ZAP-70 through the E3 ubiquitin ligase c-Cbl which docks onto the phosphorylated inhibitory residue of ZAP-70 promoting inactivation through

dephosphorylation of activatory residues by Lyp. In support of this notion, Lyp has been reported to target c-Cbl but this relationship remains unclear (Mustelin, Alonso et al. 2004).

ZAP-70 phosphorylates proximal TCR signalling intermediates and adaptors that are targeted and perhaps negatively regulated by Lyp including Grb2 and Vav. Grb2 positively regulates TCR activation in cooperation with CD28 by activating Ras/Raf/MEK/ERK pathway (Nunes, Collette et al. 1994, Schneider, Cai et al. 1995). It has been postulated that Grb2 might play a dual role by delivering Lyp to CTLA-4 (a relative of CD28 and a negative regulator of co-stimulation) which has SH3 and SH2 domains capable of binding adaptor molecules thereby participating in downregulation of TCR signalling (Brand, Gough et al. 2005, Arimura and Yagi 2010). Studies have shown that Lyp and CTLA-4 upregulate and co-localise following TCR activation (Cohen, Dadi et al. 1999).

Vav, an atypical guanine exchange factor and controller of calcium fluxing involved in cytoskeletal rearrangements and immune synapse formation is targeted and activated by ZAP-70 (Swat and Fujikawa 2005). Studies have yet to address the contribution of Lyp in regulating Vav function. Given the importance of the immune synapse in governing the outcome of APC-lymphocyte and lymphocyte-target cell interactions, studies exploring the role of Lyp in regulating such processes are warranted. Interestingly, a family member of Lyp, PTP-PEST, has been shown to dephosphorylate cytoskeletal and focal adhesion proteins CAS, PYK2, FAK and paxillin that mediate integrin activation (Garton, Flint et al. 1996, Cote, Charest et al. 1998). PTP-HCSF is also implicated in regulating cytoskeletal dynamics (Spencer, Dowbenko et al. 1997). Taken together, the PTP-PEST family may function as important regulators of the cytoskeleton and adhesion molecules in immune cells. This might be in line with our hypothesis that Lyp regulates integrin signalling, which clearly impacts cytoskeletal dynamics.

These observations imply that Lyp may play an important function in the tonic inhibition of TCR function, active TCR signalling and the shutting down of T cell activation after engagement of the TCR complex. Since Lyp is upregulated following TCR engagement, it is quite feasible that modulation of signalling in effector T cells is an important function of this phosphatase. Characterisation of the PEP deficient mouse revealed an increase in the proportion of effector and memory populations of T cells which would be entirely in keeping with the putative functions of Lyp. To date, there have been no reports that PEP deficient mice are more susceptible to autoimmune or lymphoproliferative disease. One group have shown, however, that mice deficient of PEP which also harbour a CD45 SNP encoding a constitutively active phosphatase that positively regulates antigen receptor signalling cooperate to break tolerance (Zikherman, Hermiston et al. 2009).

1.7 Role of Lyp in B cells

Because B cells share much of their signalling machinery with T cells it is likely that Lyp may regulate proximal B cell receptor signalling in a similar fashion, but substrate trapping experiments have not been undertaken in B cells. There is some evidence that there may be impairment of signalling in human individuals carrying the R620W variant (as discussed below). The PEP deficient mouse, on the other hand, shows no alteration in signalling through the BCR as evidenced by normal calcium mobilisation following BCR engagement. Other labs have published on the role of PEP expression in B cells on disease but these studies, despite being very interesting, are outside of the scope of this project, but some of these studies are discussed in more detail later on (Menard, Saadoun et al. 2011, Dai, James et al. 2013).

1.8 Functional studies of disease associated Lyp R620W

The R620W mutation functions in an autosomal dominant fashion with increased clinical penetrance in carriers who are homozygous. R620W associates with type 1 diabetes (Bottini, Musumeci et al. 2004), rheumatoid arthritis (Begovich, Carlton et al. 2004), systemic lupus erythematosus (Kyogoku, Langefeld et al. 2004), Hashimotos thyroiditis (Chabchoub, Teixeira et al. 2009), Graves disease (Skorka, Bednarczuk et al. 2005), Addisons disease (Velaga, Wilson et al. 2004), myasthenia gravis (Vandiedonck, Capdevielle et al. 2006), vitiligo (Canton, Akhtar et al. 2005) and systemic sclerosis (Diaz-Gallo, Gourh et al. 2010). Understanding precisely how and why this allelic variant contributes to disease development is of considerable interest from a biological and therapeutic point of view.

The arginine-tryptophan substitution within the P1 domain of Lyp at position 620 and the resulting autoimmune risk is difficult to study because our knowledge about the biochemistry of native Lyp and its functional importance remain limited. The expression profile of Lyp across all immune cells and immune cell precursors (like thymocytes) also makes it difficult to predict which cell types to prioritise when investigating functional differences between R620W and R620. In addition to R620W, other *PTPN22* variants have been reported to associate with or confer resistance to the development of autoimmune disease. For example an R263Q mutant has been shown to negatively associate with SLE and RA and is reportedly a loss-of-function variant (Orru, Tsai et al. 2009). There are also reports of a SNP found within the promoter region of *PTPN22* that associates with RA and T1D in an Asian cohort (Kawasaki, Awata et al. 2006, Huang, Qiu et al. 2010).

The mutation in the P1 domain of Lyp has been proposed to disrupt the binding of R620W to Csk (Bottini, Musumeci et al. 2004) as compared to R620. Despite these two molecules having opposing kinase/phosphatase activity, as described above, they both serve to inhibit T cell function, possibly synergistically (Cloutier and Veillette 1999). Disruption of the Csk/Lyp complex might then lead to altered thresholds of antigen receptor signalling affecting the education of T cells in the thymus or B cells in the bone marrow, activation of naive T and B cells and effector/memory cell populations.

Functional studies investigating T cell activation thresholds in the context of R620W using primary cells and T cells lines by the Bottini group demonstrated reduced IL-2 production, decreased activity of transcription factors NFAT/AP1 and reduced calcium mobilisation in response to anti-CD3 and anti-CD28 stimulation as compared to cells harbouring wild type R620. A phosphatase assay using a peptide modelled on Lck, a physiological substrate of Lyp, that directly monitored the enzyme kinetics of R620W and R620 demonstrated that R620W was catalytically more active leading to a gain of phosphatase activity and an associated attenuation of TCR signalling (Mustelin, Vang et al. 2005). These results should be interpreted with caution because the authors used primary cells from patients with T1D and it is possible that other autoimmune susceptibility genes encoding functionally and/or immunologically related proteins may be acting independently or in cooperation with R620W leading to the aforementioned cellular effects. Nonetheless, reduced TCR signalling has been reported by two other groups in healthy individuals (to exclude the effects of disease or drug treatment) as well as patients with T1D and RA (Rieck, Arechiga et al. 2007, Aarnisalo, Treszl et al. 2008). Interestingly, these studies reported conflicting data pertaining to proliferative responses of T cells despite using identical protocols, possibly as a result of using paediatric vs adult patients or fresh vs frozen samples, with Aarnisalo reporting a reduced proliferative capacity and Rieck showing no difference between R620W and R620, but altered cytokine levels were in

agreement with decreased expression of IL-2. Rieck also reported decreased levels of IL-4 and IL-10. The memory T cell pool was expanded in the study by Rieck, as determined by the frequency of CD4+, CD45RO+ cells. In another study using primary T cells derived from Myasthenia Gravis sufferers, an increase in the number of cells producing IL-2 (using ELISpot) was shown in R620W carriers compared to non-carriers but the measurement of IL-2 levels was not undertaken (Lefvert, Zhao et al. 2008). The results indicate that increased numbers of T cells in R620W carriers respond to stimulation but the magnitude of IL-2 response by individual cells is decreased, since other studies have shown there are decreased overall levels of IL-2 production.

These studies flag up two important questions. First, how does a mutation outside the catalytic domain lead to increased enzyme activity? Second, how could an apparent attenuation of TCR signalling lead to autoimmune disease? The complex regulation of PTPs through oxidation events that favour intramolecular formation of inhibitory disulphide bridges, inhibitory/activatory tyrosine, serine and threonine phosphorylation sites, internal binding sites and pseudophosphatases makes it difficult to delineate the mechanism by which R620W might function as a gain-of-function mutant (Osisanya, Sehgal et al. 1990, Tonks 2006, Tsai, Sen et al. 2009). Recent studies have shown that Lck dependent phosphorylation of Lyp on an inhibitory tyrosine residue might be an important regulatory mechanism which positively influences TCR signalling (Fiorillo, Orru et al. 2010). The interaction between Lyp and Csk is proposed to facilitate the interactions between Lck and Lyp. R620W cannot bind Csk efficiently and so this mutant may be a gain-of-function Lyp mutant by virtue of its failure to be appropriately regulated by Lck *in vivo*, essentially leading to a constitutively active Lyp. This model does not explain why, *in vitro*, R620W has increased phosphatase activity (Bottini, Musumeci et al. 2004). A more recent study suggested that Lyp and Csk dissociate following TCR engagement leading to Lyp being recruited into rafts where it actively regulates signal. In

this model, the complexing of Csk and Lyp leads to Lyp inactivation, and only when dissociated can Lyp target and dephosphorylate substrates. The authors concluded that the binding domain mutation which disrupts Lyp-Csk complexing leads to a gain-of-function phenotype since Lyp is not properly regulated (Vang, Liu et al. 2012). In complete opposition to this, but perhaps more in line with my results, others have countered this observation by suggesting that Lyp and Csk complex following receptor engagement (de la Puerta, Trinidad et al. 2013). Others have reported a negative regulatory S35 site located near the catalytic domain that is phosphorylated by PKC (Yu, Sun et al. 2007). Direct interaction between the interdomain and the catalytic domain of Lyp and PEP has also been postulated as an important regulatory mechanism leading to decreased phosphatase activity but the trigger and context of this interaction remains unknown (Gjorloff-Wingren, Saxena et al. 1999, Liu, Stanford et al. 2009).

The second question pertaining to how hyporesponsive T cells might lead to autoimmunity is more straightforward. Studies of the SKG mouse demonstrated that attenuation of TCR signalling due to a loss of function ZAP-70 mutation leads to impaired ZAP-70 and dysregulated thymic selection. Our laboratory has also demonstrated the importance of reduced IL-2 production in this model, as well as skewed Th cell differentiation. Thus, immunodeficiency manifested by defective TCR signalling can, rather counter-intuitively, lead to autoimmunity. The allelic series of ZAP-70 mutants described by Goodnow and colleagues has also highlighted how this defective state can have subtle effects on distinct thymic and peripheral T cell subsets within both effector and regulatory compartments (Siggs, Miosge et al. 2007). Here, it is important to appreciate that immunopathology is not just as a consequence of hyperactivation of the immune system, and that there is a balance, and this balance can be tipped by under or over-activation.

While there is accumulating evidence to suggest R620W is a gain-of-function mutant in the context of TCR signalling, others have countered this hypothesis by suggesting that under circumstances where Csk is co-expressed at comparable levels the disease associated Lyp variant is hypomorphic (Zikherman, Hermiston et al. 2009). In this study using both human and mouse *PTPN22* variants the authors showed that disease associated Lyp and PEP transfected into Jurkat T cells in combination with Csk are not as efficient at inhibiting Erk phosphorylation as their wild type counterparts and an increase in calcium flux was demonstrated in Lyp and PEP mutant expressing cells. Further studies are needed in primary cells to test if these results hold true under more physiologically relevant conditions. A controversial study more recently by the Siminivitch lab proposed that the mutant is loss-of-function due to its propensity to be degraded via a calpain-mediated pathway, although these results have not been observed by other labs (Zhang, Zahir et al. 2011, Vang, Liu et al. 2012, Dai, James et al. 2013).

In considering B cells, signalling is apparently unperturbed in PEP^{-/-} mice (there are however altered B cell pools and hypergammaglobulinaemia) but signalling in human B cells harbouring R620W is altered (Rieck, Arechiga et al. 2007, Arechiga, Habib et al. 2009). The association of autoantibody production with R620W might point to intrinsic B cell anomalies or altered help/activation by T cells or both. Studies using B cells derived from R620W carriers demonstrate smaller memory pools that are hyporesponsive to stimulation through the BCR in terms of proliferation, display reduced basal level phosphorylation of signalling intermediates and tyrosine phosphorylation following stimulation. What is intriguing about B cell studies is that naive cells seem unaffected by R620W. These results imply that Lyp may have an important role in modulating B cell signalling after activation and its role therefore in tonic inhibition, at least in B cells, may be a minor one. In fact, studies using the PEP^{-/-} mouse indicate that signalling in naïve T cells is also normal. Taken together these results suggest that in terms of signalling, Lyp appears to play a more important role in the memory and effector

cell pools when compared to naïve lymphocytes. The observation that expression of both Lyp and PEP are upregulated in activated T cells may be relevant (Arimura and Yagi 2010).

1.9 How does R620W contribute to disease development?

Studies indicate that there are biological differences between the common Lyp R620 and the disease associated Lyp R620W variant. How these differences might manifest in autoimmune disease remains to be uncovered. There is still no clear consensus as to whether R620W is a gain- or loss-of-function variant and there is a possibility that in the future there may be newly discovered functions of the mutant phosphatase. It is not inconceivable that R620W may exert both gain- and loss-of-function activity in different pathways but within the same cell. Another possibility is that the mutant Lyp may have different effects in cells of different lineages.

The most obvious subset of immune cells that are inextricably linked to autoimmunity are lymphocytes but the coordination of an immune response requires the participation of all immune cells and the origin of an adaptive autoimmune response may not necessarily be due to intrinsic defects in the lymphoid compartment. For example, dendritic cells express high levels of Lyp and are responsible for presenting antigen to and polarising Th cells. Inappropriate activation of T cells may therefore arise as a consequence of aberrant antigen presenting cell function leading to the development of autoimmune disease.

One possibility by which R620W might contribute to disease is through changes in thresholds of thymic selection. The involvement of Lyp during positive and negative selection has not been reported but its high expression in thymocytes might point to an important function during T cell education. Interestingly, the thymus (and the prostate) is the only tissue in which all 3 Lyp isoforms can be detected (Wang, Dong et al. 2010). If the disease associated variant turns out to be gain-of-function, high affinity self-reactive TCR expressing T cells might escape negative selection resulting in an expanded repertoire of autoreactive T cells and an

augmented predisposition to autoimmune disease. Conversely, a loss-of-function R620W mutant may act on the very few cells that, per chance, escape negative selection, leading to enhanced and/or sustained T cell activation and driving T cell differentiation of effector T cells in the periphery, leading ultimately to an autoimmune phenotype.

An alternative explanation for autoimmune disease development in individuals carrying R620W is its effect on T regulatory cells (Tregs). Experiments in the early 1990s by Sakaguchi and colleagues reignited the interest in these self reactive T cells that escape negative selection and express high levels of CD25 on their surface (Sakaguchi, Ono et al. 2006). These naturally occurring self reactive T cells with immunoregulatory properties are proposed to be a main player in preventing the emergence of autoimmunity in the periphery. If the gain-of-function hypothesis is correct, Treg function may be compromised leading to deficient regulation of autoreactive T cells in the periphery.

Finally, more work is required in the context of other immune cells as well as other receptors expressed on T cells. Immunoreceptor signalling is often governed by Src and Syk kinases which are both substrates of Lyp. Lyp potentially influences any given immunoreceptor that utilises the Src and Syk kinases and some of these receptors have been shown to be important contributors to autoimmune disease. Recognition of immune deposits through Fc receptors in lupus by immune cells is thought to be a major driving force of disease (Waldman and Madaio 2005). One study has already highlighted the importance of Lyp in NK cell proliferation in vitro (Douroudis, Shcherbakova et al. 2010). NK cells have been demonstrated to contribute to autoimmunity in various ways, and an imbalance of these cells in vivo might tip the scale in favour of an autoimmune phenotype (Flodstrom-Tullberg, Bryceson et al. 2009).

1.10 The role of Lyp in integrin biology

At the outset of my PhD studies it was not known whether Lyp regulates integrin signalling. Given the commonalities between the signalling intermediates utilised by the T cell receptor and integrin receptors, it seemed plausible that Lyp might regulate signalling downstream of integrins. I now review integrin biology in the next section, with particular emphasis on signalling involving Src and Syk family kinases, both of which have been shown to participate in integrin and T cell receptor biology, and both of which are PTPN22/Lyp substrates.

1.11 Integrins in immunobiology

Integrins are heterodimeric, bi-directional signalling receptors (Hynes 2002). Integrins play a diverse role in cellular biology, influencing proliferation, differentiation, migration and adhesion, survival and tissue architecture. The heterodimer consists of an α and a β subunit, of which 18 and 8 exist, respectively. The various permutations of α and β subunits have led to the identification of a total of 24 heterodimers being expressed on the surface of a wide range of cells. Haematopoietic cells express, in addition to other integrins, the $\beta 2$ subfamily of integrins (Tan 2012). $\beta 2$ integrins are highly expressed on leukocytes, suggesting an important function for this integrin family specifically in immune cells. Indeed mutations in the $\beta 2$ chain or elements associated with $\beta 2$ function are deleterious, leading in some cases to death if a bone marrow transplant is not performed (Alon, Aker et al. 2003, Kinashi, Aker et al. 2004, Manevich-Mendelson, Feigelson et al. 2009, Moser, Bauer et al. 2009, Svensson, Howarth et al. 2009, van de Vijver, Tool et al. 2014). The cause of death in susceptible individuals that do not have properly functioning $\beta 2$ has been ascribed to the inability of blood cells to exit the vasculature via the endothelium and enter target tissues where they participate in host defence. Whilst this may in part be true, other biological functions of immune cells can also be compromised, such as that of cell-cell synapse formation and effector responses. Clearly, whilst integrins are important for cellular motility, their repertoire of functions extends far beyond the simple notion of being a sticky molecule on the surface of cells. The functions of integrins, beyond adhesion and migration, are not reviewed in any depth here, but nevertheless play integral roles in immune cell biology (von Andrian and Mackay 2000, Abram and Lowell 2007, Zhang and Wang 2012)

1.17 The role of adhesion and migration in T cell responses

β 2 integrins are implicated in at least two fundamental T cell activities involving adhesion and migration. LFA-1 in particular has been shown to be important for the arrest and migration of T cells under shear flow, and for the formation of an immunological synapse when T cells make contact with other cell types such as professional antigen presenting cells (Springer 1993, von Andrian and Arfors 1993, Springer 1994, Springer 1995, von Andrian and Mackay 2000, Dustin 2009). Here, I review what is known about integrin structure, function and regulation with particular emphasis on migration.

A simple paradigm exists regarding the ability of immune cells to preserve the host. In order to do so, cells must be mobile, they must localise to tissues where their function is required and they must rendezvous with other immune cells to relay information to each other to coordinate a response and they must avoid destruction/collateral damage of the host. The correct spatial arrangement of these cells in the body is therefore an absolute prerequisite for optimal function of the immune system. Traditionally, T cells have been thought of as being born in the bone marrow and educated in the thymus, after which they exit into the periphery where they recirculate through the blood, tissue and lymphoid organs (Butcher 1991, Springer 1993, von Andrian and Arfors 1993, Springer 1994, Springer 1995, von Andrian and Mackay 2000, Cyster 2003, Evans, Patzak et al. 2009). Upon entering lymph nodes, T cells encounter antigen presenting cells that can enable an effector programme within a T cell if the correct peptide loaded MHC is encountered by a peptide specific T cell receptor (Miller, Wei et al. 2002, Wei, Miller et al. 2002, Mempel, Henrickson et al. 2004). Already, two fundamental integrin functions become apparent from this simple paradigm; that of cellular mobility and that of cell-cell interactions (or T cell sampling of the APC/antigenic repertoire) required for immune cell activation.

1.18 What controls integrin activation?

T cells mainly arrest at postcapillary venules at sites of infection or injury and on high endothelial venules in lymph nodes (Tanaka, Umemoto et al. 2006). The arresting process is initiated by conformational changes in the integrin which facilitate/greatly enhance binding to its counterligand. For LFA-1, crystallographic studies have identified at least 3 conformations that are thought to reflect different stages of activation (Luo, Carman et al. 2007). These different conformations can be detected through the use of specific antibodies that recognise cryptic epitopes that are exposed when a conformational change occurs in LFA-1; these epitopes are associated with bent/low, intermediate and high binding affinities of integrin (figure 1.6). The $\beta 2$ integrins are found primarily in a bent conformation that does not favour ligand binding. Upon stimulation through other receptors, such as the selectins, chemokines and the TCR, the bent integrin conformation becomes extended allowing for ligand binding within 0.4 seconds of the initial activation signal (Shamri, Grabovsky et al. 2005) (von Andrian and Arfors 1993). During extension, the integrin transmembrane domain and cytoplasmic tails undergo rearrangement which may in turn allow LFA-1 conformations to be stabilised through interactions with scaffolding proteins, adaptors and enzymes within the cell (Kinashi 2005). Once extended, the integrin can bind to counterligand, after which further conformational changes ensue leading to high affinity and full extension of LFA-1. Although the precise mechanism governing this switch is unclear, it has been proposed that mechanical force may drive allosteric changes in integrin conformation, which in leukocytes might be provided by the shear force of blood flowing across the T cell membrane (Alon and Dustin 2007). An interesting study demonstrating this phenomenon by applying force to ligand bound $\alpha\beta 3$ indicated changes in high affinity binding that occurred in the order of nanoseconds (Puklin-Faucher, Gao et al. 2006). One might expect that for LFA-1, a similar mechanism might exist, but such a

mechanism remains to be fully evaluated in a more physiologically relevant experimental system.

The signalling events leading up to the conformational changes of T cell integrins in response to the interception of extracellular cues have only emerged in recent years. Given that integrins exist mainly in an inactive state on circulating leukocytes, an environmental cue must be intercepted leading to integrin activation, a process commonly known as “inside out” signalling. Once activated and bound to ligand, an “outside-in” signal that is transduced directly through the integrin itself is initiated. This leads to integrin clustering and changes in cell morphology, amongst many other programmes. It should be appreciated that a considerable amount of overlap appears to exist between the two signalling pathways, making the relative endpoint contribution of each cascade difficult to interpret.

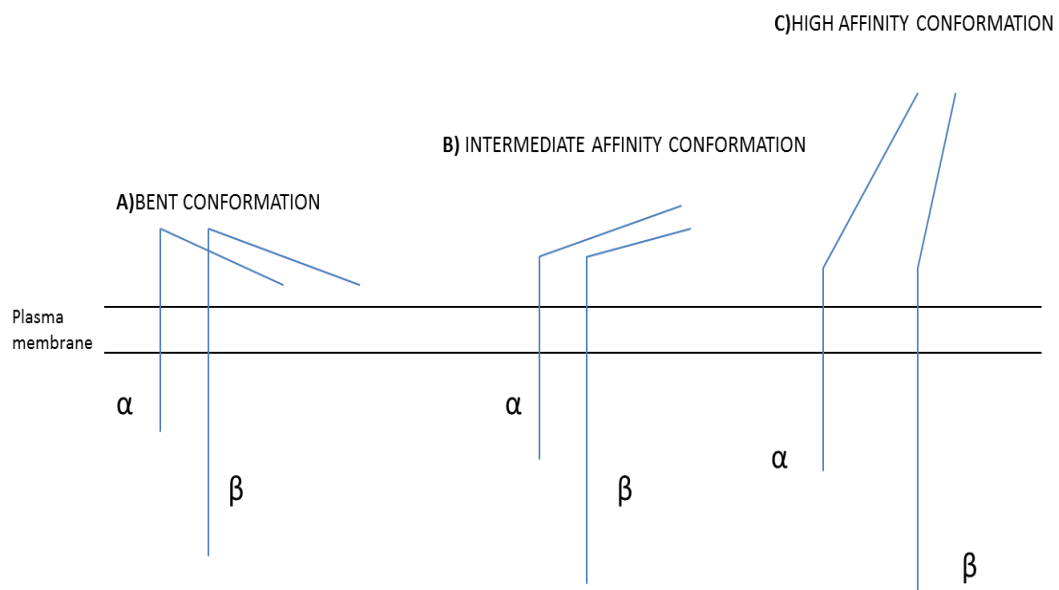

Figure 1.6 Conformational plasticity of LFA-1

Integrins can change conformation at the surface of the cell when an inside-out signal is intercepted and when counter-ligand is engaged (discussed further later). For LFA-1, at least 3 conformations have been reported to exist.

- A) In resting T cells, LFA-1 is in a bent conformation with the extracellular domain unable to engage ligand efficiently. The α and β chain are held together by a clasp.
- B) Following an inside-out signal (through chemokine or TCR for example) the extracellular domain of the integrin is oriented away from the membrane which allows for efficient binding of counter-ligand.
- C) Spatial changes within the transmembrane region of the α and β chain lead to the “kicking apart” of the integrin chains leading to an extended high affinity integrin that can bind with high efficiency to ligand through exposure of the extracellular domain. This conformation can be induced by ligand engagement, allowing strong adhesion and catch bonds to be formed.

1.19 Inside-out signalling leading to integrin activation

The engagement of receptors at the surface of cells leading to integrin activation is termed inside-out signalling (Fig 1.7). Given that the most well studied inside-out signals are in the context of G-protein coupled receptors forming the chemokine receptor family and the antigen T cell receptor, the focus here will be on how these two signalling pathways are able to control integrin activation when engaged.

Chemokines can be tethered to sulphated proteoglycans on the surface of cells or they can form a diffusible gradient in the extracellular space (Parish 2006, Schumann, Lammermann et al. 2010). On T cells, chemokine receptors, once engaged by their respective chemokine, promote changes in integrin conformation as well as changes in their ability to migrate directionally (Shamri, Grabovsky et al. 2005). Chemokine and antigen receptors, once engaged, activate guanine nucleotide exchange factors (GEFS) leading ultimately to RAP1 activation (Katagiri, Maeda et al. 2003, Shimonaka, Katagiri et al. 2003). Other important regulators participating in the inside-out pathway include talin, Kindlin-III and phosphatidylinositol-4-phosphate-5kinase type 1 γ 87, which will be discussed later in the chapter.

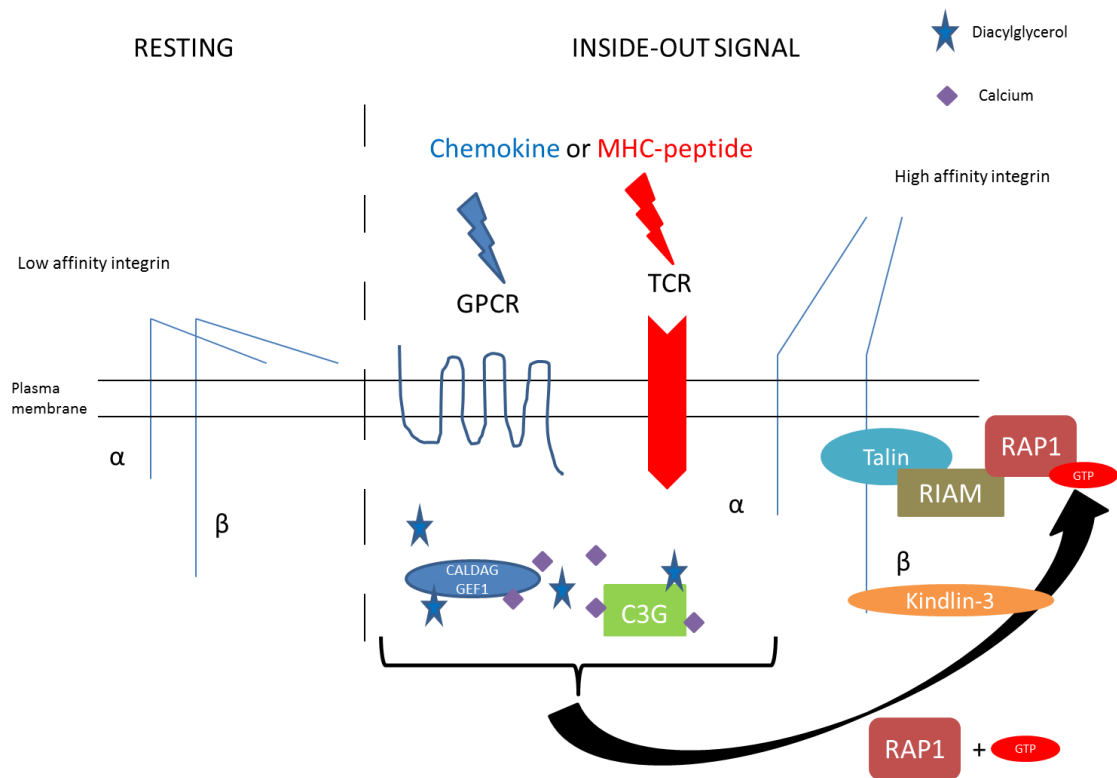

Figure 1.7 Inside-out signalling resulting in integrin activation

The engagement of receptors other than the integrin itself, like chemokines, selectins and antigen receptors, results in the binding of calcium and diacylglycerol to guanine exchange factors like CalDAG-GEF1 or C3G which in turn acts on RAP1 by exchanging GDP for GTP in haematopoietic cells. RAP1 then localises at the cell membrane and associates with adaptor protein RIAM. Talin is then recruited to and binds an NPXY motif located on the cytoplasmic tail of integrins, a process that appears to be greatly facilitated by kindlin-III binding, stabilising high affinity conformations.

The control of RAP1 guanine exchange factors

RAP1 activation requires the exchange of inactive GDP bound RAP1 to active GTP bound RAP1, and this process in T cells is thought to be controlled through at least two guanine exchange factors (GEFS) known as C3G (RAPGEF1) and CALDAG-GEF1 (calcium and diacylglycerol-regulated guanine nucleotide exchange factor 1). Both of these exchange factors are activated in response to phospholipase C activation which generates diacylglycerol, which in turn directly modulates GEF activity, or through the generation of inositol triphosphate (IP3) that binds to IP3 receptors on the endoplasmic reticulum releasing calcium ions. Calcium mobilisation can also potentiate GEF exchange activity

Primary human T blasts where CALDAG-GEF1 is silenced displayed impaired adhesion to ICAM-1 (Ghandour, Cullere et al. 2007). In addition, CALDAG-GEF1 deficient murine cells display impaired adhesion in both platelets and neutrophils, a finding that was associated with impaired RAP1 activation (Crittenden, Bergmeier et al. 2004, Bergmeier, Goerge et al. 2007). CALDAG-GEF1 knockout mice are considered a model for LAD-III patients because individuals who present with the disease have a mutation in CALDAG-GEF1 that disrupts the splicing of this gene (Pavolsky, Feigelson et al. 2007). More recently, whole exome sequencing of humans identified a CALDAG-GEF1 mutation that impairs platelet spreading and adhesion, although the defects observed as a result of this mutation did not alter leukocyte biology (Canault, Ghalloussi et al. 2014). This could have been due to the mutation being inconsequential on the integrin function studied in leukocytes, rather than CALDAG-GEF1 not being important in leukocyte integrin biology. Thus, CALDAG-GEF1 represents an important candidate that regulates integrin conformation when chemokines engage their respective ligands through direct exchange activity on RAP1.

C3G, on the other hand, is thought to be activated primarily downstream of the antigen receptors and forms a complex with CRKL. Silencing of either C3G or CRKL leads to impaired

adhesion of T cells to ICAM-1 or fibronectin following TCR stimulation (Nolz, Gomez et al. 2006). Conversely, overexpression of C3G potentiates the binding of integrin following TCR stimulation, firmly establishing C3G as an important regulator of the capacity of integrin to bind to its counterligand following TCR engagement. Together these results strongly suggest that this exchange factor complex operates upstream of both $\beta 2$ and $\beta 1$ integrin activation.

RAP1 activation can also be activated through protein kinase C (PKC), which responds to rises in intracellular Ca^{2+} and DAG (Han, Lim et al. 2006). At this point the kinetic of RAP1 activation may be relevant, in that PKC activation via the TCR leads to slower, more sustained activation of RAP1, which might be consistent with activation of a large subset of integrins whose role is then to form strong adhesive contacts between two cells, as is the case for immune synapse formation (Dustin, Bromley et al. 1997, Katagiri, Shimonaka et al. 2004). A paper that compares RAP1 activation via PKC or CALDAG-GEF1 reports a difference in kinetic of RAP1 activation and might reflect the differential requirement of fast versus sustained activation in platelets (Cifuni, Wagner et al. 2008). Thus, different exchange factors may come into play depending on the requirement of how long integrins stay in a given conformation and the amount of activated integrin that can bind to counterligand, making receptor-ligand interactions more or less likely. There are some integrin activation modules that supposedly completely bypass RAP1 activation and rely instead on a PKC dependent RAP1 independent signalling module (Ghandour, Cullere et al. 2007). Others have reported conflicting data, suggesting that a RAP1 inhibitor abolishes adhesion through all integrins tested (Shimonaka, Katagiri et al. 2003). What then is the contribution of RAP1 to inside-out signalling?

RAP1 as an activator of LFA-1

The importance of RAP1 in LFA-1 biology is demonstrated by the following experimental evidence;

1) Expression of constitutively active RAP1 enhances the capacity of T cells to migrate and form conjugates with APCs (Sebzda, Bracke et al. 2002)

2) Dominant negative forms of RAP1 display the opposite effect of a constitutively active RAP1 which was further verified through knockdown experiments, GAP overexpression and RAP1 inhibition (Katagiri, Hattori et al. 2000). The convergence of various receptor pathways on RAP1 leading to integrin activation for LFA-1 at least, is clear.

RAP1 has recently been postulated to be transported in vesicles to the plasma membrane with LFA-1. A C-terminal CAAL motif (cysteine-aliphatic-aliphatic-leucine) is irreversibly modified by a geranyl-geranyl lipid group such that the protein is targeted to membranes in both the intracellular lipid compartment, which might include vesicles, and the plasma membrane. Vesicles containing RAP1 are delivered to the plasma membrane in T cells (Bivona, Wiener et al. 2004, Mor, Wynne et al. 2009), although it is unclear whether this is a constitutive process or that governed by GPCR or TCR stimulation. These vesicles are positive for early and late endosomal markers, suggestive of a recycling pathway. Indeed, delivery of RAP1 can be antagonised by specifically blocking RAB11, presumably by inhibiting the delivery of vesicles to the membrane or inhibiting docking of vesicle at the plasma membrane (Katagiri, Maeda et al. 2003, Bivona, Wiener et al. 2004, Mor, Wynne et al. 2009, Raab, Wang et al. 2010). The question of the status of RAP1 activation within vesicles is beginning to be addressed: Does RAP1 arrive at the membrane in pre-assembled signalling platforms within vesicles that do not require further activation or does activation of RAP1 occur at the membrane? A biosensor that monitors RAP1 activity showed reporter activity only in the leading membrane ruffles of TCR stimulated Jurkat T cells, indicating RAP1 activation is occurring dynamically at the membrane (Bivona, Wiener et al. 2004, Mor, Wynne et al. 2009). Primary cell experiments involving the use of chemokine suggested that active RAP1 is required within vesicles if LFA-1 is to be delivered appropriately to the leading edge membrane (Katagiri, Maeda et al. 2003). It is not completely unfeasible that when comparing TCR to chemokine stimulations, the signal

requirements of vesicular versus non-vesicular GTP-bound RAP1 is different, which might reconcile these two disparate findings.

Vesicles containing RAP1 also cargo its downstream effectors, RAPL and MST1. LFA-1 delivery to the leading edge of the plasma membrane and to the pSMAC during synapse formation has been shown to be dependent on RAPL (Katagiri, Maeda et al. 2003, Kliche, Breitling et al. 2006). The serine/threonine kinase MST1 interacts with RAPL via its coiled coil domain. The exact function of MST1 has yet to be identified in the context of LFA-1 containing vesicles, with no target phosphorylation sites on LFA-1 itself being identified. Many different versions of the core module, in addition to the RAP1-RAPL-MST exist, with RAP1-RIAM-SKAP55-ADAP or RAP1-RAPL-SKAP55-ADAP also appearing to be detectable within vesicles (Kliche, Breitling et al. 2006, Menasche, Kliche et al. 2007, Raab, Wang et al. 2010). Exactly how these proteins interact within vesicles and following the docking of vesicles onto the plasma membrane is the subject of an emerging field that is investigating integrin trafficking and signalling by a vesicular transport system.

The final steps of inside-out signalling

Clearly a complex set of molecular interactions occurs when inside-out signalling is initiated. The final steps of inside-out signalling have been hard to study because once the integrin is activated, and binds to its ligand, outside-in signalling is initiated. This makes it difficult to disentangle the relative contribution of signalling originating from other receptors and signalling that originates specifically from the integrin itself. The conversion of intermediate to high affinity LFA-1 has been shown to be dependent PIP5K1 γ 87, which phosphorylates lipid groups allowing for the recruitment of pleckstrin homology domain containing proteins via a phosphatidyl inositol-4-5 bisphosphate dock. TCR and chemokine receptors have been shown to be upstream of phospholipase D activation which generates phosphatidic acid that stimulates PIP5K1 γ 87 activity upstream of integrin activation. The generation of phosphatidyl

inositol-4-5 bisphosphate has been shown to be important for talin recruitment by virtue of four positively charged lysine residues that interact with phosphoinositides (Martel, Racaud-Sultan et al. 2001). Talin is a cytoskeletal adaptor that links the cytoplasmic tails of integrins to the actin cytoskeleton, stabilising high affinity integrin conformation (Ulmer, Calderwood et al. 2003). The discovery of Kindlin-III as a haematopoietic cell specific integrin activator that might facilitate talin recruitment is also a recent development (Moser, Nieswandt et al. 2008, Moser, Bauer et al. 2009). This protein has been of particular interest due to mutations in humans causing LAD-III (Malinin, Zhang et al. 2009, Svensson, Howarth et al. 2009). T cells from LAD-III patients do not change integrin conformation upon chemokine stimulation or with phorbol esters which directly activate PKC (upstream of RAP1 activation) (Manevich-Mendelson, Feigelson et al. 2009). Thus, it appears that kindlin-III is an important regulator of inside-out signalling.

1.20 Outside-in signalling

Once engaged, integrins signal back into the cell, the identifiable consequence of which appears to be adhesion strengthening and cell effector responses. In contrast to inside-out signalling, very little is known about outside-in signalling in T cells. It is most likely that the outside-in and inside-out pathways cooperate during signal transduction with some overlapping and some distinct features attributable to each pathway. Here I review the literature on outside-in signalling in platelets and immune cells.

Platelets as a model system for outside-in signalling

The role of the Src and Syk family kinases in platelet outside-in signalling has been well studied (de Virgilio, Kiosses et al. 2004). Resting platelets show constitutive association of integrin $\alpha\text{IIb}\beta\text{3}$ with Src, which is in turn thought to be controlled through its association with Csk, maintaining Src in a closed “off” position, masking the SH2 and SH3 domains from interaction with other proteins. The binding of fibrinogen to $\alpha\text{IIb}\beta\text{3}$ leads to the dissociation of Csk from Src and the dephosphorylation of an inhibitory tyrosine that is located in the C-terminus of Src leading to autophosphorylation at the activatory loop of the kinase domain (Arias-Salgado, Lizano et al. 2003). Syk is then recruited to the integrin and phosphorylated by Src (Gao, Zoller et al. 1997). Syk is then thought to phosphorylate downstream effectors like Vav1/3 and the adaptor protein SLP-76 (Oberfell, Judd et al. 2001, Bezman, Lian et al. 2008). Activation of Vav is a key event governing cytoskeletal changes leading to platelet spreading through the activation of elements involved in remodelling the cytoskeleton. Deletion of Syk in platelets leads to the inability of platelets to spread on fibrinogen. Studies in chinese hamster ovary (CHO) cells suggested that Syk is directly associated with β3 in a phosphotyrosine independent manner, which might imply that the tandem SH2 domain is dispensable for the association of Syk with β integrin tails (Woodside, Oberfell et al. 2002). The requirement of the SH2 domain of Syk will be discussed further in the next section.

Outside-in signalling in immune cells

Immune cells utilise Src and Syk family kinase members to signal through integrins in a similar way to platelets. The use of various Src family kinase members as initiators of outside-in signalling is clear, but the molecular events following Src activation are less clear (Ginsberg, Partridge et al. 2005, Giagulli, Ottoboni et al. 2006, Totani, Piccoli et al. 2006, Evangelista, Pamuklar et al. 2007, Evans, Lellouch et al. 2011, Cimo, Ahmed et al. 2013). Here I review the activation of Syk by Src in myeloid cells and neutrophils as the majority of outside-in literature has centred on these cells, and so at least some similarities could exist with T cell outside-in signalling, as discussed afterward.

Outside-in signalling initiates Src recruitment and/or activation and subsequent Syk phosphorylation (fig 1.8). It was shown using retroviral reconstitution of platelets and myeloid cells with Syk lacking functional SH2 domains, that localisation of Syk to signalling complexes at the membrane was compromised as compared to wild type Syk (Abtahian, Bezman et al. 2006, Mocsai, Abram et al. 2006). Subsequently, adaptors containing ITAM motifs like Fc γ R-chain receptor and DAP12 have been shown to be important for integrin signalling to proceed, by recruiting Syk. Deletion of these adaptors leads to integrin signalling failure (Mocsai, Abram et al. 2006).

Neutrophils and macrophages signal through β 2 integrins leading to adhesion strengthening, spreading, chemotaxis, ROS production and the release of cytokines and cytotoxic granules. (Mocsai, Zhou et al. 2002). Neutrophils derived from human individuals and mice that lack β 2 integrins are unable to mount any of the aforementioned responses when plated on ICAM-1 (Abram and Lowell 2007). The requirement for adaptors like Fc γ R-chain and DAP12 for integrin signalling was extended from myeloid cells to neutrophils in these studies. Thus adaptors may be a universal feature of integrin signalling in immune cells through the β 2 family of integrins.

The engagement of $\beta 2$ integrin leads to the recruitment of activated Src which in turn phosphorylates membrane associated adaptor molecules like Fc γ R-chain and DAP12 at two critical tyrosine residues within ITAM motifs. This phosphorylated motif recruits Syk by virtue of its SH2 domains, and Syk is then phosphorylated and activated by Src.

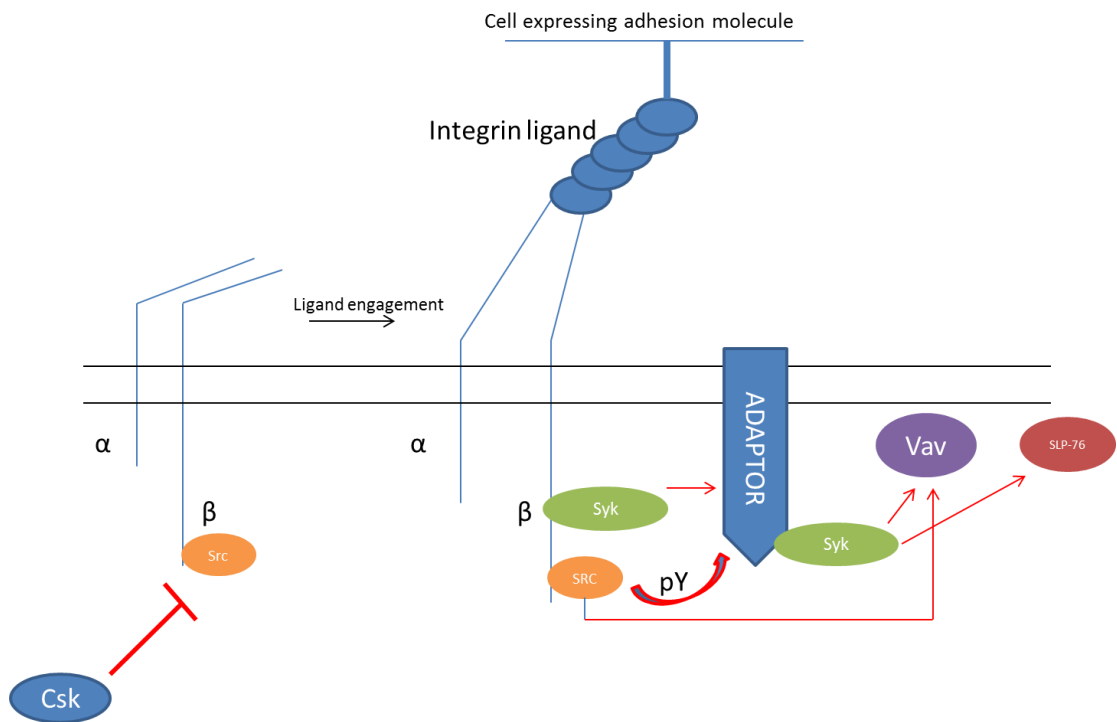

Figure 1.8 Integrin mediated outside-in signalling

Un-engaged integrin is constitutively associated with Src which is maintained in an inactive conformation by Csk. Following ligation by counterligand, Csk dissociates allowing for the dephosphorylation of Src at an inhibitory residue (candidates include CD45 and PTP1B) at which point Src autophosphorylates at the activatory loop within the kinase domain. Activated Src can then phosphorylate various proteins, involved in signal transduction, which in myeloid and granulocytes includes DAP12 and FcRγ chain (denoted by the adaptor). In these cells, the adaptor proteins have been postulated to recruit Syk via the ITAM motifs, which in turn may activate SLP76 and VAV. The consequence of the cellular programme that occurs following the engagement of integrin is not well studied, but might include cell spreading, ROS production, cytokine production and adhesion under flow. The signalling pathways are not clear here, and

will be discussed further in light of the data collected in this project in the final discussion with specific reference to integrin signalling in T cells.

Curiously, protein-protein interaction studies have failed to demonstrate a physical interaction between $\beta 2$ and adaptor molecules like Fc γ R-chain receptor and DAP12, or indeed any other ITAM containing adaptor. Either the interaction is weak and not detectable, or these adaptors somehow localise proximally to integrin, possibly through remodelling of plasma membrane microdomains (Jakus, Fodor et al. 2007). Alternatively, Syk may be activated at the integrin and then is retained at the plasma membrane through the association with adaptor molecules.

Retroviral reconstitution of neutrophils and macrophages with wild type and mutant Syk or DAP12 pointed to an important function of these molecules during integrin signal transduction, leading to cell spreading, degranulation and reactive oxygen intermediate production. Surprisingly, however, migration was not reported as defective in any of the first studies published with regard Syk and DAP12 reconstitution experiments (Mocsai, Zhou et al. 2002, Mocsai, Zhang et al. 2003, Mocsai, Abram et al. 2006). Contrary to these reports, recent work has reported migratory defects in Syk knockout neutrophil cell lines and primary Syk knockout neutrophils (Schymeinsky, Then et al. 2005, Schymeinsky, Sindrilaru et al. 2006, Frommhold, Mannigel et al. 2007). In the neutrophil cell line, wild type Syk-GFP fusion proteins localised to the lamellapodia at the leading edge of the cell, whereas mutant Syk-GFP lacking the two tandem SH2 domains showed no obvious localisation. In contrast to the wild type construct, the mutant Syk cells formed multiple lamellopodia impeding their ability to migrate. Mice in which Syk was knocked out of neutrophils demonstrated that neutrophil influx into inflamed tissue was compromised if Syk was not expressed (Frommhold, Mannigel et al. 2007). More data from different labs is required in order to reconcile these different findings. It is clear however, that Syk is playing some role in regulating outside-in signalling, which may be cell specific, or otherwise not identified.

What then might the outside-in signalling module in T cells look like? In T cells, ZAP-70 is expressed instead of Syk, but the domain structure of ZAP-70 is identical to Syk. The difference is that ZAP-70 has many more regulatory features, which would be in keeping with its function

as a gatekeeper of adaptive immunity, and must therefore be highly regulatable to avoid inappropriate T and B cell activation (Wang, Kadlecik et al. 2010). Two Src family kinases are predominantly expressed in T cells, Lck and Fyn. By taking a systematic approach, the Hogg lab investigated the ability of Src family kinase members in primary T cells to bind to LFA-1 (Evans, Lellouch et al. 2011). In these studies they found that only Fyn and Lck were expressed at appreciable levels as compared to other Src family kinase members, and that Lck could be found associated with LFA-1. In this same study, it was shown that a hierarchy existed in terms of the activation of Lck and ZAP-70, in that Lck is responsible for ZAP-70 phosphorylation. Treatment of cells with the small molecule inhibitor PP2, which inhibits Lck, abolished ZAP-70 phosphorylation; this correlated with an inability of T cells to migrate. Lck knockdown in primary T cells phenocopied the inhibition of Lck with PP2, where, upon ICAM-1 contact, the cells were rounded and did not polarise or migrate.

Further studies using ZAP-70 inhibitors and ZAP-70 knockdown strategies demonstrated that T cells are unable to migrate when ZAP-70 is not functional or absent. Confocal studies demonstrated that ZAP-70 co-localised with high affinity integrin as detected by mab24, leading the authors to postulate that ZAP-70 may in some way be involved in the transition of intermediate affinity integrin to high affinity integrin, because knockdown and inhibition studies led to no differences in intermediate affinity LFA-1 but a large reduction in high affinity LFA-1. What is particularly interesting about these studies is that ZAP-70 phosphorylation preceded the association of talin with the β chain of LFA-1, suggesting that perhaps ZAP-70 may in some way facilitate talin-integrin association. Further studies are needed to understand a direct causal link between ZAP-70 activation and the recruitment of talin to LFA-1. Interestingly, a study by Garcia-Bernal in 2006 proposed that ZAP-70 can phosphorylate an integrin associated Vav-Talin complex, leading to its dissociation and talin binding to integrin stabilising the high affinity conformation (Garcia-Bernal, Parmo-Cabanas et al. 2009). The dissociation of the Vav-talin complex through ZAP-70 dependant phosphorylation of Vav, releasing talin such that it can bind integrin, was, in this study, mediated by chemokine

engagement, making it hard to understand the relative contributions of chemokine signalling and integrin engagement. These observations demonstrate cross-talk between outside-in and inside-out signalling, and the difficulty in studying such processes, as these two different receptor mediated pathways appear to utilise the same signalling intermediates, and it is currently unknown if the endpoint of each of these pathways converge when co-stimulated *in vivo*.

The most recent and comprehensive study describing how signalling intermediates participate in integrin dependant outside-in signalling, as opposed to TCR dependant inside-out signalling, were performed by the Ladbury lab (Cimo, Ahmed et al. 2013). This study proposed that ZAP-70 undertakes a scaffolding function in integrin signalling, and that the catalytic activity of ZAP-70 is not required, as demonstrated by a lack of Y493 phosphorylation within the activation loop of the kinase domain. In contrast, T cell receptor signalling is absolutely dependent on the catalytic activity of ZAP-70. It was further demonstrated that integrin stimulations in ZAP-70 deficient Jurkat T cells, led to Vav and LAT phosphorylation, which contrasted with TCR stimulations where LAT and Vav were not phosphorylated in the absence of ZAP-70. Furthermore, SLP-76 was phosphorylated on at least two tyrosine residues in response to integrin ligation, but was dispensible for Vav phosphorylation. This is not the case for TCR signalling where the absence of SLP76 impairs Vav phosphorylation by inhibiting its recruitment and phosphorylation of LAT. In addition to these findings, it was reported that a non-canonical MAP kinase pathway involving a RAP1-BRAF-MEK-ERK rather than a RAS-RAF-MEK-ERK module was utilised by integrin as seen when stimulating through the TCR. Furthermore, this non-canonical pathway relied only on Lck and not ZAP-70, VAV, LAT or SLP-76 to activate ERK. This study demonstrated that whilst many signalling components are common to both the TCR and integrin, there appears to be differences in terms of the hierarchical activation signalling intermediates in response to different receptors.

1.21 Negative regulators of integrin signalling

Integrins must be able to switch between active and inactive states in order to fulfil their functions. Interestingly, a mutation in mice leading to constitutively active LFA-1 phenocopies knocking out LFA-1, suggesting that both over activation and deficient LFA-1 T cells lack motility (Park, Peixoto et al. 2010). There is a distinct lack of literature describing how integrins inactivate, and instead most of the integrin literature has focused on activation. The few documented negative regulators of integrin function include: RhoH, which is thought to interfere with RAP1 activation (Cherry, Li et al. 2004); CDC42 which in some way interferes with high affinity conversion of integrin (Bolomini-Vittori, Montresor et al. 2009); CBL-B, an E3 ubiquitin ligase that inhibits the exchange activity of C3G-CRKL on RAP1 and finally the protease calpain which is thought to “clip” the head domain of talin leading to destabilisation of conformation and subsequent release of integrin-ligand interactions (Zhang, Shao et al. 2003). DOK proteins are also thought to be important regulators of integrin function by binding to phosphorylation sites on the integrin chains. These sites are phosphorylated on resting integrins and it is thought that the binding of DOK to these phosphorylation sites inhibits the recruitment of talin (Guittard, Gerard et al. 2009).

That phosphorylation is such an important facet of integrin signalling, I hypothesise the existence of phosphatases antagonising the action of kinases at virtually every phase of integrin function. One candidate phosphatase regulating Src and Syk family kinases is PTPN22. Thus I hypothesise that PTPN22 may in some way regulate outside-in signalling mediated by Src and Syk family kinases in T cells.

1.22 Project Aim

PTPN22/Lyp has been shown to interact with Lck, ZAP-70 and Vav, all of which form part of the T cell receptor signalling cascade. This project aims to understand whether or not, in addition to the T cell receptor, Lyp regulates Lck, ZAP-70 and Vav downstream of integrin outside-in signalling. I approach this question using many different experimental techniques adopting functional, biochemical and visual readouts. It was the intention from the outset to broaden the understanding of how outside-in signalling proceeds in T cells, whilst providing some insight into how genetic variants of Lyp leads to differences in cell behaviour with respect to adhesion and migration.

Chapter 2
Materials and Methods

2.1 Molecular biology

2.1.1 Molecular biology reagents

REAGENT	WORKING CONCENTRATION	SOURCE
Electrophoresis grade agarose	1-2% w/v	Invitrogen UK
Ethidium bromide	0.5µg/mL	Sigma
Restriction enzymes	As indicated (or according to instructions)	New England Biolabs
DNA T4 ligase	As indicated (or according to instructions)	New England Biolabs
PFU ultra II hotstart	As indicated (or according to instructions)	Stratagene
LB agar	15g/L	Invitrogen UK
LB broth	25g/L	Invitrogen UK
Ampicillin	50µg/mL	Sigma
Kanamycin	40µg/mL	Sigma

2.1.2 DNA/RNA isolation, reverse transcription, plasmid isolation and gel purification

Qiagen kits were used according to the manufacturer's protocol.

2.1.2.1 DNA precipitation

A step-wise protocol was optimised for DNA precipitation, as follows:

1. Add 1/10 volume of sodium acetate (3 M, pH 5.2).
2. Add 2.5–3.0 X volume (calculated after addition of sodium acetate) of at least 95% ethanol.
3. Incubate on ice for 15 minutes. In case of small DNA fragments or high dilutions overnight incubation gives best results, incubation below 0°C does not significantly improve efficiency.
4. Centrifuge at > 14,000 x g for 30 minutes at room temperature or 4°C.
5. Discard supernatant being careful not to throw out DNA pellet which may or may not be visible.
6. Rinse with 70% Ethanol.
7. Centrifuge again for 15 minutes.
8. Discard supernatant and dissolve pellet in the desired buffer. Make sure the buffer comes into contact with the whole surface of the tube since a significant portion of DNA may be deposited on the walls of the Eppendorf instead of in the pellet.

2.1.2.2 DNA ligations

The following protocol was adopted to perform DNA ligations:

1. Gel purify amplicons from PCR reaction and cut using appropriate restriction enzymes, or cut insert directly from plasmid.
2. Prepare plasmid by cutting at appropriate restriction sites.
3. Prepare various ratios of insert to vector (1:1, 2:1, 3:1) or use the following equation to optimise ligations: $\text{ng insert} = \text{ng vector} \times \text{Kbp} / \text{Kbp vector}$.
4. Add appropriate amount of quantified vector and insert, make up to 17 μ L with ddH₂O.
5. Add 2 μ L 10X ligase buffer and 1 μ L T4 DNA ligase.
6. Incubate overnight at 4°C or 1h at room temperature (RT).
7. Transform home-made super competent XL-Blue bacteria.

2.1.2.3 Preparation of competent cells

XL-Blue super competent cells were generated using a rubidium chloride protocol, briefly described as follows.

TFB1	Concentration	MW
Rubidium Chloride	100 mM	120.92
Manganese Chloride (MnCl ₂ H ₂ O)	50 mM	197.91
Potassium Acetate	30 mM	98.14
Calcium Chloride (CaCl ₂ H ₂ O)	10 mM	147.02
Glycerol	15%	

Adjust to pH 5.8 with dilute (0.2%; 1.0 M) acetic acid. Filter sterilise. Store at RT. Bring to 4°C before use

TFB2	Concentration	MW
MOPS	10 mM	209.3
Rubidium Chloride	10 mM	120.92
Calcium Chloride	75 mM	147.02
Glycerol	15%	

Adjust pH to 6.5 with KOH. Filter sterilize. Store at RT. Bring to 4°C before use.

- 2X YT media
- 16 g Bacto tryptone
- 10 g Bacto yeast extract
- 5g NaCl

Add 900 mL water and adjust to pH 7.0 with 5N NaOH.

Bring up to 1000mL and autoclave.

Step 1: Bacterial Culture

1. Plate XL-Blue onto tetracycline containing LB agar plate.
2. Inoculate single colony into starter culture of 20 mL SOC media in 125mL Erlenmyer flask
3. Incubate overnight in 30°C or in a 37°C shaker.
4. Inoculate growth culture 1:100 with starter culture. Put in 37°C shaker.
5. Grow until OD600 reaches 0.4-0.6 (~5h)
6. After this point, **keep everything cold**. Work in cold room and pre-chill all supplies.

Step 2: Priming competent bacteria using TFB1 and TFBII

1. Transfer bacteria to culture flasks and spin down. 5000 x g, 4°C, 10 mins.
2. Pour out supernatant.
3. Gently rinse flasks and pellet with small aliquot of TFB1 to remove all traces of media.
4. Add 100 mL TFB1 per 250 mL of growth culture and resuspend using 10ml serological pipette.
5. Incubate in wet ice for 5 minutes.
6. Spin down 5000 x g, at 4°C for 5 mins.
7. Remove all supernatant.
8. Add 10 mL TFB2 per 250 mL growth culture and gently resuspend by pipette.
9. Incubate on ice 15-60 mins.

Step 3: Snap freezing bacteria

Dispense 50 μ l into pre-chilled 1.5 mL microcentrifuge tubes and snap freeze in Liquid nitrogen.

Store at -80°C

1.3 Site directed mutagenesis

A pEF5HA-Lyp plasmid encoding wild type Lyp was kindly donated by the Bottini Lab (Figure 1). This plasmid was then sequenced to confirm its identity and used as a backbone to create Lyp mutants that had previously been reported in the literature . Primers were designed to complement the flanking regions of base pairs that were to be mutated, but the actual nucleotides that were mutated were changed within the primer sequence (Table 1). The middle of the primer was thus “uncomplimentary” containing a base pair (or base pairs) that corresponded to the mutant that was being generated. Following the engineering of the primers the PCR mixes were all run under the same programme.

Make PCR mix: final volume 20uL

- 0.5+0.5 μ L 10uM primers
- 10ng plasmid DNA
- 1uL 10mM dNTPs
- 2uL of 10X PFU buffer
- 0.5ul of Pfu (a high fidelity polymerase!) reliably clones up to 9kB plasmids
- 14.5 μ L DDH2O

PCR programme:

- 95°C for 2 mins
- 95°C 30sec
- 55°C 1 min
- 68°C 15 mins
- 25 cycles
- Add 1µL of DPN1 and incubate for 30 mins at 37°C

Importantly, I used a high fidelity polymerase called PFU that has the ability to “proofread” plasmids, copying up to 9kB of plasmid with 100% fidelity in most cases. In the final step, DPN1 was used to cleave any template containing methylated DNA that will have been bacterially replicated, rather than through amplification of DNA via a PCR, leaving only plasmids containing the mutated sites, which were then used to transform XL-BLUE competent cells generated in the laboratory. Transformed bacteria were then plated and single colonies were first screened by an in house PCR reaction to confirm transformation and the correct size amplicon within the right region. Cycle sequence technology (dideoxy chain termination, machine ID ABI3730XL) was used to confirm that the chosen plasmid contained no other mutations.

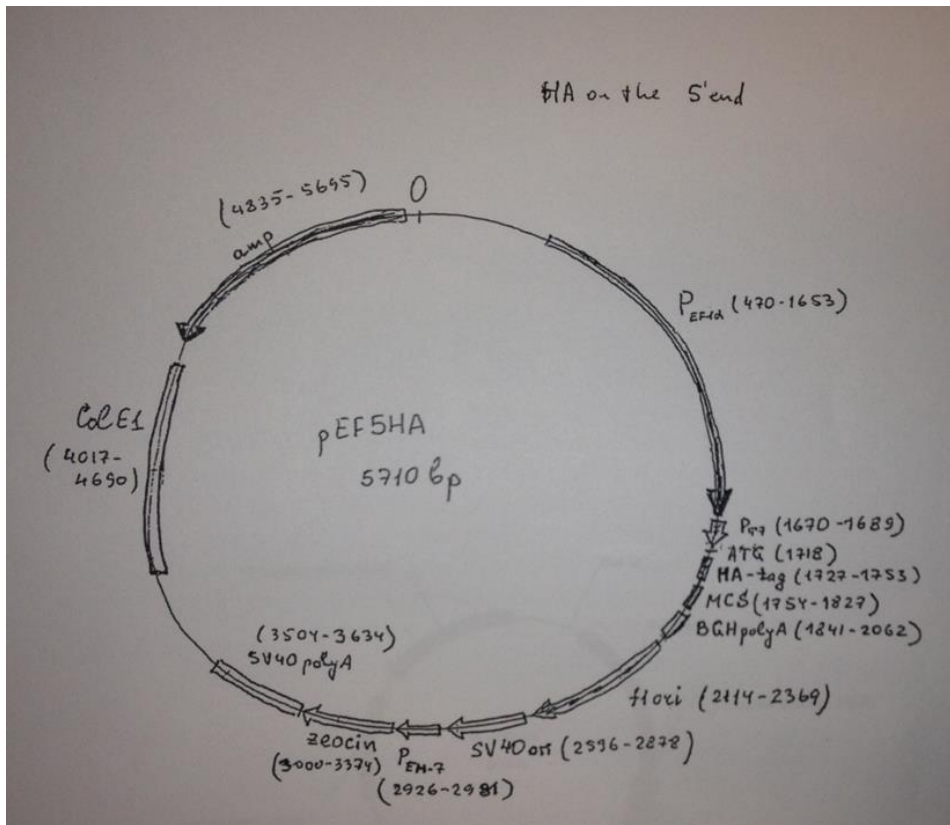

Figure 1: **Self annotated plasmid map of the pEF5HA plasmid.** The pEF5HA plasmid was used by the Bottini group to express Lyp. The plasmid included a zeocin cassette which can be used to create stably expressing Lyp transfectants. Ampicillin was used to select for positive colonies. Lyp was cloned into the multiple cloning site (XBA). The HA tag was ligated to the N terminal of Lyp in the catalytic domain.

Primer	Base change	Forward	Backward
S35E	Serine → Glutamic acid	CTGAAGCTGAA AAGGCAAGAA ACCAAGTACAA GGCAGAC	GTCTGCCTTGTA CTTGGTTTCTTG CCTTTTCAGCTT CAG
C227A	Cysteine → Alanine	TGTTCCCATATG CATTACGCCA GTGCTGGCTGT GGAAGGACTG G	CCAGTCCTTCC ACAGCCAGCAC TGGCGTGAATG CATATGGGAAC A
Y536F	Tyrosine → Phenylalanine	GTGGAAAATCC TTTTTTTTCATC ATGGCCTC	GAGGCCATGAT GAAAAAAAAG GATTTTCCAC
R620W	Arginine → Tryptophan	CCAATTCC TGTATGGACAC CTGAATC ATTTA	TAAATGATTCAG GTGTCCATACA GGAAGTGG

Table 1: Site Directed Mutagenesis. Primers used for site directed mutagenesis spanned the region of interest in the plasmid sequence and contained appropriate changes in base pairs leading to changes in protein sequence.

1.4 Preparation of Lyp-GFP fusion constructs

Lyp-GFP fusion proteins were generated by sub-cloning the Lyp insert from the pEF5HA plasmid into a pCS2PGFPx (kindly donated by Dr. Marc Dionne). The GFP was tagged to the C-terminus of the protein. XHO1 and XBA1 were used to cut the eGFP at the multiple cloning site and an insert sub-cloned from the pEF5HA-Lyp containing plasmid was amplified using primers with XHO1 and SPE1 overhangs. Importantly, the stop signal from the original plasmid was deleted, allowing the sequence to be read through, ultimately allowing the GFP to be expressed downstream of the Lyp protein sequence. The Lyp amplicon was then cut with Xho1 and Spe1 and ligated into the Xoh1 and Xba1 sites (Spe1 can ligate into Xba1). Bacteria were then transformed, colonies were picked and screened by PCR, and verified by dideoxy chain termination sequencing.

Strategy

This is the multiple cloning site from the eGFP vector.

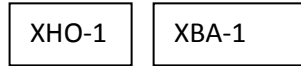

CGATT**CGAATTCAAGGCCTCTCGAGCCTCTAGAC**CATGGTGAGCAAGGGCGAGGAGCTG

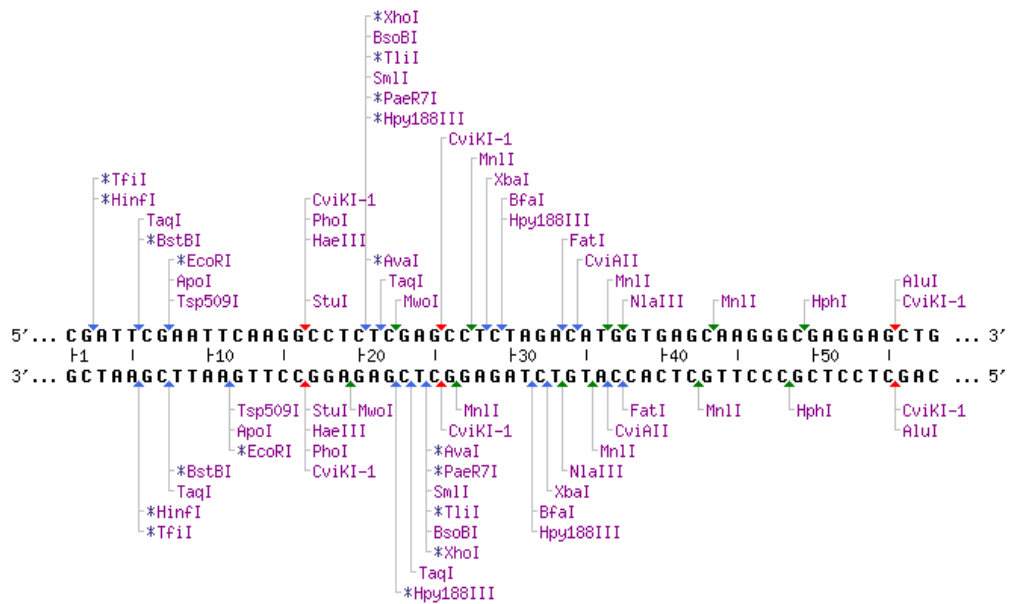

Forward sequence of *PTPN22* sequence in pEF5HA vector (current vector)

5'...ATGGGTACCTATCCTTACGACGTTCCAGACTATGCAGGATCC...3'

Add in a Xho1 restriction site:

5'... C[^]T C G A G ... 3'

3'... G A G C T_▲C ... 5'

Forward primer: ataatcCTCGAGATGGGTACCTATCCTTACGA

Backward sequence of PTPN22 in pEF5HA

3'...GACCAAGGAATCCACCACCAACTTGGGAATATTTAA...5'

Add in Spe1 restriction site

5'... A[^]CTAG T ... 3'

3'... T GATC_A ... 5'

Reverse backward:

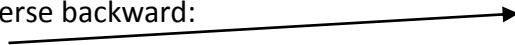

DELETE THE STOP CODON

TTAAATATTCCAAGTTGGTGGTGGATTTCCTTGGTC

2.1.5 Restriction Fragment Length Polymorphism (RFLP) for *PTPN22* genotyping

2.1.5.1 Polymerase Chain Reaction (PCR)

Primers specific for genotyping the *PTPN22* single nucleotide polymorphism rs2476601 (Forward; CAACTGCTCCAAGGATAGATG, Reverse; CTCAAGGCTCACACATCAGC) were resuspended in RNase free H₂O (Sigma), and aliquots stored at -80°C minimising 'freeze/thaw' cycles. Primers were firstly optimised for annealing temperature and MgCl₂ concentration, a cofactor for the Taq polymerase enzyme. A Taq PCR reaction was therefore performed using varied concentrations of MgCl₂ on a temperature gradient within a PCR machine. The below PCR mix was used with either 0.8 µl, 1.2 µl or 1.8 µl of 25mM MgCl₂ to a concentration of 1 mM, 2 mM or 3 mM and all were assessed in parallel with an annealing temperature gradient set on the Thermocycler (BioRad) between 55°C-65°C. PCR products 10 µL/well (3 µL of loading dye was added to each 15 µL PCR reaction) were the run on a 2% agarose gel (3g of agarose was dissolved in 150 mL Tris-Borate-EDTA (TBE)), and stained with 1 µL ethidium bromide which intercalates with nucleic acids. A 100 base pair ladder (New England Biolabs) was added to the gel in order to assess that the PCR product is the correct length. The voltage was then turned to 100 V and the gel left to run for ~1 hour. The gel was the scored following UV visualisation demonstrated that 1 µM MgCl₂ 55°C were optimal conditions for *PTPN22* genotyping.

Optimised PCR reaction:

- DNA (50 ng/ μ L)
- 0.075 μ L Forward Primer (100mM)
- 0.075 μ L Reverse Primer (100mM)
- 1.5 μ L 10 x PCR buffer (500 mM KCl, 100 mM Tris-HCl pH 8.3)
- 0.8 μ L MgCl₂ (25mM)
- 0.375 μ L dNTPs (8mM)
- 0.08 μ L AmpliTaq Gold DNA Polymerase (Applied Biosystems)
- H₂O to make up to 15 μ L

Optimised Thermocycling conditions:

- 96°C for 14 minutes (initial denaturation)
- 96°C for 30 seconds (denaturation)
- 55°C for 30 seconds (annealing) x 35 cycles
- 72°C for 30 seconds (extension)
- 72°C 5 minutes final extension

2.1.5.2 DNA Genotyping

Genomic DNA from donors was genotyped for SNP in rs2476601, which was achieved by RFLP. Genomic DNA from each donor was isolated during DNA extraction described above and was used to genotype for single nucleotide polymorphism rs2476601. PCR was performed for each genomic DNA sample in a total reaction volume of 15 μ l as above. For the restriction digests 10 μ l of PCR product were digested for 3 hours at 37°C with XcmI restriction enzyme with 10x NEB2 enzyme buffer and H₂O. Digested products were then electrophoresed, 10 μ L/well (3 μ L of loading dye was added to each 15 μ L PCR reaction) through a 2% agarose gel. The gel was then scored following UV visualisation. The enzyme cuts at the T allele, when visualised uncut bands were of 184 base pairs in length and cut bands were 141bp/43bp long.

2.2. Cell culture

All cells were cultured at 37°C in a 5% CO₂ humidified incubator. All cell culture reagents were purchased from Invitrogen.

Primary human/mouse T cell culture medium	Iscove's Modified Dulbecco's Media (IMDM) containing: 10% v/v heat inactive FCS 1X Pen/Strep 20mM HEPES (for mouse culture 50uM 2-ME was added)
Cell line culture	Roswell Park Memorial Institute medium (RPMI) containing: 10% v/v FCS 1X Pen/Strep

2.2.1 PBMC isolation and T cell culturing

Blood was drawn from donors or washed from a cone (NHS blood services) and diluted 1:2 with HBSS. Blood was then layered onto lymphoprep before being spun at 560g for twenty minutes brake off. An interface of PBMCs was then carefully removed and washed 2X in PBS. Cells were then resuspended in complete medium containing 1µg/mL phytohaemagglutinin (Thermofisher) for 48-72 hours before being washed and resuspended in 20ng/mL IL-2 (Proleukin, Novartis) after which cells were cultured

for a further 10 days. T cells were used for functional and biochemical studies between days 10 and 14 of culture.

2.2.2 Isolation of human T cells by negative selection

T cells were negatively selected using MACS columns supplied by Miltenyi according to manufacturers protocol. Subsequently, T cells were stimulated with anti-CD3 clone OKT3 from BDBioscience to investigate Lyp expression in untouched versus stimulated primary human T cells.

2.2.3 Isolation and culture of murine T cells from lymphoid organs

Excised spleens and lymph nodes were passed through a 70µm nylon strainer using a sterile syringe plunger. The strained cells were then centrifuged at 270g for 10 mins, washed 2X in serum free IMDM and then resuspended at 5×10^6 cells/mL in 1µg/mL Concanavalin A (ThermoFisher). After 3 days, cells were washed in full medium and resuspended in 20ng/mL IL-2 (Proleukin, Novartis) and cultured for a further two days before being used for functional and biochemical experiments (day 7-11).

2.2.4 Transfection of cell lines

For transfections $1-2 \times 10^7$ cells were used per transfection.

1. Wash cells in PBS for 1300 at RT for 5 mins.
2. Resuspend in Optimem (37°C)
3. Add vector DNA
4. Make sure machine is set at exponential decay V=270 capacitance=950
5. Transfer cells to cuvette.
6. Pulse.

7. Resuspend cells in RPMI (using pipette to ensure you don't take up dead cells).

Transfection of primary T blast cells using nucleofection (AMAXA)

1. Wash 1×10^7 T cells in PBS (following 2 days of stimulation)
2. Resuspend in 100 μ L transfection buffer with DNA.
3. Set programme (optimised for 2 programmes: T-023 (better viability but less efficient transfection) and T020 (less viability but more efficient transfection))
4. Transfer cell into cuvette, pulse, stand on ice for 2 mins and then carefully drop transfected cells into pre-equilibrated (24h in incubator) medium containing no IL-2
5. Check transfection efficiencies/knockdowns by blot or FACS 24 and 48 hours later

2.3. Biochemistry

2.3.1 Western Blotting

Cell lysates were prepared by either directly lysing samples in 95°C reducing sample buffer or by using a specific lysis buffer that could subsequently be used in biochemical assays such as immunoprecipitation or co-immunoprecipitation.

2.3.2 Preparing cell lysates in sample buffer

Cells were washed once in ice cold HBSS containing 20mM Hepes and the lysed directly in boiling sample buffer (for most applications around 1 cell/1µL of sample buffer).

Sample buffer was prepared as follows:

2X sample buffer

0.5 M Tris-HCl, pH 6.8 2.5 ml

Glycerol 2 ml

10% (w/v) SDS 4 ml

0.1% (w/v) Bromophenol Blue 0.5 ml

1M DTT 1 ml

2.3.3 Preparing cell lysates in cell lysis buffers

The following cell lysis buffers were used.

Standard lysis buffer recipe:

20mM Tris-HCl pH6.8

130-150mM NaCl

5mM EDTA

0.1-1% Triton

1X Complete protease inhibitor cocktail (1 tablet/7mL lysis buffer)

1X Complete phosphatase inhibitor cocktail (1 tablet/7mL lysis buffer)

For raft dissociation lauryl maltoside or n-octyl-beta-glucopyranoside was added at between 40-60mM. In some instances 1% Triton was replaced with 0.5%-1% lauryl maltoside.

Cells were lysed in ice cold lysis buffer following an experimental procedure (detailed below or above) and were placed on ice for 20mins. The lysates were then cleared by microcentrifugation for 20 mins @ 30,000g. These lysates were then diluted in 2X sample buffer, heated at 75°C for 15 mins and used for whole cell lysate analysis.

Alternatively, the lysates were used for immunoprecipitation or co-immunoprecipitation experiments.

2.3.4 Immunoprecipitation and Co-immunoprecipitation

Cell lysates, prepared with lysis buffers that allow subsequent biochemical investigation by way of capturing and then concentrating specific proteins from a whole cell lysate using specific antibodies, were performed as follows.

1. Cell lysates were prepared using an appropriate lysis buffer that was kept at 4°C at all times (working in cold room as necessary; particularly important for co-immunoprecipitation experiments).
2. 1-2µg of specific or isotype antibody/normal serum was added to lysates that were at a concentration of 1µg/µL.
3. Incubate at 4°C overnight.
4. Add protein A or protein G magnetic beads to lysates (match Fc binding protein with species of antibody).
5. Incubate 1 hour at 4°C.
6. Wash 3-6X in ice cold PBS or lysis buffer (0.1-1% Triton) stocked with protease and phosphatase inhibitors.
7. Transfer to new 1.5mL eppendorf, elute with 20-30µL of sample buffer.
8. Proceed to Western Blot.

2.3.5 Signalling Experiments

To investigate the biochemical consequence of integrin ligation a protocol that most closely resembles that of an *in vivo* situation was developed. That is, the migration of T cells on a 2D surface (endothelium), albeit without flow. This protocol facilitated the migration of cells on a surface coated with an integrin ligand, rather than relying on receptor cross-linking experiments using antibodies that can lead to abnormalities in the amplitude and the duration of the signal. In this system, cells polarise and visually resemble a cell migrating *in vivo*, exhibiting a clear leading and lagging edge. In addition, this protocol permitted the imaging of cells at high resolution and complementary experiments designed to define the localisation and co-localisation of signalling intermediates (see imaging section).

3.5.1 Plate bound integrin signalling assay

- 1) A 32mm round borosilicate glass coverslip was placed into a 6 well dish.
- 2) 250µL of ICAM-Fc (4µg/mL) VCAM-Fc (4µg/mL) or Fibronectin (10µg/mL) was carefully pipetted on top of the coverslip and another coverslip was then placed on top to create a coverslip “sandwich”. As a control, coverslips were sandwiched with 0.01% poly-L-lysine.
- 3) After incubating overnight at 4°C the coverslip sandwich was disassembled and the top coverslip was placed in the well below. These coverslips were then blocked with 5% BSA.
- 4) Coverslips were then washed 3X in HBSS HEPES.

- 5) 2×10^7 cells in 1mL were then pipetted carefully onto the coverslips and placed into the incubator for indicated times.
- 6) After removing excess unbound cells, bound cells were then lysed on the plate and transferred into eppendorfs after incubation on ice for 20 mins, cleared and used for total lysate analysis or immunoprecipitation studies as described above

2.3.6 SDS-PAGE, protein transfer and probing with antibodies

Sodium dodecyl sulphate polyacrylamide gel electrophoresis (SDS-PAGE) allows the separation of proteins by their weight and mobility. SDS coats and denatures proteins such that they are evenly charged and unfolded, which in most cases allows for separation based on protein weight alone. In some instances however, particularly when proteins contain post translational modifications, largescale shifts in mobility that do not necessarily correspond to changes in molecular weight can be observed.

Lysates were combined with 2X reducing sample buffer and heated to 75°C to denature proteins. Proteins were resolved on 4-12% polyacrylamide gels at 120V for 2 hours in MES running buffer. 5µl of Precision Plus protein ladder was run alongside samples to establish the molecular weights of the bands detected.

SDS-PAGE separated proteins were then transferred to polyvinylidene fluoride (PVDF) membranes that were soaked in methanol and then preequilibrated in transfer buffer before the transfer was carried out by electroblotting at 30V.

Following transfer of proteins onto PVDF, the membranes were blocked with 5% BSA TBST for one hour and then incubated overnight at 4°C with primary antibody. The membrane was then washed 2X in TBST and then incubated with secondary antibody

conjugated to horseradish peroxidase which targeted the primary antibody for 30 minutes. Membranes were then washed 3X for 15 minutes in TBST and proteins of interest were visualised with enhanced chemiluminescence (ECL) solution (GE Healthcare, UK). Bands of interest were detected in a BioRad ChemiDoc, allowing instant visualisation via chemiluminescence.

2.4. IMAGING

2.4.1 Cell fixation using pH shift method

The pH shift/formaldehyde method was first used for fixing rat brain, in which it showed excellent preservation of neuronal cells and intracellular compartments (Berod et al., 1981). This technique applies the formaldehyde to the tissue twice: once at near physiological pH to halt metabolism, and then again at high pH, where the crosslinking action of the fixative is more effective.

1) Wash cells and resuspend into 1×10^6 /ml HBSS/HEPES

2) Add 300 μ l of cells on precoated coverslips (acid wash as necessary) in 24well plate and incubate cells for desired time.

3) Fix cells in 3% paraformaldehyde (PFA) in 80mM kPIPES (Sigma) pH 6.8 5 mM EGTA 2mM MgCl₂ for 5 min

4) Washed with PBS X1

5) Fix with 3% PFA in 100mM NaB₄O₂ (BORAX) pH11 for 10 min

6)Wash with PBS X1

7)Permeabilise with 0.1 % TritonX100 in PBS for 5 min 4C

8)Wash PBS X1

9)Block autofluoresence with 1 mg/ml of NaBH₄ for 15 min at room temperature.

10)Wash with PBS

11)Block with 10 % horse serum for 30-60 min. Adjust serum depending on secondary used...always try and use serum derived from the species in which your secondary was raised in.

12)Wash with PBS X1

13)Incubate in primary ab in 0.1%BSA in PBS overnight/ or 30-60 min room temperature depending on Ab.

14)Wash with PBS

15)Secondary ab normally 20 min RT (in dark)

16)Up to 8 small volume washes as necessary

2.4.2 Timelapse microscopy

8 well glass chambers (Ibidi) were coated with 3µg/mL ICAM-1Fc overnight at 4C, washed 3X in PBS after which cells were directly plated into prewarmed glass wells.

Imaging was started 10 minutes after plating of cells. All imaging was performed in HBSS/HEPES at 37C, 5% CO₂ in a Nikon BioStation IM-Q for 20 mins. Cell tracking was

performed using Image J plugin Celltracker. All plots were generated using Ibbidi Chemotaxis tool.

2.4.3 Confocal microscopy

An appropriate size glass coverslip was coated overnight with 4ug/mL of ICAM-1 or 0.01% PLL in HBSS. The coverslips were then blocked with 5% BSA PBS for 1 hour at room temperature and then washed 3X in HBSS 20mM HEPES of which cells were plated onto coverslips and brought to 37°C for 30 mins and then fixed using pH-shift described above. All primary antibodies were incubated overnight at 4C and then washed 2X followed by incubation with an appropriate secondary antibody. Confocal imaging was performed using a Nikon A1R+ confocal microscope. For confocal microscopy a Nikon A1R inverted laser scanning microscope was used together with a X63 1.4NA oil-immersion objective. Laser illumination was at 402, 488, 531 and 650nm and emission was at 421, 519, 554 and 668nm respectively. Pixel dwell time was 1.2 ms and a line averaging of 4 was used.

2.4.4 STORM-TIRF imaging

Ibbidi 8 well chambers were coated overnight with 4ug/mL of ICAM-1 or 0.01% PLL in HBSS. The coverslips were then blocked with 5% BSA PBS for 1 hour at room temperature and then washed 3X in HBSS 20mM HEPES of which cells were plated onto coverslips and brought to 37C for 30 mins and then fixed using pH-shift described above. All primary antibodies were incubated overnight at 4C and then washed 2X

followed by incubation with an AF647 conjugated secondary antibody. Imaging was performed using a standard oxygen scavenging buffer. Images were acquired with a Nikon STORM system. Analysis was performed using Dr D Owens cluster algorithm or Ripleys K function(Williamson, Owen et al. 2011). dSTORM imaging was performed on a Nikon N-STORM microscope using a 100X 1.46N.A. oil immersion TIRF objective. Cells were imaged under TIRF illumination with a 647 nm laser with photo-activation at 405 nm. Fluorescence was collected on an Andor iXon EM-CCD camera. Acquisition time was between 5 and 15 minutes and an integration time of 10 ms was used. Molecular coordinates were calculated by Nikon NIS N-STORM software using an appropriate threshold (mouse anti-Lyp=3000, goat anti-Lyp=4000 and mouse anti-LFA-1=3000).

2.4.5 STORM oxygen scavenging buffer

The oxygen scavenging buffer was made up of four individual components that were mixed just prior to use. These components were: 1)base buffer,2) glucose oxidase,3) horseradish peroxidase and4)

- 1) Base buffer: 100mL of base buffer was made up and stored at 4°C. 10mL of 10X PBS was added to 82.5mL of DDH₂O. 2.5mL of HEPES (1M), 1.25mL glucose (2M) and 3.75mL room temperature glycerol was then added to the diluted PBS giving a final concentration of 1X PBS, 25mM HEPES, 25mM glucose and 5% glycerol solution. The base buffer was then adjusted to pH 8.00 and filter sterilised (0.22µm).

- 2) Glucose oxidase: A stock solution of 10mg/mL glucose oxidase in 50mM sodium acetate pH 5.1 was made up and frozen immediately in aliquots of 10 μ l which were thawed just prior to use.
- 3) Horseradish peroxidase: A stock solution of 10mg/ml of horseradish peroxidase was made up in 0.1M potassium phosphate buffer pH 6.0 and frozen immediately in 5 μ l aliquots which were thawed just prior to use.
- 4) Cysteamine: A fresh stock of 1M cysteamine was made up just prior to use. The fresh stock was then 0.22 μ m filtered.

Just prior to imaging 500 μ l base buffer, 2.5 μ l glucose oxidase, 1.25 μ l horseradish peroxidase and 37.5 μ l cysteamine were added together yielding a final concentration of 50 μ g/ml glucose oxidase, 25 μ g/ml horseradish peroxidase and 75mM cysteamine in base buffer. This imaging buffer was replaced every 30mins to avoid complications arising from pH changes.

2.5. Flow cytometry

2.5.1 Staining protocol:

- 1) Harvest cells
- 2) Put in eppendorf and quick spin
- 3) Wash cells 1X with FACS buffer (500 μ l)
- 4) Resuspend in 70 μ l FACS buffer
- 5) Wash 1X with FACS buffer
- 6) Surface stain with primary antibodies in FACS buffer
- 7) Fix in 3% PFA for 15 mins (4 $^{\circ}$ C) centrifuge
- 8) Wash 1X with FACS buffer
- 9) Wash 1X with saponin buffer (save unstained cells for acquiring)

- 10) Add antibody+saponin buffer to cells
- 11) Incubate for 30 mins at 4°C in dark
- 12) Wash 1X with saponin buffer
- 13) Was 1X with FACs buffer
- 14) Resuspend in 200µL FACS buffer

2.5.2 Lyp staining:

- 1) Wash cells in FACs buffer
- 2) Fix in 2% PFA for 15 mins
- 3) Wash with FACS buffer
- 4) Wash 1X with saponin
- 5) Make up Lyp polyclonal antibody 1:50 in Saponin buffer, add to cells and incubate for 30 mins on ice.
- 6) Wash X1 with saponin
- 7) Add secondary 1:100 in 200µl of saponin buffer for 10 mins, wash 1X in saponin buffer and then resuspend in 200µl FACS buffer

2.5.3 FACS sorting

Lyp-GFP fusion constructs were transfected by AMAXA into primary T blasts and then sorted on GFP. Live cells expressing Lyp-GFP were sorted using a FACSAria (see results).

2.6. Antibodies and Reagents

The following primary antibodies were used in this study: goat/mouse anti-Lyp (RnD), mouse anti-LFA-1/mAb38 (Calbiochem), rabbit anti-Csk, mouse anti-CD3 ξ , mouse anti-Lck, rabbit anti-ZAP-70, rabbit anti-Vav (Santa Cruz), rabbit anti-Lck, rabbit anti-pY418 Src, mouse anti-pY505 Lck, Rabbit anti-non-pY418 Src, rabbit anti-pYERK1/2, rabbit anti-ERK, rabbit anti- β -actin, rabbit anti- β -tubulin, rabbit anti-pY493ZAP-70, rabbit anti-pY319ZAP-70 (Cell Signalling Technology, through NEB UK), anti-ZAP-70, anti-CD11a-PE (BD bioscience), mouse anti-Csk, rabbit anti-pY174 Vav (Abcam). Examples of full blots for immunoprecipitations can be found in the appendix.

The following secondaries were used in this study: anti-mouse HRP (Amersham), anti-goat/rabbit HRP (DAKO), anti-light chain specific mouse/rabbit (Jackson laboratory), anti-mouse/rabbit goat alexa fluor conjugated antibodies (Invitrogen).

Chapter 3
***The Lyp-Csk-PAG complex regulates Lck
phosphorylation downstream of LFA-1
engagement***

3.1 Lyp is up regulated in activated T cells

T cells can express proteins at different levels depending on their activation and differentiation status and environmental pressures. Understanding the expression of Lyp in resting/unstimulated versus activated T cells could provide important clues as to when, during the T cell life cycle, Lyp may function to regulate intracellular signalling pathways. The goal of these initial experiments was to examine the expression of Lyp in primary human T cells before and after stimulation, using two complementary experimental approaches – immunoblotting and flow cytometry.

T cells were purified by negative selection using magnetic bead separation (MACS pan T cell kit-II). Staining of untouched cells passing through the MACS column with anti-CD3 α antibodies and analysis by flow cytometry confirmed that over >96% of purified cells were of a CD3 lineage (Figure 3.1A). Purified T cells were then stimulated either through the T cell receptor with plate-bound anti-CD3 together with anti-CD28 co-stimulation, or activated by cross-linking lectin family receptors with a phytohaemagglutinin that binds to and clusters glycosylated sugar moieties on the extracellular domain of transmembrane proteins. Cultures of activated T cells were propagated by the addition of IL-2 for up to 10 days. Lyp expression was then determined after the indicated periods of time by western blotting and flow cytometry. A fraction of the CD3⁺ population was lysed immediately for western blot analysis using anti-Lyp antibodies and anti- β -actin antibodies as a loading control, or fixed and permeabilised, then stained with different dilutions of a goat anti-Lyp antibody and an anti-goat secondary antibody prior to FACS analysis. As a control, cells were stained with normal goat serum at equivalent dilutions to the primary antibody.

Representative results for immunoblotting of anti-CD3/CD28 stimulated T cells, and for flow cytometry of PHA stimulated T cells are shown in Figure 3.1B. Immunoblotting demonstrated up regulation of Lyp by 48hrs, when compared to β -actin, and Lyp expression remained stable over periods of time for up to 144hr, when compared to pre-stimulation levels (Figure 3.1B). Flow cytometric analysis of fixed and permeabilised T cells using serial dilutions of anti-Lyp antibody also confirmed up regulation of Lyp in PHA blasts cultured for up to 10 days (Figure 3.1C).

These results indicated that in activated T cells or "T blasts" Lyp is up regulated when compared to unstimulated T cells. Accordingly, activated T cells were used in all subsequent experiments.

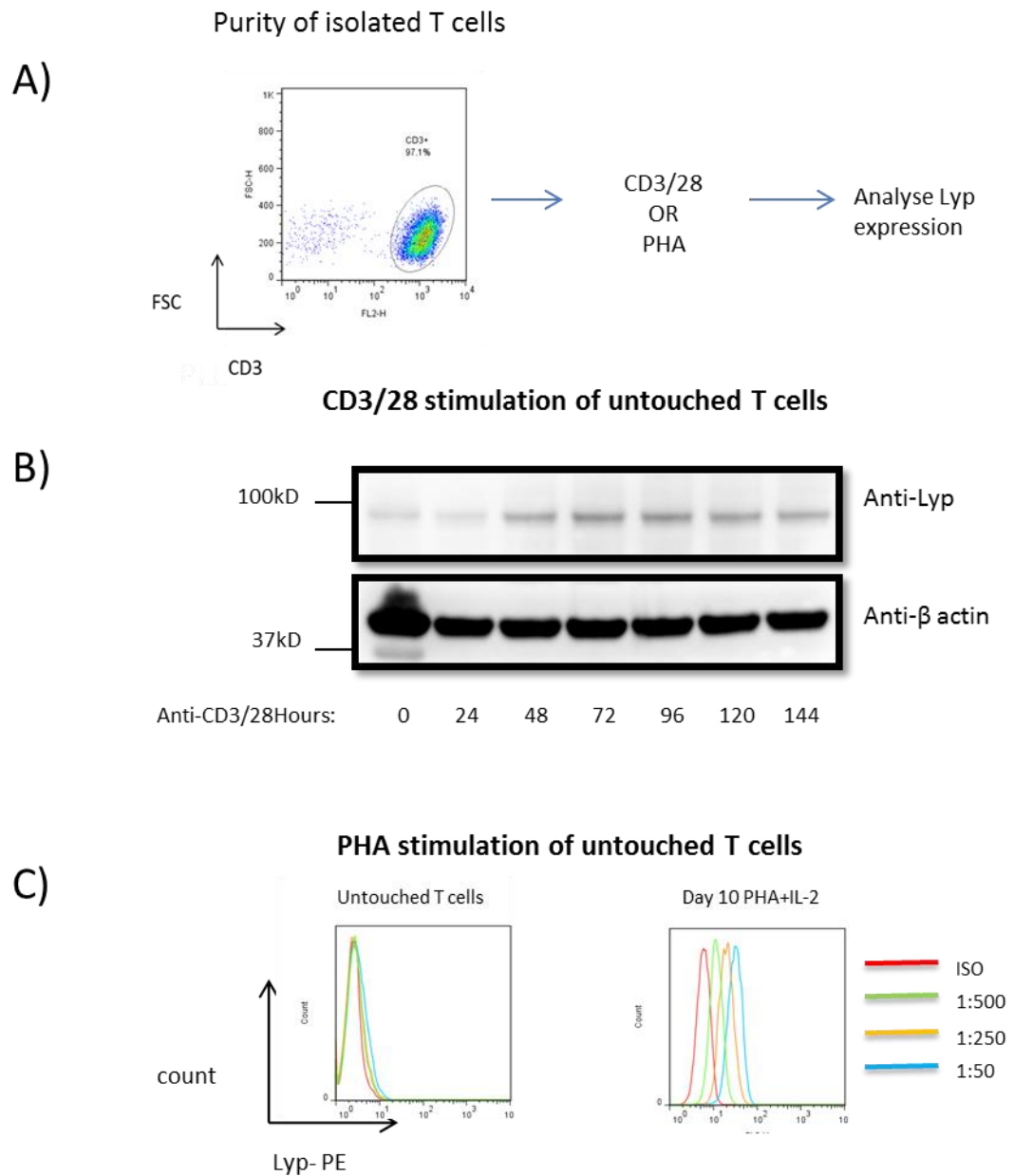

Figure 3.1: Lyp is up regulated in activated T cells A) Purity of negatively selected T cells was confirmed with an anti-CD3 stain followed by FACS analysis; B) Purified T cells were stimulated with anti-CD3/28 (bead to cell ratio of 1:10) for various time points and

Lyp expression was evaluated by Western blotting, anti- β actin antibody was used as a loading control;

C) Purified T cells were cultured in PHA (1 μ g/mL) for 48 hours and then in IL-2 (Proleukin 20ng/mL) until day 10 when Lyp expression was assayed by FACS.

Representative of at least 4 independent experiments

3.2 Lyp localises to the leading and lagging edge of migrating T cells.

When activated T cells migrate they undergo morphological changes as well as subcellular reorganisation of compartments to facilitate locomotion. As a first step towards evaluating the possibility that a signalling intermediate may function as a regulator of T cell migration it would be important to determine its subcellular location and its ability to associate with, or avoid, other signalling intermediates upon engagement of cell surface LFA-1 with its integrin ligand ICAM-1. To this end, the expression and subcellular localisation of Lyp in T cell blasts was investigated by confocal microscopy. Cells were stained with a goat polyclonal or mouse monoclonal anti-Lyp antibody following immobilisation of T cells on poly-L-lysine or ICAM-1.

In cells plated onto poly-L-lysine different patterns of staining were observed, with some cells displaying membrane proximal staining only, whilst others demonstrated both membrane proximal and cytoplasmic staining (Figure 3.2A). As expected, when T cells attach to immobilised ICAM-1, they become polarised, displaying a clear leading edge, in the form of a spread out structure at the front of the cell called a lamellopodium, and a "tail" at the back of the cell called the uropod. This asymmetric configuration of the cell leads to the assembly of specific cellular components within certain compartments in the cell, allowing for protrusive, contractive and adhesive force generation. Under these conditions, Lyp clearly localises to the front of the cells. Some staining was also consistently observed in the uropod (Figure 3.2B). The images shown in Figure 3.2 are confocal images acquired at the coverslip level, because when stacked, the staining in the uropod became less clear. In Figure 3.2C, a stacked image of confocal slices clearly demonstrates leading edge localisation, with quantitation

indicating that the lagging edge of the cell also stained positive for Lyp. Interestingly, very little Lyp could be detected within the mid-cell region. In some cells, the staining of Lyp appeared diffuse, suggesting that Lyp localisation may be dynamic and not always at the leading edge (see Figure 3.2C lower left panel). The staining patterns of Lyp were verified using two different antibodies derived from different host species (Figure 3.2D). Specificity of staining was verified using a non-specific isotype control antibody, which demonstrated no specific staining using exactly the same microscope acquisition settings as those used to acquire images with the specific Lyp antibody (data not shown).

Together these results provided the very first indication that Lyp may regulate pathways involved in T cell migration based on the fact that Lyp polarises to the leading and lagging edge of migrating T cells, and that this localisation may be dynamic in nature. This pattern of compartmentalisation might indicate that Lyp operates at the front and the back of a migrating T cell. Conversely, sequestration of Lyp from the mid cell zone, might serve to limit the interactions of Lyp with signalling intermediates in the mid cell region.

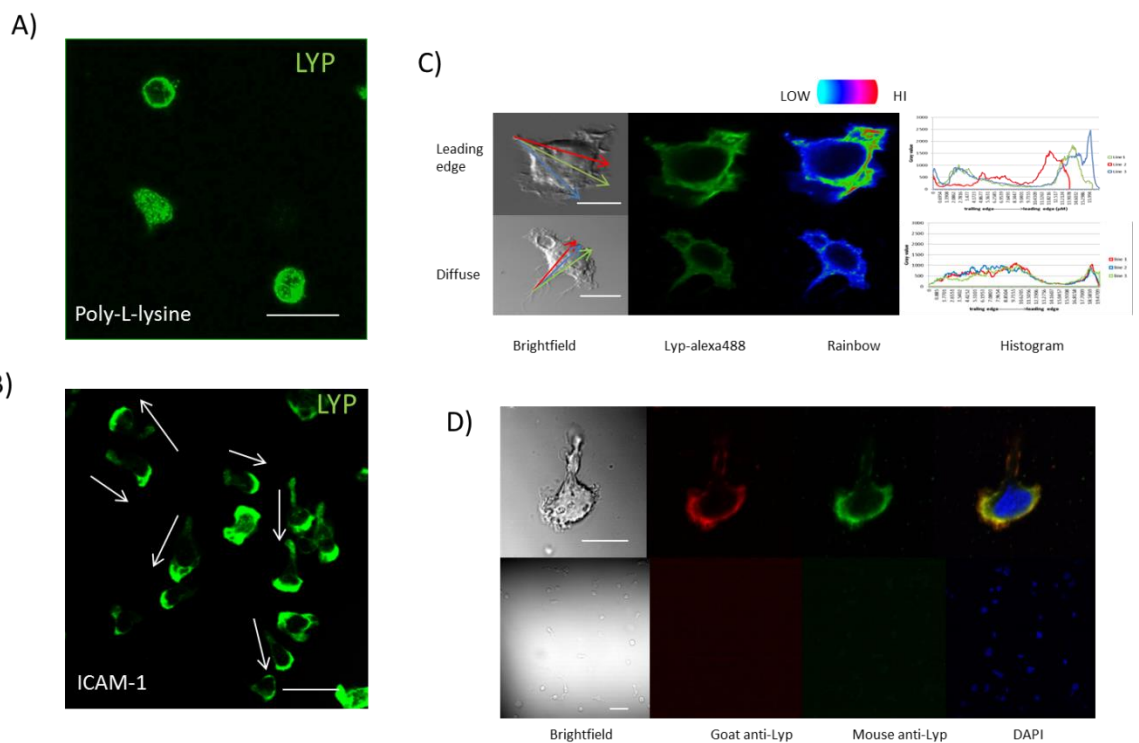

Figure 3.2 :Lyp localises to the leading edge of migrating T cells A+B) T cells that had been stimulated with PHA (1 μ g/mL) for 48 hours and then cultured in IL-2 (Proleukin-20ng/mL) for a further 8 days were immobilised on PLL (0.01%) (A) or were allowed to migrate on ICAM-1 (4 μ g/mL) (B) and were then pH-shift fixed and stained with an anti-Lyp antibody followed by an AF488 secondary. C) Histogram quantification of fluorescent intensity in leading versus lagging edge of migrating T cells on ICAM-1 and stained with anti-Lyp and an AF488 secondary (X axis=length scale of cell, with leading

and lagging edge denoted and Y axis=fluorescent intensity units D) Migrating T blasts were co-stained with goat and mouse anti-Lyp and then incubated with mouse secondary AF488 and goat secondary AF647. All data representative of at least 5 independent experiments. Scale bar=10 μ m All images were acquired using scanning confocal microscope

3.3 Lyp, Csk and PAG colocalise at the leading and lagging edge of migrating T cells

Lyp is localised at the membrane of T cells and one possible explanation for this localisation may be the interaction with other signalling intermediates that serve to target Lyp to the membrane. Csk is a binding partner of Lyp, and Csk has been shown to localise to the plasma membrane by interacting with a highly phosphorylatable transmembrane scaffolding protein, Protein Associated with GEMS (PAG). Phosphorylated PAG retains Csk at the membrane through the interactions of an SH2 domain of Csk and a phosphorylated tyrosine residue (pY317) on PAG. This PAG-Csk interaction is thought to provide tonic inhibitory activity on Src family kinases by phosphorylating an inhibitory tyrosine residue in the C-terminus of Src family kinase members such as Lck and Fyn. Interestingly, it has been reported in T cells that Fyn is responsible for phosphorylating PAG and is able to avoid inactivation by Csk when docked onto PAG. According to this model, when receptor signalling is initiated, Fyn dissociates from PAG, PAG is then dephosphorylated, possibly by CD45, releasing Csk, allowing for local membrane proximal raft associated activation of Src, which in T cells might include Lck and Fyn. One hypothesis is that Lyp may localise to the membrane via the PAG-Csk complex.

To test this hypothesis, activated primary human T cells were stained with specific antibodies directed at Lyp, Csk and PAG after immobilisation on poly-L-lysine or ICAM-1 (Figure 3.3). Confocal images of cells immobilised on poly-L-lysine suggested Lyp/Csk/PAG colocalisation at the membrane. In migrating T cells, Lyp and Csk polarised to the front and back of the cell, whilst the staining pattern of PAG was more diffuse with expression at both leading and lagging edge, where it co-localises with Csk

and Lyp. To control for these experiments, a series of experiments were undertaken where species specific secondary antibodies were used in combination with co-stains of the two antibodies that could not be targeted. For example, goat anti-Lyp and rabbit anti-Csk stains were probed with anti-mouse antibodies to check for species cross reactivity, or mouse anti-PAG and rabbit anti-Csk stained slides were probed with anti-goat antibodies (Figure 3B). In this way I had more confidence that the staining patterns observed were unlikely to be due to cross reactivity between the secondary antibodies. In addition, single stains were performed to verify staining patterns, with secondary antibodies alone as a control (data not shown).

These experiments indicated that Lyp, Csk and PAG appear to colocalise in non-migrating and migrating cells, with colocalisation being much more localised to the leading and lagging edge in migrating cells. Interestingly, in T cells immobilised on poly-L-lysine the level of colocalisation between Csk, Lyp and PAG appeared to be higher. While these data suggest that Lyp, Csk and PAG are in close proximity to one another, as expected, further biochemical evidence would be required to confirm whether these signalling intermediates are physically interacting, and the context in which these interactions were occurring.

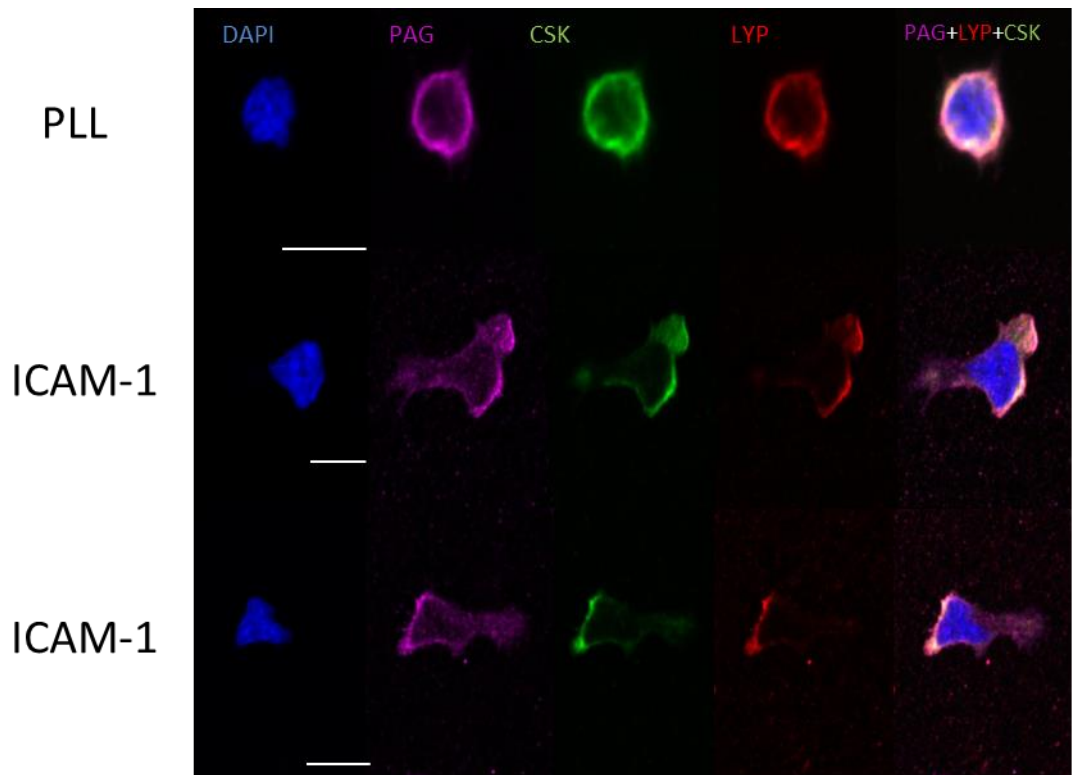

Figure 3.3: Lyp localises to the leading edge in migrating T cells. T cells that had been stimulated with PHA (1 μ g/mL) for 48 hours and then cultured in IL-2 (Proleukin-20ng/mL) for a further 8-10 days were immobilised on PLL (0.01%) or were allowed to migrate on ICAM-1 (4 μ g/mL) for 30 mins, were pH-Shift fixed, stained with mouse anti-PAG, rabbit anti-Csk and goat anti-Lyp, as indicated in top right hand corner of each panel, and then stained with anti-mouse AF647, anti-rabbit AF488 and anti-goat 546 prior to imaging by scanning confocal microscopy. Representative of 3 independent experiments Scale bar=10 μ m

3.4 Dynamics of the Lyp-Csk-PAG complex in T blasts migrating on ICAM-1

To test how the interaction of Lyp, Csk and PAG might change during integrin signalling, co-immunoprecipitation experiments were performed on migrating cells or cells immobilised on poly-L-lysine.

3.4.1 Lyp associates with Csk when T cells migrate on ICAM-1

The Lyp-Csk interaction is well documented and this interaction is at least partially dependent on the interaction of the first polyproline motif (PLPXR) in the C terminus of Lyp and an SH3 domain on Csk. The functional reason for this interaction remains obscure, and the interaction of Lyp with Csk during a signalling event is controversial. Some signalling studies suggest an inducible association of these two signalling intermediates following receptor ligation, or indeed dissociation, following receptor ligation, despite a common signalling pathway being investigated (the TCR). Here I investigated the relative stoichiometric changes in the Lyp-Csk complex when T cells migrate on ICAM-1.

Co-immunoprecipitation experiments demonstrated that Lyp and Csk clearly complex when T cells migrate (Figure 3.4A, B and C), as indicated by increased levels of Csk in Lyp immunoprecipitates from migrating versus non-migrating cells using different Lyp antibodies raised in different animal species (goat and mouse). It was notable that there was a basal level of interaction between Lyp and Csk in blasting T cells, and that the level of association between Lyp and Csk increased by approximately two-fold as demonstrated by two different antibodies (Figure 3.4C).

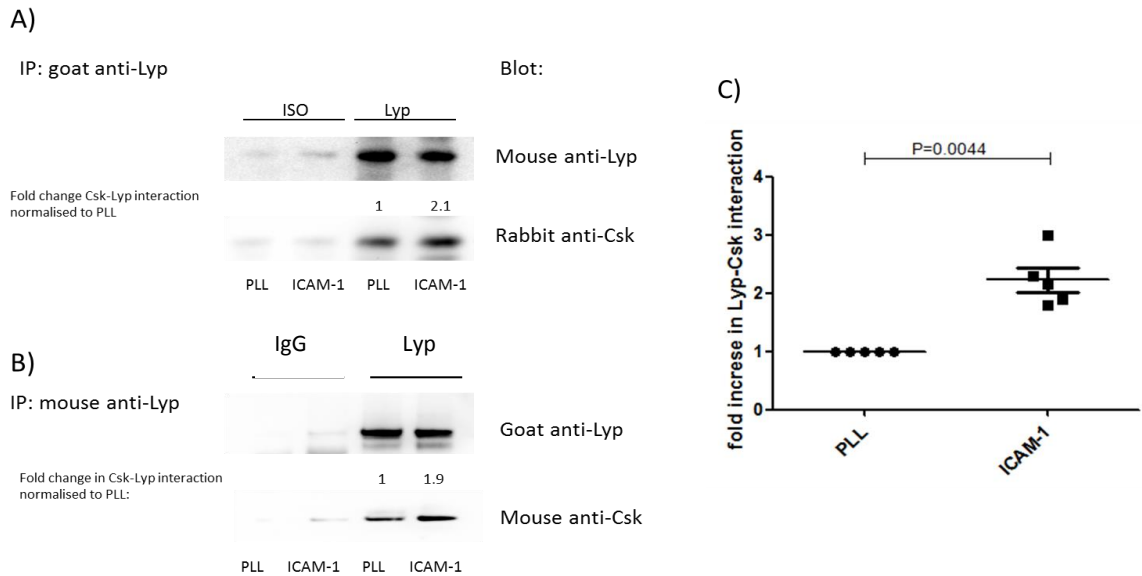

Figure 3.4: Lyp and Csk associate in migrating T blasts A) T cells that had been stimulated with PHA (1 μ g/mL) for 48 hours and then cultured in IL-2 (Proleukin-20ng/mL) for a further 8-10 days were immobilised on PLL (0.01%) or were allowed to migrate on ICAM-1 (4 μ g/mL) for 30 mins in 6 well dishes. After 30 mins, excess cells were aspirated and 1mL lysis buffer containing 1% Triton X-100 was added to well 1 where cells were lysed and then the lysis buffer was transferred to well 2 until all cells attached to the 6 wells in the dish had been lysed in a total of 1mL lysis buffer. The lysates from ICAM-1 and PLL were split (500 μ L/Eppendorf) and either a non-specific goat IgG or a goat anti-Lyp was used for the immunoprecipitation overnight at 4C. The following day Protein G magnetic beads were added to each Eppendorf for 30 mins at 4C. The beads were then washed 3X in standard lysis buffer containing 1% Triton and the antibody was eluted from beads with 20uL of boiling sample buffer. The eluates

were resolved by SDS-PAGE and transferred to PVDF where they were probed rabbit anti-Csk or mouse anti-Lyp. (B) Co-immunoprecipitation performed on T cells as in Figure 3.4A but using an anti-Lyp mouse monoclonal antibody, probed with mouse anti-Csk and goat anti-Lyp ; C) Densitometric quantification of blots shown in Figure 3.4A and B, representative of 5 independent experiment (4 mouse anti-Lyp and 1 goat anti-Lyp).

To confirm these data, immunoprecipitations of Csk were performed prior to blotting with anti-Lyp antibodies. These experiments confirmed that Lyp and Csk do indeed complex in migrating cells, and in good agreement with the Lyp co-immunoprecipitation experiments, there was a two fold increase in Csk-Lyp interaction (Figure 3.5).

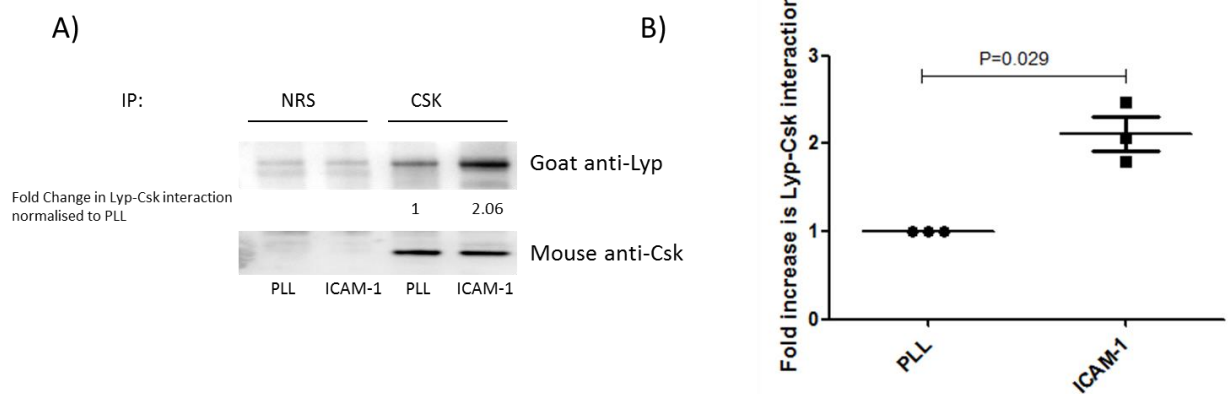

Figure 3.5 Lyp and Csk associate in migrating T cells: A) T cells that had been stimulated with PHA (1µg/mL) for 48 hours and then cultured in IL-2 (Proleukin-20ng/mL) for a further 8-10 days were immobilised on PLL (0.01%) or were allowed to migrate on ICAM-1 (4µg/mL) for 30 mins in 6 well dishes. After 30 mins, excess cells were aspirated and 1mL lysis buffer containing 1% Triton X-100 was added to well 1 where cells were lysed and then the lysis buffer was transferred to well 2 until all cells attached to the 6 wells in the dish had been lysed in a total of 1mL lysis buffer. The lysates from ICAM-1 and PLL were split (500µL/Eppendorf) and either a non-specific antibody (normal rabbit serum) or an rabbit anti-csk was added to the lysates and

incubated overnight at 4C after which Protein G coated magnetic beads were added for 30 mins. The beads were then washed 3X in standard lysis buffer containing 1% Triton-x100, and the antibody was eluted from the beads with boiling sample buffer, resolved by SDS-PAGE, transferred to PVDF and probed with goat anti-Lyp and then mouse anti-Csk. B) Densitometric quantification of blots shown in Figure 3.5A, representative of 3 independent experiments.

3.4.2 The interaction between Lyp and Csk is completely abolished in rested T cells

The assays performed so far were all undertaken using T cells starved of IL-2 and serum for 1 hour. To test whether Lyp and Csk truly are constitutively associated, cells were rested for 12 hours in 2% BSA in the absence of IL-2. Interestingly, Lyp and Csk completely uncoupled under these conditions, as indicated by the PLL not displaying any pulldown over the control lanes of IgG2b or NRS in the case of Lyp and Csk, respectively, suggesting that whilst there may be some basal association of Lyp and Csk in T cells, the default setting of these two signalling intermediates in cells that are metabolically quiescent is uncoupled, and that in fact a signal is required to allow these two signalling intermediates to interact (figure 3.6A, B). This data supports the hypothesis that Lyp and Csk interact when T cells migrate on ICAM-1.

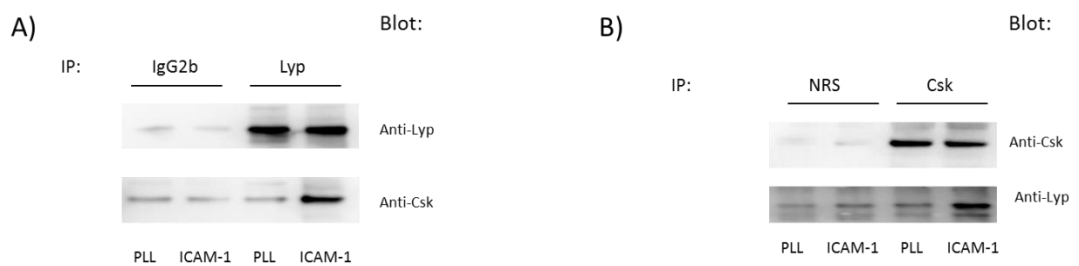

Figure 3.6: Resting T blasts leads to Lyp-Csk dissociating A) T cells that had been stimulated with PHA (1 μ g/mL) for 48 hours and then cultured in IL-2 (Proleukin-20ng/mL) for a further 8-10 days were immobilised on PLL (0.01%) or were allowed to migrate on ICAM-1 (4 μ g/mL) for 30 mins in 6 well dish. After 30 mins, excess cells were aspirated and 1mL lysis buffer containing 1% Triton X-100 was added to well 1 where cells were lysed and then the lysis buffer was transferred to well 2 until all cells attached to the 6 wells in the dish had been lysed in a total of 1mL lysis buffer. The lysates from ICAM-1 and PLL were split (500 μ L/Eppendorf) and either a non-specific

goat IgG or a goat anti-Lyp was used for the immunoprecipitation overnight at 4C. The following day Protein G magnetic beads were added to each Eppendorf for 30 mins at 4C. The beads were then washed 3X in standard lysis buffer containing 1% Triton and the antibody was eluted from beads with 20uL of boiling sample buffer. The eluates were resolved by SDS-PAGE and transferred to PVDF where they were probed rabbit anti-Csk or mouse anti-Lyp as indicated. B) The experiment was repeated as in (A) but rabbit anti-Csk was immunoprecipitated and probed with mouse anti-Csk and goat anti-Lyp. Representative of 2 independent experiments.

3.4.3 *PAG and Csk dissociate when T cells migrate on ICAM-1*

Lyp and Csk complex when T cells migrate on ICAM-1. To understand the context of this interaction, the dynamics of the Csk-PAG complex was further investigated. PAG is a scaffolding protein that partitions into highly ordered lipid domains within the plasma membrane, otherwise known as “lipid rafts”. This partitioning is thought to target the Csk bound PAG complex to rafts where tonic, negative regulation of Src family kinases is thought to take place (Torgersen, Vang et al. 2001, Davidson, Bakinowski et al. 2003). The catalytic activity of Csk is at least partially dependent on PAG binding, and so dissociation of PAG and Csk leads to inhibition of tonic inhibitory signals and therefore activation of Src (Wong, Lieser et al. 2005). The relationship between PAG and Csk has not yet been studied in migrating T cells, and given that Csk is an important binding partner of Lyp, it was important to investigate whether or not Csk was participating in integrin signalling.

To investigate the association of Csk with PAG in non-migrating versus migrating cells, Csk was immunoprecipitated, immunoprecipitates resolved by SDS-PAGE and blots probed with specific antibodies to PAG. Due to the highly ordered microdomains that PAG resides in, different detergents were tested to render PAG more accessible to immunoprecipitation. To this end cell lysates were prepared at 4°C from cell suspensions using either Triton X100 alone or Triton X100 plus N-octyl-beta-glucopyranoside (NOBGP) (Figure 3.7A). Blotting of cell lysates prepared using Triton X100 and NOBGP permitted detection of at least twice as much PAG, as compared to blots of lysates generated using Triton alone, suggesting that specific detergents that

can access microdomains are required to release PAG. Modest increases in Csk (~20%) and Lyp (~30%) were also detected in whole cells lysates using NOBGP, although this difference was less striking than the differences observed for PAG (Figure 3.7A).

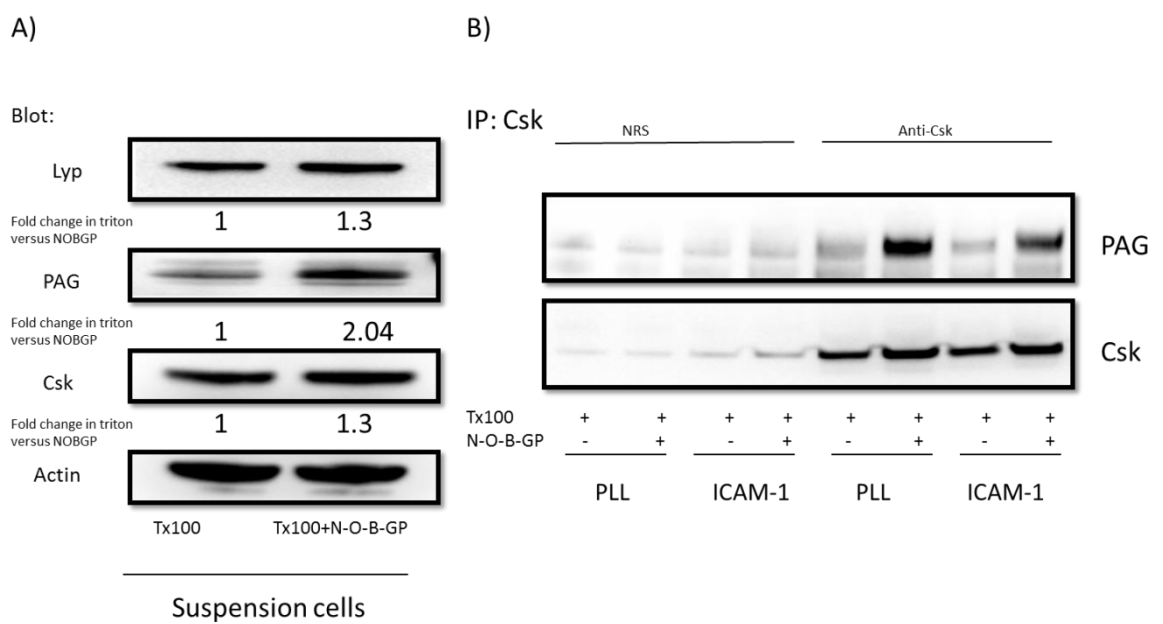

Figure 3.7: Detergent optimisation for PAG detection A) T blast cell lysates were made using either 1% Triton x100 or 1% Triton x 100+ 40mM NOBGP, prior to immunoblotting for Lyp, Csk and PAG; B) Csk was immunoprecipitated from lysates using different combinations of detergents prior to immunoblotting for PAG and then Csk. Representative of 2 independent experiments for (A) and for (B)

Using the same two detergent conditions for cell lysis, immunoprecipitations of Csk were then carried out to compare the association of Csk with PAG in non-migrating versus migrating cells. In Triton x100 lysates, detectable but low levels of PAG were associated with Csk in immobilised cells. In contrast however, a much stronger signal could be detected when NOBGP was included in the lysis buffer prior to immunoprecipitation, suggesting that PAG and Csk are indeed constitutively associated in non-migrating cells, and that this association occurred mainly within triton impenetrable microdomains (Figure 3.7B). In migrating cells less PAG was found to be associated with Csk. It was clear that PAG and Csk partially dissociated, as compared to immobilised cells, where a stronger PAG-Csk association was evident. Quantification by densitometry indicated that there was a 30% decrease in Csk-PAG association when T cells migrated on ICAM-1 (Figure 3.8 A and B). In addition, blots were re-probed with anti-Lyp and, consistent with previous results, increased Lyp-Csk association was observed in migrating cells (Fig 3.8C).

Together, these data suggest that Csk and PAG undergo a change in stoichiometry when T cells migrate, favouring dissociation of this complex. The dissociation of Csk from PAG is associated with an increase in detection of Lyp-Csk complexes.

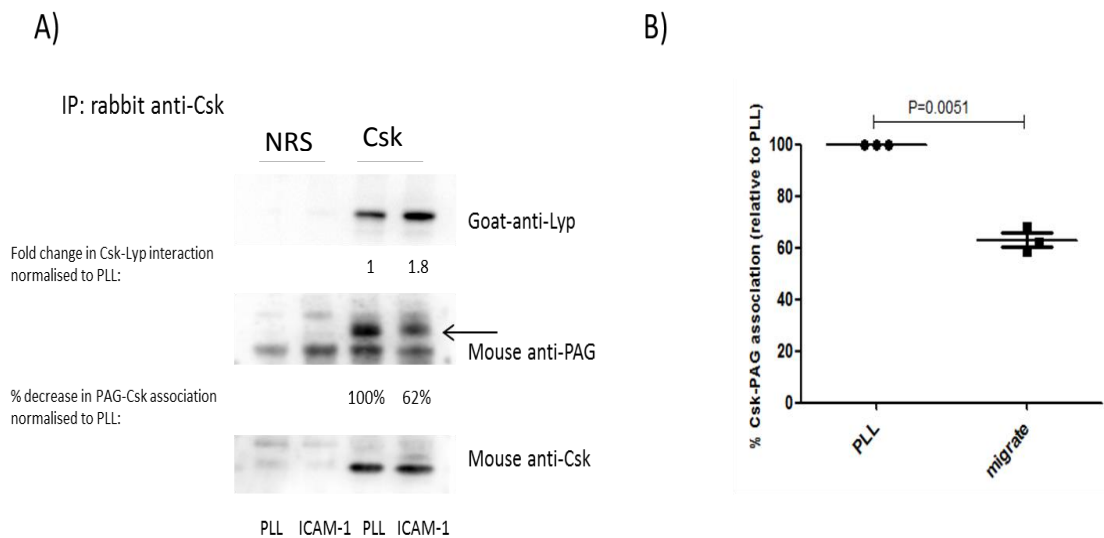

Figure 3.8: Csk associates with Lyp but dissociates from PAG when T blasts migrate on ICAM-1 A) T cells that had been stimulated with PHA (1 μ g/mL) for 48 hours and then cultured in IL-2 (Proleukin-20ng/mL) for a further 8-10 days were immobilised on PLL (0.01%) or were allowed to migrate on ICAM-1 (4 μ g/mL) for 30 mins in 6 well dishes. After 30 mins, excess cells were aspirated and 1mL lysis buffer containing 1% Triton X-100 40mM NOBGP was added to well 1 where cells were lysed and then the lysis buffer was transferred to well 2 until all cells attached to the 6 wells in the dish had been lysed in a total of 1mL lysis buffer. The lysates from ICAM-1 and PLL were split (500 μ L/Eppendorf) and either a non-specific NRS or a rabbit anti-Csk was used for the immunoprecipitation overnight at 4C. The following day Protein G magnetic beads

were added to each Eppendorf for 30 mins at 4C. The beads were then washed 3X in standard lysis buffer containing 1% Triton and the antibody was eluted from beads with 20uL of boiling sample buffer. The eluates were resolved by SDS-PAGE and transferred to PVDF where they were probed mouse anti-Csk, goat anti-Lyp or mouse anti-PAG as indicated. B) Densitometric analysis of PAG-Csk dissociation. Representative of 3 independent experiments.

3.4.4 PAG is dephosphorylated when T cells migrate on ICAM-1

PAG and Csk dissociate when T cells migrate, but the mechanism behind the dissociation in migrating cells was not known. Previous studies have demonstrated that Csk-PAG association is dependent on phosphorylation of a tyrosine residue at position Y317 on PAG that binds to an SH2 domain in Csk, and that this association is important not only for the positioning of Csk within raft platforms that act as signalling hubs, but also serves to potentiate the catalytic activity of Csk (Davidson, Bakinowski et al. 2003). The phosphorylation status of PAG might therefore govern raft associated Src activation by controlling the positioning and catalytic activity of Csk. The phosphorylation status of PAG was therefore investigated.

PAG was immunoprecipitated and an antibody recognising phosphotyrosine (pY) motifs was employed to evaluate the phosphorylation status of PAG, since no specific antibodies that recognise pY317 on PAG are available. A 30% decrease in PAG phosphorylation was observed in migrating cells (Figure 3.9), in good agreement with the Csk-PAG data which had indicated that around 30% of Csk dissociated from PAG after integrin stimulation (Figure 3.8). These data indicate that PAG is dephosphorylated in migrating T cells, and this in turn may lead to Csk relocating from rafts to another cellular compartment whilst concomitantly decreasing catalytic potential by the disengagement of the SH2 domain. However, a read-out of Csk catalysis was required in order to corroborate the data, and to this end we investigated the phosphorylation of a Csk target on Lck located in the C-terminal of the protein, namely tyrosine 505.

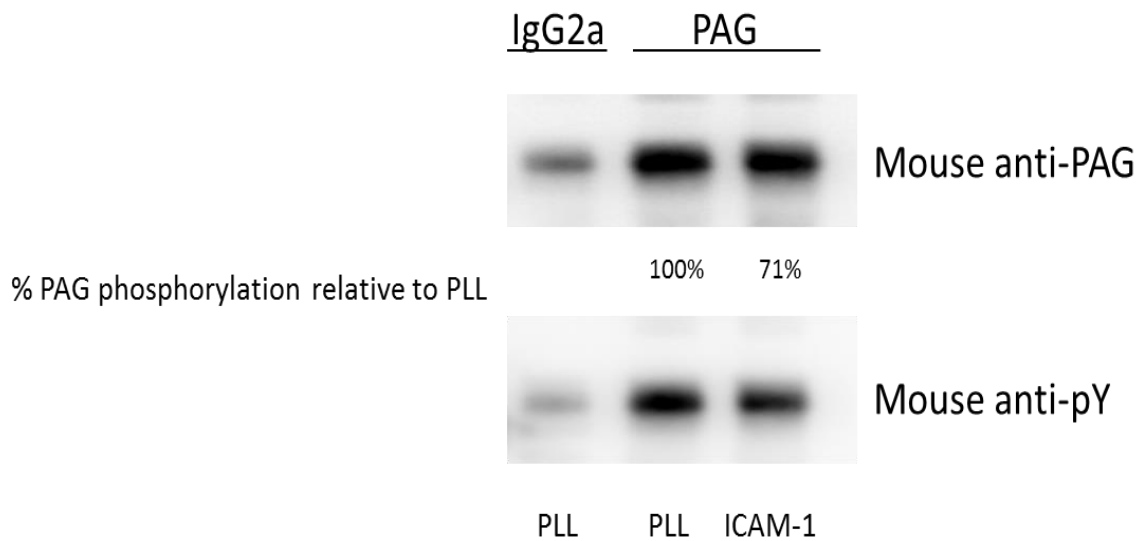

Figure 3.9: PAG is dephosphorylated in migrating T blasts A) T cells that had been stimulated with PHA (1µg/mL) for 48 hours and then cultured in IL-2 (Proleukin-20ng/mL) for a further 8-10 days were immobilised on PLL (0.01%) or were allowed to migrate on ICAM-1 (4µg/mL) for 30 mins in 6 well dishes. After 30 mins, excess cells were aspirated and 1mL lysis buffer containing 1% Triton X-100 40mM NOBGP was added to well 1 where cells were lysed and then the lysis buffer was transferred to well

2 until all cells attached to the 6 wells in the dish had been lysed in a total of 1mL lysis buffer. The lysates from ICAM-1 and PLL were split (500 μ L/Eppendorf) and either a non-specific isotype or mouse anti-PAG was used for the immunoprecipitation overnight at 4C. The following day Protein G magnetic beads were added to each Eppendorf for 30 mins at 4C. The beads were then washed 3X in standard lysis buffer containing 1% Triton and the antibody was eluted from beads with 20uL of boiling sample buffer. The eluates were resolved by SDS-PAGE and transferred to PVDF where they were probed mouse anti-pY or mouse anti-PAG as indicated. Representative of 2 independent experiments.

3.4.5 Csk tonically phosphorylates the inhibitory residue of Lck pY505 when T cells are immobilised on PLL and following LFA-1 engagement this inhibitory tyrosine residue is dephosphorylated.

The observation that Csk and PAG dissociate when T cells migrate on ICAM-1 might suggest a switch in the regulation of Src family kinases at the membrane, favouring conformations and catalytic potentials that can more readily initiate or maintain a signal. Given that Lck autophosphorylates, a switch favouring a conformation that increases binding activity might not only lead to Lck phosphorylating downstream targets, but also itself at the activatory residue in *trans*, especially in light of the molecule unfolding and being more readily phosphorylatable at the activatory loop within the kinase domain at residue Y394 (Ventimiglia and Alonso 2013).

To test this hypothesis, the phosphorylation status of Lck was investigated in the context of migration to document changes in phosphorylation that might promote changes in conformation and catalysis. Specifically, the phosphorylation status of Lck was investigated using as a read out the inhibitory pY505 site, a tyrosine residue that has been shown to be phosphorylated by Csk leading to downregulation of Lck activity. As a consequence of phosphorylation of Y505, the C-terminus folds inward and the pY505 residue interacts with an upstream SH2 motif, essentially occluding the catalytic domain in conjunction with a polyproline motif that is positioned by the SH2-pY505 interaction to interact with an SH3 domain. In addition, it was important to investigate the phosphorylation status of Lck at the activatory pY394 residue to monitor any net changes in activatory tyrosine residue phosphorylation that may occur at the same time. The availability of phospho-specific antibodies greatly facilitates this approach.

Figure 3.10 shows the analysis of both Triton soluble and Triton insoluble (Triton plus NOBGP) whole cell lysate fractions derived from non-migrating and migrating primary human T cells. In line with the previous finding of Csk dissociating from PAG in migrating cells (Figures 3.7 and 3.8), Lck was dephosphorylated at the inhibitory Y505 residue by 33% in the triton soluble fraction, and upon the addition of NOBGP a larger proportion of dephosphorylated Lck at Y505 could be detected, suggesting that detergent insoluble microdomains contain a larger proportion of dephosphorylated Y505 as compared to the Triton soluble domains (Figure 3.10A). As predicted, the dephosphorylation of pY505 was associated with an increase in pY394 in migrating cells. This was confirmed in experiments using an antibody that recognises unphosphorylated Y394; here there was approximately a 40% decrease in migrating cells, in keeping with the 2-fold increase in Lck pY394 (Figure 3.10B and C).

These data suggest that following LFA-1 engagement, Lck undergoes changes in phosphorylation that are known to favour catalytic activity and binding by allowing the molecule to interact with target substrates through conformational change and increased rates of catalysis. The dissociation of Csk from PAG and the changes in Lck phosphorylation might to be a general mechanism by which integrins signal, because when experiments were performed with other integrin ligands like fibronectin or VCAM, a similar change in pY505 phosphorylation was observed (Figure 3.11), although the PAG-Csk dissociation was not investigated in the context of these integrin ligands.

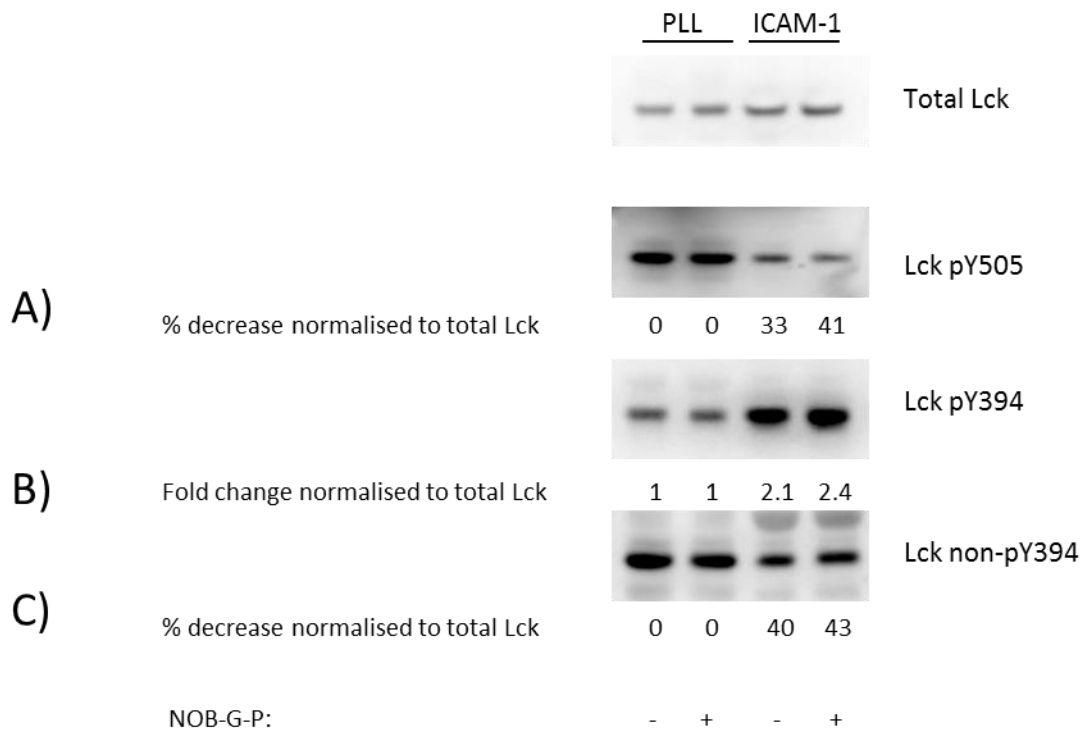

Figure 3.10: Lck undergoes changes in phosphorylation when T blasts migrate on ICAM-1. Total lysates were made from PHA stimulated T cells that had been cultured in IL-2 for 8-10 days. Cells were plated onto PLL (0.01%) or ICAM-1 (4µg/mL) and lysed using different detergent combinations (Titon X alone or Triton X+NOBGP for raft dissociation) to investigate the phosphorylation status by Western Blot of Lck using antibodies specific for(A) pY505, (B) pY394 and (C) non-pY394. Representative of 3 independent experiments.

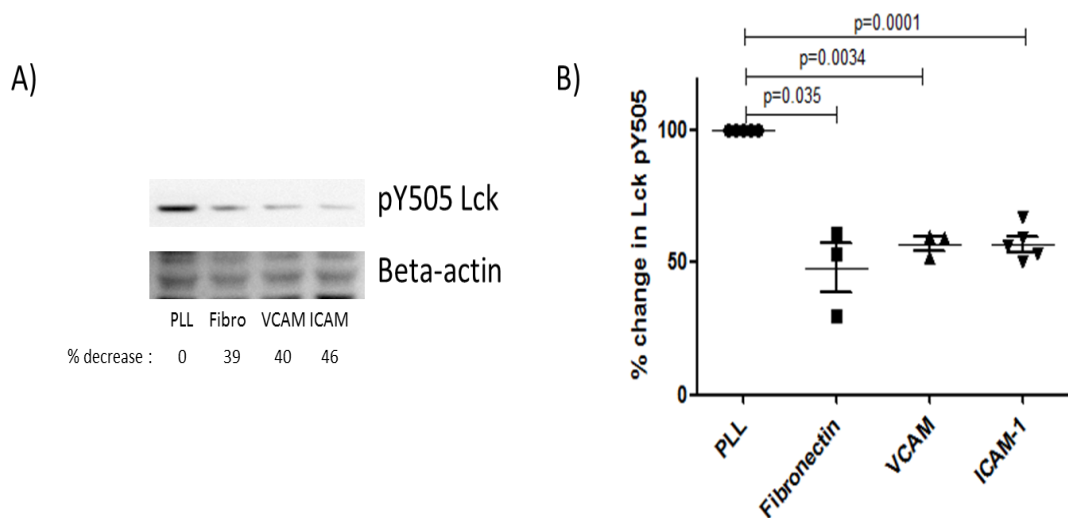

Figure 3.11: Lck is dephosphorylated at the inhibitory pY505 residue when T cells migrate on various integrin ligands (A) PHA stimulated T cells cultured in IL-2 for 8-10 days were used to prepare total cell lysates. Cells lysates prepared from cells migrating over different integrin ligands – fibronectin (Fibro), VCAM-1 and ICAM-1 (or PLL) were probed with an antibody that recognises pY505 phosphorylation on Lck. B) Densitometric quantification of pY505 dephosphorylation, representative of at least 3 independent experiments.

3.4.6 Csk and Lyp dissociate from PAG when T cells migrate on ICAM-1

When investigating the PAG-Csk complex in immobilised and migrating cells, it was of note that the dissociation of this complex was not complete. Instead a pool of Csk evidently remains associated with PAG, even in migrating cells, but to a lesser extent than that of immobilised cells, suggesting that Csk may still be regulating certain inhibitory signals in migrating cells. Lyp and Csk immunoprecipitation experiments suggested that Lyp and Csk were more complexed in migrating cells. An outstanding question was whether or not Csk-Lyp complexes were more associated and docked onto PAG in migrating cells, or whether this complex was acting independently of PAG. PAG immunoprecipitation recapitulated the modest dissociation of Csk (Figure 3.12A and B) with a 30% decrease in Csk-PAG association, but demonstrated a more striking dissociation of Lyp, suggesting that Lyp positioning at the membrane was independent or only partially dependent on PAG in migrating cells, and that the Lyp-Csk complex that is formed when LFA-1 is engaged might be retained at the membrane by some other mechanism (Figure 3.12C and D). Alternatively, the Lyp-Csk complex may not be localised specifically at the membrane but instead may operate within the cytoplasm compartment.

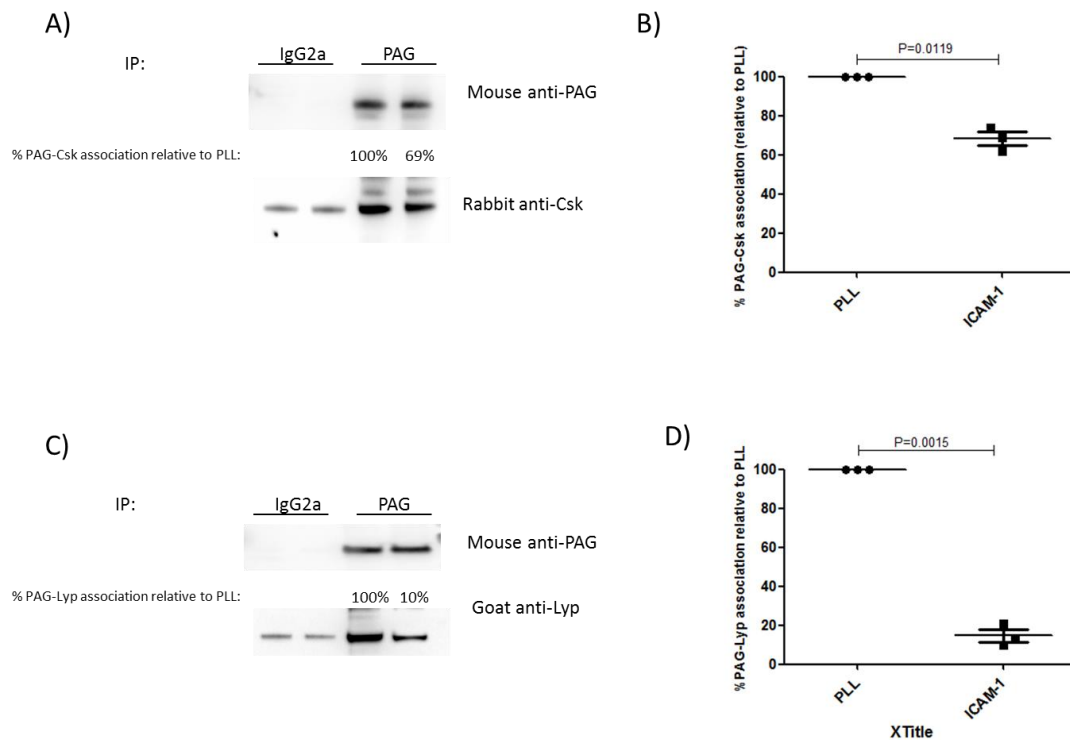

Figure 3.12: Lyp and Csk dissociate from PAG when T blasts migrate on ICAM-1 A) T cells that had been stimulated with PHA (1 μ g/mL) for 48 hours and then cultured in IL-2 (Proleukin-20ng/mL) for a further 8-10 days were immobilised on PLL (0.01%) or were allowed to migrate on ICAM-1 (4 μ g/mL) for 30 mins in 6 well dishes. After 30 mins, excess cells were aspirated and 1mL lysis buffer containing 1% Triton X-100 40mM NOBGP was added to well 1 where cells were lysed and then the lysis buffer was transferred to well 2 until all cells attached to the 6 wells in the dish had been lysed in a

total of 1mL lysis buffer. The lysates from ICAM-1 and PLL were split (500µL/Eppendorf) and either a non-specific isotype or mouse anti-PAG was used for the immunoprecipitation overnight at 4C. The following day Protein G magnetic beads were added to each Eppendorf for 30 mins at 4C. The beads were then washed 3X in standard lysis buffer containing 1% Triton and the antibody was eluted from beads with 20uL of boiling sample buffer. The eluates were resolved by SDS-PAGE and transferred to PVDF where they were probed rabbit anti-Csk or mouse anti-PAG. B) B densitometric analysis of 3 experiments as in (A). C) Immunoprecipitation as in (A) only goat anti-Lyp was probed for followed by mouse anti-PAG D) densitometric analysis of (C). data re representative of 3 independent experiments for (A) and (B).

3.5 Summary of the dynamics of the Lyp/Csk/PAG complex

Using antibodies that can be utilised in the context of two different techniques, immunofluorescence and immunoprecipitation/blotting, it has been demonstrated that Lyp can reside near or at the plasma membrane where it may co-localise with Csk and PAG, or in the cytoplasm where it colocalises with Csk. The Lyp/Csk/PAG complex was notably co-localised in cells immobilised on poly-L-lysine. In contrast, migrating cells appeared to show high co-localisation of Csk and Lyp, whereas PAG staining appeared to be more diffuse, with some co-localisation between Lyp/Csk/PAG at the leading and lagging edge of migrating T cells. A biochemical analysis demonstrated that, upon integrin signalling, PAG and Csk partially dissociate which in turn was correlated with a 40% decrease in the Csk target pY505 indicating conformational changes in Lck. Alterations in phosphorylation at the activatory tyrosine residue within the kinase domain could also be detected, with pY394 being at least twice as phosphorylated, indicating changes in catalytic potential. Moreover, the association of Lyp, Csk and PAG appears to change when T cells migrate on ICAM-1. At this point the working model is that some Lyp is associated with the PAG/Csk complex in immobilised cells, and following integrin ligation Csk dissociates partially from PAG and associates with Lyp, with the majority of Lyp in migrating cells not being PAG bound.

Discussion

This chapter sought to answer questions pertaining to the expression of Lyp in untouched versus activated T cells, the localisation of Lyp in migrating T cells and the dynamics of the Lyp-Csk-PAG signalling complex.

The expression of PTPN22 differs between untouched and activated T cells in both mouse (www.immgen.org) and man (Figure 3.1). In activated T cells, the expression of PTPN22 increases, which might suggest that following T cell priming, the signal transduction network is differentially regulated. Interestingly, *Ptpn22* knockout mouse T cells display signalling perturbations that are confined only to the effector/memory T cell population, although it is of note that more recent studies using transgenic T cells that can discriminate between high and low affinity peptide complexed with TCR seem to suggest that naïve CD8⁺ T cells from *Ptpn22* knockout mice are more readily activated than their *Ptpn22* sufficient counterparts (Hasegawa, Martin et al. 2004, Salmond, Brownlie et al. 2014). This difference in the signalling threshold observed in T cells from *Ptpn22* knockout mice is associated with an expansion of effector/memory T cells as mice age. The clonality, and therefore the origin of this expansion, remains unclear, and could be due to differences in T cell selection, hyperactive signalling through the TCR in naïve T cells leading to effector/memory generation, the hyperresponsive signalling in effector/memory T cells or differences in survival. Although it is tempting to speculate that the difference in Lyp expression between naïve and effector/memory T cells is important, the abundance of a protein does not necessarily correlate with its importance in any given biological process, and the fact

that it is expressed at all may be more significant than the amount of specific protein per cell.

In human T cells, I show that PTPN22 is upregulated at the protein level following TCR engagement or polyclonal stimulation of T cells with PHA. Stimulation via the T cell receptor consistently led to Lyp upregulation after 48 hours of receptor stimulation, the point at which the cells begin to proliferate and become true effectors. This might suggest that the upregulation of Lyp is not important during the priming process itself but rather as the cells become effector T cells. The issue of Lyp upregulation requires further clarification, as the T cells assayed in these experiments were unmanipulated and of a mixed population, consisting of naïve, effector and memory cells and demonstrated basal levels of Lyp expression in the absence of stimulation. Thus, understanding exactly which subsets of T cells Lyp is expressed in and to what level may be useful; further investigations would be required to validate the significance of expression profiles across T cell subsets in the context of specific signalling pathways. My initial attempts to demonstrate expression of intracellular Lyp in fixed and permeabilised T cells suggests that flow cytometry would be a productive way to explore expression in different (and rare) cell subsets.

Given that Lyp is upregulated in T cell blasts, and that an inside-out signal is required to activate integrins such that they can bind their ligand, activated T cells were used for all subsequent assays. Immunofluorescence was used to document the localisation of Lyp, Csk and PAG in fixed T cells immobilised on PLL or migrating on ICAM-1. Lyp and Csk have been shown to interact directly, with the first poly-proline binding domain of Lyp, PLPXR, being important but not completely defining of this interaction (Ghose, Shekhtman et al. 2001). Csk is a kinase that negatively regulates Src family kinases by

phosphorylating an inhibitory tyrosine residue at the C-terminus of any given Src family kinase leading to intramolecular interactions that inhibit binding (Nika, Tautz et al. 2007). Thus the binding of Csk and Lyp has been viewed conventionally as a co-operative one, leading to synergistic regulation of signalling downstream of the TCR (Cloutier and Veillette 1999). Staining patterns of Lyp and Csk in non-migrating versus migrating cells differed considerably, with non-migrating cells showing colocalisation of these two proteins at the plasma membrane and within the cytoplasm. In contrast, the Lyp-Csk staining patterns in migrating cells demonstrated that Lyp and Csk were localised to both the leading and lagging edge of migrating T cells where they appeared to co-localise. The extent of colocalisation of these two signalling intermediates in both migrating and non-migrating cells might suggest that they were interacting under both conditions. Accordingly, the extent of this interaction was investigated in co-immunoprecipitation experiments. In these experiments, Lyp and Csk were shown to interact constitutively, an interaction that was increased when T cells migrated. Thus, despite Lyp and Csk being highly co-localised in non-migrating cells, there was a two fold increase in Lyp-Csk complexing when T cells migrate. These results raised the interesting possibility that whilst Lyp and Csk in non-migrating cells are interacting, there was some mechanism in place somehow limiting this interaction, and following integrin engagement, these two signalling intermediates could more readily associate. The mechanism responsible for Csk-Lyp interaction regulation is discussed further in chapter 6.

Csk has been shown to interact with PAG, a hydrophobic protein that is palmitoylated and abundant in liquid ordered plasma membrane phases (Hrdinka and Horejsi 2013). The function of PAG is to localise Csk in rafts where it tonically negatively regulates Src

family kinase members (Bergman, Mustelin et al. 1992). The tonicity of this regulation is exemplified by Weiss and colleagues who engineered a genetically encoded, acutely inhibitable Csk construct that was highly susceptible to catalytic inhibition by a PP2 analogue (Wang, Kadlecik et al. 2010, Schoenborn, Tan et al. 2011). These studies demonstrated that upon the acute inhibition of Csk in resting T cells, proximal signalling pathways involving Src and Syk family kinase members were activated, in the complete absence of receptor stimulation, suggesting that negative signalling is actively maintaining pathways in an “off” state. The regulation of Csk also differs from that of other Src Family Kinase members in that it has no inhibitory or activatory tyrosine motifs that are phosphorylated to regulate catalysis and conformation. Instead, the binding of an SH2 domain on Csk to pY317 on PAG affords increased catalysis. Thus, PAG may regulate Csk in at least two ways: by localising Csk to rafts and by increasing catalytic potential in a spatially confined manner (Stepanek, Draber et al. 2014).

Staining patterns of PAG and Csk were as expected, with high levels of co-localisation at the plasma membrane in non-migrating cells, completely in line with the role of this complex in tonically regulating Src activity levels within rafts. Under conditions of migration, Csk expression patterns were more asymmetric in distribution, with staining mainly at the front and the back of the cell. PAG, on the other hand, was much more diffusely localised with some focus at the front of the cell. It was also noted that PAG staining was punctate, indicating small islands of protein staining which presumably was occurring in rafts.

Together, these results might suggest that PAG and Csk are less associated in migrating T cells, an observation that was confirmed by co-immunoprecipitation experiments

demonstrating a dissociation of PAG and Csk when T cells migrated. Curiously, only a small but significant decrease in PAG-Csk could be detected, with a 30% decrease in the association as compared to non-migrating cells. What this might suggest is that the pool of Csk still associated with PAG may play an active but distinct role in regulating active signalling emanating from the integrin when T cells migrate. The dissociation of Csk from PAG correlated well with changes in phosphorylation of Lck, a Src family kinase known to bind directly to LFA-1 when engaged by ICAM-1. The decrease in Lck phosphorylation at pY505 might directly implicate a change in Lck-Csk interactions or the activation of a phosphatase that antagonises phosphorylation of Lck at pY505 via dephosphorylation favouring a productive signal transduction event. Indeed, PAG was found to be less phosphorylated in migrating cells, although the precise tyrosine residue(s) contributing to this change in phosphorylation was not investigated further. I speculate that residue Y317 will be implicated given its previous identification as a Csk binding site. A picture started to emerge suggesting that perhaps one of the most proximal events occurring in LFA-1 signal transduction was the dissociation of Csk from PAG, allowing for local activity of Lck and the binding of activated Lck to LFA-1. The Csk-PAG dissociation correlated well with Lyp-Csk complexing. This led to the idea that PAG and Csk were more complexed in non-migrating cells, and following integrin ligation this complex dissociated, and Csk then complexed with Lyp.

Immunostaining patterns of Lyp largely recapitulated that of Csk, where in non-signalling cells Lyp and PAG colocalised mainly at the membrane, and in migrating cells at the front of the cell. Co-immunoprecipitation experiments of PAG indicated that PAG dissociated from Lyp and Csk, further supporting the idea that the complexing of Lyp and Csk was, surprisingly, not occurring on PAG itself in migrating T cells. There

was however a residual amount of Lyp (~10% of PLL) that could be co-immunoprecipitated with PAG in migrating cells, indicating that a pool of Lyp was still associated with PAG, albeit a much smaller pool than that of Csk (~70% of PLL). These experiments revealed that Lyp, Csk and PAG can form a heterotrimer complex, by interacting either directly, or indirectly, and that this trimer appears to have more operational significance in non-signalling cells, where Lyp and Csk are more complexed with PAG. However, the complexing between Lyp and Csk increases when T cells migrate, and this is correlated with both Lyp and Csk being released from PAG, suggesting that Csk and Lyp were interacting in a distinct cellular compartment independent of PAG. Future studies need to clarify whether Lyp is truly complexing with PAG via Csk.

Taken together these results reveal a dynamic interaction between the Lyp-Csk-PAG complex. A situation can be envisaged where the selective interaction between these intermediates leads to the concerted regulation of T cell signal transduction pathways, both when cells are signalling and when they are not. Perhaps of more interest than understanding interaction versus dissociation of the Lyp-Csk-PAG complex is the switch in signalling intermediate behaviour that facilitates a signal that can be interpreted by a cell. In considering the operational changes in Lyp, Csk and PAG, and the possible importance of these signalling intermediates in regulating positive signals, it is tempting to speculate that under certain conditions these intermediates change their behaviour to meet the contextual requirements of a signalling pathway, independently of associating with one another. In other words, it is not a case of “on” or “off” but rather a spectrum of activity and interactions governed by spatial, temporal and post translational cues. To truly understand the complex dynamics, more in depth live cell

studies that can measure interaction between these signalling intermediates in real time are required. For my project, net changes in the interaction of Lyp, Csk and PAG have been identified, which for the first time implicates these proteins in regulating integrin signalling and T cell migration.

Chapter 4
The regulation of T cell migration by PTPN22/Lyp

The imaging studies and biochemical data described in Chapter 3 pointed towards a role for the Lyp, Csk and PAG complex in regulating LFA-1 dependent T cell migration. An important experimental goal was to validate this finding at a functional level by studying how manipulation of Lyp expression, or the expression of autoimmune disease associated Lyp mutants, regulated T cell migration. A second important objective was to investigate how deficiency of PTPN22/Lyp perturbed integrin specific signal transduction, with the majority of studies focusing on signalling through the $\alpha\text{L}\beta\text{2}$ integrin LFA-1.

4.1 The effects of Lyp knockdown on static T cell migration

Lyp is upregulated in T cell blasts (see Figure 3.1, Chapter 3). To study the role of Lyp in the migration of activated human primary T cells, knock down of Lyp was attempted using two pools of siRNA derived from two different suppliers targeting different residues within the mRNA transcript (Figure 4.1); scrambled siRNA was used as a negative control. Activated T cells, generated following PHA stimulation and propagation with IL-2 for up to 14 days, were transfected with Lyp specific or control siRNA by AMAXA technology (as described in Chapter 2). After 48 hrs cells were harvested and whole cell lysates prepared prior to Western blotting with anti-Lyp antibodies to confirm the efficiency of Lyp silencing.

Figure 4.1A shows a representative blot of cell lysates derived from cells subjected to Lyp knockdown; anti-tubulin blots served as protein loading controls. This experiment

indicated that, based on comparative densitometry of Lyp and tubulin specific bands, the siRNA pools reduced Lyp expression by between 40% and 48% respectively. Flow cytometry experiments indicated that knockdown of Lyp had no effect on the expression of LFA-1 (Figure 4.1B).

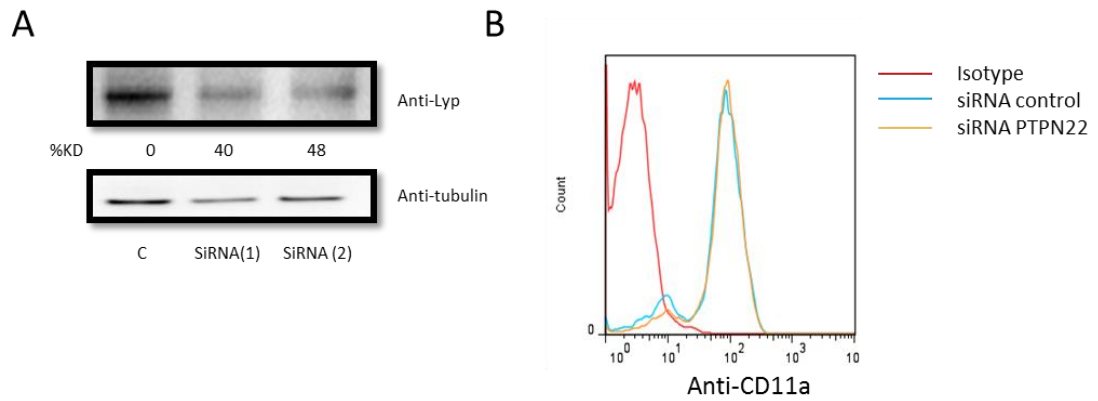

Figure 4.1: PTPN22 specific siRNA reduces Lyp expression by 40-48% in activated human T cells, but not LFA-1 expression. A) Primary T cells were stimulated for two days in PHA and then transfected with siRNA using the AMAXA system. Knockdowns were confirmed by western blotting. B) LFA-1 expression on Lyp knockdown cells was assayed by FACS using a specific cd11a antibody. Representative of 3 independent experiments

Parallel experiments using the same cells were undertaken to explore the effects of Lyp knockdown on migration of T cells on glass slides coated with ICAM-1Fc. Cells were plated at a density of 3×10^5 /ml and allowed to equilibrate onto glass slides at 37°C for 10 mins. Migration of individual cells was then monitored for 20 minutes by time lapse microscopy. Raw data derived from single cell tracking experiments of T cells transfected with control (n = 20 cell tracks) or Lyp siRNAs (n = 18) is shown in Figure 4.2A, and the speeds derived from analysis of multiple tracks of cells transfected with control or one of two Lyp siRNA pools shown in Figure 4.2B. Lyp knockdown was associated with significantly faster migration speeds than T cells expressing a scrambled control siRNA (scrambled, 0% knockdown – 12.2 μ m/min; siRNA1, 40% knockdown – 14.69 μ m/min; siRNA2, 48% knockdown – 17.5 μ m/min). Interestingly, the speeds of migration correlated with the percentage knockdown, with the higher percentage knockdowns being associated with increased speeds of migration (Figure 4.2B).

To corroborate these data, *PTPN22* deficient mouse T cells were assayed under similar conditions using mouse ICAM-1-Fc, and were compared to *PTPN22* sufficient T cells. *PTPN22* deficient mouse cells migrated faster than their wildtype counterparts (Fig 4.2C) with speeds of migration increasing from 14 μ m/min for wild type T cells compared to 16.2 μ m/min for *PTPN22* deficient T cells.

Together these results provided the first indication that the protein tyrosine phosphatase Lyp is a negative regulator of integrin dependant migration in T cells.

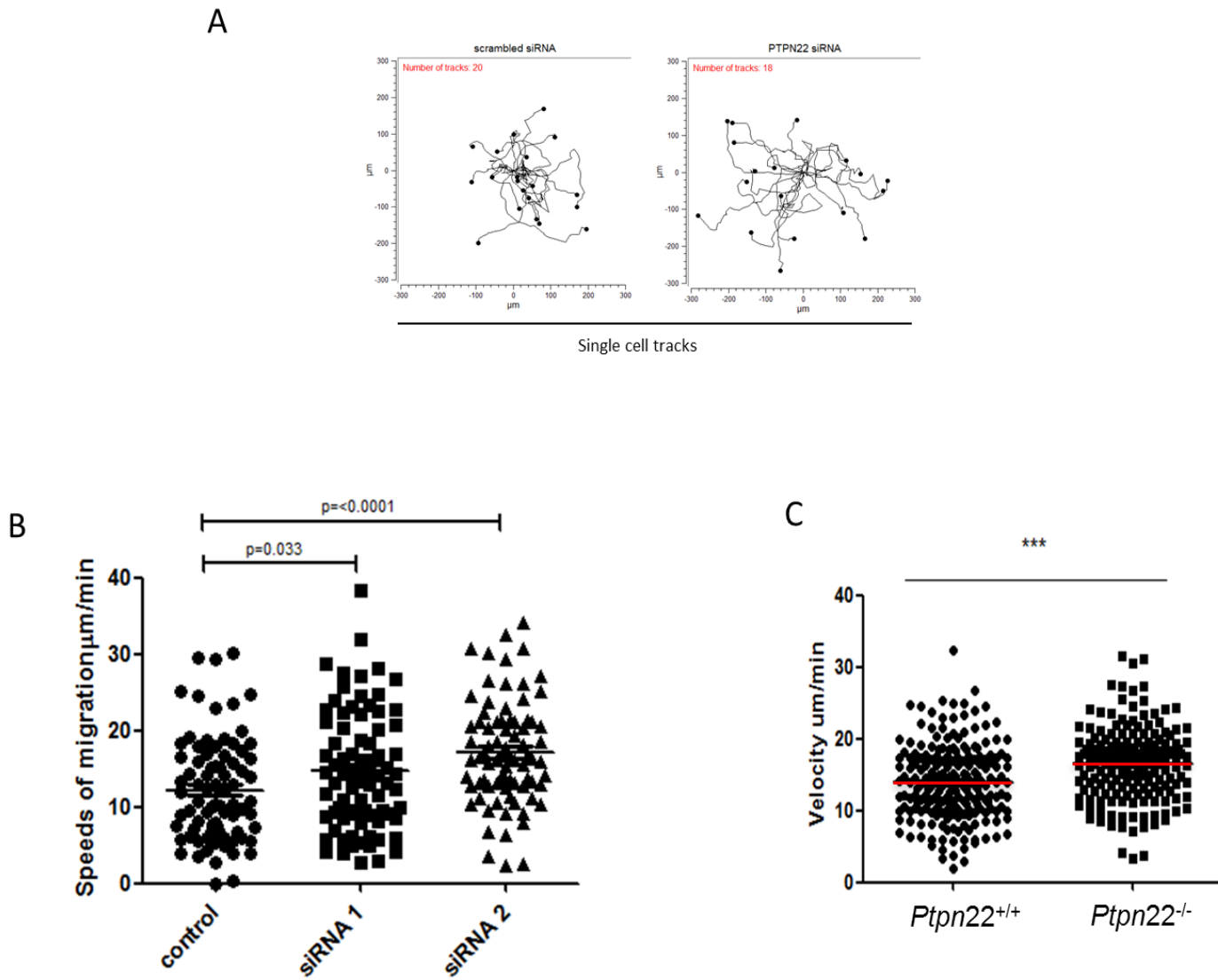

Figure 4.2: Lyp deficiency increases LFA-1 dependent migration in human and murine T cells under static conditions. A) T blasts were transfected with siRNA directed at Lyp. Cells were plated onto ICAM-1 and videos were recorded for 20 mins, 4 frames/min, after which the cells were tracked using Image J cell tracker plugin and plotted in Ibi migration software. B) Individual cell velocities were plotted from experiment 4.1A+B and experiment 4.2A and C) PTPN22 deficient mouse T cells were tracked and velocities calculated. Representative of 3 independent experiments with at least 60 tracks per experiment.

4.2 The catalytic activity of Lyp is required to regulate T cell migration

Given that Lyp knockdown increased the speeds at which cells migrate, the consequence of overexpression was next investigated in order to further confirm that Lyp may be negatively regulating integrin signals. To do this, LypR620-GFP and LypW620-GFP fusion protein constructs were generated. Two additional control constructs were generated. First, a Lyp mutant was generated containing an alanine mutation in the catalytic domain cysteine residue, C227A. C227 confers the ability of the phosphatase domain to catalyse the removal of phosphates from target proteins. Secondly, a GFP “empty vector” was also employed to ensure that the fluorescent protein itself was not responsible for any differences observed in migration.

To confirm that similar levels of Lyp-GFP fusion protein were expressed in transfected T cells, cells were lysed and immunoblotted with anti-Lyp antibodies to detect both endogenous Lyp and Lyp-GFP. In addition, T cells expressing the R620, R620W or GFP alone and migrating on ICAM-1 were imaged to examine whether there were any differences in localisation that might account for functional differences observed between R620 and R620W. The confocal images shown in Figure 4.3A indicate that Lyp-GFP expression patterns appear similar for Lyp-R620 and Lyp-W620 expressing cells. Figure 4.3B shows that endogenous Lyp expression is comparable in T cells expressing GFP alone, Lyp-R620-GFP, Lyp-W620-GFP and Lyp-C227A-GFP (lower MW band), and that Lyp-GFP expression, seen resolving at a higher molecular weight and detected with the same anti-Lyp antibody, was also similar in cells overexpressing the R620, R620W and C227A constructs.

Tracking of GFP positive cells by time lapse microscopy revealed that migration of T cells overexpressing Lyp-R620 was dramatically reduced when compared to cells overexpressing GFP or the catalytically inactive Lyp-C227A mutant (Figure 4.3C). When transfected with GFP alone, T blasts migrated at an average speed of 10.25 μ m/min, which was reduced to 2.7 μ m/min when overexpressing R620, a result which was highly statistically significant ($P=0.0001$). When transfecting T blasts with Lyp-W620, speeds of migration were reduced to 5.1 μ m/min. Thus, Lyp-W620 T cells were migrating almost twice as fast as cells transfected with the wild type construct. The Lyp-W620 construct reduced speeds of migration significantly as compared to the GFP control ($P=0.0004$), suggesting that Lyp-W620 could still influence the speed at which T cells migrate, but less efficiently than the wild-type construct. Importantly, there was a statistically significant difference between the Lyp-R620 and Lyp-W620 construct in terms of speeds of migration ($P=0.013$). The catalytically inactive phosphatase construct C227A behaved in a comparable manner to the GFP control, indicating that the phosphatase activity of Lyp is required to regulate cell migration ($P=>0.05$).

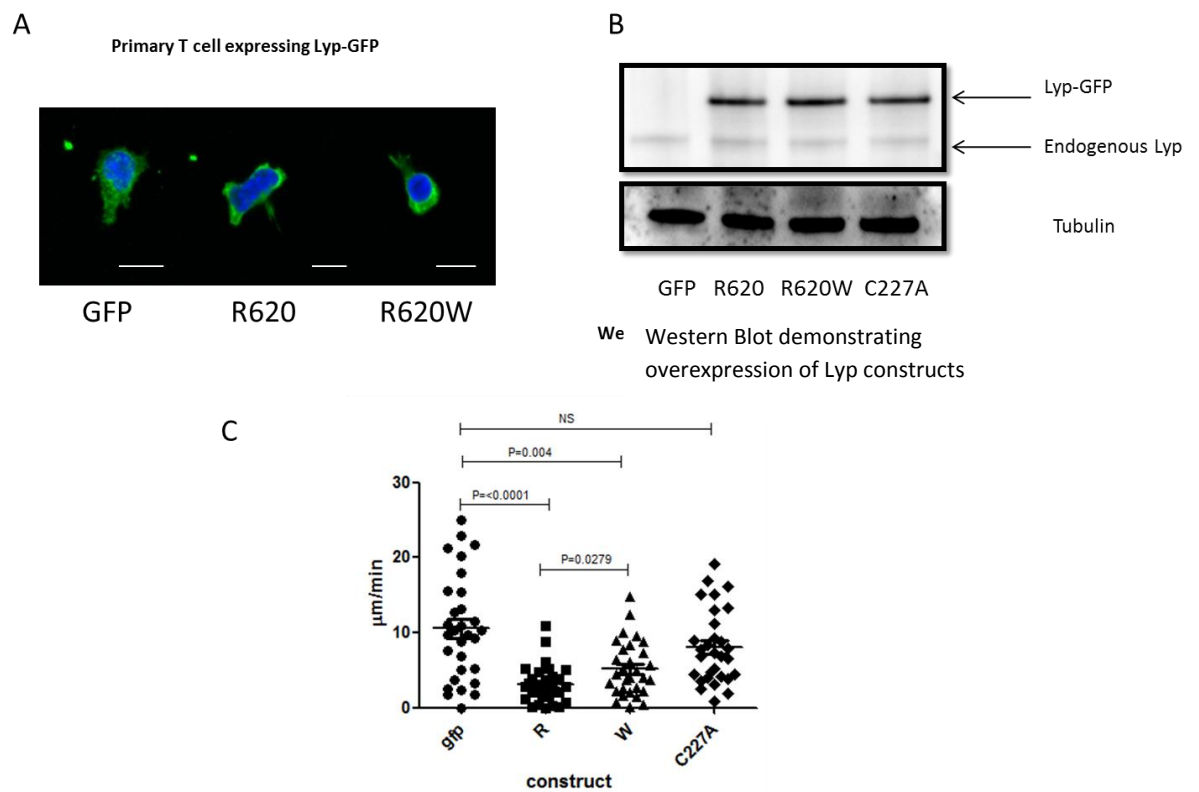

Figure 4.3: The catalytic activity of Lyp is required to regulate T cell migration in static conditions A) Confocal images of Lyp-GFP transfected T cells migrating on ICAM-1 demonstrating no gross differences in Lyp localisation between the R620 and R620W construct when T cells migrate. Scalebar 10μm B) T blasts were transfected by AMAXA with Lyp constructs or GFP alone, overexpression was confirmed by Western Blot and C) Transfected T blasts velocities from (B) Representative of at least 3 independent experiments.

These experiments were then repeated using GFP positive T cells purified by cell sorting; GFP expression profiles are shown for each transfectant in Figure 4.4A. An overlay of the Lyp-R620 and Lyp-W620 is shown, demonstrating comparable transfection efficiencies, and no differences in expression level as determined by flow cytometry (Figure 4.4A and B). The median fluorescence of the cells was also then calculated (Figure 4.4C). The data indicated that cells transfected with Lyp constructs expressed Lyp and Lyp mutants at comparable levels. Cells that were mock transfected, transfected with GFP alone or transfected with a catalytically inactive Lyp migrated at comparable speeds that were not significantly different (see Figure 4.4D: mock=7.1 μ m/min; GFP alone=7.2 μ m/min; C227A=6.3 μ m/min), in keeping with previous results. As in the experiments using unsorted cells, transfection with the catalytically active wild type Lyp-R620-GFP construct led to significantly lower speeds of migration of 2.2 μ m/min, and was significantly different from the mock, GFP alone and catalytically inactive mutant ($P < 0.0001$). The Lyp-W620 construct also slowed speeds of migration down significantly as compared to the controls ($P = 0.016$) with an average speed of 4.9 μ m/min. Importantly, a statistically significant difference in the speeds of migration between Lyp-R620 and Lyp-W620 could be observed where $P = 0.02$. These experiments, when interpreted in combination with the knockdown experiments, provided further support to suggest that Lyp is a negative regulator of LFA-1 dependent T cell migration, and that the Lyp-W620 mutant was unable to regulate LFA-1 dependent migration in T cells in the same way as efficiently as the wild type construct. Thus, the Lyp-W620 operates as a loss-of-function variant when overexpressed on an R620 expressing background.

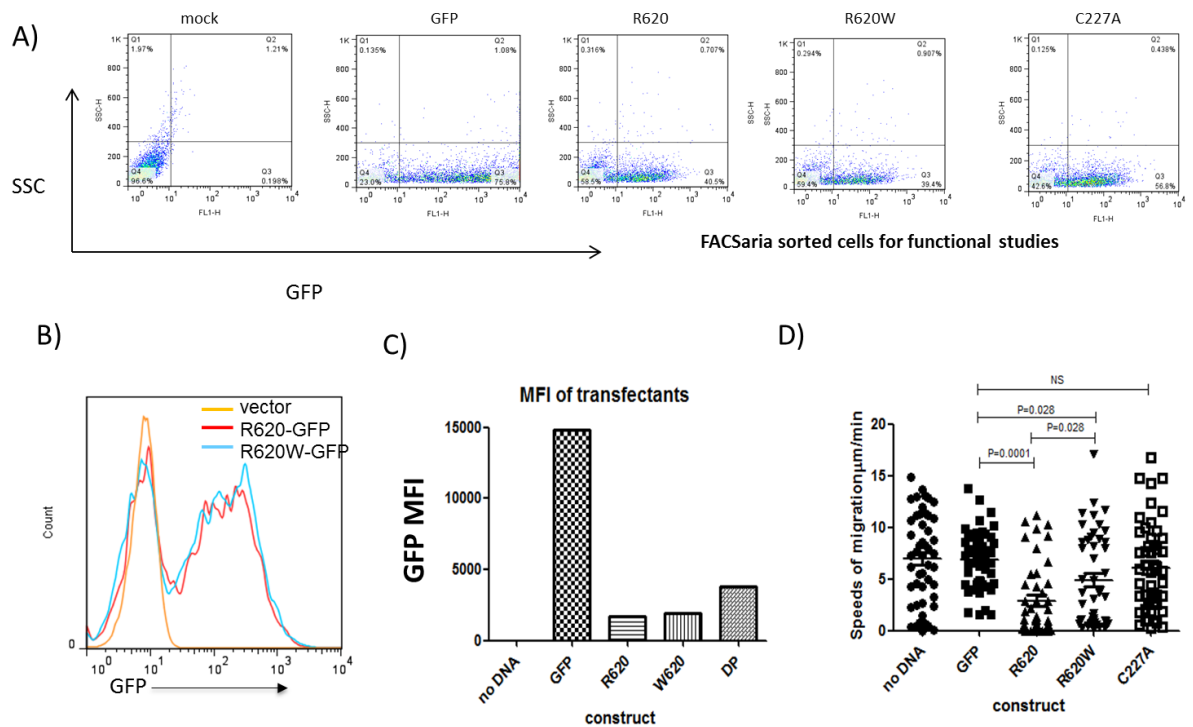

Figure 4.4: Lyp expressing T cells, sorted for GFP expression confirm that Lyp is a negative regulator of T cell migration. A) Plots demonstrating GFP positive transfected T cells that were sorted for static migration assays B) Histogram demonstrating comparable expression of both R620 and W620-GFP Lyp C) Histogram demonstrating comparable MFI between different constructs D) Velocity of cells transfected with GFP or Lyp constructs migrating on ICAM-1

4.6 Functional analysis of T cells from *PTPN22* genotyped donors

The experiments reported to this point describe the effects of manipulating Lyp expression on the migration of primary human T cells, where endogenous Lyp gene expression was targeted and knocked down, or Lyp was introduced (and overexpressed) by transfection of primary T cells using expression vectors encoding wild type Lyp. To understand whether or not a single point mutation in the binding domain of Lyp might lead to a specific phenotype in *PTPN22* genotyped individuals, we employed random migration assays, adopting the assays described above, to examine the speeds at which peripheral blood T cells from individuals carrying homozygous Lyp-W620 mutations (GG) migrated, as compared to the migration of T cells from individuals who do not harbour the mutation (Lyp-R620 homozygous AA carriers). We chose to adopt this initial approach using extreme genotypes in the belief that this would be more likely to uncover a reproducible phenotype than experiments using T cells from carriers of the heterozygous mutation.

Peripheral blood mononuclear cells were purified from consenting donors recruited to the NIHR TwinsUK Bioresource. This is a large Bioresource of more than 12,000 twin pairs of whom ~ 6,000 have undergone genome wide genotyping. This permits the identification of rare genotypes, such as the *PTPN22* W620 homozygous genotype (which has a frequency of < 1% in the healthy population). The TwinsUK Bioresource allowed us to source 57 of these relatively rare homozygous donors. Cells were stimulated with PHA for 2 days and IL-2 for 5 days prior to functional analysis. In each experiment, paired samples were tested (Lyp-R620 homozygote versus Lyp-W620

homozygote), matched for age and gender, and subjected to migration on ICAM-1 and time-lapse microscopy, as described above.

Strikingly, in 4 out of 5 experiments the migration assays demonstrated that T cells homozygous for the Lyp-W620 mutation migrated significantly slower than control cells not harbouring the W620 mutation. Single cell tracks are shown in Figure 4.5 ($P < 0.001$ for all but 1 pair of donors), and speeds shown in Figure 4.6. Interestingly, the results from pooled data are shown in Figure 4.7, where the analysis of single cell tracks from ~ 350 cells per genotype, expressed as speeds in $\mu\text{m}/\text{min}$, are presented. Again, the speed of migration of T cells from GG donors was on average $10.52\mu\text{m}/\text{min}$, significantly slower than that of AA donors, which averaged at $7.4\mu\text{m}/\text{min}$. Thus, T-cells from individuals homozygous for the R620W mutation migrated slower.

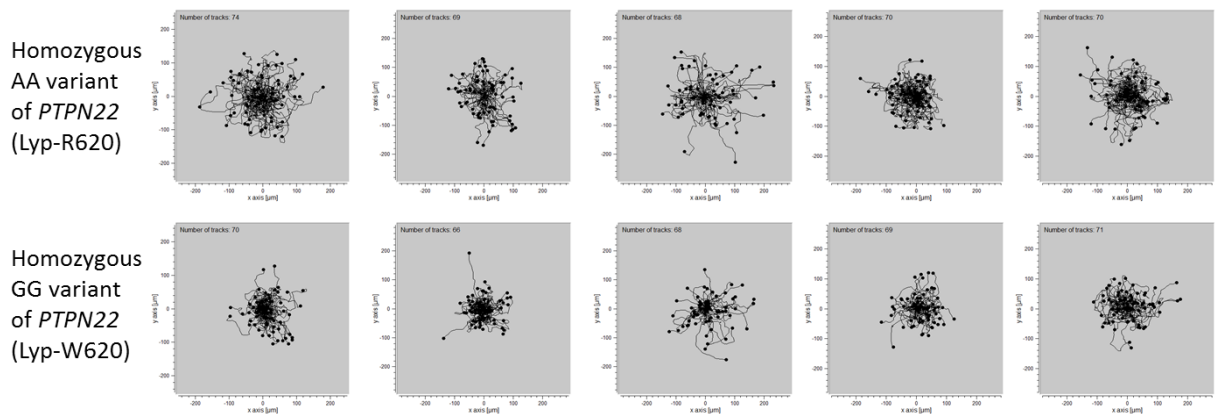

Figure 4.5: Static migration studies on genotyped cells. Genotyped cells were stimulated with PHA for 2 days, expanded in IL-2 for 5 days and used for static migration studies on ICAM-1 by timelapse microscopy (20 mins, 4 frames/min). Top panel represents R620/R620 individuals, bottom panel R620W/R620W individuals. Representative of at least 60 cells per genotype, total of 10 genotypes (5 R620/R620 and 5 R620W/R620W)

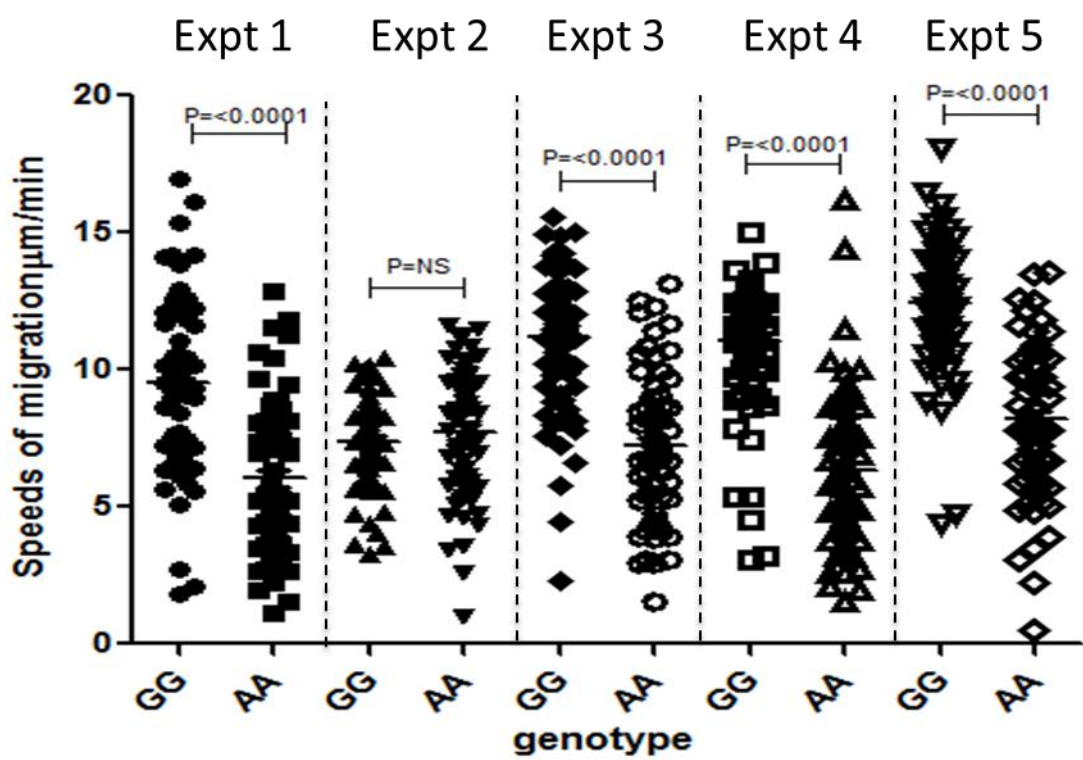

Figure 4.6: Static migration studies on genotyped cells. Quantification of individual cell velocities from figure 4.5. Experiments are paired, and matched for age and gender.

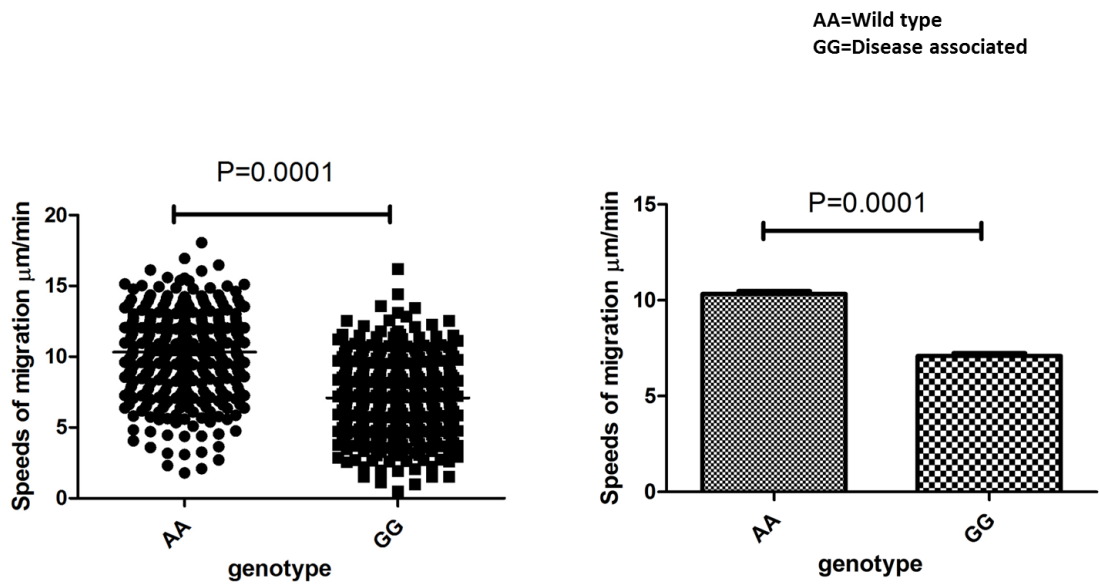

Figure 4.7: Lyp-W620 (GG) expressing T cells migrate slower than Lyp-R620 (AA) expressing cells. Data from T cells of individual donors from experiments shown in Fig 4.6 were pooled and represented as single plots. (A) Dot plot analysis of 351 “AA” variant” and 344 GG variant expressing T cells, and (B) data depicted as histogram plots (P = 0.0001).

In summary the data described in this chapter demonstrate:

1. Lyp knockdown increases speeds of migration, with LFA-1 levels remaining unaffected
2. Overexpressing R620-Lyp reduces the speeds at which T blasts migrate
3. The catalytic activity of Lyp is required to regulate T cell migration
4. R620W-Lyp cannot regulate migration in the same way as R620-Lyp

Discussion

Using manipulated (silencing/overexpression/knockout murine cells) and unmanipulated systems (genetically encoded human variants) this chapter sought to better understand the function of Lyp with respect to its ability to regulate signal transduction through LFA-1.

The migration assays employed in these studies were performed under static conditions. Ideally, they should be performed in a system where mechanical force is applied against the cell to recapitulate more faithfully adhesion under blood flow in the vasculature, where LFA-1 function has been demonstrated to be non-redundant (Alon and Dustin 2007). These experiments are currently underway in the laboratory. It was clear however, under static conditions, where cells moved over a 2D surface coated with ICAM-1, that a migratory programme was initiated following integrin engagement, demonstrated by polarisation and increased speeds of migration.

Perhaps some of the limitations of the shear flow systems are the lack of biochemical assays that can be used to mirror the functional responses observed. To this end, I performed migration under static conditions and used the exact same experimental conditions used for functional studies to perform a comprehensive biochemical dissection of integrin signalling. In this way it was possible to extrapolate the functional outcomes observed with my biochemical studies, as described in Chapters 3, 5 and 6.

The manipulation of Lyp expression in T cells revealed that when Lyp gene expression was silenced (meaning that total Lyp expression of Lyp protein was reduced), cells migrated faster as compared to control cells. These studies were undertaken in an experimental system involving the use of transfection to transiently perturb Lyp

expression in primary human T blasts. Lyp silencing resulted in a modest decrease in protein of ~45% indicating that more than half of what is normally expressed was still present. Despite this, an increase in migration was observed. Using T cells derived from a mouse deficient for *Ptpn22*, the same phenotype as that observed when silencing Lyp in primary human T cells was noted; *Ptpn22* deficient mouse T cells migrated faster when compared to their wild type *Ptpn22* sufficient counterparts. Thus, in the acute setting of Lyp silencing (human T blasts) and a more long term model for total lack of expression (murine T cells) the speeds at which T cells migrated were increased when Lyp was either partially or totally removed from the system. Given the modest knockdowns in human cells, and the possibility of compensatory effects by other phosphatases in mice during development of the organism, a system where Lyp can be more efficiently silenced would be interesting to study the functional effect of Lyp deletion in an acute setting. Such systems, including zinc-finger silencing technology that can target and silence a genetic locus in both an acute and permanent manner would be of interest.

Overexpression studies demonstrated that increasing protein levels of wild type Lyp in primary T cell blasts decreases their speeds of migration. In these assays, Lyp constructs containing a GFP C-terminal tag downstream of the binding domain of Lyp were generated by PCR and cloned into a vector containing a CMV promoter. The CMV promoter is a powerful promoter allowing for large increases in expression of total Lyp protein. The GFP-Lyp fusion proteins allowed for Lyp expression to be assayed at a single cell level by flow cytometry, as compared to the average overexpression of Lyp by immunoblotting of lysates derived from a large population of cells. Static migration assays were performed on either FACS Aria sorted cells or by tracking GFP positive cells

within a population of transfected cells with further confirmation of GFP positivity being provided by a western blot, which indicated a comparable amount of protein expression existed between the different constructs used. The results from both methods were similar, in that transfection of Lyp-R620 was able to reduce speeds of migration, while Lyp-W620 conferred reduced speeds of migration but not to the extent of R620-Lyp. Controls for these experiments included a GFP vector alone and a Lyp construct lacking any catalytic activity Lyp-C227A. The GFP alone and Lyp-C227A behaved in a comparable manner, suggesting that any effects seen as a consequence of overexpression of Lyp-R620 or Lyp-W620 in transfected T cells are likely to be dependent either on catalytic activity or the P1 binding domain of Lyp. One notable difference observed between these assays was the speeds at which cells migrated; it is possible that the “stress” of the sorting process may have contributed to decreased speeds of migration, although these decreases in speeds did not influence the pattern of migratory responses, according to transfectant.

By adopting an approach utilising T cells derived from individuals with genetically encoded mutations, it was possible to investigate the consequences of genetically encoded SNPs, circumventing the need to genetically manipulate cells using methods that could be prone to artefact. Unexpectedly, the results from these experiments indicated that T cells from individuals harbouring two copies of the disease associated Lyp-W620 encoding SNP, migrated at slower speeds than T cells from individuals who were homozygous for the Lyp-R620 encoding allele. This result was in direct disagreement with the results I had obtained in transfection experiments in which overexpression of the Lyp-W620 mutant by transfection led to faster speeds of

migration. These conflicting data may have been due to one or more reasons, including:

1. The transfection itself may alter the cell in such a way that the constructs do not lead to functional effects that faithfully reflect the biology.
2. The over-expression of Lyp-W620 in T cells that express normal levels of endogenous Lyp-R620 may not reproduce a scenario in the same way that transfection of Lyp-W620 into a Lyp deficient cell might.
3. The genotyped cells activate differentially when stimulated, leading to a phenotype secondary to that of activation rather than perturbations occurring via integrin signalling leading to the phenotype.
4. The conflicting results are in fact consistent with a model where loss of function of Lyp, arising from two copies of the Lyp-W620 encoding SNP, leads to unimpeded integrin signalling and adhesion of cells that is increased to a threshold that no longer permits the cells to move. Direct comparison of the migratory properties of RR, RW and WW expressing T cells would go some way to address this.

To conclude this chapter, I propose that in order to truly understand the functional effects of R620W-Lyp, a complimentary approach involving a biochemical dissection and super-resolution imaging of Lyp mutants and the organisation of integrins in mutant cells will be required in order to be able to ascertain pathway dynamics and protein organisation, the subject of which will be described in Chapters 5 and 6.

Chapter 5
Analysis of integrin signalling and its regulation by
PTPN22/Lyp

It is now well established that integrins can signal following engagement with counterligand. The signalling pathways evoked in response to integrin engagement appear to involve Src and Syk family kinases (Jakus, Fodor et al. 2007). A division of labour at the most proximal points in some signalling pathways has been postulated to exist between these two signalling intermediates, with Lck being the effector in T cells, phosphorylating ZAP-70 in response to receptor ligation. In other signalling pathways, Lck or ZAP-70 can act independently of one another. This chapter addresses in detail the dynamics of integrin signalling, focusing on the following specific aspects:

1. The phosphorylation of Lyp substrates in response to integrin ligation
2. The components of the Lyp signalling complex in cells following adherence to poly-L-lysine or ICAM-1.
3. The LFA-1 signallasome.
4. Perturbations of integrin signalling in *Ptpn22* deficient mice.

To date, a careful dissection of the phosphorylation status of signalling intermediates downstream of integrin has not been performed. We thus investigated some of the most proximal points in the integrin signalling cascade, focusing mainly on Lck, ZAP-70 and VAV. Lck and ZAP-70 have been shown to be directly dephosphorylated by Lyp at tyrosine residues pY394 and pY493 respectively. The putative tyrosine phosphorylated residue that Lyp dephosphorylates in Vav has not yet been mapped. We therefore used phospho-antibodies directed at specific residues in Lyp substrates to understand whether or not, during an integrin signal, target phospho-sites of Lyp are phosphorylated.

5.1 Optimising a protocol for integrin signalling

Signalling experiments can be performed in many different ways, which include using beads coated with ligand/antibody, agonistic antibodies (or crosslinking) or immobilised ligand/antibody on a coverslip. Each of these approaches has its advantages and disadvantages. For example, using an antibody cross-linking approach will invariably produce a large and robust signal, but the relevance of such an approach might be questioned due to artificial, non-reversible clustering of receptor that would not occur in a physiologic setting. In addition, small changes in signalling, that might occur as a result of a single base change might be missed because such a large and robust signal might lead to maximal responses that are not permissive to understanding the fine tuning of signal transduction regulation. Thus, cross-linking may be a viable approach in understanding signalling components involved in a given pathway, but does not reflect the composition or arrangement of signalling intermediates when a receptor is engaged by an actual ligand.

In this project, it was possible to use actual integrin ligands, thus bypassing the need to use agonist antibodies or antibody cross-linking. The integrin ligands – such as ICAM-1, VCAM-1 or fibronectin – were immobilised onto coverslips over which T cells can migrate. This approach greatly facilitated a biochemical dissection of actual migrating T cells, and in doing so, a more realistic reflection of signalling pathways evoked in response to integrin ligation. In addition, small changes in signalling might also be readily detected, which is important if more subtle differences in integrin signals are to be detected when comparing the effects of Lyp-R620 and Lyp-W620.

5.2 Integrins signal through a common module in T cells.

To investigate the phosphorylation status of Lck, ZAP-70 and Vav in migrating T cells, analysis of total cell lysates was performed by blotting with anti-protein as well as phospho-specific antibodies directed to these signalling intermediates. All of these candidates have been shown previously to interact either directly or indirectly with Lyp. By coating coverslips with different types of integrin ligands that bind to different integrins, it was possible to dissect whether or not there were any differences in signalling between two integrin subfamilies ($\beta 1$ and $\beta 2$ integrins). T cells were plated onto fibronectin ($\beta 1$), VCAM-1 ($\beta 2$) or ICAM-1 ($\beta 2$) coated cover-slips, and after 20 minutes excess cells were removed and the cells were directly lysed on the plate (Figure 5.1). As a control, cells were plated onto poly-L-lysine (PLL). Analysis of total cell lysates demonstrated that Lck is phosphorylated at residue pY394 upon integrin engagement, with a 2 fold increase in phosphorylation detected (Figure 5.1A and B), in good agreement with the data from Chapter 3 (Figure 3.10B). In addition, ZAP-70 was phosphorylated at residue pY493, and demonstrated a 3-4 fold increase in phosphorylation (Figure 5.1 C and D), while VAV was phosphorylated at pY174, with a 4 fold increase seen in phosphorylation (Figure 5.1 E and F). Thus, in response to integrin ligation, Lck, ZAP-70 and VAV are phosphorylated at residues that are associated with protein activation. Interestingly, Lck had a high level of basal pY394 phosphorylation, which increased modestly (~2 fold), but ZAP-70 and Vav appeared to undergo greater changes in inducible phosphorylation (3-5 fold). Activation, as determined by inducible phosphorylation of signalling intermediates, appears to be similar for the different integrin ligands tested, suggesting that signalling machinery is shared downstream of different integrin receptors.

Taken together, integrin signalling in T cells leads to activation of Lck, ZAP-70 and VAV, as determined by inducible phosphorylation. The temporal aspects of Lck, ZAP-70 and VAV phosphorylation were next investigated.

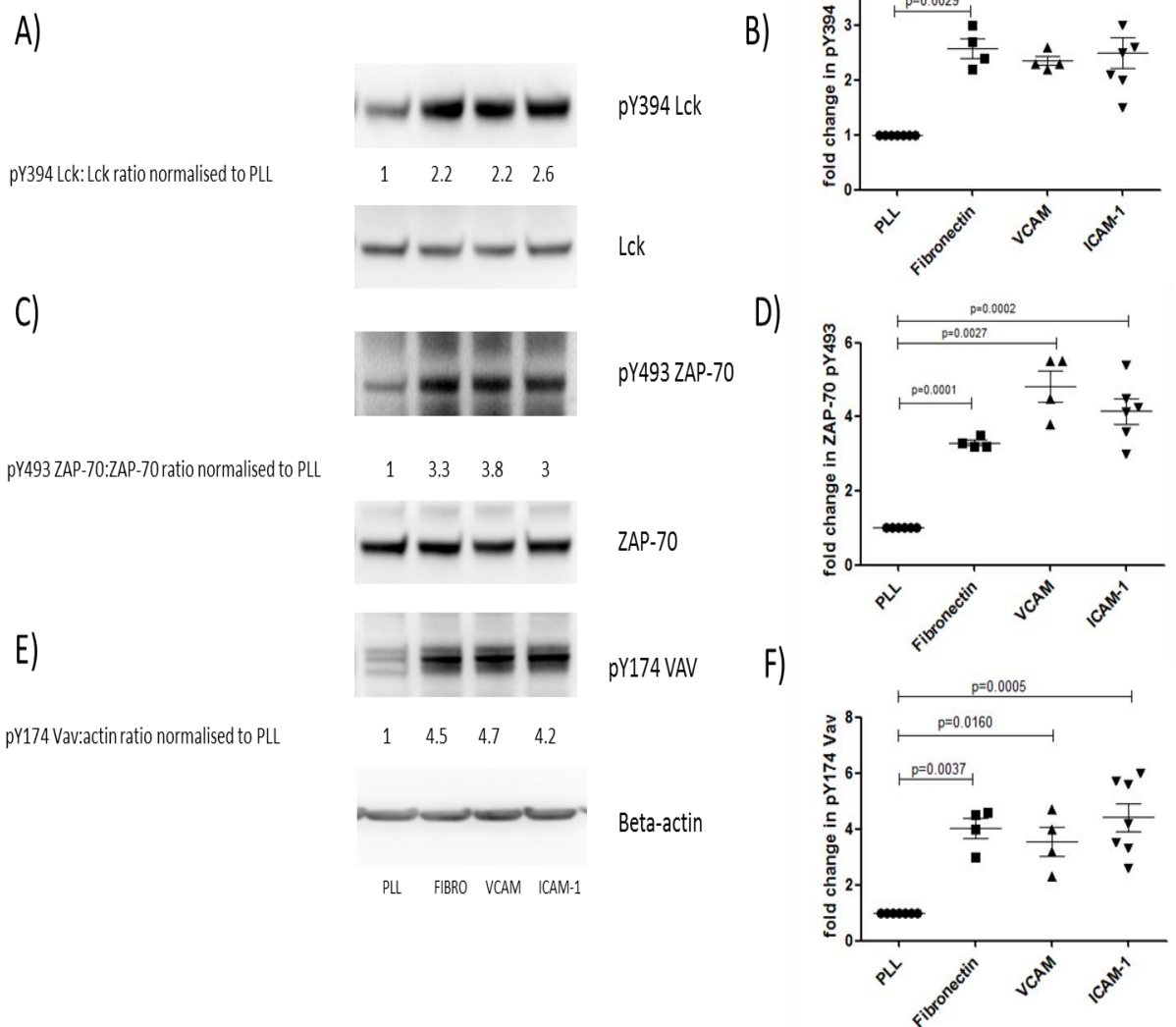

Figure 5.1: Lyp substrates are phosphorylated when integrins engage their counterligand. Plates were coated with integrin ligands fibronectin (10ug/mL) VCAM (3.5ug/mL), ICAM (3.5ug/mL) or PLL as a control (0.01%). T blasts were then plated onto ligands and after 20 minutes excess cells were washed off and platebound cells were lysed. Lysates were resolved on SDS-PAGE gels and phospho-antibodies against Lck (A), ZAP-70 (B) and VAV (D) were used to investigate relative phosphorylation between PLL and ICAM-1 as quantified in B, C and D respectively.

5.3 Signalling is sustained in T cells migrating on fibronectin, VCAM and ICAM-1

The temporal profile of Lyp substrate phosphorylation was next investigated by plating cells for different periods of time and then investigating phosphorylation by western blotting (Figure 5.2). Lyp substrate phosphorylation was detectable for periods of up to 60 mins. These experiments suggested that phosphorylation of Lyp substrates was sustained so long as integrin was engaged with its counter-ligand. To confirm the specificity of signal transduction, ICAM-1 induced phosphorylation of Lck and Vav was tested in the presence of an anti-ICAM-1 antibody that masks the binding site recognised by LFA-1 (the first globular domain within the N-terminus of ICAM-1). These experiments demonstrated that by blocking ICAM-1, the signal was almost completely abolished (Figure 5.3).

Together, these experiments demonstrated that the substrates of Lyp are phosphorylated in response to integrin engagement, and that this phosphorylation was sustained over a long period of time. The sustenance of such a signal might be misleading, and this was probably due to employing western blotting, a technique that can only detect the “average” phosphorylation within a T cell population displaying a certain post translational modification. The signalling is predicted to be dynamic, with increasing or decreasing levels of tyrosine phosphorylation on signalling intermediates like Lck, ZAP-70 and VAV occurring in specific locales within the cell to allow for coordinated locomotion. In this context, Lyp may contribute to the dynamic regulation

of signalling intermediates. The direct association between Lyp and its target substrates in control and stimulated T cells was next evaluated.

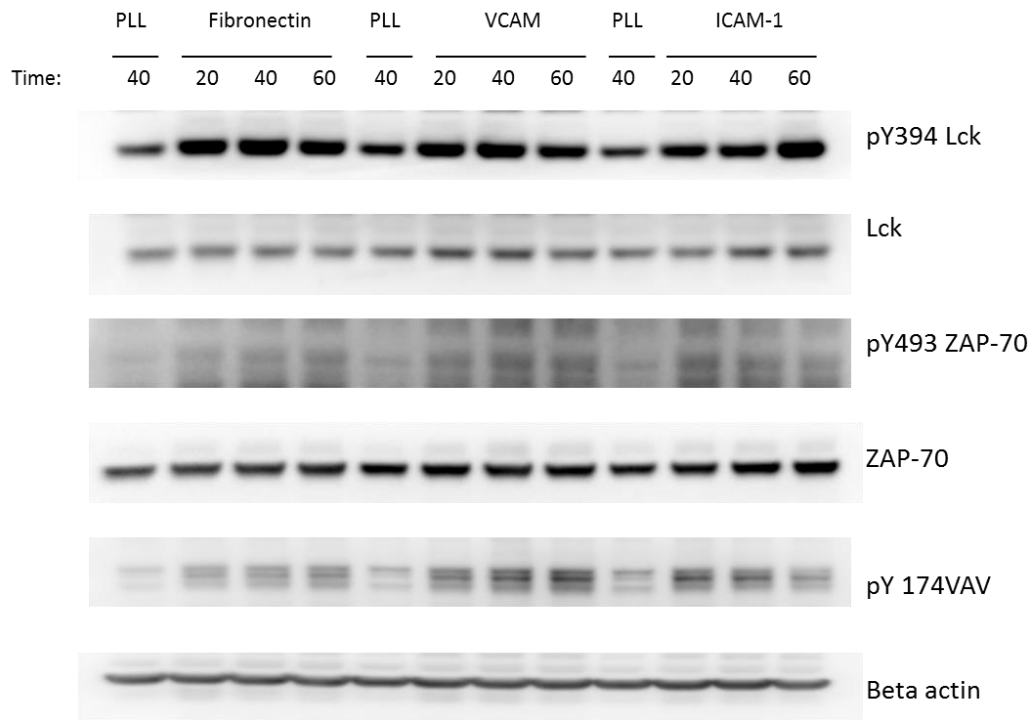

Figure 5.2: Lyp substrates phosphorylation is sustained in migrating T blasts. The experiment was performed as in figure 5.1 only lysates were harvested at 20, 40 and 60 minutes following the plating of cells onto integrin ligands or PLL.

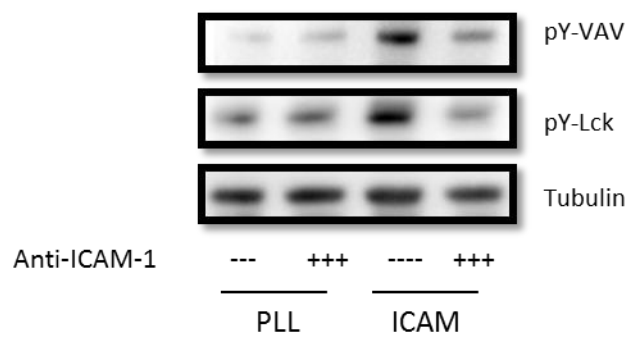

Figure 5.3: Blocking ICAM-1 inhibits LFA-1 signalling. Plates were coated with PLL (0.01%) or ICAM-1 (3.5ug/mL) overnight at 4C, washed once and then incubated with 5ug/mL anti-ICAM-1. Following 3 washes in PBS, cells were then plated for 30mins, lysed and probed for pYLck and pYVav with tubulin as a control.

5.4 Lyp associates with phospho-proteins when T cells migrate on ICAM-1

Many enzymes require that their substrate is appropriately modified in order for interaction to occur (the so called “lock and key” theory). Studies investigating the requirement of Lyp to engage Lck and ZAP-70 clearly demonstrate that interaction is predicated on the phosphorylated motifs that Lyp targets (Clarke 2007). Presumably conformational changes and substrate topology play a role in allowing Lyp to engage substrate, although this has never been directly demonstrated. Given these requirements, an experiment to demonstrate that Lyp was associated with its phospho-substrates was undertaken.

Lyp was immunoprecipitated from cells immobilised on PLL or cells migrating on ICAM-1. The resulting immunoprecipitates were resolved by PAGE and anti-phosphotyrosine specific antibodies used to probe for associated phosphoproteins in immobilised versus migrating cells. Figure 5.4 demonstrates that when T cells migrate on ICAM-1, a strong and inducible signal was observed in the form of a ladder of seven phosphorylated proteins and three fainter bands, providing evidence to suggest that Lyp engages directly (or indirectly) with its substrates in migrating T cells; only one single phosphoprotein of 50kDa was detected in immobilised cells. Of the bands detected, 4 resolved to the size of proteins known to interact with Lyp. These bands resolved at 50kDa, 56kDa, 70kDa and 118kDa, molecular weights very similar to those of Csk, Lck, ZAP-70 and Vav, respectively. Phospho-antibodies that specifically recognise phosphorylated Lck, ZAP-70 and VAV (no pY-Csk antibodies are currently

available) were then employed to confirm the results from the total-phosphotyrosine blots performed on Lyp immunoprecipitates.

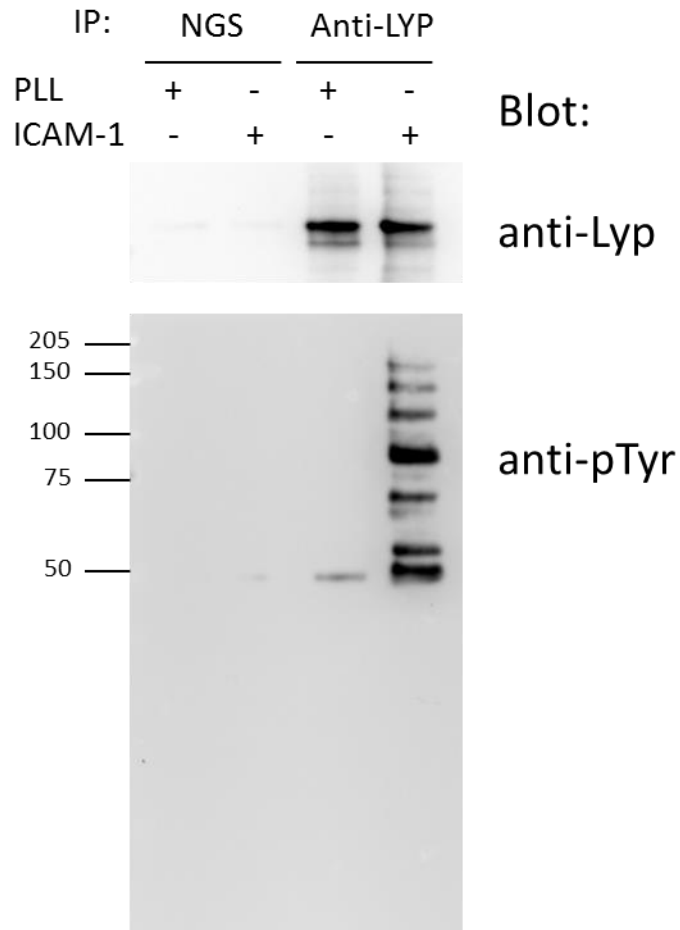

Figure 5.4: Lyp engages phosphorylated proteins when T cells engage migrate on ICAM-1. T blasts (PHA stimulated + IL-2 for 10 days) were plated onto PLL or ICAM-1 and after 30mins cells were lysed on the plate and Lyp was immunoprecipitated. The resulting immunoprecipitate was resolved using SDS-PAGE and an antibody recognising phosphorylated tyrosine motifs was used to detect any tyrosine phosphorylated proteins within the immunoprecipitate. A total anti-Lyp antibody was then used as a control to show equivalent amounts of Lyp had been captured.

5.5 Lyp targets phosphorylated Lck, ZAP-70 and VAV when T cells migrate on ICAM-1

Lyp dephosphorylates proteins at their activatory tyrosine residues. In this context, three signalling scenarios could be envisaged where Lyp may be important. Scenario one might involve Lyp tonically inhibiting signal in resting cells to ensure that basal levels of phospho-tyrosine are held in check in the absence of receptor engagement. Scenario two is that Lyp may be an important regulator of active signalling, insuring that active signals do not overshoot, which may lead to inappropriate responses or cellular pathology. Finally, Lyp may be an important regulator of signal shutdown or termination. Of course, none of these scenarios are mutually exclusive.

Co-immunoprecipitation experiments of Lyp from immobilised T cells versus migrating T cells might give some indication of when Lyp is targeting substrates and therefore an indication of when, during signal transduction, its function is required. When comparing the interaction of Lyp with pYLck, pYZAP-70 and pYVAV in immobilised cells versus migrating cells, Lyp was interacting strongly with its substrates only when T cells were migrating on ICAM-1 (Figure 5.5). At all time points, over the course of 5 experiments, there was a strong association of Lyp and its substrates so long as LFA-1 was engaged, suggesting that Lyp may be actively regulating Lck, ZAP-70 and Vav when signals were being transduced through LFA-1. The fold change in Lyp substrate interaction was much higher than the fold change in phosphorylation on Lyp substrates in the total cell lysates, with an average fold change of 7.7, 10.8 and 9.4 for pY394 Lck, pY493 ZAP-70 and pY175 Vav, respectively.

In immobilised cells, there was detectable signal indicating basal levels of Lyp-substrate interaction in non-signalling cells, but this was modest relative to the signals detected in migrating cells. Importantly, the phosphorylation status of the Lyp substrates appeared to be important for Lyp-substrate interaction as indicated by the highly phosphorylated residues on Lck (pY394), ZAP-70 (pY319 and pY493) and Vav (pY174). This correlated well with total protein, which, in line with previous reports, might suggest that Lyp-substrate interaction can be directly correlated with substrate phosphorylation. These experiments provided direct evidence that the Lyp phosphatase interacts with its phosphorylated substrates, specifically phosphorylated pools of Lck, ZAP-70 and VAV in migrating cells.

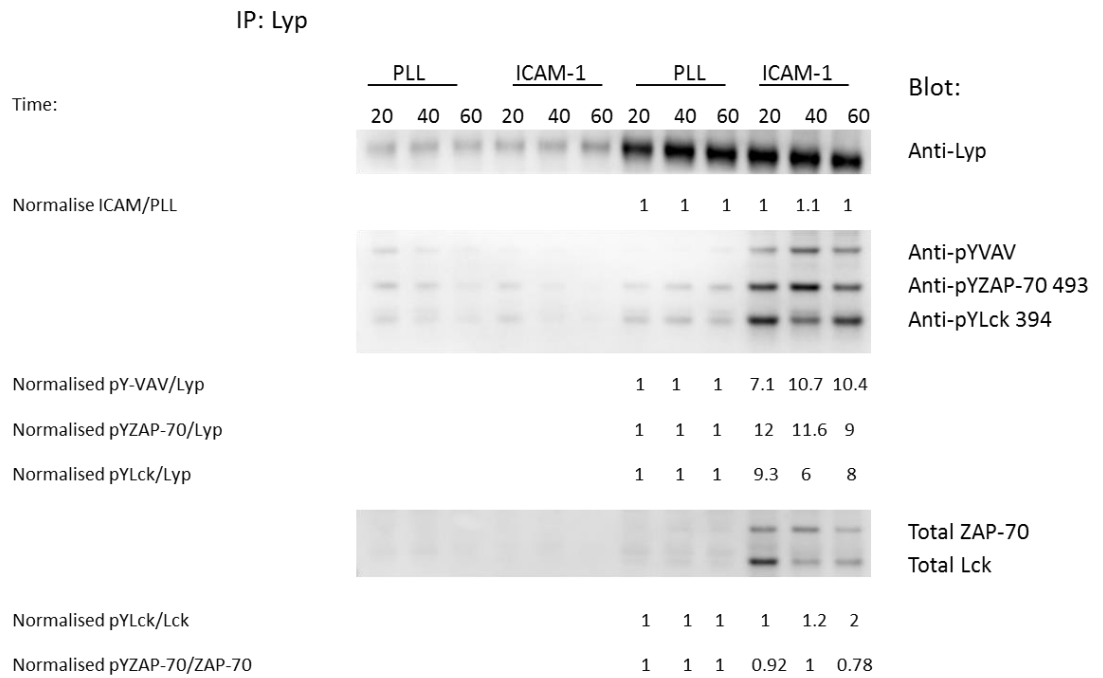

Figure 5.5: Lyp engages Lck, ZAP-70 and Vav when T cells migrate on ICAM-1. T blasts (PHA stimulated + IL-2 10 days) were plated onto PLL or ICAM-1 coated plates, were lysed at 0, 20, 40, 60 minute timepoints and Lyp was immunoprecipitated. Phospho-specific antibodies were then used in combination to probe for pY394 Lck, pY493 ZAP-70 and pY174 Vav. Total Lck and ZAP-70 was then probed for, followed by an anti-Lyp probe to demonstrate equal loading. Quantification was undertaken by densitometry of specific bands and expressed as a ratio of phospho-specific protein to total Lyp protein for each signaling intermediate.

The results were confirmed by performing immunoprecipitations of Lyp substrates and then blotting for Lyp. Analysis of Csk, Lck, ZAP-70 and VAV immunoprecipitates demonstrated increased association with Lyp when T cells migrated on ICAM-1 (Figure 5.6). In contrast, Lyp did not associate with the TCRzeta chain in either non-migrating or migrating T cells. These experiments demonstrate that Lyp actively targets a subset of its substrates when T cells migrate on ICAM-1.

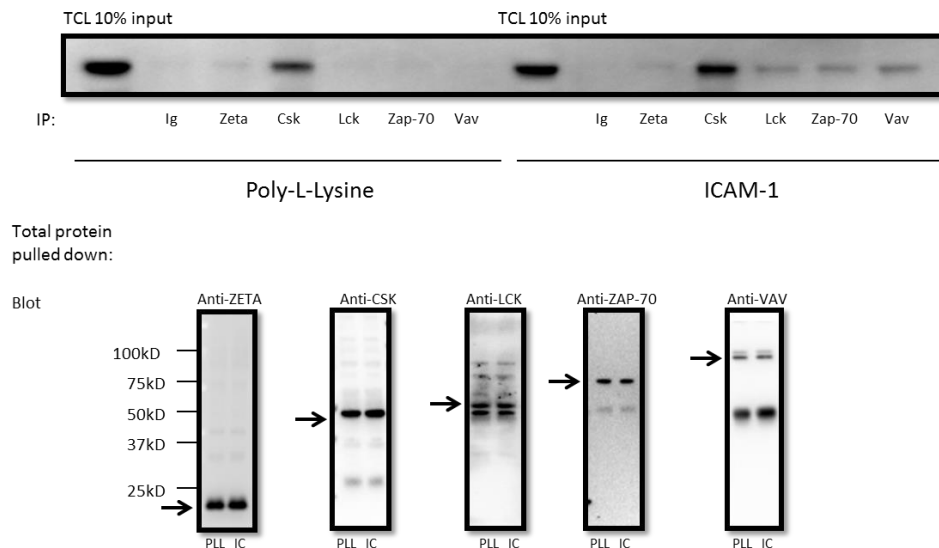

Figure 5.6: Lyp interacts with a subset of its substrates when T cells migrate on ICAM-1. T blasts (PHA stimulated + IL-2 10 days) were plated onto ICAM-1 or PLL for 30 mins, cells were lysed on the plate and Zeta chain, Csk, Lck, ZAP-70 and Vav were then immunoprecipitated and resolved by SDS-PAGE. An anti-Lyp antibody was then used to blot (top panel). Bottom panel demonstrates equal loading of immunoprecipitated proteins. A small aliquot from each immunoprecipitate was run on SDS-PAGE gels and total protein captured was detected using anti-zeta, anti-Csk, anti-Lck, Anti-ZAP-70 and anti-Vav antibodies.

5.6 Stoichiometric changes in the LFA-1/Lck/ZAP-70/Vav complex when T cells migrate on ICAM-1

The dynamic changes in Lyp-substrate interactions when T cells migrate prompted further biochemical analysis of LFA-1 and the association of this integrin with Lyp substrates. Thus, LFA-1 was immunoprecipitated from immobilised and migrating T cells and immunoprecipitates were then subjected to immunoblotting with antibodies directed at Lck, ZAP-70 and VAV.

These experiments indicated that LFA-1 appears to be constitutively associated with Lck, an association that showed a ~4 fold increase when T cells migrated on ICAM-1 when compared to PLL (Figure 5.7). In addition to the recruitment of more Lck to LFA-1 when T cells migrate, these experiments demonstrated that ZAP-70 was also recruited and was heavily phosphorylated on the pY493 residue, with ~7 fold increase in signal over that documented for cells immobilised on PLL. Thus, it appears as though the association of these signalling intermediates with LFA-1 correlated with their phosphorylation status.

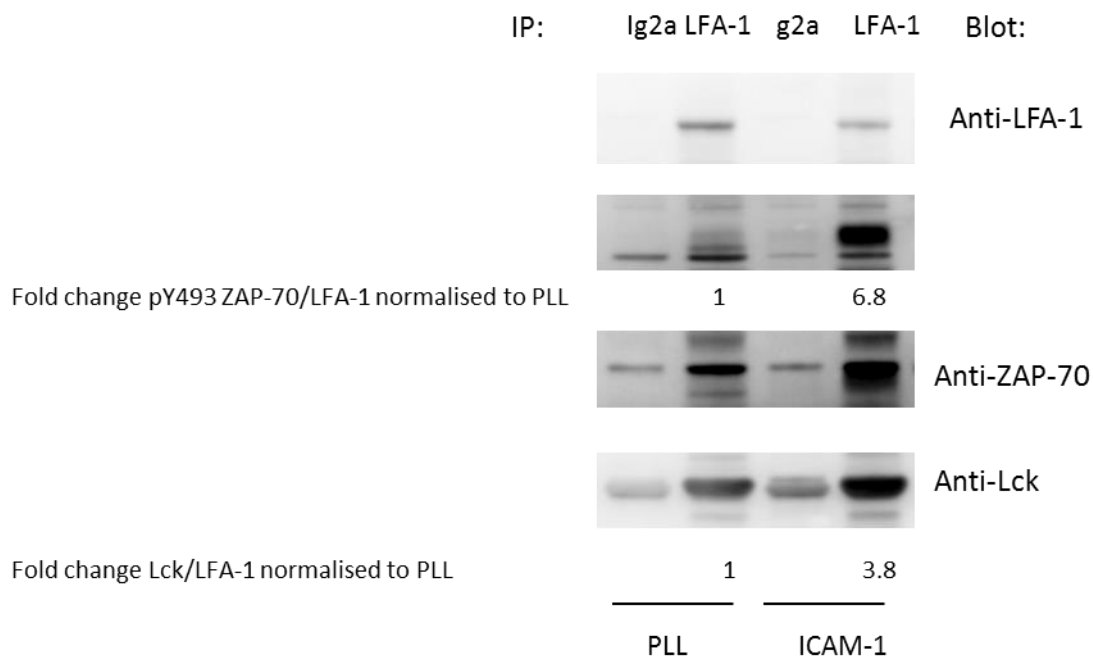

Figure 5.7: ZAP-70 and Lck associate with LFA-1 when T cells migrate on ICAM-1. T blasts (PHA stimulated +IL-2 10 days) were plated on PLL or ICAM-1 for 30 mins, lysed using Triton x-100, and LFA-1 was immunoprecipitated. The immunoprecipitate was resolved by SDS-PAGE and the membranes were probed with anti-pY493 ZAP-70 followed by total Zap-70 and total Lck. LFA-1 was blotted for to ensure comparable protein capture.

Similar experiments were then undertaken to explore the association of Vav with LFA-1 in migrating cells. In contrast to Lck and ZAP-70 being recruited, Vav on the other hand dissociated from LFA-1, as indicated by a reduction in band intensity of 87%. This suggests that active integrin signalling is associated with dissociation of Vav from the LFA-1 signalling complex (Figure 5.8). Consistent with this finding were the results of immunoblotting with a phospho-specific antibody recognising pY174 on Vav, demonstrating a clear decrease in phospho-Vav signal in the LFA-1 complex when T cells migrate. Vav undergoes a shift in mobility from 90kDa to 118kDa when phosphorylated at pY174 and so it was possible to determine the total pools and the phosphorylated pools using the total antibody, although the total antibody was nowhere near as sensitive at picking up phospho-Vav when compared to the phospho-antibody.

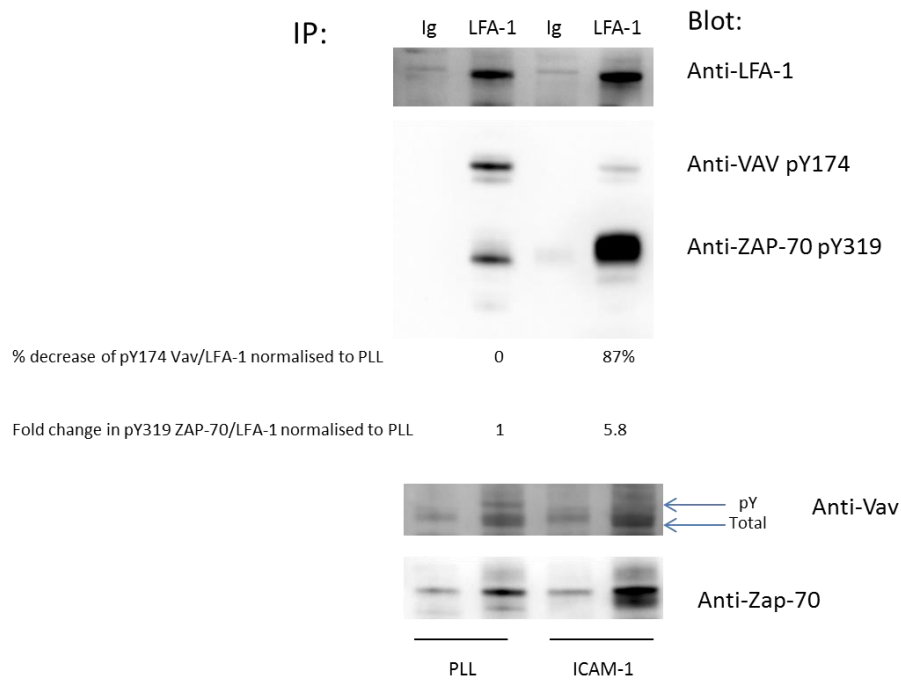

Figure 5.8: Vav dissociates from LFA-1 when T cells migrate on ICAM-1. T blasts (PHA stimulated+IL-2 10 days) were plated onto PLL or ICAM-1 for 30 mins, cells lysed and LFA-1 was immunoprecipitated. The precipitates were run on SDS-PAGE gels and probed with anti-pY174Vav and anti-pY319 ZAP-70 followed by total ZAP-70 and Vav antibodies. Finally, total LFA-1 was probed for to ensure equal protein capture.

These experiments revealed that whilst a small amount of unphosphorylated Vav was associated with LFA-1 (at levels detected only just above that of isotype control antibody), there were no changes in the stoichiometry between these pools and LFA-1. Instead, an already phosphorylated species of Vav was highly associated with LFA-1 in cells immobilised on PLL, and this pool appeared to dissociate when T cells migrated. As a control, pY319 ZAP-70 was blotted for simultaneously and the dynamics of LFA-1 association were found to occur in the complete opposite direction. Thus, Lck and ZAP-70 appear to associate with LFA-1 in migrating cells, and this event was found to be associated with the release of a phosphorylated Vav from an actively signalling LFA-1 complex.

5.7 Lyp and Csk associate with LFA-1 when T cells migrate on ICAM-1

To understand whether or not Lyp and Csk formed a part of the LFA-1 signalling complex in migrating cells, LFA-1 immunoprecipitates were analysed for Lyp and Csk expression (Figure 5.9). Under PLL conditions, there was some association of Lyp and Csk with LFA-1 while Lyp and Csk displayed increased association with LFA-1 in migrating cells, with a 2.8 and 2.5 fold increase respectively, when compared to PLL.

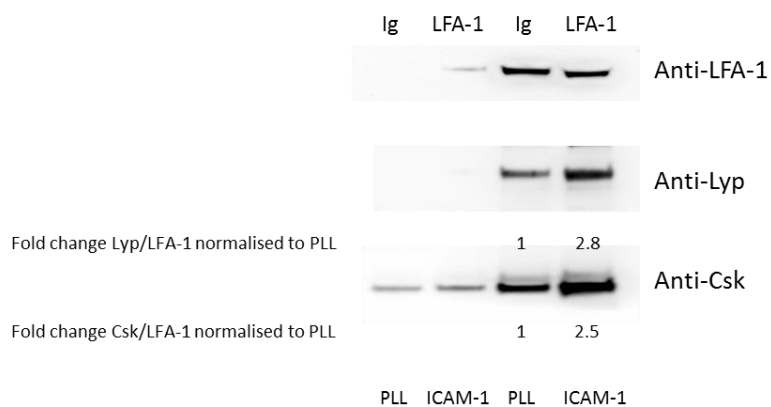

Figure 5.9: Csk and Lyp are recruited to LFA-1 when T cells migrate on ICAM-1. T blasts (PHA stimulated+IL-2 10 days) were plated on PLL or ICAM-1 for 30 mins, cells were lysed and LFA-1 was immunoprecipitated. Immunoprecipitates were resolved by SDS-PAGE and Csk and Lyp were probed for. LFA-1 was then probed for to ensure equal loading of protein.

The recruitment of these signalling intermediates that negatively regulate the pathway might represent an important mechanism by which dynamic phosphorylation at the receptor level is regulated. Given the average phospho-intensities demonstrated on blots due to population dynamics, a situation where many different permutations of kinases and phosphatases making up a mature signalling complex can be envisaged, some of which are actively being negatively regulated by phosphatases, whilst other signalling complexes might contain mainly active kinases that propagate and maintain signals in a region specific manner.

5.8 LFA-1 and Lyp co-localise in migrating T cells

LFA-1 staining patterns were compared with Lyp staining patterns in migrating T cells by confocal microscopy. LFA-1 showed a punctate staining that was relatively homogenously distributed around the cell, consistent with the idea that LFA-1 is highly expressed, is located at the cell membrane and is regulated through conformational changes rather than large changes in protein redistribution. LFA-1 and Lyp co-localised at the leading and lagging edge of T cells. These data indicated that Lyp may be specifically regulating signal transduction events initiated by LFA-1 at the leading and lagging edge of the cell.

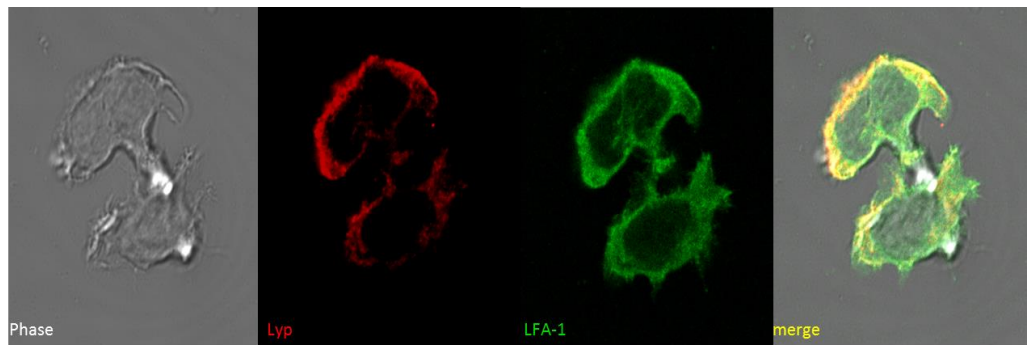

Figure 5.10: LFA-1 and Lyp co-localise in migrating T cells. T blasts were plated onto ICAM-1, fixed and stained with anti-Lyp and anti-LFA-1. Images were acquired by Dr Lena Svensson.

5.9 Lyp co-localises with Csk, Lck, ZAP-70 and VAV in migrating T cells.

Given that Lyp co-immunoprecipitates with Lck, ZAP-70 and Vav when T cells migrate on ICAM-1 it became important to understand where these interactions might be occurring (Figure 5.11a). Using total antibodies, Lck, ZAP-70 and Vav expression was found to be distributed throughout the cell with some evidence of accumulation at the leading and lagging edge, where co-localisation with Lyp was clearly evident, suggesting that their regulation by Lyp might be confined to specific regions of the cell, mainly at the back and the front of the cell.

Next, phospho-antibodies were used to understand where the active pools of phosphorylated Lck, ZAP-70 and Vav were located in migrating cells. Interestingly, the phosphorylated species of these signalling intermediates were also confined to the leading and lagging edge of migrating T cells, where they could be found co-localised with Lyp (Figure 5.11B).

Taken together with the biochemical data demonstrating interactions between Lyp and the substrates investigated by immunofluorescence here, it appeared as though activated pools of Lyp substrate, as demonstrated by phospho-specific antibodies, were localised to the leading and lagging edge of migrating T cells, in areas where Lyp localised, suggesting that Lyp was actively regulating the phosphorylated substrates at the leading and lagging edge of migrating T cells.

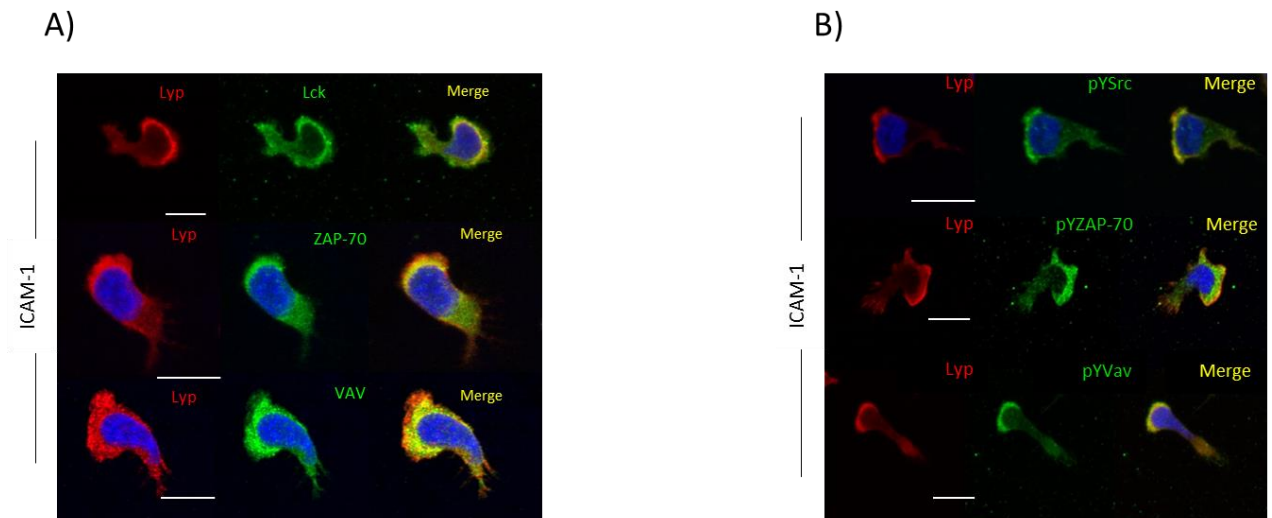

Figure 5.11 Lyp co-localises with Lck, ZAP-70 and Vav when T cells migrate on ICAM-1.

T blasts (PHA stimulated+IL-2 10 days) were plated onto ICAM-1 and after 30 mins were fixed, permeabilised and stained with an anti-Lyp antibody in combination with either total Lck, ZAP-70 or Vav (A) or with anti-Lyp in combination with phospho-antibodies directed at pY419 src, pY493 ZAP-70 and pY Vav. Images were acquired by scanning confocal microscope. Scalebar=10 μ m

5.10 The R620W SNP leads to increased phospho-ERK1/2 activity when LFA-1 binds ICAM

To better understand the effect of the binding mutation in Lyp on integrin signalling, studies were undertaken using RR620, RW620 and WW620 variants in genotyped individuals, which represented individuals who did not have the SNP (RR), who were positive for one copy (RW) or were homozygous for the SNP (WW). I chose to use ERK phosphorylation as a read-out for integrin signalling because I reasoned that a downstream readout of integrin engagement will more likely demonstrate differences due to the amplification cascades associated with signalling. Small upstream receptor proximal signalling events are measurable by western blot, but I reasoned that any small upstream changes might be amplified downstream of the signalling pathway. These experiments demonstrated that individuals who carry one or more disease associated allele show increased ERK phosphorylation in a dose dependent manner. Thus individual's heterozygous still showed significant increases in ERK phosphorylation as compared to individuals who were negative for the disease associated allele, but homozygous individuals showed an even more significant increase in ERK phosphorylation (Fig 5.12 A+B). To understand the consequence of a loss of the PTPN22 locus, ERK phosphorylation was monitored in mouse T cells that were deficient for PEP and was compared to WT mouse T cells. The PEP knockout mice were found to exhibit increases in ERK phosphorylation, essentially phenocopying the human mutation (Fig 5.12 C+D). These results strongly suggested that the human SNP associated with autoimmune disease was loss of function.

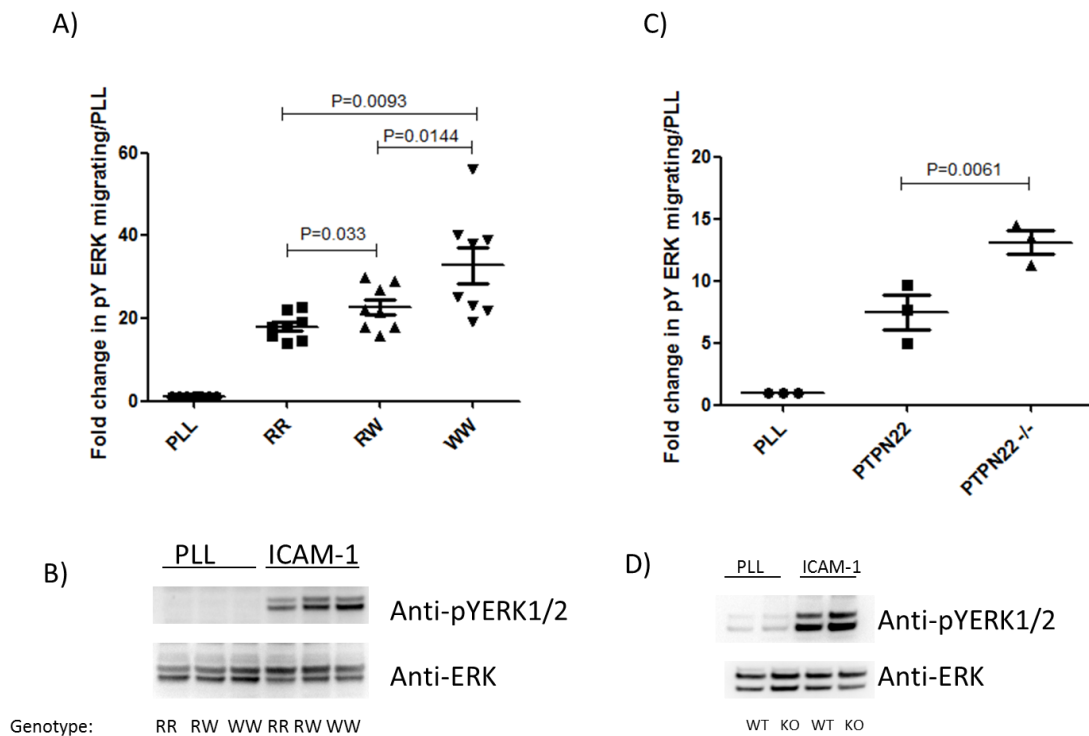

Figure 5.12 ERK phosphorylation is increased in the context of the W620 mutation

and in PEP knockout T cells following integrin engagement. A+B) Human T cells (PHA stimulated+IL2 5 days) from genotyped individuals were plated onto ICAM-1 or PLL for 20 mins and ERK phosphorylation was monitored by Western Blot and C+D) WT (PTPn22) and PEP knockout (PTPn22^{-/-}) mouse T cells were stimulated (ConA+IL2 5 days) and plated onto ICAM-1 or PLL for 20 mins and ERK phosphorylation was monitored by Western Blot. Representative of 8 experiments (Human) and 3 experiments (Mouse).

Discussion

The way in which information is transduced through an integrin when counter-ligand is engaged is an emerging field. How integrin function is regulated via conformational changes when receptors on the surface of T cells are engaged remains at the forefront of investigation. Examples of receptors that, when engaged, lead to changes in LFA-1 conformation on T cells include the selectins, chemokine receptors and the T cell antigen receptor (Hogg, Harvey et al. 1993, Dustin, Bromley et al. 1997, Shamri, Grabovsky et al. 2005, Luo, Carman et al. 2007). The changes in LFA-1 conformation expose binding sites on the integrin which in turn allow for interaction with counter-ligands such as ICAM-1. Once counter-ligand is engaged, a signal is transduced through the integrin itself leading to fundamental changes in cell polarisation and the activation of migration machinery (Dib 2000, Evans, Lellouch et al. 2011, Hogg, Patzak et al. 2011, Cimo, Ahmed et al. 2013).

The use of Src and Syk family kinase members by integrins as proximal signalling intermediates that bind to the integrin cytoplasmic tails has been known for some time (Hynes 2002). Integrins are very complex proteins that are involved in diverse cellular functions. Studying the diverse function of integrins has been difficult due to the largely redundant functions within the integrin sub-families. An important aspect of integrin signalling biology is that of context. No single receptor on the cell surface will be exclusively engaged, and in the case of integrins, the co-engagement of other receptors may be very important in terms of the cellular outcome. Defining how these associated pathways contribute to the regulation of signalling by integrins, not only with respect to the physical changes in integrin conformation but also the type of

signal that may be transduced when integrin is co-engaged with another receptor, remains a formidable challenge (Munger and Sheppard 2011). Conversely, how integrin engagement alters cellular programming and transmits environmental cues inside the cell remains virtually unknown, at least in terms of the biophysical events leading up to integrin being able to associate with signalling intermediates. To complicate matters further, it is clear that the same integrin expressed by different cell types utilises different signalling machinery (Abram and Lowell 2007). My investigations have focused only on migration, but the possibility that other integrin-mediated cellular responses are also regulated by Lyp remains a distinct and very real possibility, and worthy of further investigation.

In the studies described in this chapter I adopted a reductionist approach, using a more physiologically relevant experimental system to induce a signal than that of antibody crosslinking of integrin on the cell surface. Purified integrin ligands were coated to a 2D surface over which T cells could migrate. This approach facilitated an interrogation of signalling dynamics that might more faithfully recreate integrin signalling *in vitro* when compared to that of the more “sledge hammer” crosslinking approach.

Given that Lyp had previously been shown to interact with Lck, ZAP-70 and Vav in substrate trap experiments (Wu, Katrekar et al. 2006), it seemed a logical first step to explore the phosphorylation of these signalling intermediates downstream of integrin ligation to see how phosphorylation of Lyp substrates are regulated in the context of this *in vitro* model of migrating human T cell blasts.

My experiments demonstrated that Lck, ZAP-70 and Vav were phosphorylated on residues associated with activation. The phosphorylation of these signalling

intermediates was independent of the integrin ligand used and suggested that a common core signalling module existed for a range of different integrins tested. One question that arises from these findings is how, if the signalling module appears to be essentially identical, can cells discriminate between different integrins being engaged? Moreover, other receptors, including chemokine receptors, interferon receptors and the antigen receptor in T cells have been shown to utilise a similar core module in response to receptor engagement (Petricoin, Ito et al. 1997, Micouin, Wietzerbin et al. 2000, Ticchioni, Charvet et al. 2002, Kremer, Humphreys et al. 2003, Ahmed, Beeton et al. 2005, Kumar, Humphreys et al. 2006, Stevens, Simeone et al. 2010). The utilisation of the same signalling intermediates in completely different pathways remains enigmatic, although not completely inexplicable, and I predict that post translational modifications, spatial arrangement and signal kinetics could play a key role in instructing the cell as to what kind of receptors are being engaged. In addition, there may be other, integrin-specific signalling intermediates, confined to certain signalling pathways, that confer specificity of cellular responses.

One particularly interesting aspect of the integrin signalling studies was that of the signal kinetic observed. Western blotting analysis indicated that phosphorylation of Lck, ZAP-70 and VAV was sustained in migrating cells over time. Western blotting, by its very nature, describes biochemical changes at a population level, and does not give information regarding individual cells, or indeed, the signalling events in sub-cellular compartments within individual cells. Given the highly dynamic nature of cell migration, it is tempting to speculate that whilst there are net changes in phosphorylation of signalling intermediates, the overall signal will be dynamic, with increases and decreases of phosphorylation within specific regions of cells that in turn

govern processes like membrane protrusion or contraction in response to cytoskeletal rearrangement downstream of integrin engagement.

Lyp substrates are phosphorylated in response to integrin ligands, and the specificity of this response was also confirmed by blocking signalling in T cells migrating on ICAM-1 with anti-ICAM-1 antibodies (Fig 5.3). To document the physical interactions between Lyp and its substrates Lck, ZAP-70 and Vav, co-immunoprecipitation experiments were carried out. In migrating cells, Lyp could be found to be associated with its substrates to a much greater extent than that observed in non-migrating T cells. This finding indicated that Lyp was actively targeting its substrate under migratory conditions, and providing the physical association required to mediate regulation of migration via its catalytic domain (Chapter 4). Confocal studies, shown in Figure 5.11 were certainly in keeping with these findings. In non-migrating cells, very little Lyp was associated with Lck and ZAP-70 with almost no signal from Vav, a component of the signalling pathway that we predict to be downstream of Lck and/or ZAP-70. Thus, whilst we cannot exclude that Lyp plays an important role in tonically regulating activatory signals, the stoichiometric changes in Lyp-substrate interactions in migrating T cells suggested that Lyp was targeting and presumably dephosphorylating its substrates in migrating cells. This targeting of signalling intermediates during an active signal would be in keeping with the requirement of dynamic phosphorylation to drive coordinated cell migration. Finally, to understand the relationship between Lyp, its substrates and LFA-1, additional co-immunoprecipitation experiments were performed. These experiments demonstrated Lck and ZAP-70 could be found readily associated with LFA-1 when T cells migrate, while Vav dissociated, as compared to non-migrating T cells. The association of Lck and ZAP-70 with LFA-1 was, to our surprise, correlated with Lyp and

Csk recruitment to LFA-1. The dissociation of Vav was inversely correlated with Lyp and Csk recruitment to LFA-1. Thus, a picture starts to emerge wherein Lyp and Csk may be actively regulating signalling activity through interaction (directly or indirectly) with integrin cytoplasmic tails. It was noted from analysis of LFA-1 immunoprecipitates, all LFA-1, regardless of conformation and signalling intermediate composition, immunoprecipitated. This does not mean I immunoprecipitated all LFA-1 but rather that the pool of LFA-1 that I pulled down from was made up of various LFA-1 conformations.

The actual make-up of the individual signalling platforms associated with individual LFA-1 molecules in a spatially defined manner was lost. Thus it is possible that some LFA-1 molecules may have intermediates like ZAP-70 and Lck exclusively associated with it. It follows that many permutations of Lck, ZAP-70, Lyp and Csk may exist at the cytoplasmic tails of LFA-1, but the resolution of the method employed in this investigation does not allow for the monitoring of individual signalling complexes.

Antibodies directed at specific LFA-1 epitopes that become exposed as conformational changes occur could be of great value to try and understand the relationship between the conformations of LFA-1 and the associated signalling complexes that arise from conformational changes (low to intermediate to high avidity) which have been reported to occur in response to integrin ligation and have been postulated to drive signal transduction (Landis, Bennett et al. 1993, Stephens, Romer et al. 1995).

The dissociation of Vav from LFA-1 on the other hand, might suggest that Lyp regulates Vav in a different cellular compartment, especially in light of the fact that Lyp is

targeting Vav as demonstrated by co-immunoprecipitation experiments. These results raise the interesting possibility that Lyp is regulating multiple nodes of the signal transduced via LFA-1, both at the integrin tails themselves and within another cellular compartment containing Vav.

Together, these results strongly suggest that Lyp was targeting phosphorylated Lck, ZAP-70 and Vav in actively migrating T cells, and that Lyp could target substrates associated with LFA-1 or not associated with LFA-1.

Finally, I was able to demonstrate that ERK phosphorylation was increased in human individuals harbouring the disease associated SNP and that this increase in ERK phosphorylation was mirrored in the mouse PEP knockout cells, indicating that the human mutation may be a loss-of-function. ERK has previously been shown to be activated in response to integrin ligation, and that its activation in T cells is Lck dependent (Cimo, Ahmed et al. 2013). In contrast, ERK activation is highly dependent on ZAP-70 phosphorylation when TCR is engaged. Perhaps the differential activation of ERK by integrin versus TCR might then lead to a specific ERK induced cell programme consistent with the receptor requirements. I chose to investigate ERK because I reasoned that because of the way signal amplification tends to work, small upstream changes can lead to large changes in downstream effectors. ERK has also previously been shown to be an important regulator of cell migration (Roskoski 2012). In healthy T cells, the consequence of ERK activation through integrins has not been studied, however, there appears to be a prominent role of ERK activation and T cell migration in malignancy (Naci and Aoudjit 2014). Experiments leading to the understanding of how ERK contributes to T cell migration in healthy cells are required but will most likely yield very interesting results.

Chapter 6
Nanoscale organisation of Lyp

Super-resolution imaging of Lyp

To date, no data exist in the literature describing the nanoscale organisation of intracellular protein tyrosine phosphatases. Utilising Total Internal Reflection Microscopy, coupled with Stochastic Optical Reconstruction Microscopy (TIRF-STORM), the nanoscale organisation of Lyp proximal to the cell membrane was investigated in T cells migrating on ICAM-1, and compared with T cells immobilised on PLL. The resolution of the images acquired adopting this technique far exceeds that of conventional microscopy (~200nm) by surpassing the diffraction limit, thus allowing the localisation of individual molecules within 15-25nm of one another.

Diffraction limited microscopy produces images of a distribution of fluorophores that excite and emit simultaneously. Such an approach limits the resolution of the image because the overlapping point spread functions of individual fluorophores make it impossible to accurately determine with high precision the location of molecules within ~200nm of each other, even when using TIRF microscopy which illuminates the sample in one plain (Axelrod 1981). The exact resolution in a system that relies on diffraction-limited imaging depends on the wavelength (λ) of light and the numerical aperture (NA) of the microscope lens. These are related by equation 1:

$$\mathcal{R} = \frac{0.61\lambda}{NA}$$

For typical values of wavelength (488 nm) and NA (1.45), this gives a resolution of 205 nm. Super-resolution techniques that break this diffraction limit can be achieved in several ways (Habuchi 2014). Here, single molecule imaging was achieved via STORM, a

technique that takes advantage of the ability to collect information pertaining to the positioning of individual fluorophores by temporally separating the fluorophore's emission from that of its neighbours (Rust, Bates et al. 2006, Heilemann, van de Linde et al. 2008). The stochastic activation of a sparse subset of fluorophores allows for the identification of non-overlapping point spread functions. Two-dimensional Gaussian fitting can then be used to find the centre of each emission, which equates to the X and Y coordinate of the emitting fluorophore. The stochastic emission of fluorophores is achieved by ensuring that at any given time most molecules cannot emit light, and by taking advantage of long lived, non-emitting molecular triplet states, in this case of alexa647. This small organic dye has chemical properties that, when imaged in the presence of an oxygen scavenging buffer, prolongs the triplet or "dark" state by forming a thiol adduct that can be unformed using the same excitation beam. It follows that this fluorophore can excite and stay in the triplet state for a prolonged time before returning to the ground state. This cycle leads to the characteristic blinking of individual fluorophores over time. The X and Y coordinate list that results from centroiding imaged PSFs from each stochastically activated fluorophore produces an unconventional image based on spatial point patterns rather than pixel values that represent the number of detected photons in any given sample region. STORM data can therefore best be described as a spatial point pattern dataset, and as such requires a different statistical analytical approach to understand the relationship between individual localisations, as compared to conventional microscopy.

To analyse spatial point patterns, we collaborated with Dr Dylan Owen, who has tailored an already existing algorithm to analyse sets of molecular coordinates that lack homogeneity, a phenomenon termed "clustering" (Ripley 1977, Ripley 1979, Perry

2004). This was attractive and potentially highly relevant to my work since I reasoned that signalling molecules might operate dynamically, in spatiotemporal terms, through mechanisms involving clustering and de-clustering. The algorithm, put simply, relies on the drawing of a fixed size perimeter around a given molecular coordinate in which the surrounding molecules are counted and scored. Individual molecular scores for molecules within a specific region can then be interpolated to represent the spatial heterogeneity in the form of a coloured pseudomap. Many parameters like the percent of molecules found in clusters, the number of molecules per cluster, cluster diameters and molecule counts can also be derived from the analysis to better understand how molecules are behaving under different conditions – in this case integrin-dependent migration. In addition, Ripley's K-function was used to plot curves describing the clustering of molecules over increasing areas. This analysis is less biased, since a preselected radius used to score molecules in the algorithm might over or underestimate clustering by using a fixed spatial scale during the analysis.

The experiments outlined below describe for the first time the dynamics of clustering of PTPN22/Lyp during cell migration in response to integrin signalling in primary human T cell blasts.

6.1 Lyp de-clusters upon engagement of LFA-1 in migrating T blasts.

A biochemical dissection of Lyp as an integrin signalling intermediate, described in previous chapters of this thesis, suggested that when human T cells migrate, Lyp can

more readily target phosphorylated substrates such as Lck, ZAP-70 and Vav. It was therefore of particular interest to understand whether or not there were any spatial changes in terms of the way in which the phosphatase was organised that might facilitate substrate regulation. There are currently no identifiable reports of single molecule mapping of an intracellular protein tyrosine phosphatase. On the other hand, kinases have been demonstrated repeatedly to cluster upon activation through surface receptors that, when engaged, favour kinase post-translational modification or re-localisation. The prediction, therefore, is that clustering is an activatory event, allowing signalling intermediates to interact in sub-cellular signalling hubs. My hypothesis was that Lyp would also cluster when actively targeting its substrates.

Whole cell images of cells immobilised on PLL or migrating on ICAM-1 suggested that Lyp was highly clustered when T cells were not signalling through LFA-1 (fig 6.1). The clusters in the PLL condition appeared larger than those seen when T cell migrated on ICAM-1. Upon engagement of LFA-1 by ICAM-1, the large clusters appeared to form smaller clusters with Lyp localisation being much more diffuse. It was clear that Lyp, in contradiction to my working hypothesis, was de-clustering at the membrane in response to LFA-1 engagement.

Application of the clustering algorithm permitted more detailed, quantitative analysis of clusters. Figure 6.2 illustrates representative heat maps of clustering in the front regions of a cell corresponding to the lamellipodium. In cells immobilised on PLL, Lyp was highly clustered. Upon LFA-1 engagement of ICAM-1, these large and dense clusters appeared to disperse into smaller clusters. Ripley's K-function, was then plotted, comparing Lyp organisation under PLL conditions with ICAM-1. The analysis clearly demonstrated that Lyp was indeed de-clustering in response to LFA-1

engagement. Taken with the biochemical results, this dataset suggested that Lyp declusters when T cells migrate on ICAM-1 and that this de-clustering event is temporally associated with substrate interaction. To further explore these large clusters, the cluster maps generated through analysis of specific cell regions were examined more closely.

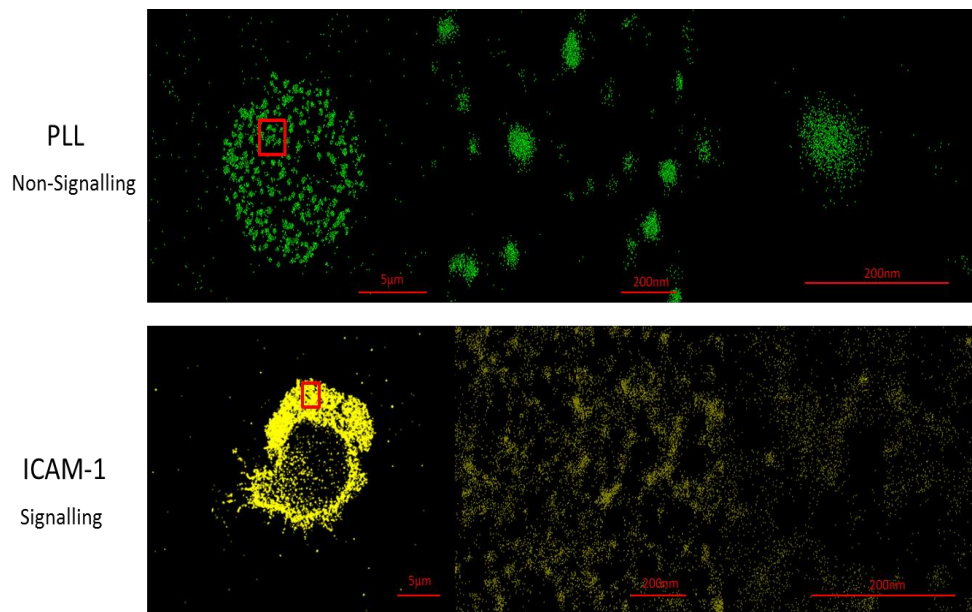

Figure 6.1: Stochastic Optical Reconstruction Imaging (STORM) reveals differences in the nanoscale organisation of Lyp in migrating T cells. Primary T cells were plated onto PLL or ICAM-1, fixed after 20 minutes, stained with mouse anti-Lyp or goat anti-Lyp and then incubated with an anti-mouse secondary conjugated to AF647 and imaged in an oxygen scavenging buffer. Images acquired by TIRF-STORM. Here, the mouse anti-Lyp antibody staining patterns are demonstrated.

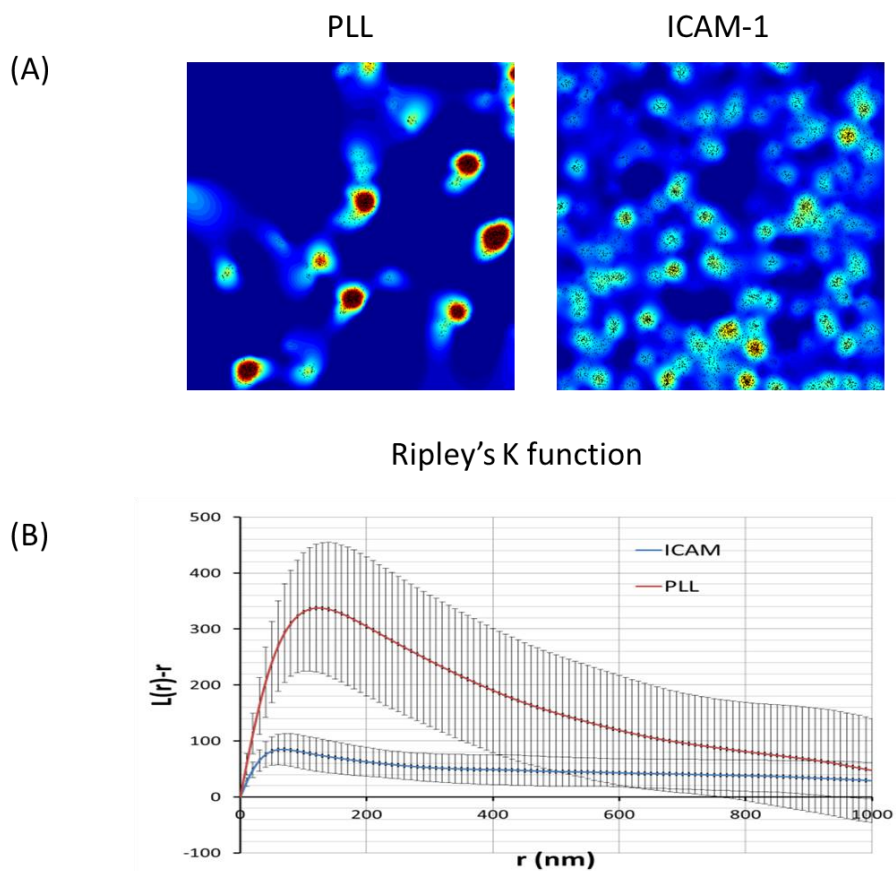

Figure 6.2: Lyp appears to de-cluster when T cells migrate on ICAM-1.

(A) Heat maps of $2 \times 2 \mu\text{m}$ regions demonstrating Lyp clustering at the leading edge of migrating cells (ICAM-1) or on PLL

(B) Ripley's K Function demonstrates that Lyp is more clustered on ICAM-1. Ripley's K function was calculated using at least 25 regions per cell corresponding to the leading edge. Total of 10 cells imaged. Representative of at least 5 experiments

6.2 The dynamics of Lyp declustering at the membrane.

One important question about the clusters observed in the PLL conditions was whether they were actually breaking up when T cells were signalling through LFA-1. This question is of particular interest because there are currently no reports of such an event occurring downstream of receptor engagement in the cytoplasm specifically for phosphatases. The possibility that the large clusters of Lyp may be vesicular in nature might also explain how compartmentalisation allows for efficient and rapid release of molecules in a given region containing substrates that require regulation without the need for mobilisation from one cellular compartment to another. One other membrane embedded phosphatase, CD45, has been reported to be negatively regulated through homotypic dimerisation, although others have contested through the crystallization of CD45 that the occlusion of the catalytic pocket via dimerisation is “impossible” due to the molecular arrangement when homotypic interaction occurs (Majeti, Bilwes et al. 1998, Majeti, Xu et al. 2000). Thus, an open question is “do phosphatases, as opposed to kinases, de-cluster in response to receptor ligation”?

Figure 6.3 depicts a cross-section of cluster maps at the cell membrane in which it appears that the de-clustering of Lyp may have been captured. The top panel shows typical examples of cluster maps of Lyp on PLL, demonstrating large and dense clusters. The bottom panel, on the other hand, shows what appear to be molecules dispersing out from a central point in a spreading-like fashion, despite these cells also being immobilised on PLL. This dispersion was rare, occurring in 3% of all PLL regions. Strikingly, this process of dispersion of Lyp molecules from a single cluster was not

obviously predictive of other surrounding clusters breaking up, suggesting that if it is true that the large clusters are breaking up, the regulation of this process may be intrinsic to the cluster. In other words, if one cluster breaks up, the surrounding cluster need not follow suit.

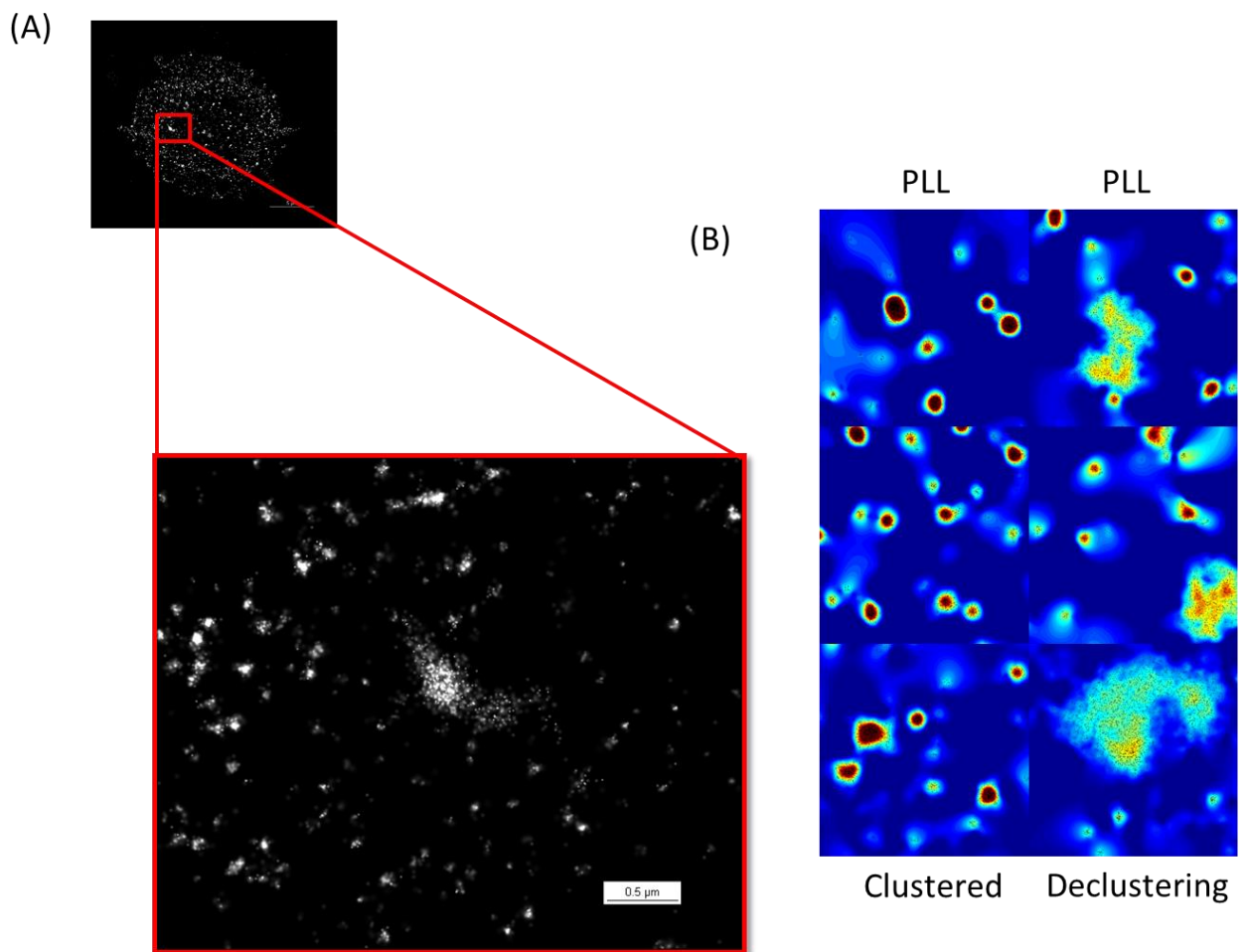

Figure 6.3: Patterns of Lyp clustering and declustering in immobilised (PLL) T cells.

(A) An anti-Lyp stain on resting T cells demonstrating what appears to be de-clustering in a specific region

(B) Heatmaps of Lyp in resting cells demonstrating de-clustering

Such an observation might suggest that a biological process such as calcium mobilisation, which is known to regulate vesicular processes, may not necessarily drive this particular process (Wickner and Schekman 2008). The idea that Lyp may be bound within vesicles, and that vesicle fusion with the plasma membrane is often driven by calcium dependent processes, prompted an experiment where a calcium flux was artificially induced via ionomycin. Under conditions of calcium mobilisation, no de-clustering was observed (Fig. 6.4). One prediction from this result is that because Lyp is an intracellular phosphatase, membrane fusion may not be required, and so perhaps a completely novel and hitherto undiscovered mechanism, involving the intracellular “dumping” of membrane bound vesicles independent of the plasma membrane itself. An alternative explanation is that Lyp is interacting homotypically or associated with scaffolding proteins, and a signal leads to it exiting of Lyp molecules from the cluster. Three dimensional constructs of Lyp clustering at the membrane when cells are on PLL suggest that they are very spherical and uniform, which may perhaps indicate a molecule that is somehow caged. The large Lyp spheres must through some unknown mechanism be positioned at the membrane. Accordingly, I explored the possibility that the microtubule network and/or the actin cytoskeleton motor proteins were involved in this positioning process.

Vehicle

ionomycin

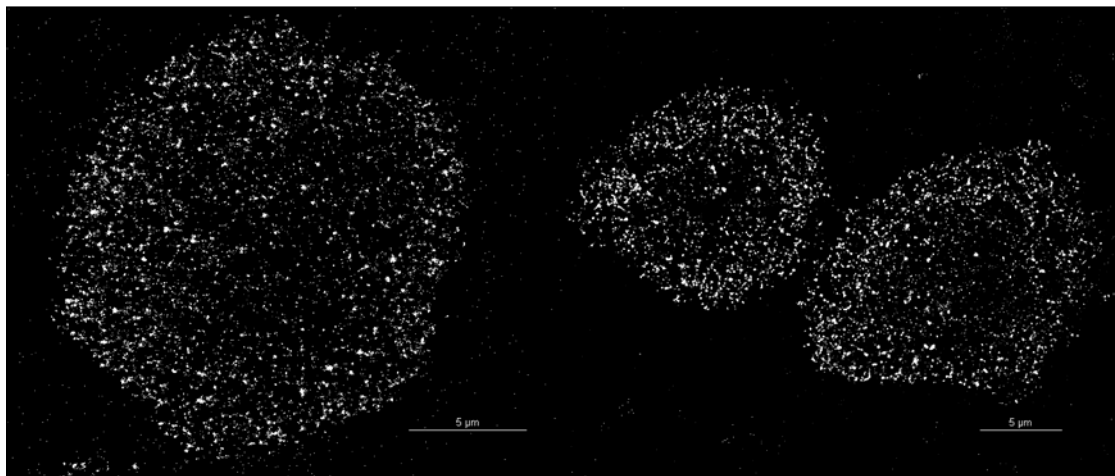

Figure 6.4: Declustering of Lyp in T cells is not dependent on calcium mobilisation. T cells were plated onto PLL and after 20 minutes were treated with ionomycin (1 μ g/mL) for 2 minutes and were then fixed and stained with an anti-Lyp antibody to monitor clustering. Images were acquired by TIRF-STORM.

The microtubule network and motor proteins play an important role in trafficking cargo around the cell. Experiments using nocodazole and blebbistatin indicated that both the microtubule network and motor proteins associated with the actin cytoskeleton were responsible for positioning Lyp clusters at the membrane at steady state. We could detect very few, or no molecules in the TIRF zone when treating T cells with these inhibitors (Figure 6.5). Thus, these large clusters may be trafficked around the cell in a microtubule and motor protein dependent manner. These results support the notion that Lyp clusters are contained or that Lyp molecules are interacting with one another or other proteins, facilitating the concerted movement of Lyp cargo along the microtubule network, delivering them in close proximity to the cell membrane. More experiments using confocal microscopy are needed here to find out exactly where Lyp is preferentially localising when these inhibitors are used. In addition, other inhibitors that have similar effects should be investigated to corroborate these data. Nevertheless, these experiments might provide some insight into Lyp dynamics and the importance of the microtubule and actin networks in positioning Lyp at or near the cell membrane.

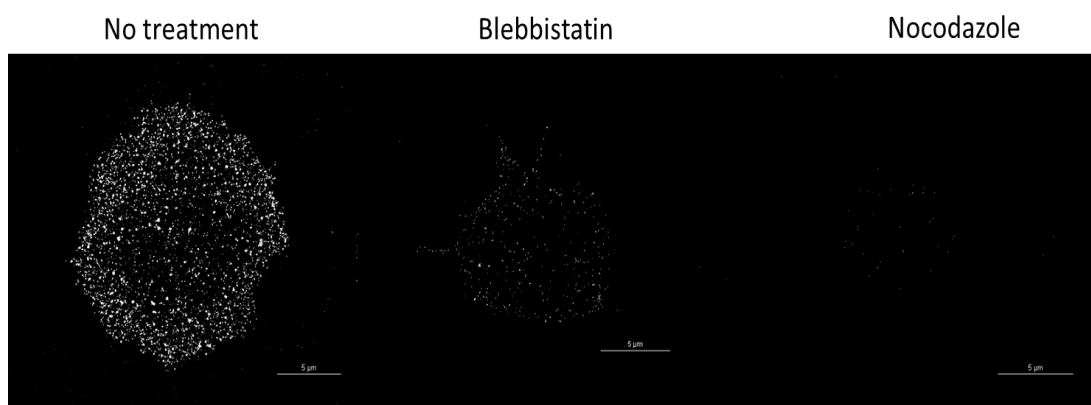
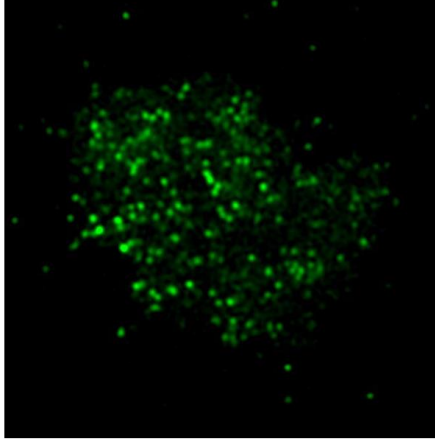

Figure 6.5: Lyp clustering and localisation at the plasma membrane is dependent on the microtubule network and associated motor proteins. T cells were plated onto PLL, treated with blebbistatin or nocodazole for 30 mins, fixed, stained with anti-Lyp and then imaged by TIRF-STORM.

Finally, to investigate Lyp cluster dynamics in real-time, primary T cells were transfected with a Lyp-GFP construct and were then dropped onto PLL. The cells were then imaged using TIRF-structured illumination (TIRF-SIM). Live cell imaging of a Lyp-GFP fusion protein demonstrated that clusters of Lyp were truly dynamic in their behaviour, in that they were not static. Interestingly, the large clusters appeared to display movement, however this movement was restricted laterally and instead it appeared as though the clusters were too-ing and fro-ing perpendicular to the plane of the membrane, as measured by the fluorescent intensity of the clusters over time Figure 6.6. This experiment in live cells formally demonstrated the existence of Lyp clusters at the membrane in T cells that were not obviously participating in signal transmission (or its regulation), faithfully reproducing with a fusion protein, the patterning of Lyp staining with antibodies.

(A)



(B)

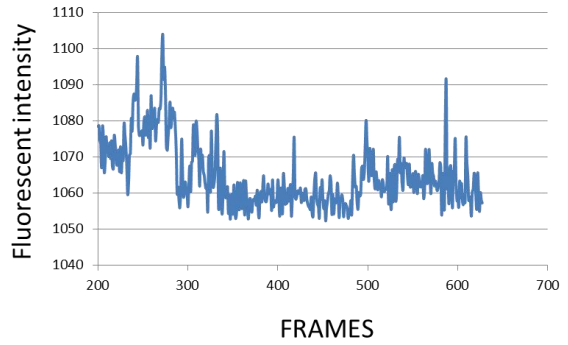

Figure 6.6: Lyp clusters display little lateral movement but appear to move into and away from (to-ing and fro-ing) the membrane. VIDEO ATTACHED TO THESIS ON CD.

(A) T Blasts were transfected with Lyp-GFP, rested for 24h in medium containing no IL-2 and then plated onto PLL. Videos were acquired by structured illumination microscopy

(B) Fluorescent tracking of single clusters reveals “To-ing and Fro-ing”. Individual clusters were encircled using a fixed perimeter and the fluorescent intensity of the cluster was tracked over time. Example of one cluster. 1 frame per second was collected.

6.3 Organisation of the disease associated Lyp mutant at the membrane of migrating cells.

Super-resolution microscopy may be useful in understanding how single amino acid changes in proteins that are associated with disease might display altered localisation. Using blood samples from the TwinsUK cohort at King's College London, it was feasible to use T cells from healthy donors homozygous for the disease associated variant R620W to understand how a mutation in the binding domain of Lyp alters its behaviour at the membrane, negating the need for overexpression studies and artefact arising from the genetic manipulation of T cells. Here, for the first time, super resolution was applied to the understanding of a single nucleotide polymorphism that associates with autoimmune disease. For all of the following experiments, parameters were fixed and all experiments were run in parallel, such that a direct and unbiased analysis of genetic variants of Lyp could be assessed.

T cell blasts derived from four Lyp-W620 homozygous and four Lyp-R620 homozygous donors (8 donors in total) were imaged migrating on ICAM-1. Under PLL conditions T cells from a total of eight Lyp-W620 homozygous and eight Lyp-R620 homozygous donors (total of 16 donors) were imaged. Two different antibodies were employed for the imaging, a mouse monoclonal antibody and a goat polyclonal antibody, for comparative purposes.

Figure 6.7 shows whole cell images and cluster maps from individual donors that were either homozygous for the disease associated Lyp-W620 or Lyp-R620. On PLL, as previously demonstrated, T cells from Lyp-R620 donors displayed highly organised Lyp clusters at the membrane, while cells from Lyp-W620 donors appeared to display

similar molecular organisation at the membrane. Given that Lyp localises mainly to the leading edge of migrating T cells, analysis was focused on regions at the leading edge where co-localisation with Lck, ZAP-70 and Vav was previously shown to be most prominent (see Chapters 3 and 5). It was noted that very little Lyp could be detected in the midcell zone, with some Lyp detectable in the lagging edge of migrating cells, consistent with images acquired by confocal imaging. The leading edge, for the purposes of this study, was defined by the Lyp exclusion zone within the midcell region, and all regions of interest in the leading edge were taken from areas in front of the exclusion zone. When T cells migrated on ICAM-1, Lyp-R620 recapitulated our previous results in that the large clusters were no longer apparent, and instead a more diffuse Lyp patterning was observed, comprising smaller clusters that were not very dense when normalised to the rest of the molecules within the region of interest; this was confirmed by the cluster heatmaps. T cells from the Lyp-W620 donor appeared to follow a similar pattern. However, upon closer inspection of the apparent number of localisations of Lyp-R620 versus the Lyp-W620, we noted a deficit of molecules in Lyp-W620 expressing T cells. In addition, the heat maps suggested that the smaller clusters observed in the Lyp-W620 were more clustered, as displayed by the orange to red colours centred in the middle of the clusters, with the Lyp-R620 being more blue or less clustered. The overall organisation of the Lyp, however seemed similar, with no stark differences between the genotypes. To understand whether or not these maps translated into meaningful differences, a quantitative analysis was performed where the number of molecules detected, the percentage molecules clustered, the number of clusters, the number of molecules per cluster and cluster size in the homozygotes versus the wild type donors could be directly compared. In addition, clustering was functioned by generating curves using Ripley's K function

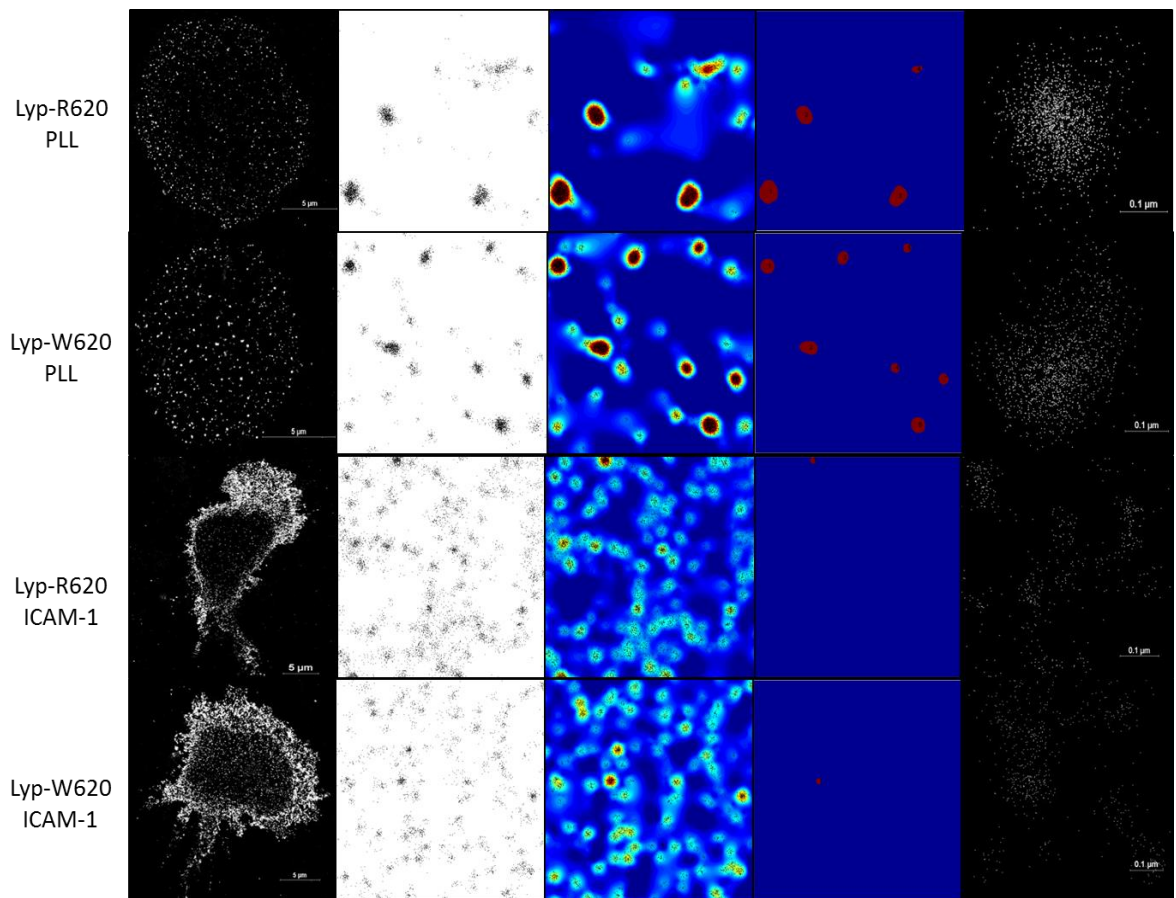

Figure 6.7: Cluster maps for Lyp-R620 and Lyp-W620 expressing T cells in conditions of immobilisation (PLL) or migration (ICAM-1). T cells from genotyped individuals were plated onto PLL or ICAM, fixed, stained with anti-lyp and imaged by TIRF-STORM. Representative whole cell images, individual localisations, heatmaps, binary cluster maps and zoomed regions. The individual localisations, heatmaps and binary maps are 2X2μm regions.

6.4 Less Lyp-W620 can be detected at the leading edge membrane in migrating T cells.

To assess the number of localisations at the leading edge of migrating T cells, regions of interest were selected and the number of molecules detected in these regions was calculated. Despite not being able to calculate the labelling ratio of antibody:protein, one might assume that all areas of the cell would be labelled similarly, and so any differences between the regions selected will represent actual protein abundance, or a good relative estimate thereof.

On PLL, no significant differences in molecule counts between Lyp-R620 and Lyp-W620 expressing T cells could be observed (Figure 6.8). This suggested that when cells weren't signalling through LFA-1, a comparable amount of Lyp was present at the membrane, as demonstrated by two different anti-Lyp antibodies. In contrast, when T cells migrated on ICAM-1, a deficit of Lyp molecules appeared to occur in the leading edge of T cells from Lyp-W620 donors (mouse antibody= \sim 20% less localisations, goat antibody= \sim 30% less localisations). Thus it became apparent that under conditions of migration, where large clusters were much less apparent, there was an inability of Lyp-W620 to remain at, or be recruited to, the membrane.

To ensure Lyp expression was not affected by the mutation, anti-Lyp immunoblots were performed. These experiments demonstrated that there was no significant difference in Lyp expression, nor the ability of the antibody to recognise Lyp-R620 or Lyp-W620. Thus it seemed a true deficit of molecules existed at the plasma membrane in migrating cells, while no such deficit could be detected under PLL conditions,

indicating that the machinery responsible for positioning Lyp at the membrane was unaffected, and that the mutation within the binding domain did not compromise Lyp localisation in the steady state. Furthermore, the data, together with the results of my biochemical signalling experiments, indicated that the binding domain mutation might compromise Lyp function mainly during the process of active signalling.

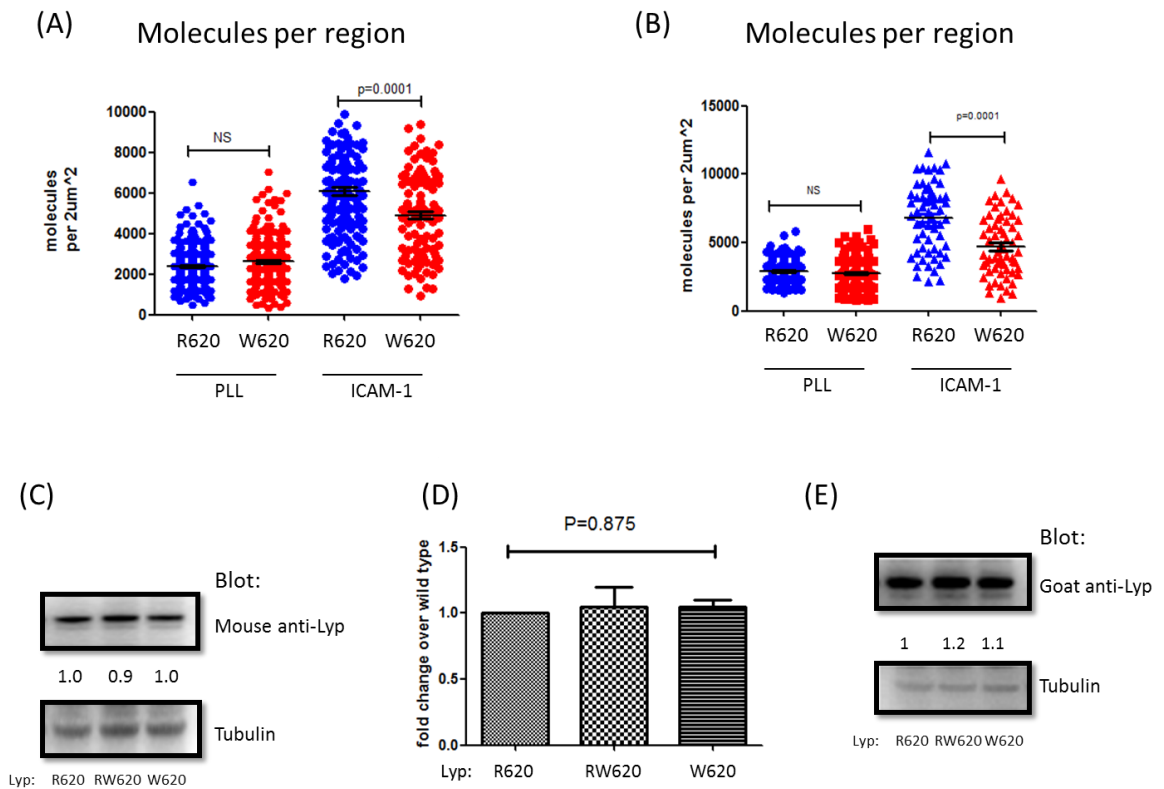

Figure 6.8: Lyp-W620 does not localise efficiently to the membrane in migrating T cell blasts.

R620 = homozygous for major allele

RW620 = heterozygous

W620 = homozygous for minor allele

(A) Mouse anti-Lyp number of localisations detected

(B) Goat anti-Lyp number of localisations

(C+E) Whole cells lysates made from genotyped cells demonstrate no difference in Lyp expression using a mouse anti-Lyp and Goat anti-Lyp antibody

(D) Pooled experiments from 6 experiments demonstrating no difference in Lyp expression between RR, RW and WW donors.

N=at least four donors for each genotype

6.5 Disease associated Lyp-W620 is more clustered at the plasma membrane when T cells migrate

To identify whether or not a mutation in the binding domain of Lyp influenced clustering of Lyp at the membrane, the percentage of molecules participating in clusters was investigated. Given that Lyp declusters when LFA-1 binds to ICAM-1, and that biochemical analysis of the Lyp-W620 mutant indicated hyperphosphorylated Vav and Erk when T cells migrate on ICAM-1, I wanted to test whether declustering was somehow perturbed. If the disease associated Lyp failed to de-cluster or if its localisation at the membrane was affected once exiting a cluster, the percentage of Lyp participating in clusters might in some way be altered.

Under PLL conditions, no differences in the percentage of molecules participating in clusters could be detected using a goat and a mouse antibody (Figure 6.9). When T cells migrated on ICAM-1, a dramatic reduction in Lyp clustering was observed with ~10 fold decrease in numbers of molecules participating in clusters. Small but significant differences in clustering between Lyp-R620 and Lyp-W620 were observed when T cells migrated on ICAM-1 (mouse≈3% increase, goat≈2% increase $p=0.01$ and $p=0.0024$ respectively). These small but significant differences indicated that more Lyp-W620 in the regions of interest analysed was participating in clusters when compared to Lyp-R620.

The biochemical-imaging correlate of Lyp targeting substrate when it de-clusters, and the hyperphosphorylation of Erk in Lyp-W620 expressing T cells, could indicate that either Lyp was failing to de-cluster properly, or, upon Lyp de-clustering, the free molecules were unable to be retained at the membrane. Clearly, from these results, both Lyp variants were declustering, as demonstrated by a large drop in clustering when cells migrated on ICAM-1 as compared to the highly clustered status of Lyp in the PLL conditions. The differences in the percentage molecules participating in clusters

were very subtle in the ICAM-1 conditions between the two genotypes. This lead us to believe that the cluster parameters could be comparable between the genotypes when the T cells migrated, and that actually the percentage molecules participating in cluster values were in fact increased due to the lack of monomers. This is in good agreement with Figure 6.8 that shows a clear deficit of molecules at the leading edge of migrating T cells. Thus, the parameters of individual clusters were investigated to understand whether or not the result was due to a true increase in clustering behaviour, or a deficit in free molecules.

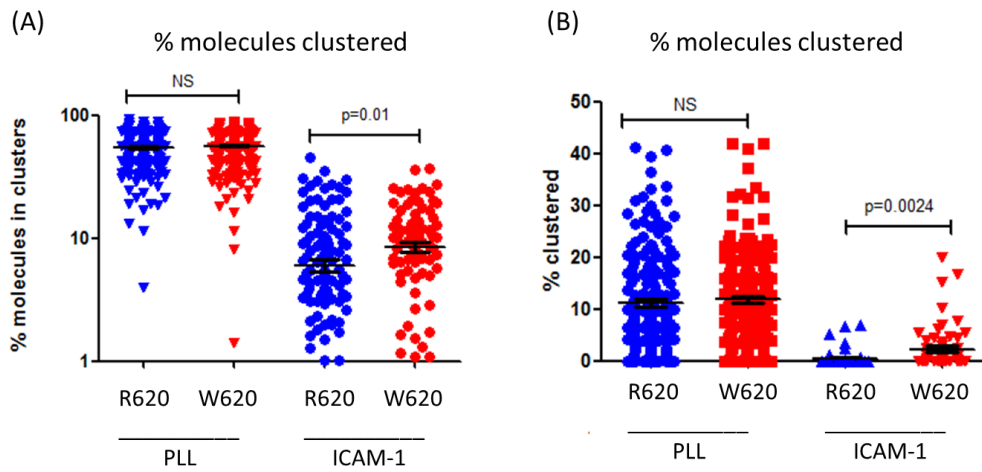

Figure 6.9: Lyp-W620 is more clustered at the membrane in migrating T cells.

(A) Mouse anti-Lyp: percentage of molecules participating in clusters

(B) Goat anti-Lyp: percentage of molecules participating in clusters.

N=at least four donors for each genotype

6.8 Lyp clustering is unperturbed by a mutation in a polyproline binding domain

The parameters of the clusters identified in T cells from Lyp-R620 and Lyp-W620 donors might indicate whether there exist differences in the ability of Lyp to cluster. Despite being unsure at this point about the mechanisms behind cluster formation, it was possible to objectively analyse individual clusters identified by the algorithm to understand the number of molecules participating in individual clusters and the size of individual clusters.

The analysis revealed that, despite large molecule deficits observed in Figure 6.8, the total number of molecules participating in clusters, as well as the diameters of the clusters were not statistically different between genotypes (Figure 6.10 and 6.11). On PLL it was clear that the average size of clusters was larger than that of cells migrating on ICAM-1. This correlated well with molecule counts per cluster, which were decreased in migrating T cells. Thus, we conclude that a mutation within the binding domain of Lyp does not lead to perturbations in clustering behaviour, but rather perturbations in the way in which the monomers were behaving and failing to localise at the membrane. The 20-30% decrease in molecule counts observed must therefore be due to a loss of Lyp monomers due to it not being retained near the membrane zone.

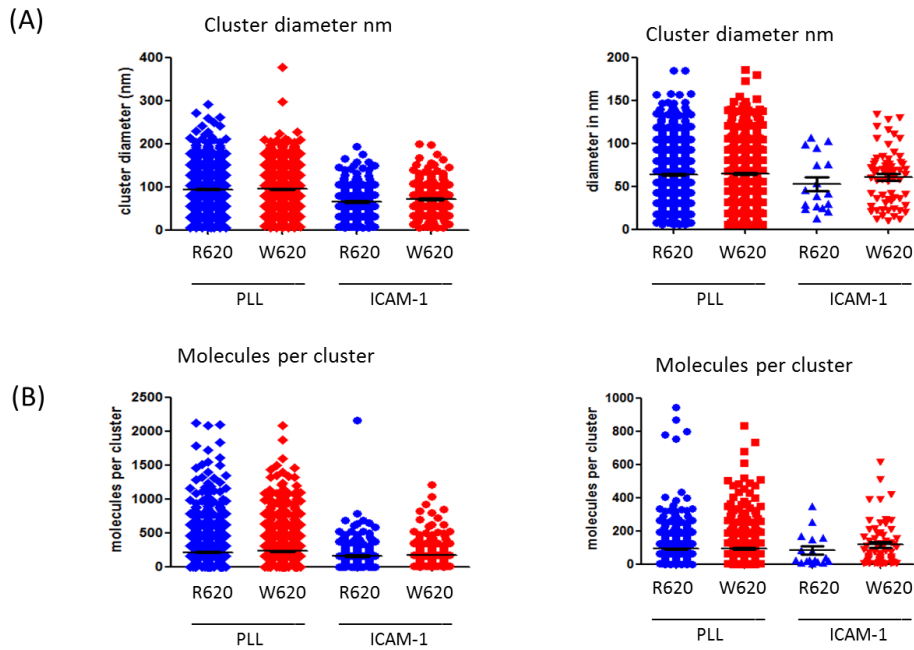

Figure 6.10: The size and cluster composition of Lyp-R620 and Lyp-W620 are similar at the leading edge.

(A) Cluster diameter as calculated using mouse (left) and goat (right) antibodies

(B) Molecules per cluster as calculated using mouse (left) and goat (right) antibodies

N=at least four donors for each genotype

Finally, to understand whether there was a difference in the number of clusters present at the plasma membrane in PLL immobilised and migrating cells we

enumerated the number of clusters per region of interest. Given that there were no differences in the nature of clusters, as demonstrated by size and number of molecules participating in clusters, an increase or decrease in the number of clusters might indicate whether there was a deficit or accumulation of clusters at the plasma membrane in migrating cells.

As expected, there were no differences between genotypes in terms of the number of clusters found at the plasma membrane when T cells were immobilised on PLL, in keeping with no changes in any of the other parameters investigated (Figure 6.11). On ICAM-1 there was an increase in the number of clusters in the Lyp-W620 as compared to Lyp-R620, but this difference did not reach statistical significance ($p=0.07$). In contrast, the goat antibody suggested that Lyp-W620 had a statistically significant increase in the number of clusters per region as compared to the Lyp-R620 ($p=0.0004$). The difference in these findings might be reconciled by the specificity of the two antibodies, and the importance of such a finding when looking more closely at the data. The mouse monoclonal antibody was clearly more able to pick up clusters as demonstrated in Figure 6.1, where on PLL ~60% of Lyp was clustered, whereas the goat only detected around ~10% of molecules clustered. It is therefore tempting to speculate that the goat antibody might not be as specific. When looking over the regions investigated for numbers of clusters, it was obvious that the goat antibody was able to detect very few clusters in T cells from both the Lyp-R620 and Lyp-W620 donors when migrating, as compared to the mouse antibody. Over a total of 60 regions for the Lyp-R620 donors, only 7 regions contained clusters, amounting to a total of 12 clusters. 28 of the 53 regions contained clusters in Lyp-W620 expressing T cells. Upon closer inspection, the average number of clusters per region for the mouse anti-Lyp

antibody was 0.2, whereas for the goat antibody 0.8 clusters per region were detected. Given that the mouse antibody detected no differences in number of clusters, and the actual small difference in the goat antibody investigations (less than 1 cluster/field of view for both genotypes), the statistically significant result of the goat antibody was questioned in terms of its biological significance. Thus, it might be concluded that there were no differences between the two genotypes when investigating the number of clusters per field of view, although we cannot completely exclude the possibility that, as a result of a deficit of molecules at the plasma membrane, the cell is trying to compensate for a lack of regulation, leading to more Lyp clusters being recruited/delivered to the membrane.

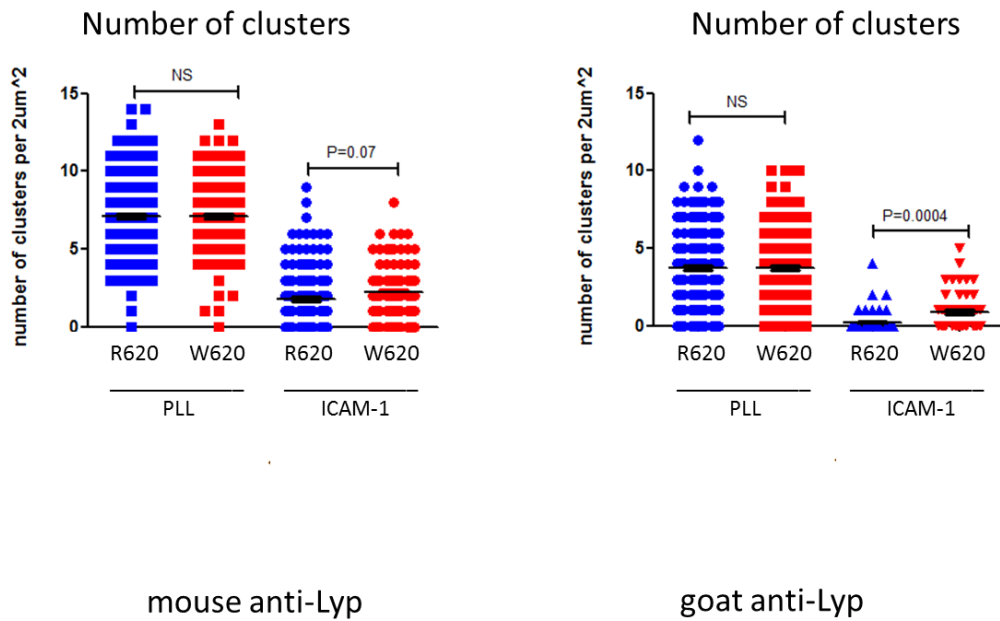

Figure 6.11: The number of clusters is slightly increased in W620-Lyp donors

(A) Mouse anti-Lyp: number of clusters per region

(B) Goat anti-Lyp: number of clusters per regions

N=at least four donors for each genotype

6.10 Ripley's K function reveals that Lyp-W620 is more clustered than Lyp-R620 at the membrane in migrating T cells.

Ripley's K-function can be used to generate curves that demonstrate the level of clustering over different length scales. By generating these curves for T cells from each genotype, we could directly assess the length scale over which the clustering was maximal. Another advantage to doing this analysis is the ability to discern from the curves, as one moves from the centre of clusters outward, how quickly the molecular density decreases. The analysis so far has demonstrated that there are no differences in the nature of the clusters between the two genotypes, with cluster size and number of molecules per cluster being comparable. By plotting the Ripley's K-function, a more unbiased approach that does not rely on a preselected radius to analyse clustering or the thresholding of a pseudo-coloured map following an interpolation of molecular scores to visualise and quantify cluster formation, it was possible to interpret Lyp clustering as a function of length. The hypothesis that Lyp was unable to localise at the membrane following de-clustering could be supported from The Ripley's curves generated. Figure 6.12 demonstrates that R620-Lyp was less clustered than W620-Lyp. The peak of the curve was higher for W620-Lyp indicating that regions analysed in the front of the cell were more clustered in comparison to the R620-Lyp regions, where the peak was below that of W620-Lyp. Interestingly, the gradient of the curve was significantly steeper for Lyp-W620 versus Lyp-R620. An increase in the rate at which clustering is lost as one moves from the centre of the cluster outward might be interpreted in the following way, and may explain why the algorithm used views the Lyp-W620 as being more clustered despite the actual clusters themselves being

comparable in nature. The molecule deficits demonstrated at the membrane in Lyp-W620 expressing T cells occurred only when cells were signalling, and not when immobilised on PLL. These molecule deficits were correlated with a large de-clustering event, in which less clustered Lyp could be detected at the membrane in both genotypes when T cells migrated on ICAM-1. If the molecules leaving the cluster were unable to be retained at the membrane one would expect a steeper gradient on the down slope when plotting Ripley's K -function. This is because, any cluster of molecules surrounded by less monomers is by definition more clustered. Thus, if molecules were not being retained at the membrane within the TIRF zone, Lyp clusters in Lyp-W620 expressing T cells will be more clustered on a unit measurement scale, despite them actually being very similar to the wild type clusters. If this were the case, the gradient on the Ripley's curve would be expected to be steeper as one moves away from clusters, because molecules are being lost, and so cluster values would be increased. This phenomenon is directly demonstrated from the generation of Ripley's Curves, and points to an inability of Lyp-W620 monomer retention at the membrane when T cells migrate on ICAM-1. In fact, the Ripley's downslope gradient is twice as high for Lyp-W620 as compared to Lyp-R620. These data might suggest that upon exiting a cluster, Lyp is not retained at the membrane, but the clusters themselves appear to be unperturbed by the same mutation.

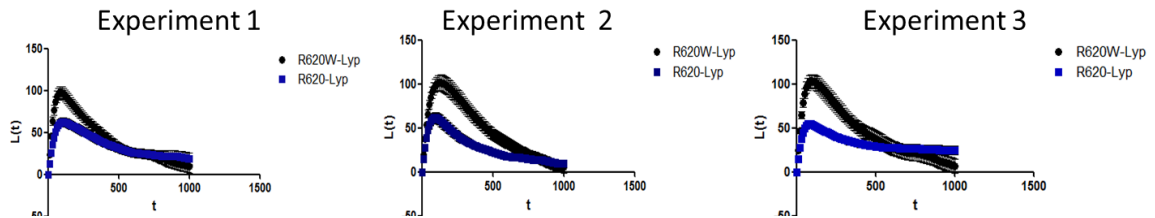

Figure 6.12: Lyp-W620 clusters to a greater extent at the membrane than Lyp-R620 when T cells migrate on ICAM-1. Ripley's K-function reveals that R620W-Lyp is more clustered than R620-Lyp donors across all experiments. The Ripley's K function was calculated using at least 25 leading edge regions per donor using the mouse-anti-Lyp antibody. Representative of at least 3 donors per genotype.

6.11 Modelling reveals that molecules outside of the cluster can dictate the downslope of Ripley K function.

In generating Ripley's curves for Lyp-R620 and Lyp-W620 clustering, a striking difference in the linearity of the curves was observed when T cells migrated on ICAM-1. The curves demonstrated that Lyp-W620 had a much higher gradient as compared to the Lyp-R620. The difference in the Ripley's curves was only observed under conditions where the cell was actively integrating signals through LFA-1, suggesting that it was under signalling conditions that a difference in Lyp behaviour could be observed. Thus, I sought to model molecular distributions of molecules by investigating how different datasets impacted the nature of the Ripley's curve. This work was done with Sophie Minoughan, a second year physics student.

To model how the size of a cluster made up of a fixed number of molecules changes the shape of the Ripley's curve, random datasets were generated using randomly distributed data plots in the software package Excel. A normal distribution function produced points within a range of 0-3000, with the clusters centred within the middle of the range scale ($x=1500\text{nm}$, $y=1500\text{nm}$) with varying standard deviation (100-500 in increments of 100). The total number of events per region totalled 1000, with 500 of these events being assigned to a cluster, whilst the rest of the events were randomly distributed throughout the region, with the only stipulation being that they must lie within the range of 0-3000 in order to remain within the set region (0-3000). The Ripley's curves corresponding to smaller standard deviations had a higher peak than plots corresponding to a higher standard deviation, as expected (Figure 6.13). The

standard deviation essentially dictated the density of the cluster, whilst events outside of the cluster remained similar, which in turn dictated the amplitude of the curve. This indicates a higher instance of clustering correlates to a more pronounced peak in the Ripley's K function.

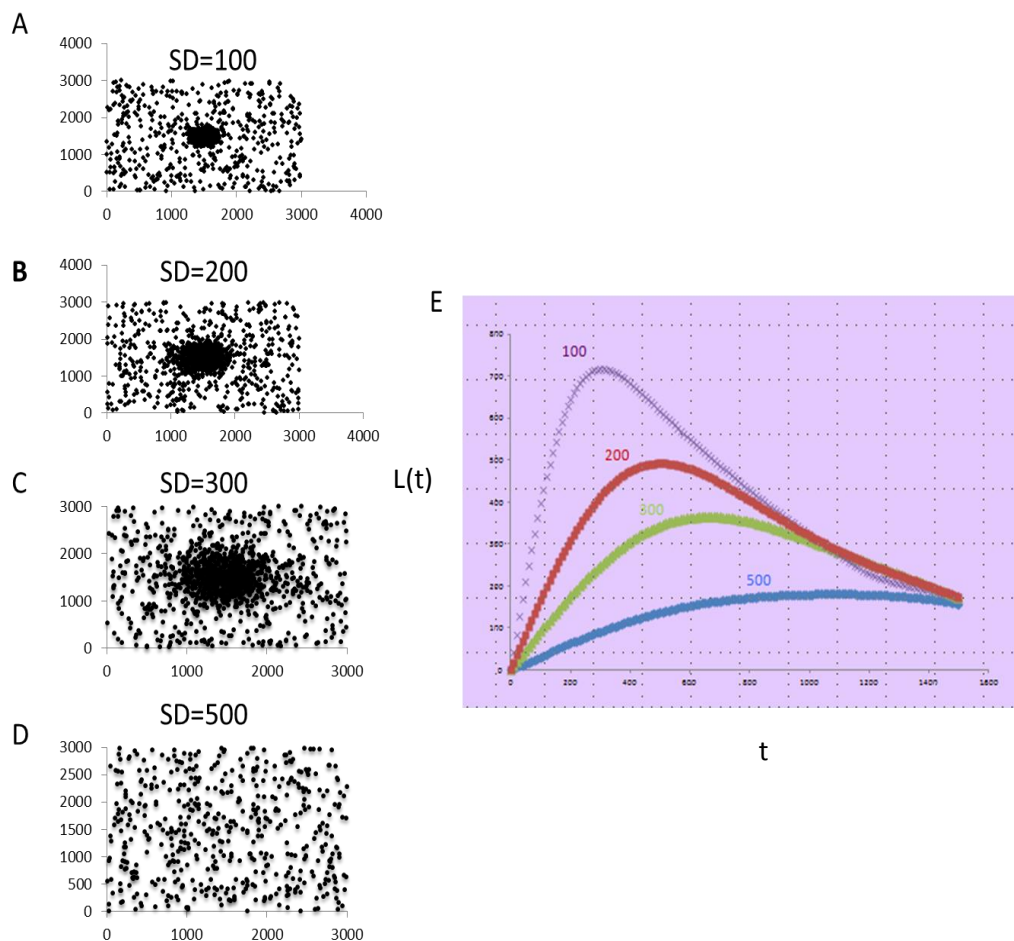

Figure 6.13: Mathematical modelling of the downslope of Ripley's K Function. A-D)

Clusters of different sizes were generated using a normal distribution function in Excel, and (E) the Ripley's K function was plotted from these different size clusters. 1000 points were used per region. Data generated with Sophie Minouhan

In order to determine the effect of monomers on the Ripley's K function, the model was altered to produce different amounts of monomers or events outside of the cluster. The cluster parameters were kept constant, with 500 molecules making up a cluster with a standard deviation of 100, whilst the number of background events was decreased from 500 to 0 in decrements of 100. A ratioetric change in number of events inside a cluster versus the number of events outside the cluster is indicated above the graphs (Figure 6.14). The results showed that the peaks of the Ripley's K function became more defined when there were fewer background monomers; they also showed the downward slope of the curve to approach linearity as the background monomers decreased. These observations were further characterised using the R^2 values of the downward slopes. The R^2 values are closer to 1 for the cases of fewer background monomers, thus indicating a linear relationship (Figure 6.15). These results indicate an observed linear downward slope of the Ripley's K function that corresponds to a sample containing small amounts of background monomers. Finally, when the background was removed from the initial cluster regions, the Ripley's K functions for each of the regions showed the peak to be higher and more prominent in the absence of background monomers (Figure 6.16). This result could be seen regardless of the standard deviation of the clusters (data not shown).

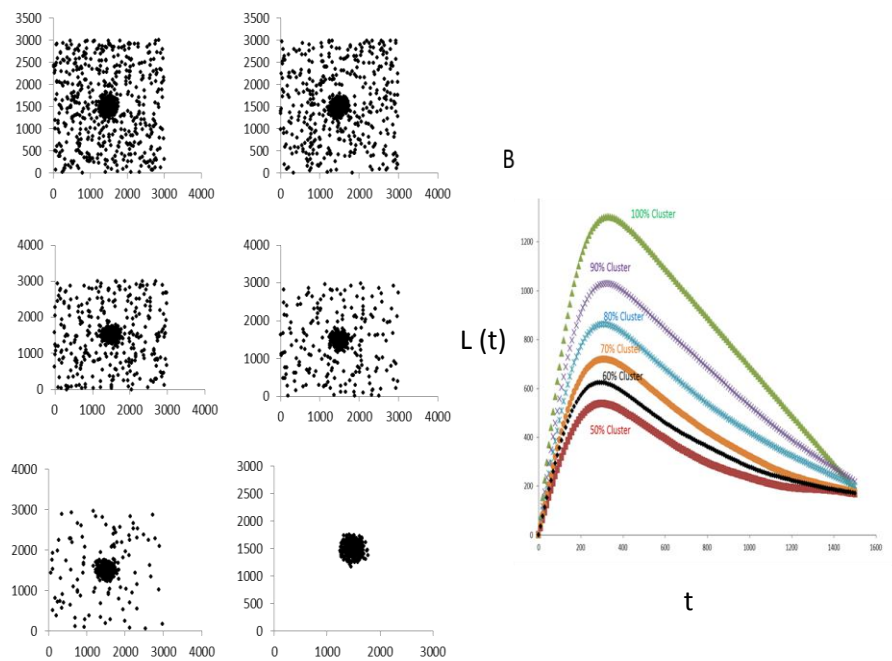

Figure 6.14: Mathematical modelling of clustering dynamics. A) The number of molecules per cluster was fixed and different number of background monomers were used to understand the influence of points outside of clusters on the downward slope of Ripley's K function as depicted in (B). Data generated with Sophie Minoughan

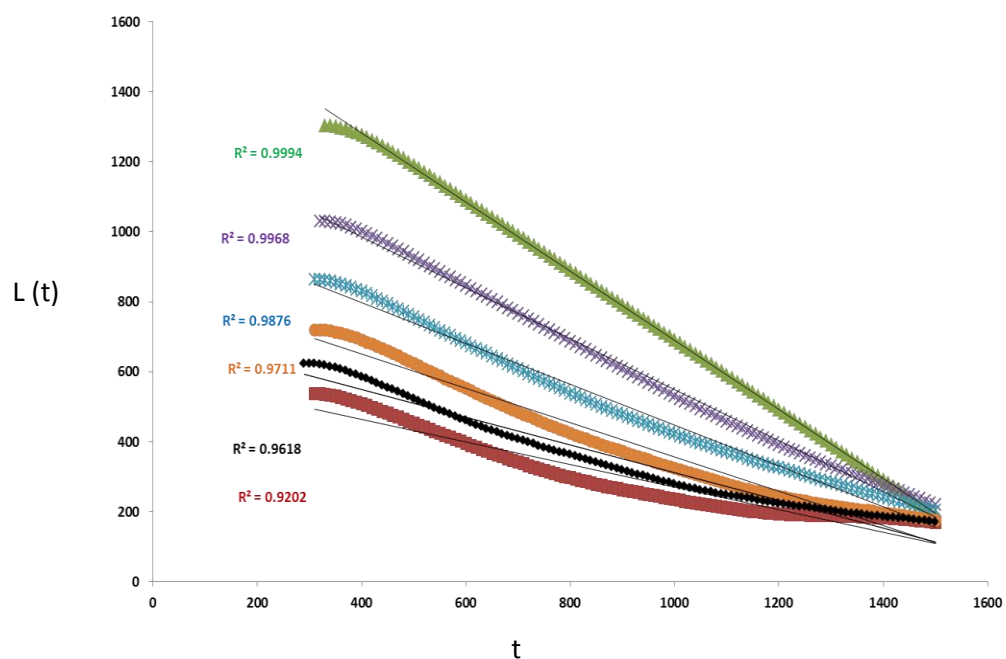

Figure 6.15: Mathematical modelling of clustering dynamics. The downward slopes from Fig 6.14 are plotted with the percentage molecules participating in clusters denoted on the graph, with the corresponding R^2 values of each curve. Data generated with Sophie Minoughan

6.12 Lyp-W620 is associated with increased LFA-1 clustering when T cells migrate on ICAM-1

A key step in integrin biology leading to firm adhesion is the clustering of integrin complexes at the cell surface, termed avidity maturation. Avidity maturation occurs when integrins cluster and is a process that is thought to be partly driven through integrin signalling and mechanotransduction, although the actual steps of this process are only just beginning to be understood. In the following experiments, I investigated LFA-1 clustering in migrating T cell blasts expressing Lyp-W620. The experimental set up mirrored exactly that of Lyp super resolution imaging, with the exception that a primary antibody directed specifically at the CD11a chain of LFA-1 was used to monitor clustering of LFA-1 at the surface of fixed, unpermeabilised cells.

Figure 6.17 demonstrates representative examples of T cells from genotyped donors migrating on ICAM-1, with heat maps demonstrating regions under higher magnification corresponding to the front of the cell. It was clear from the heat maps that LFA-1 was more clustered in T cells expressing Lyp-W620, and that this clustering was very striking.

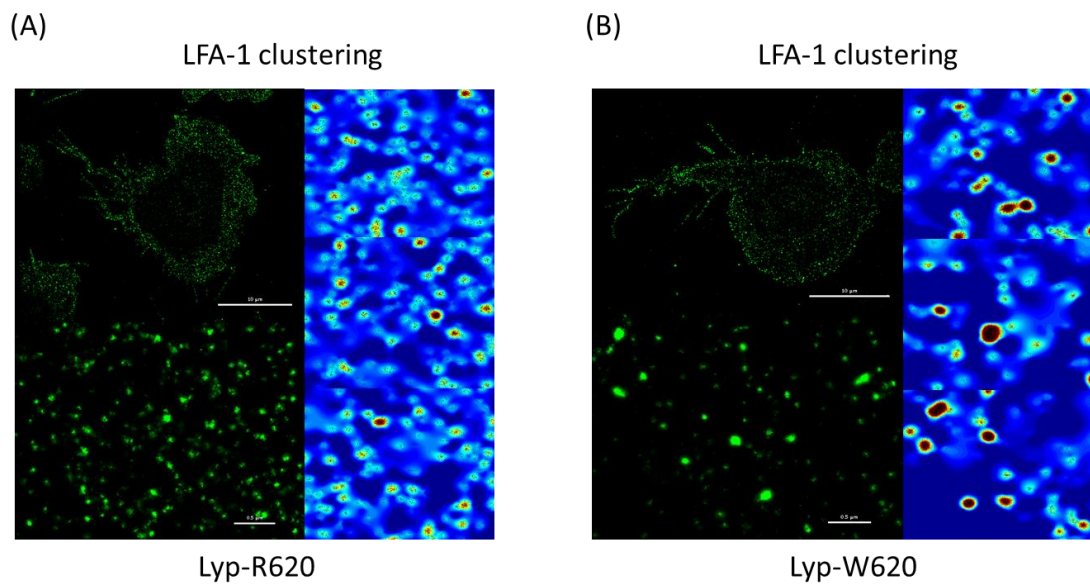

Figure 6.17: LFA-1 cluster maps at the leading edge of migrating T cells expressing Lyp-R620 or Lyp-W620. T cells from genotyped individuals were plated onto ICAM-1 and then fixed after 10 mins and stained with a mouse anti-LFA-1 antibody followed by incubation with an anti-mouse secondary conjugated to AF647. Images were acquired by TIRF-STORM. A) LFA-1 clustering in R620-Lyp donors and B) LFA-1 clustering of Lyp-W620

A more detailed quantitative analysis revealed that there were no differences in the amount of LFA-1 present at the surface of Lyp-R620 or Lyp-W620 expressing T cells (Figure 6.18). Thus, despite similar levels of LFA-1 detected at the surface of cells, the percentage of molecules participating in clusters between the genotypes displayed more than a two-fold difference. The number of LFA-1 molecules participating in clusters increased from 19% in Lyp-R620 expressing T cells to 43% in Lyp-W620 expressing T cells (Figure 6.19). In addition, the sizes of the clusters were increased, more clusters could be detected and more molecules per cluster were clearly observed associated with Lyp-W620 as compared to Lyp-R620 (Figure 6.20-22). The plotting of Ripley's K function demonstrated that across all donors, LFA-1 in Lyp-W620 expressing T cells was more clustered, and in line with our model, displayed a more linear downward slope suggesting that there were fewer monomers of LFA-1, because most of the LFA-1 was sequestered into clusters (Figure 6.23).

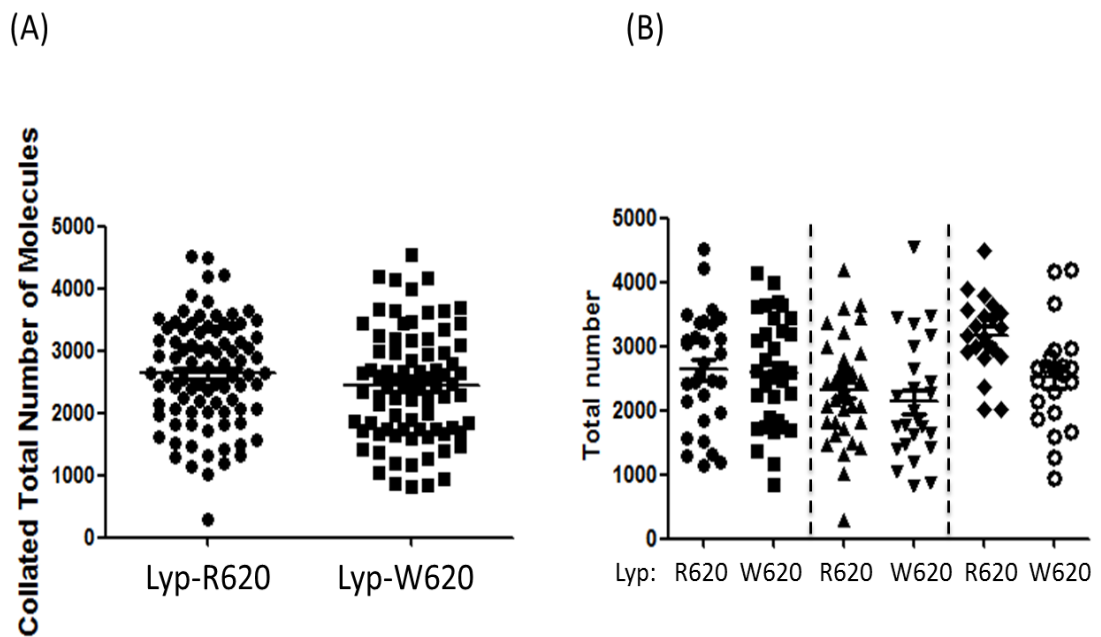

Figure 6.18: Quantitative analysis of LFA-1 molecules at the leading edge of Lyp-R620 and Lyp-W620 expressing T cells.

(A) Pooled data from 3 R620-Lyp donors and 3 W620-Lyp donors demonstrating molecule counts

(B) Individual experiments from (A) demonstrating molecule counts for individual donors

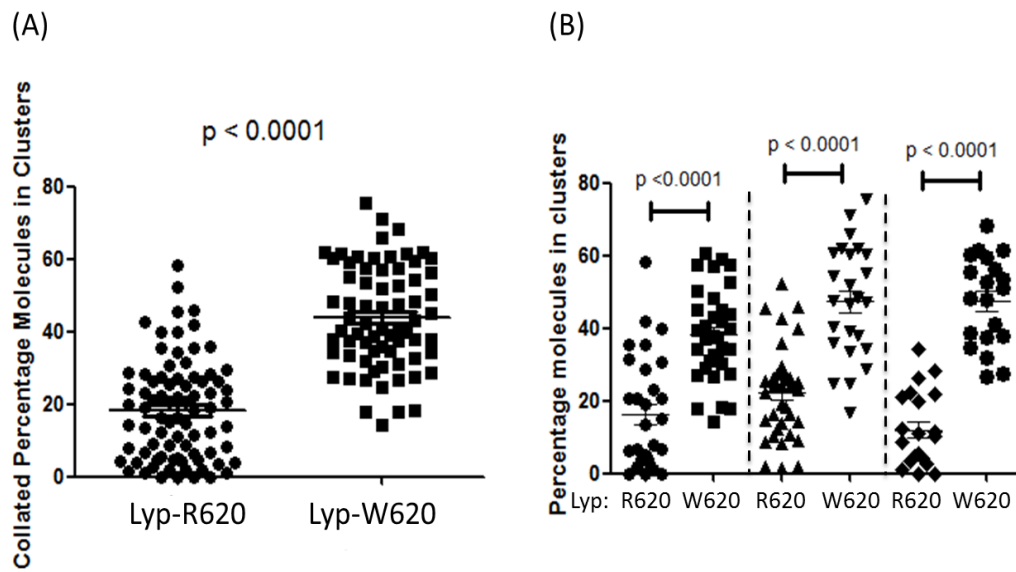

Figure 6.19: Analysis of LFA-1 clustering at the leading edge of Lyp-R620 and Lyp-W620 expressing T cells.

(A) Pooled data from 3 R620-Lyp donors and 3 W620-Lyp donors demonstrating percentage molecules in clusters

(B) Individual experiments from (A) demonstrating percentage molecules clustered for individual donors

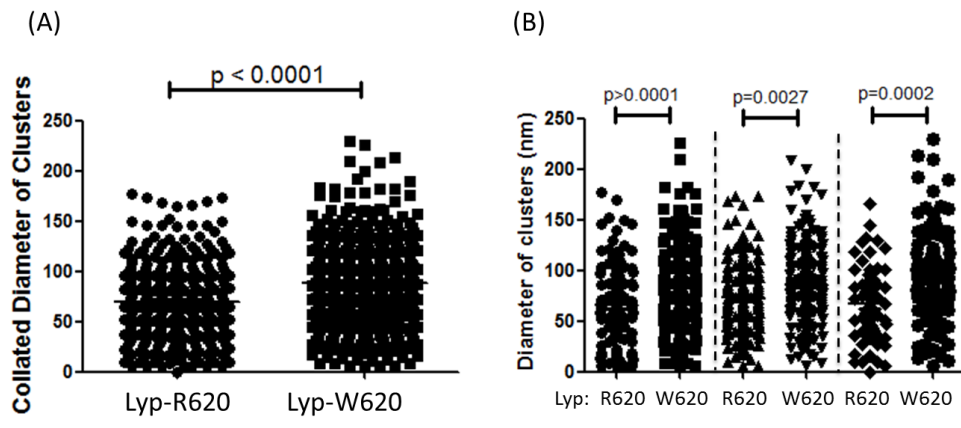

Figure 6.20: Diameter of LFA-1 clusters at the leading edge of Lyp-R620 and Lyp-W620 expressing T cells.

(A) Pooled data from 3 R620-Lyp donors and 3 W620-Lyp donors demonstrating diameter of clusters

(B) Individual experiments from (A) demonstrating diameter of clusters for individual donors

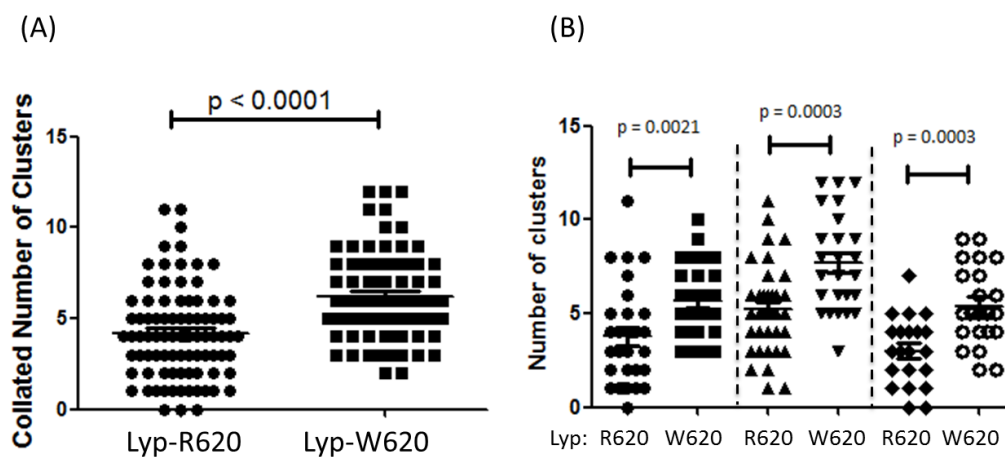

Figure 6.21: Quantitative analysis of LFA-1 clusters at the leading edge of Lyp-R620 and Lyp-W620 expressing T cells.

- (A) Pooled data from 3 R620-Lyp donors and 3 W620-Lyp donors demonstrating number of clusters
- (B) Individual experiments demonstrating from (A) demonstrating number of clusters for individual donors

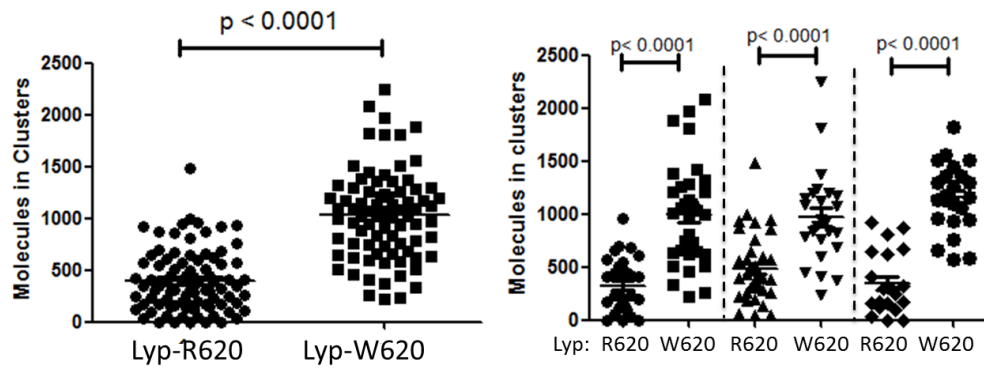

Figure 6.22: Quantitative analysis of LFA-1 molecules clustering at the leading edge of Lyp-R620 and Lyp-W620 expressing T cells.

(A) Pooled data from 3 R620-Lyp donors and 3 W620-Lyp donors demonstrating molecule in clusters

(B) Individual experiments from (A) demonstrating molecules in clusters for individual donors

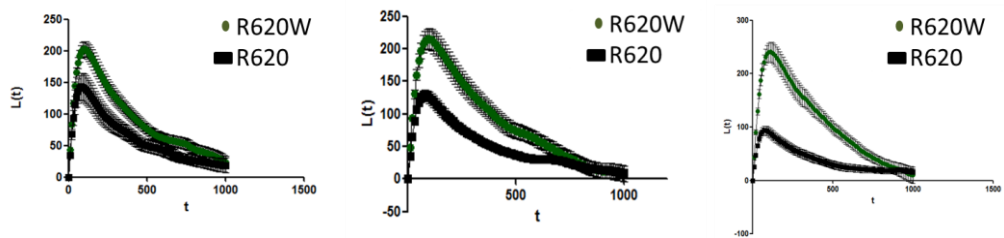

Figure 6.23: Ripley's curves describing cluster patterns for LFA-1 in Lyp-R620 and Lyp-W620 T cells migrating on ICAM-1.

A total of 25 regions per donor were used to generate Ripley's K function for R620-Lyp and R620W-Lyp donors.

These results strongly suggest that LFA-1 clustering is associated with fewer Lyp monomers at the plasma membrane of migrating T cells, providing further evidence that a mutation in the binding domain of Lyp perturbs negative regulation of integrin signalling manifest by increased adhesion complexes at the cell membrane, and increased adhesion and deregulated migratory function.

Discussion

Super resolution imaging can provide spatial information pertaining to the arrangement of molecules at the cell membrane (Sherman, Barr et al. 2011, Williamson, Owen et al. 2011, Brown, Dobbie et al. 2012). Here, I used a mode of super resolution imaging called STORM (Rust, Bates et al. 2006, Folling, Bossi et al. 2008, Heilemann, van de Linde et al. 2008) to better understand 1) the way in which Lyp is arranged at the cell membrane in resting and migrating primary T cells and 2) the consequence of a binding domain mutation on integrin clustering.

Investigating migration, and in particular the migration machinery that resides within or proximally to the membrane, is well suited to the imaging approach taken here. It is noteworthy, however, that Lyp organisation more than 100nm away from the cell membrane into the cell was not investigated due to the complications that arise from background. These background issues mainly centre on the illumination of the whole sample rather than one plane of interest, leading to interference fluorescence from molecules outside of the plane of interest due to the beam path of the laser. Thus, the organisation of Lyp within the cytoplasm requires further investigation.

T cells migrate at very fast speeds, with velocities of up to 40 μ m/min. This made live cell super resolution by storm imaging technically challenging, due the number of localisations required in order to be able to build up an image consisting of enough localisations for analysis. For this reason, all imaging was undertaken using fixed migrating cell. An alternative method to STORM is the use of structured illumination (SIM); a technique that can acquire images much faster (Schermelleh, Carlton et al. 2008, Rego, Shao et al. 2012). Using SIM, it was possible to image live cluster dynamics

in T cells immobilised on PLL using a Lyp-GFP constructs. These data demonstrated that, in line with the results obtained by immunostaining, large clusters existed at the cell membrane (Figure 6.6 video 1). These videos demonstrated a very interesting dynamic of the large clusters observed. Instead of the clusters moving laterally, there appeared to be movement in the Z-plane, perpendicular to the membrane and glass slide, indicating that the clusters were “bobbing” in and out towards the membrane.

Both the live cell imaging of a GFP fusion proteins and an immuno-stain indicated that large clusters of Lyp existed at the plasma membrane. A cluster analysis performed on cells immobilised on PLL indicated that Lyp existed in large clusters that contained, in some cases, thousands of molecules. When migrating on ICAM-1, the large clusters appeared to break up into smaller clusters that were less dense and many more molecules could be detected outside of clusters, suggesting that perhaps a gating mechanism existed whereby Lyp was in some way packaged at the membrane in a vesicle or contained in large clusters through interactions with scaffolding proteins or possibly even homotypic interactions. Currently, work is underway to understand whether or not lipid stains colocalise with these large clusters, which might suggest that the clusters are indeed packed and delivered to the plasma membrane along the microtubule network (figure 6.5). If it turns out that Lyp is indeed within a vesicle at the membrane, and that the vesicle somehow is “emptied” at the membrane, a completely novel way in which intracellular signalling molecules are regulated could be revealed.

Given that vesicles have been demonstrated to be controlled by calcium binding to synaptotagmins that then catalyse the formation of trans-SNARE complexes between two opposing membranes leading eventually to the release of vesicular components by membrane fusion (Wickner and Schekman 2008), calcium fluxing experiments were performed to investigate whether calcium signalling played a role in Lyp de-clustering. Experiments using ionomycin argue against calcium signalling as a driver of Lyp de-clustering. On the other hand, experiments revealed that an intact microtubule network is required in order to deliver Lyp clusters into the TIRF zone. Given the increasing appreciation of sub-cellular compartments, and the reaction times needed for signal transduction events to occur, a vesicular mode of walling off Lyp from the rest of the cell whilst containing it within the immediate vicinity where its action will be required would provide an aesthetically plausible mechanism negating the need for recruitment of Lyp from more distal cellular compartments. Further studies are required to elucidate how Lyp forms these huge and dense clusters in order to understand how its function is regulated. It will be interesting to dissect exactly how these clusters are gated, to understand how the release of Lyp from these clusters occurs.

The imaging of T cells from genotyped individuals revealed that differences between the Lyp-R620 and Lyp-W620 only became apparent when T cells migrated on ICAM-1. The large clusters observed in PLL conditions seemed, to our surprise, unaffected. This indicated that the binding mutation within the first polyproline domain was dispensable for steady state clustering. To further test the requirements for Lyp clustering under PLL conditions, truncation mutants that can be imaged and tested for clustering will be of great value. When cells migrated, the large clusters appeared to

de-cluster for both Lyp-W620 and Lyp-W620, but in the case of Lyp-R620, this led to the detection of more monomers not participating in clusters. Based on my signalling studies the presence of monomers is associated with a state when Lyp interacts with its substrates (Chapter 5). Interestingly, the clusters that were present in the migrating T cells displayed no significant differences in size, composition or number (Figure 6.10-6.12). These results argue that both under PLL and ICAM-1 conditions, clustering was intact. Instead of clustering perturbations, it appeared as though there was an inability of Lyp, once released from a cluster, to localise at the membrane. This result was surprising, and further studies are needed to understand the positional significance of Lyp at or near the membrane. To this end, co-localisation studies that can correlate positional information with regard to Lyp and its substrates will be key in understanding how the cluster dynamics of Lyp may regulate its ability to target and interact with its substrates.

One finding during this project was the slow speeds at which the Lyp-W620 cells migrated on ICAM-1 under static conditions, as compared to the Lyp-W620. This finding was not in line with 1) knockdown experiments demonstrating that reducing total Lyp protein by 50% increases speeds of migration 2) the inability of the Lyp-W620 to decrease speeds when over-expressed in T cells 3) increased signalling in the Lyp-W620 carriers, and 4) the increased migration of Lyp-W620 expressing T cells under flow. To reconcile these differences, LFA-1 stains were performed on migrating T cells expressing Lyp-R620 or Lyp-W620 T cells. LFA-1 clustering is an important step in the maturation of LFA-1 into firm adhesion complexes (Alon, Aker et al. 2003, Kim, Carman et al. 2004). Clustering might therefore be thought of as a correlate of signal strength. If it is the case that Lyp-W620 is a loss of function variant, LFA-1 clustering at the cell

surface of migrating T cells would be increased. In migratory conditions, this increase might then lead to slower speeds of migration due to increases in adhesion not allowing the cell membrane to move appropriately in response to force generation by the cytoskeleton. This effect may have been missed due to inefficient knockdowns and the overexpression of Lyp-W620 on a Lyp-R620 background. Indeed, I was able to show that clustering of LFA-1 in T cells from Lyp-W620 individuals was over twice that of Lyp-R620 expressing T cells. These results might suggest that LFA-1 signalling and function is not regulated in T cells from Lyp-W620 donors in the same way as Lyp-R620, and that this effect may be due to signalling differences that result from having a mutation within the binding domain of Lyp leading to more LFA-1 clustering. In a more physiologically relevant setup, taking a shear flow approach to measure the ability of cells to adhere to ICAM-1 under conditions that mimic blood flow, indicated that in this context, the Lyp-W620 donors were indeed more able to adhere to ICAM-1, consolidating our LFA-1 clustering results.

The super-resolution data was therefore completely in line with our previous findings, suggesting that Lyp-W620 is deficient in its ability to regulate signalling through LFA-1 because of defective positioning at the membrane, leading to functional and biochemical disturbances once LFA-1 is engaged. The imaging data, and particularly the inverse relationship that appears to exist between Lyp monomers at the membrane and LFA-1 clustering dynamics, point toward Lyp-W620 being a loss-of-function mutation.

Chapter 7 Concluding Discussion

7.1 Lyp regulates multiple signalling pathways including LFA-1

Here we present evidence that Lyp in humans, and the orthologue PEP in mice, is an integrin signalling intermediate. Lyp was originally identified as interacting with membrane proximal TCR signalling proteins and so subsequently many studies chose to focus on the role of this phosphatase in antigen receptor signalling. It has, however, become increasingly evident in recent years, that in fact Lyp may function downstream of many different receptors, indicating a more universal role in immune cell signal transduction than previously appreciated (Zhang, Zahir et al. 2011, Spalinger, Lang et al. 2013, Spalinger, Lang et al. 2013, Wang, Shaked et al. 2013, Maine, Marquardt et al. 2014).

Functional studies of Lyp in primary T cells migrating on ICAM-1 demonstrated that partly silencing Lyp gene expression can lead to increased speeds of migration and that, conversely, overexpression of the phosphatase inhibits the speeds at which cells migrate. The decreases in speeds observed appeared to be dependent on the catalytic activity of Lyp. Furthermore, genotyped T cells carrying the autoimmune disease associated Lyp variant also displayed altered speeds of migration. These functional studies, and many more that are currently in progress, set the stage for this project, and pointed to Lyp being a negative regulator of integrin signalling.

7.2 How does Lyp, Csk and PAG regulate signalling pathways?

Precisely how Lyp regulates signalling pathways, apart from its obvious ability to dephosphorylate very specific tyrosine residues on substrates such as Lck and ZAP-70, remains somewhat obscure. Another negative regulator of receptor signalling – the kinase Csk – has been shown to form a complex with Lyp (Cloutier and Veillette 1999). The complexing of these two signalling intermediates remains enigmatic, although the direct association is thought to be perturbed by the Lyp-R620W variant; does the complex potentiate the ability of Lyp to dephosphorylate its substrates? Does the complex allow for more efficient substrate interactions? Is this complex inhibitory? Conflicting data within the literature indicates that no consensus has been reached, with specific respect to when Lyp and Csk complex, and what this might mean in terms of signal cascade regulation (Fiorillo, Orru et al. 2010, Vang, Liu et al. 2012, de la Puerta, Trinidad et al. 2013).

In resting and migrating cells, Lyp, Csk and PAG were co-localised, indicating that these signalling intermediates are either in close opposition to one another or possibly physically interacting. My experiments demonstrated that despite co-localisation of Lyp-Csk-PAG in both resting and migrating cells, complexing of Lyp and Csk is notably increased after receptor stimulation, as demonstrated by co-immunoprecipitation (Chapter 3), indicating that in resting cells, Lyp and Csk may be less physically associated. The increase of Csk-Lyp complexing was also associated with the dissociation of both Csk and Lyp from PAG, raising the interesting possibility that the function of this trimeric complex may be two fold and may differentially associate

under specific signalling conditions. What this implies is that the Lyp-Csk-PAG complex probably functions in both resting and signalling cells but the way in which it regulates under these two conditions will be different. Rather unexpectedly, it appears as though during an active signal, PAG plays less of a role in recruiting Lyp to the membrane than in resting cells.

Perhaps an explanation of how the Lyp-Csk-PAG complex is operating can be gleaned from the super resolution data (Chapter 6). When investigating the biology of Lyp using super resolution techniques, the staining patterns of Lyp in fixed and live resting cells, where large mobile clusters were observed, was inconsistent with the staining patterns of Csk, which in no way resembled Lyp staining (data not shown). Unfortunately, it was not possible to optimise the super resolution staining's sufficiently to accommodate dual color imaging such that the results for both Lyp and Csk were robust enough for an analysis (eg too few localisations in one channel). However, independent stains for Csk alone strongly suggested that this kinase is unlikely to exist within the large Lyp clusters at a high stoichiometry; this would be completely in line with the biochemical findings. Dual color Csk and Lyp imaging will help to clarify this issue. Furthermore, in migrating cells, the large clusters appeared to de-cluster. I hypothesise that it is only after Lyp is released from the large clusters, when T cells migrate, that Lyp and Csk can then interact to form a complex. This interpretation may be compromised by the imaging modality used, however, because TIRF microscopy records events at the membrane only, and there may be important interactions between Lyp and Csk deeper within the cytoplasm, away from the membrane; this is in contrast to co-immunoprecipitation experiments which detect complex dynamics from whole cell lysates without any compartmental information

whatsoever. It is of course possible to fractionate lysates and then immunoprecipitate from cellular fractions, which in the future may be an interesting approach. Live cell imaging is, however, the preferential modality to truly observe the signalling dynamic.

In addition, the biochemical data pointed to Csk dissociating from PAG, which in turn led to increases in pY505-Lck, presumably because of exclusion of Csk from lipid rafts, the microdomains rich in Lck, or the attenuation of Csk catalysis. The dissociation of PAG from Csk was reminiscent of the TCR pathway, where it has been demonstrated that these two molecules dissociate following TCR engagement (Torgersen, Vang et al. 2001, Davidson, Bakinowski et al. 2003). If Csk can no longer position at the membrane via PAG it would be expected that a larger proportion would be cytoplasmic in migrating cells, although it is currently unclear which cellular compartment Csk is displaced to. The complexing of Lyp and Csk appears to occur when the integrin is actively signalling. These findings strongly suggest that pools of Csk and Lyp at the membrane of resting T cells are less associated, and that association is correlated with the declustering of Lyp following receptor stimulation; here, Lyp becomes more available for association with Csk. Interestingly, the declustering of Lyp was also observed in the context of an anti-CD3 stimulation which faithfully recapitulated the de-clustering seen when stimulating through integrins, with Lyp displaying even more declustering (data not shown). I propose a general mechanism whereby Lyp is regulated through its containment in large clusters at steady state. These large clusters appear to localise via the microtubule network. After stimulation, Csk partially leaves PAG rich domains and associates with de-clustered Lyp oligomers or monomers to generate a complex, the action of which remains to be studied. I do not know if the Lyp-Csk complex potentiates the individual phosphatase and kinase action of these

proteins. My preliminary experiments suggest that actually ZAP-70 and Vav are not complexed with Csk in migrating cells, but are complexed with Lyp, suggesting that the Lyp-Csk complex does not target these two signalling intermediates. The biology here is clearly very complex. Further studies will be required to understand the nature of Lyp clusters, including the possibility that Lyp may be in vesicles or held together by protein-protein interactions that may be hetero or homotypic, and how, after stimulation, the Csk/Lyp complex remains localised to the membrane proximal “TIRF” zone . A model describing how Csk, Lyp and PAG might regulate Lck is presented in figure 7.1.

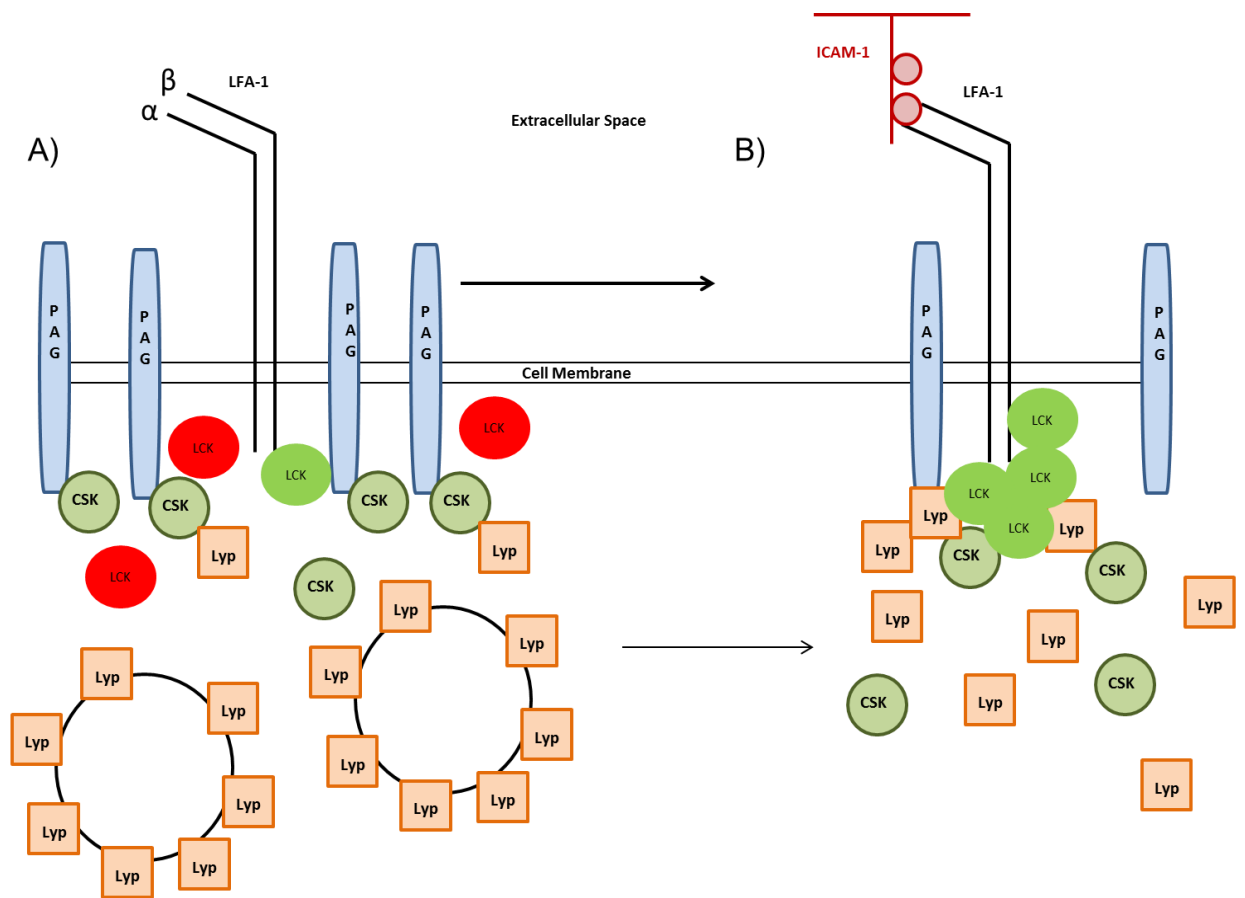

Figure 7.1. The Lyp-Csk-PAG complex regulates integrin outside-in signalling. A) in resting T cells, Csk and Lyp are associated with PAG, applying tonic negative signals on Lck (green=on, red=off). A pool of submembrane Lyp clusters is sequestered and positioned at the membrane, a process that may be microtubule dependent. When LFA-1 is not engaged by ICAM-1, the majority of Lyp is sequestered/packaged into clusters with some “free Lyp” at the membrane interacting with Csk. B) When integrins are engaged, PAG is dephosphorylated, leading to Csk and Lyp dissociation, allowing for local increases in Lck activity. Lyp is released from large clusters and regulates signalling independently of PAG but may be associated with Csk at the membrane which may in some way facilitate its localisation/substrate interaction. The way in which Lyp, Csk and

PAG regulate signalling in resting cells versus cells signalling through integrin is quantitatively and possibly qualitatively different.

7.3 Lyp declusters to target its substrates

In support of the inhibitory function of these large Lyp clusters at the membrane of resting T cells, is the finding that Lyp appeared to be highly associated with signalling intermediates only when T cells migrate. These results, when taken together, further suggest that the declustering of Lyp promotes interactions with phosphorylated substrates. One question often arising from these findings is why would a negative regulator be so active during the signalling event, it is a negative regulator, surely it should be “off” during an active signal? The answer to this question lies in the nature of regulation required in any given signalling context. Cell migration is a highly dynamic process, and so one might predict that signals directing such a process would mirror the physical process itself; thus, signals should also be dynamic. Collectively, protrusion, contraction and receptor engagement govern cellular locomotion according to an oversimplified model. In any given locale within a cell, signalling intermediates might require rapid cycles of turning on or off, depending on the requirement of that locale to protrude, or to contract, or to remain stationary. Thus, whilst in migrating T cells net changes in phosphorylation occur, as demonstrated by western blotting of whole cell lysates, kinases and phosphatase are, in reality, in a dynamic equilibrium under resting conditions. This steady state then shifts under conditions of receptor engagement leading to spikes of phosphorylation in certain sub-cellular compartments.

Although I have not been able to demonstrate experimentally the extent of dynamic phosphorylation events occurring in our experimental systems when T cells migrate, it

is very unlikely that a subset of kinases turns on through phosphorylation and then this same subset stays on until the cells stop migrating. Instead, different pools of the same signalling intermediate will be activated and inactivated forming complex feedback loops governed in part at least by receptors, kinases and phosphatases that in turn control specific cellular activity (Nika, Soldani et al. 2010, Schoenborn, Tan et al. 2011). Based on the available data, I propose that Lyp plays an important role in regulating the spatio-temporal activity of kinases, leading to changes in the tempo of signal transduction when absent, and shifting the dynamic equilibrium to a more “on” state during an active signal. Extending this idea into other signal transduction pathways, phospho- activity at the synapse of a T cell-APC conjugate has been shown to be sustained for hours, perhaps even days, and so this idea of regulating active signal ensuring it does not go unchecked could also hold true in the context of T cell receptor signalling, as well as many other signalling events (Huppa, Gleimer et al. 2003). It should also be said that the relative contribution of Lyp regulating steady state signal dynamics or indeed signal shutdown was not investigated in this project and may represent another important function of Lyp. Acutely inhibit-able Lyp constructs would be of great benefit to study the importance of Lyp in non-signalling cells, or perhaps a biosensor allowing phosphatase activity to be monitored. It would be interesting to monitor phosphorylation on Lyp substrates when Lyp is acutely inhibited, in the absence of receptor stimulation. One caveat associated with studying steady state regulation of a signalling is that of the real potential to generate artefact, because in vivo, cells are never rested or starved, and instead are constantly intercepting hundreds if not thousands of signals at a time. This was much food for thought, and plagued me throughout my PhD. To rest or not to rest, I now realise it depends on the question.

7.4 How is signal specificity achieved through the usage of similar signalling intermediates by different receptors?

The question of signal specificity and cellular programming emerges not only from these studies, but from many others that have investigated pathways utilising TCR signalling intermediates (Stephens, Romer et al. 1995, Petricoin, Ito et al. 1997, Micouin, Wietzerbin et al. 2000, Ticchioni, Charvet et al. 2002, Kremer, Humphreys et al. 2003, Ahmed, Beeton et al. 2005, Kumar, Humphreys et al. 2006). How are the same signalling intermediates utilised by different receptors, leading to what appears to be a completely disparate response? Why do some receptors appear to heterodimerise? Some have tried to explain these differences by postulating that certain protein functions are evoked in response to receptor engagement through specific post-translational modification. For example, three studies (Cimo, Ahmed et al. 2013, Lek, Morrison et al. 2013, Jenkins, Stinchcombe et al. 2014) have recently demonstrated that 1) inhibition of ZAP-70 catalytic activity does not impair adhesion and migration or the initial stages of synapse formation and 2) the catalytic loop of ZAP-70 is not phosphorylated in response to integrin ligation, and instead, it appears as though Y319 is specifically phosphorylated, and probably plays a role in recruiting PLC γ . Contrary to these studies, I found that ZAP-70 was phosphorylated at tyrosine 493 which is associated with upregulation of catalytic activity. Unpublished data from the Hogg lab are in good agreement with my results (personal communication with Rachel Evans).

My results, and those of others, suggest that pY493 is phosphorylated, but whether or not this phosphorylation is necessary for integrin signal transduction was not examined here or in the other studies performed. Perhaps the inhibitors used in the

aforementioned study allowed for enough residual catalytic activity allowing the signal to proceed. Another explanation might be that in the absence of ZAP-70 pY493 phosphorylation, another protein can compensate for ZAP-70 catalytic activity. The finding by Ladbury et al of no phosphorylation of pY493 on ZAP-70 in response to integrin ligation might be explained by their experimental setup in which they were running lysates from TCR stimulations directly next to integrin stimulations. A TCR stimulation might lead to a greater amount of pY493-ZAP-70 which might develop on a blot faster than integrin stimulations, masking any phosphorylation in the integrin stimulation lanes. In addition, from personal experience, these antibodies can be difficult to use. One easy experiment that the Ladbury group did not perform was an evaluation of ZAP-70 phosphorylation by immunoprecipitation to ensure that the pY493 ZAP-70 antibody had large amounts of protein to bind to increasing the chances of detection of phosphorylation. It remains to be confirmed if this activity is actually required, and bearing in mind that adhesion and migration are not the only processes governed by integrin outside-in signals, other outcomes like certain T cell effector functions might need to be tested to fully resolve this issue.

In considering how outside-in signalling proceeds following integrin engagement, I investigated the relationship between Csk and PAG. These experiments were inspired by recent work by Weiss and colleagues who demonstrated that by specifically inhibiting Csk in an acute setting, in the absence of a receptor stimulation, a signal cascade is initiated that resembles that of the TCR (and integrin) engagement (Schoenborn, Tan et al. 2011, Tan, Manz et al. 2014). What these studies really hint at is the idea that signalling pathways must be actively restrained in order to avoid harmful, uncontrolled activity, and that some of the initial events governing

signal initiation might involve the removal of negative regulators rather than the activation of inactive pools of signalling components associated with positive signals. Here, I find that PAG is dephosphorylated, and that Csk partially dissociated from PAG when it was in its dephosphorylated state. Importantly, I never detected complete dephosphorylation of PAG, suggesting a that pool of Csk was PAG associated and most likely regulating signals albeit not in a resting cell context. FRET studies investigating Src-Csk interactions in migrating cells have identified Src-Csk interactions in cellular protrusions, indicating an active role for the complex even in migrating cells (Vielreicher, Harms et al. 2007). However, the decrease in Csk-PAG association is correlated with decreases in Lck phosphorylation at the inhibitory site targeted by the Csk-PAG complex, suggesting that the overall conformational requirements of Lck in migrating cells is different and may be an intrinsic part of the migratory programme. Other than ZAP-70, the targets of Lck downstream of integrin signalling have not yet been thoroughly investigated, although preliminary data from our lab suggest that Lck rather than ZAP-70 directly targets Vav, which would be in keeping with reports of Vav activation by Ladbury, who used both Lck and ZAP-70 deficient Jurkats to demonstrate that Lck and not ZAP-70 is required for Vav phosphorylation. My opinion is that in order to understand the differences in the way in which signalling intermediates are shared amongst pathways will be through systematic investigation of post translational modifications and imaging of signalling hubs by way of super resolution techniques, as it most likely will be both post translational modifications and protein localisation (and indeed modification on other proteins) that might dictate downstream effectors, leading to specific responses. The null hypothesis here would be that there are no differences in signalling intermediate behaviour regardless of the receptor used to

evoke its activation. Perhaps it is the co-ligation of other receptors in parallel that might lead to specific responses if this is this case.

7.5 Signalling through LFA-1

Co-immunoprecipitation experiments suggested that Lck and ZAP-70 were recruited to LFA-1 in migrating cells. One question is whether these intermediates are acting in the immediate vicinity of LFA-1 or are activated at LFA-1 and then move to other cellular compartments in order to fulfil their function. Src family kinases have been shown to bind to integrin via their SH3 domain, which is conserved across all Src family kinases (Arias-Salgado, Lizano et al. 2003). This has not formally been demonstrated in T cells for Lck and LFA-1, but cross checking bioinformatics resources has revealed the presence of conserved residues in various integrin β family subunits, making it highly likely that Lck and LFA-1 interact via these conserved motifs. Perhaps more puzzling is the recruitment of ZAP-70. No ITAM motifs exist within the integrin chains that can recruit ZAP-70. In myeloid cells and neutrophils it has been shown that Syk, which has virtually identical domain organisation to ZAP-70, binds to ITAM containing adaptor proteins, and deletion of these adaptor proteins leads to disruption of outside-in signalling. Curiously, these adaptor proteins have never been demonstrated to bind integrin directly. This can be interpreted in two ways: 1) The adaptor proteins may have very weak association with integrin and cannot be co-immunoprecipitated; 2) Syk is activated at the integrin tail and then binds to adaptor proteins subsequently. The extent to which Syk can be co-immunoprecipitated might indicate that the adaptor-Syk complex is not physically associated with integrin, and that Syk binding to integrin or

other integrin associated proteins precedes its association with adaptors. It is hard to imagine why adaptor proteins that anchor ZAP-70 directly to integrin might be lost in a co-immunoprecipitation (even with tagged adaptor proteins and therefore good antibodies) whilst ZAP-70 interaction via the same adaptor to which it is bound is not. There must exist a hierarchy of association, where the inability to detect certain proteins will be predicated on the detection of another binding partner. Whether an ITAM containing protein in T cells recruits ZAP-70 requires clarifying. Clearly, many more studies are needed to understand how ZAP-70 is recruited to LFA-1 and why it is recruited to LFA-1.

In migrating cells, Vav dissociated from LFA-1. This was a somewhat surprising result. However, others have reported a similar relationship between other integrins and vav (Garcia-Bernal, Parmo-Cabanas et al. 2009). One very curious finding that accompanied this observation was the difference in total Vav detected in Triton-x100 detergent when assaying migrating cells and cells on PLL. Vav clearly moved between the detergent soluble and the detergent insoluble fractions. This might suggest that Vav, in non-migrating cells, is enriched in a lipid compartment that is inaccessible to Triton, and that when cells migrated, much more Vav can be detected, suggesting that Triton was in these conditions able to solubilise Vav. This was an intriguing observation that might be interesting to follow up by using different detergents for biochemistry and imaging studies to understand how this difference in compartmentalisation might allow Vav to function under various signalling conditions.

Studies have indicated that in resting cells Vav and talin form a complex (Garcia-Bernal, Parmo-Cabanas et al. 2009). A situation can be envisaged where Vav and talin are directly associated with LFA-1 in resting cells, this might position the complex such that

when a signal is intercepted, Vav and talin dissociate and talin, already being in close proximity to the integrin, can bind motifs in the cytoplasmic region stabilising the high affinity integrin and allow strong adhesive contacts to be made with target cells expressing ICAM-1 in nano- instead of microseconds, which may be particularly important in the vasculature. The importance of Vav in migration has been underscored in many studies(Fernandez-Espartero, Ramel et al. 2013, Tong, Zhao et al. 2013). In fact, Vav plays a central role in various receptor signalling events because of its ability to instruct the cytoskeleton through Rho GTPases, thereby allowing remodelling of cytoplasmic components that are associated with signalling. The cytoskeleton, in addition to its appreciable role in motility and cell shape, has in more recent years become a topic of considerable interest for immunologists through studies suggesting that disruption of the cytoskeleton can elicit antigen receptor signalling, and conversely, stabilisation of it can inhibit signalling(Treanor, Depoil et al. 2010, Tan, Manz et al. 2014). Understanding how Vav responds to integrin signals and subsequently instructs Rho and Rac GTPases associated with cytoskeletal remodelling will be key to understanding how cytoskeletal changes drive migration(Ridley 2011).

Given the predication that Lyp may actively regulate the dynamic phosphorylation of signalling intermediates like Lck, ZAP-70 and Vav, it was perhaps not surprising to find Lyp more associated with integrin when T cells migrated on ICAM-1. In addition, Csk was also found to be more associated with LFA-1 in migrating cells. Thus, I conclude that negative regulation is an important facet of active signal regulation.

7.6 The consequences of a single nucleotide polymorphism within a binding domain of Lyp

One achievement of this project was the use of super-resolution to try and understand how a single nucleotide polymorphism might alter Lyp behaviour at the membrane. These experiments demonstrated consistent differences in the localisation of the R620-Lyp versus the R620W-Lyp, which manifested only during active signalling (figure 7.2). In addition, it was possible to image LFA-1 in genotyped donors, and I demonstrated greatly increased integrin clustering in individuals harbouring R620W-Lyp. These data greatly consolidated functional and signalling experiments that indicated the disease associated variant is in fact loss-of-function, at least in the context of integrin signalling.

Why Lyp is unable to station at the membrane correctly in migrating T cells is an open question. One known consequence of the W620-Lyp is the inability of this Lyp variant to associate with Csk. It may be that as a result of the disruption between Lyp and Csk, Lyp cannot localise properly at the membrane of migrating T cells. On the other hand, it may be through the inability of Lyp to interact with other proteins via its binding domain that might lead to differences in localisation at the membrane. An experiment that will help resolved whether or not Csk is involved in stationing Lyp at the membrane in migrating cells might involve the use of Csk knockout T cells to address this question. It would be of interest to see whether Csk knockout cells phenocopy the Lyp mutation. If this turns out to be the case, it would provide some evidence demonstrating that it is as a result of Lyp's inability to couple with Csk that localisation is compromised.

Finally, it might be interesting to consider the consequence of Lyp participating in multiple pathways in the context of the Lyp mutation. T cell receptor signalling is a known inside-out signal for integrins leading to more intermediate affinity LFA-1 at the surface of T cells that can bind to integrin. If the mutation leads to augmented signalling through the TCR, more LFA-1 will be activated and following the binding of ICAM-1, the signal will be amplified as Lyp will be participating downstream of integrin signalling as well. Thus Lyp could be acting downstream of a series of signal transduction events, dysregulating multiple pathways with overlapping features that are initiated in a step-wise fashion. This in turn might contribute to the dysregulation of immune responses which may influence susceptibility to autoimmune disease.

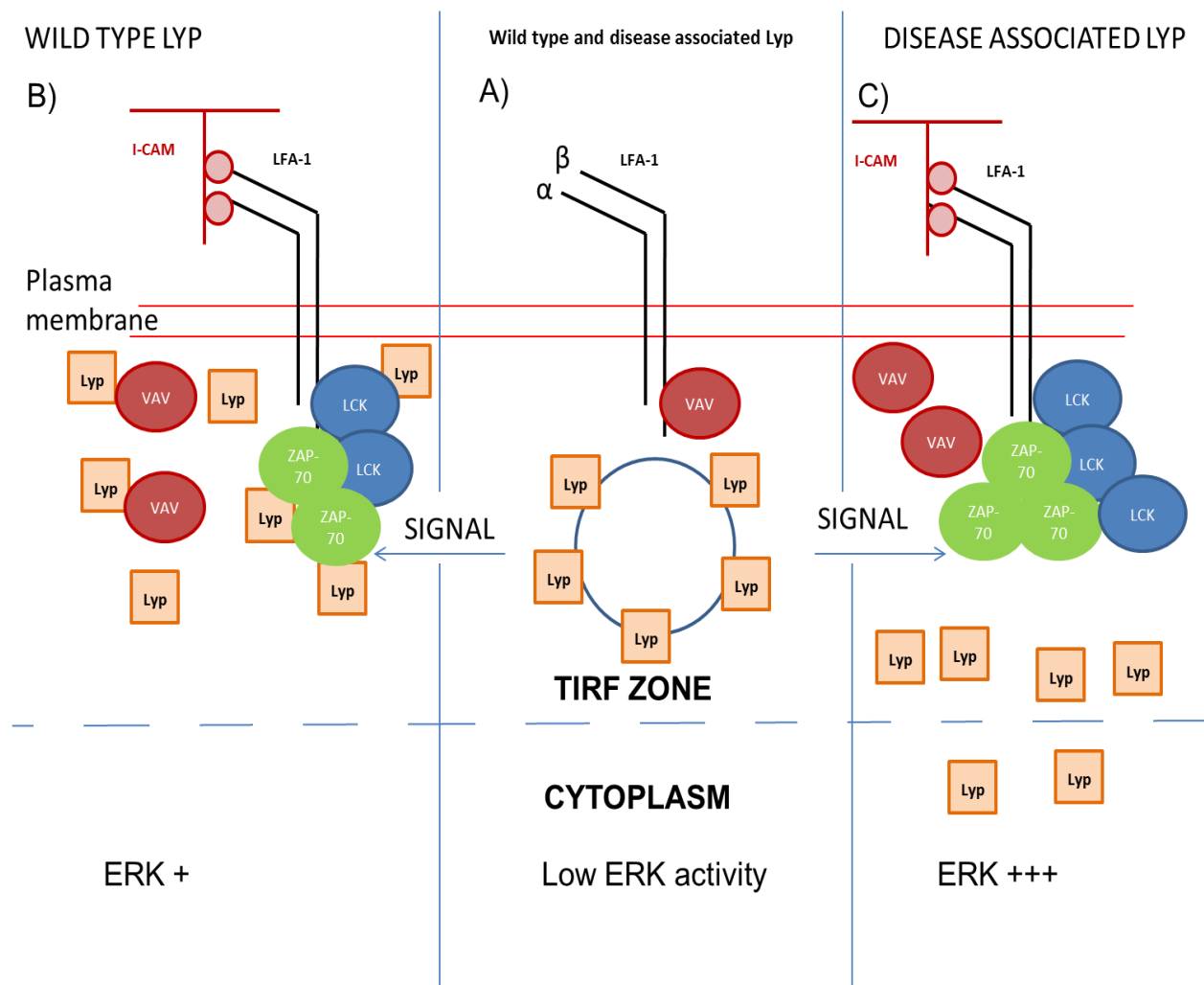

Figure 7.2 Disease associated Lyp fails to regulate outside-in signalling through LFA-1.

A) In resting T cells, Lyp is found in large submembranous clusters which can be detected in the TIRF zone. The formation of these clusters is independent of the binding domain mutation in Lyp that predisposes to autoimmune disease. B) In the absence of a mutation in the binding domain, Lyp is released from large clusters and is retained (half life of retainment unknown) at the membrane to regulate signalling intermediates recruited to LFA-1 when it is engaged, including Lck and ZAP-70. Vav on the other hand, is released from LFA-1 following ICAM-1 engagement and may be

regulated by Lyp in a different cellular compartment away, or in close proximity to LFA-1. Following integrin engagement, ERK is phosphorylated. C) If a mutation is present in the binding domain of Lyp, it cannot localise properly at the membrane, leading to increased signalling. In this context, ERK phosphorylation is increased, as is integrin clustering. One reason for this inability of Lyp-W620 to station at the membrane may be due to its inability to complex properly with Csk.

Concluding remarks

Here I identify Lyp as being a negative regulator LFA-1 outside-in. In addition, using T cells from human individuals who have been genotyped for the W620-Lyp variant, I show that this polymorphism differentially regulates signalling, and appears to be unable to regulate integrin signalling in the same way as the common variant, which may in part be responsible for the susceptibility to autoimmune disease displayed by those harbouring the W620-Lyp variant. The evidence collected in this project points toward the W620-Lyp variant as being loss-of-function, leading to increased signalling when LFA-1 is engaged, and, as a consequence, increased LFA-1 clustering.

These studies might indicate that other LFA-1 dependent T cell functions will be regulated by Lyp. This could include formation of the immunological synapse and T cell effector functions.

REFERENCES

- Aarnisalo, J., A. Treszl, P. Svec, J. Marttila, V. Oling, O. Simell, M. Knip, A. Korner, L. Madacsy, B. Vasarhelyi, J. Ilonen and R. Hermann (2008). "Reduced CD4+T cell activation in children with type 1 diabetes carrying the PTPN22/Lyp 620Trp variant." J Autoimmun **31**(1): 13-21.
- Abram, C. L. and C. A. Lowell (2007). "Convergence of immunoreceptor and integrin signaling." Immunol Rev **218**: 29-44.
- Abtahian, F., N. Bezman, R. Clemens, E. Sebzda, L. Cheng, S. J. Shattil, M. L. Kahn and G. A. Koretzky (2006). "Evidence for the requirement of ITAM domains but not SLP-76/Gads interaction for integrin signaling in hematopoietic cells." Mol Cell Biol **26**(18): 6936-6949.
- Ahmed, Z., C. A. Beeton, M. A. Williams, D. Clements, C. T. Baldari and J. E. Ladbury (2005). "Distinct spatial and temporal distribution of ZAP70 and Lck following stimulation of interferon and T-cell receptors." J Mol Biol **353**(5): 1001-1010.
- Alon, R., M. Aker, S. Feigelson, M. Sokolovsky-Eisenberg, D. E. Staunton, G. Cinamon, V. Grabovsky, R. Shamri and A. Etzioni (2003). "A novel genetic leukocyte adhesion deficiency in subsecond triggering of integrin avidity by endothelial chemokines results in impaired leukocyte arrest on vascular endothelium under shear flow." Blood **101**(11): 4437-4445.
- Alon, R. and M. L. Dustin (2007). "Force as a facilitator of integrin conformational changes during leukocyte arrest on blood vessels and antigen-presenting cells." Immunity **26**(1): 17-27.
- Amrein, K. E., J. Molnos, J. D. zur Hausen, N. Flint, B. Takacs and P. Burn (1998). "Csk-mediated phosphorylation of substrates is regulated by substrate tyrosine phosphorylation." Farmacology **53**(4): 266-272.
- Arechiga, A. F., T. Habib, Y. He, X. Zhang, Z. Y. Zhang, A. Funk and J. H. Buckner (2009). "Cutting edge: the PTPN22 allelic variant associated with autoimmunity impairs B cell signaling." J Immunol **182**(6): 3343-3347.

Arias-Salgado, E. G., S. Lizano, S. Sarkar, J. S. Brugge, M. H. Ginsberg and S. J. Shattil (2003). "Src kinase activation by direct interaction with the integrin beta cytoplasmic domain." Proc Natl Acad Sci U S A **100**(23): 13298-13302.

Arimura, Y. and J. Yagi (2010). "Comprehensive expression profiles of genes for protein tyrosine phosphatases in immune cells." Sci Signal **3**(137): rs1.

Atkins, W. M. (2014). "Biological messiness vs. biological genius: Mechanistic aspects and roles of protein promiscuity." J Steroid Biochem Mol Biol.

Axelrod, D. (1981). "Cell-substrate contacts illuminated by total internal reflection fluorescence." J Cell Biol **89**(1): 141-145.

Begovich, A. B., V. E. Carlton, L. A. Honigberg, S. J. Schrodi, A. P. Chokkalingam, H. C. Alexander, K. G. Ardlie, Q. Huang, A. M. Smith, J. M. Spoerke, M. T. Conn, M. Chang, S. Y. Chang, R. K. Saiki, J. J. Catanese, D. U. Leong, V. E. Garcia, L. B. McAllister, D. A. Jeffery, A. T. Lee, F. Batliwalla, E. Remmers, L. A. Criswell, M. F. Seldin, D. L. Kastner, C. I. Amos, J. J. Sninsky and P. K. Gregersen (2004). "A missense single-nucleotide polymorphism in a gene encoding a protein tyrosine phosphatase (PTPN22) is associated with rheumatoid arthritis." Am J Hum Genet **75**(2): 330-337.

Bergman, M., T. Mustelin, C. Oetken, J. Partanen, N. A. Flint, K. E. Amrein, M. Autero, P. Burn and K. Alitalo (1992). "The human p50csk tyrosine kinase phosphorylates p56lck at Tyr-505 and down regulates its catalytic activity." Embo j **11**(8): 2919-2924.

Bergmeier, W., T. Goerge, H. W. Wang, J. R. Crittenden, A. C. Baldwin, S. M. Cifuni, D. E. Housman, A. M. Graybiel and D. D. Wagner (2007). "Mice lacking the signaling molecule CalDAG-GEFI represent a model for leukocyte adhesion deficiency type III." J Clin Invest **117**(6): 1699-1707.

Bezman, N. A., L. Lian, C. S. Abrams, L. F. Brass, M. L. Kahn, M. S. Jordan and G. A. Koretzky (2008). "Requirements of SLP76 tyrosines in ITAM and integrin receptor signaling and in platelet function in vivo." J Exp Med **205**(8): 1775-1788.

Bivona, T. G., H. H. Wiener, I. M. Ahearn, J. Silletti, V. K. Chiu and M. R. Philips (2004). "Rap1 up-regulation and activation on plasma membrane regulates T cell adhesion." J Cell Biol **164**(3): 461-470.

Bolomini-Vittori, M., A. Montresor, C. Giagulli, D. Staunton, B. Rossi, M. Martinello, G. Constantin and C. Laudanna (2009). "Regulation of conformer-specific activation of the integrin LFA-1 by a chemokine-triggered Rho signaling module." Nat Immunol **10**(2): 185-194.

Bottini, N., L. Musumeci, A. Alonso, S. Rahmouni, K. Nika, M. Rostamkhani, J. MacMurray, G. F. Meloni, P. Lucarelli, M. Pellecchia, G. S. Eisenbarth, D. Comings and T. Mustelin (2004). "A functional variant of lymphoid tyrosine phosphatase is associated with type I diabetes." Nat Genet **36**(4): 337-338.

Brand, O., S. Gough and J. Heward (2005). "HLA , CTLA-4 and PTPN22 : the shared genetic master-key to autoimmunity?" Expert Rev Mol Med **7**(23): 1-15.

Bravo, M. J., J. D. Colmenero, M. I. Queipo-Ortuno, P. Morata, G. Orozco, J. Martin, A. Alonso and A. Caballero (2009). "PTPN22 C1858T polymorphism and human brucellosis." Scand J Infect Dis **41**(2): 109-112.

Brown, A. C., I. M. Dobbie, J. M. Alakoskela, I. Davis and D. M. Davis (2012). "Super-resolution imaging of remodeled synaptic actin reveals different synergies between NK cell receptors and integrins." Blood **120**(18): 3729-3740.

Butcher, E. C. (1991). "Leukocyte-endothelial cell recognition: three (or more) steps to specificity and diversity." Cell **67**(6): 1033-1036.

Canault, M., D. Ghalloussi, C. Grosdidier, M. Guinier, C. Perret, N. Chelghoum, M. Germain, H. Raslova, F. Peiretti, P. E. Morange, N. Saut, X. Pillois, A. T. Nurden, F. Cambien, A. Pierres, T. K. van den Berg, T. W. Kuijpers, M. C. Alessi and D. A. Tregouet (2014). "Human CalDAG-GEFI gene (RASGRP2) mutation affects platelet function and causes severe bleeding." J Exp Med **211**(7): 1349-1362.

Canton, I., S. Akhtar, N. G. Gavalas, D. J. Gawkrödger, A. Blomhoff, P. F. Watson, A. P. Weetman and E. H. Kemp (2005). "A single-nucleotide polymorphism in the gene encoding

lymphoid protein tyrosine phosphatase (PTPN22) confers susceptibility to generalised vitiligo."

Genes Immun **6**(7): 584-587.

Chabchoub, G., E. P. Teixeira, A. Maalej, M. Ben Hamad, Z. Bahloul, F. Cornelis and H. Ayadi (2009). "The R620W polymorphism of the protein tyrosine phosphatase 22 gene in autoimmune thyroid diseases and rheumatoid arthritis in the Tunisian population." Ann Hum Biol **36**(3): 342-349.

Chapman, S. J., C. C. Khor, F. O. Vannberg, N. A. Maskell, C. W. Davies, E. L. Hedley, S. Segal, C. E. Moore, K. Knox, N. P. Day, S. H. Gillespie, D. W. Crook, R. J. Davies and A. V. Hill (2006). "PTPN22 and invasive bacterial disease." Nat Genet **38**(5): 499-500.

Cherry, L. K., X. Li, P. Schwab, B. Lim and L. B. Klickstein (2004). "RhoH is required to maintain the integrin LFA-1 in a nonadhesive state on lymphocytes." Nat Immunol **5**(9): 961-967.

Cifuni, S. M., D. D. Wagner and W. Bergmeier (2008). "CalDAG-GEFI and protein kinase C represent alternative pathways leading to activation of integrin alphaIIb beta3 in platelets." Blood **112**(5): 1696-1703.

Cimo, A. M., Z. Ahmed, B. W. McIntyre, D. E. Lewis and J. E. Ladbury (2013). "CD25 and CD69 induction by alpha4beta1 outside-in signalling requires TCR early signalling complex proteins." Biochem J **454**(1): 109-121.

Cimo, A. M., Z. Ahmed, B. W. McIntyre, D. E. Lewis and J. E. Ladbury (2013). "CD25 and CD69 induction by $\alpha 4\beta 1$ outside-in signalling requires TCR early signalling complex proteins." Biochemical Journal **454**(1): 109-121.

Cinek, O., O. Hradsky, G. Ahmedov, A. Slavcev, S. Kolouskova, M. Kulich and Z. Sumnik (2007). "No independent role of the -1123 G>C and +2740 A>G variants in the association of PTPN22 with type 1 diabetes and juvenile idiopathic arthritis in two Caucasian populations." Diabetes Res Clin Pract **76**(2): 297-303.

Cloutier, J. F. and A. Veillette (1996). "Association of inhibitory tyrosine protein kinase p50csk with protein tyrosine phosphatase PEP in T cells and other hemopoietic cells." EMBO J **15**(18): 4909-4918.

Cloutier, J. F. and A. Veillette (1999). "Cooperative inhibition of T-cell antigen receptor signaling by a complex between a kinase and a phosphatase." J Exp Med **189**(1): 111-121.

Cohen, S., H. Dadi, E. Shaoul, N. Sharfe and C. M. Roifman (1999). "Cloning and characterization of a lymphoid-specific, inducible human protein tyrosine phosphatase, Lyp." Blood **93**(6): 2013-2024.

Cote, J. F., A. Charest, J. Wagner and M. L. Tremblay (1998). "Combination of gene targeting and substrate trapping to identify substrates of protein tyrosine phosphatases using PTP-PEST as a model." Biochemistry **37**(38): 13128-13137.

Coventry, A., L. M. Bull-Otterson, X. Liu, A. G. Clark, T. J. Maxwell, J. Crosby, J. E. Hixson, T. J. Rea, D. M. Muzny, L. R. Lewis, D. A. Wheeler, A. Sabo, C. Lusk, K. G. Weiss, H. Akbar, A. Cree, A. C. Hawes, I. Newsham, R. T. Varghese, D. Villasana, S. Gross, V. Joshi, J. Santibanez, M. Morgan, K. Chang, W. H. Iv, A. R. Templeton, E. Boerwinkle, R. Gibbs and C. F. Sing (2010). "Deep resequencing reveals excess rare recent variants consistent with explosive population growth." Nat Commun **1**(8): 131.

Crittenden, J. R., W. Bergmeier, Y. Zhang, C. L. Piffath, Y. Liang, D. D. Wagner, D. E. Housman and A. M. Graybiel (2004). "CalDAG-GEFI integrates signaling for platelet aggregation and thrombus formation." Nat Med **10**(9): 982-986.

Cyster, J. G. (2003). "Lymphoid organ development and cell migration." Immunol Rev **195**: 5-14.

Dai, X., R. G. James, T. Habib, S. Singh, S. Jackson, S. Khim, R. T. Moon, D. Liggitt, A. Wolf-Yadlin, J. H. Buckner and D. J. Rawlings (2013). "A disease-associated PTPN22 variant promotes systemic autoimmunity in murine models." J Clin Invest **123**(5): 2024-2036.

Davidson, D., M. Bakinowski, M. L. Thomas, V. Horejsi and A. Veillette (2003). "Phosphorylation-dependent regulation of T-cell activation by PAG/Cbp, a lipid raft-associated transmembrane adaptor." Mol Cell Biol **23**(6): 2017-2028.

de la Puerta, M. L., A. G. Trinidad, C. Rodriguez Mdel, J. M. de Pereda, M. Sanchez Crespo, Y. Bayon and A. Alonso (2013). "The autoimmunity risk variant LYP-W620 cooperates with CSK in the regulation of TCR signaling." PLoS One **8**(1): e54569.

de Virgilio, M., W. B. Kiosses and S. J. Shattil (2004). "Proximal, selective, and dynamic interactions between integrin α IIb β 3 and protein tyrosine kinases in living cells." J Cell Biol **165**(3): 305-311.

Diaz-Gallo, L., P. Gourh, J. Broen, C. Simeon, V. Fonollosa, N. Ortego-Centeno, S. Agarwal, M. Vonk, M. Coenen, G. Riemekasten, N. Hunzelmann, R. Hesselstrand, F. Tan, J. Reveille, S. Assassi, F. Garcia-Hernandez, P. Carreira, M. Camps, A. Fernandez-Nebro, P. G. de la Pena, T. Nearney, D. Hilda, M. Gonzalez-Gay, P. Airo, L. Beretta, R. Scorza, A. Herrick, J. Worthington, A. Pros, I. Gomez-Gracia, L. Trapiella, G. Espinosa, I. Castellvi, T. Witte, F. de Keyser, M. Vanthuyne, M. Mayes, T. Radstake, F. Arnett, J. Martin and B. Rueda (2010). "Analysis of the influence of PTPN22 gene polymorphisms in systemic sclerosis." Ann Rheum Dis.

Dib, K. (2000). "BETA 2 integrin signaling in leukocytes." Front Biosci **5**: D438-451.

Douroudis, K., E. Prans, K. Haller, V. Nemvalts, T. Rajasalu, V. Tillmann, K. Kisand and R. Uibo (2008). "Protein tyrosine phosphatase non-receptor type 22 gene variants at position 1858 are associated with type 1 and type 2 diabetes in Estonian population." Tissue Antigens **72**(5): 425-430.

Douroudis, K., A. Shcherbakova, H. Everaus and A. Aints (2010). "PTPN22 gene regulates natural killer cell proliferation during in vitro expansion." Tissue Antigens **76**(4): 315-318.

Dustin, M. L. (2009). "The cellular context of T cell signaling." Immunity **30**(4): 482-492.

Dustin, M. L., S. K. Bromley, Z. Kan, D. A. Peterson and E. R. Unanue (1997). "Antigen receptor engagement delivers a stop signal to migrating T lymphocytes." Proc Natl Acad Sci U S A **94**(8): 3909-3913.

Evangelista, V., Z. Pamuklar, A. Piccoli, S. Manarini, G. Dell'elba, R. Pecce, N. Martelli, L. Federico, M. Rojas, G. Berton, C. A. Lowell, L. Totani and S. S. Smyth (2007). "Src family kinases mediate neutrophil adhesion to adherent platelets." Blood **109**(6): 2461-2469.

Evans, R., A. C. Lellouch, L. Svensson, A. McDowall and N. Hogg (2011). "The integrin LFA-1 signals through ZAP-70 to regulate expression of high-affinity LFA-1 on T lymphocytes." Blood **117**(12): 3331-3342.

Evans, R., A. C. Lellouch, L. Svensson, A. McDowall and N. Hogg (2011). The integrin LFA-1 signals through ZAP-70 to regulate expression of high-affinity LFA-1 on T lymphocytes.

Evans, R., I. Patzak, L. Svensson, K. De Filippo, K. Jones, A. McDowall and N. Hogg (2009). "Integrins in immunity." J Cell Sci **122**(Pt 2): 215-225.

Fagerholm, S., T. J. Hilden and C. G. Gahmberg (2002). "Lck tyrosine kinase is important for activation of the CD11a/CD18-integrins in human T lymphocytes." Eur J Immunol **32**(6): 1670-1678.

Fedetz, M., F. Matesanz, A. Caro-Maldonado, Smirnov, II, V. N. Chvorostinka, T. A. Moiseenko and A. Alcina (2006). "The 1858T PTPN22 gene variant contributes to a genetic risk of type 1 diabetes in a Ukrainian population." Tissue Antigens **67**(5): 430-433.

Fernandez-Espartero, C. H., D. Ramel, M. Farago, M. Malartre, C. M. Luque, S. Limanovich, S. Katzav, G. Emery and M. D. Martin-Bermudo (2013). "GTP exchange factor Vav regulates guided cell migration by coupling guidance receptor signalling to local Rac activation." J Cell Sci **126**(Pt 10): 2285-2293.

Fiorillo, E., V. Orru, S. M. Stanford, Y. Liu, M. Salek, N. Rapini, A. D. Schenone, P. Saccucci, L. G. Delogu, F. Angelini, M. L. Manca Bitti, C. Schmedt, A. C. Chan, O. Acuto and N. Bottini (2010). "Autoimmune-associated PTPN22 R620W variation reduces phosphorylation of lymphoid phosphatase on an inhibitory tyrosine residue." J Biol Chem **285**(34): 26506-26518.

Flint, A. J., T. Tiganis, D. Barford and N. K. Tonks (1997). "Development of "substrate-trapping" mutants to identify physiological substrates of protein tyrosine phosphatases." Proc Natl Acad Sci U S A **94**(5): 1680-1685.

Flodstrom-Tullberg, M., Y. T. Bryceson, F. D. Shi, P. Hoglund and H. G. Ljunggren (2009). "Natural killer cells in human autoimmunity." Curr Opin Immunol **21**(6): 634-640.

Folling, J., M. Bossi, H. Bock, R. Medda, C. A. Wurm, B. Hein, S. Jakobs, C. Eggeling and S. W. Hell (2008). "Fluorescence nanoscopy by ground-state depletion and single-molecule return." Nat Methods **5**(11): 943-945.

Frommhold, D., I. Mannigel, J. Schymeinsky, A. Mocsai, J. Poeschl, B. Walzog and M. Sperandio (2007). "Spleen tyrosine kinase Syk is critical for sustained leukocyte adhesion during inflammation in vivo." BMC Immunol **8**: 31.

Gao, J., K. E. Zoller, M. H. Ginsberg, J. S. Brugge and S. J. Shattil (1997). "Regulation of the pp72syk protein tyrosine kinase by platelet integrin alpha IIb beta 3." Embo j **16**(21): 6414-6425.

Garcia-Bernal, D., M. Parmo-Cabanas, A. Dios-Esponera, R. Samaniego, P. d. I. O. D. Hernan and J. Teixido (2009). "Chemokine-induced Zap70 kinase-mediated dissociation of the Vav1-talin complex activates alpha4beta1 integrin for T cell adhesion." Immunity **31**(6): 953-964.

Garton, A. J., A. J. Flint and N. K. Tonks (1996). "Identification of p130(cas) as a substrate for the cytosolic protein tyrosine phosphatase PTP-PEST." Mol Cell Biol **16**(11): 6408-6418.

Ghandour, H., X. Cullere, A. Alvarez, F. W. Luscinskas and T. N. Mayadas (2007). "Essential role for Rap1 GTPase and its guanine exchange factor CalDAG-GEFI in LFA-1 but not VLA-4 integrin mediated human T-cell adhesion." Blood **110**(10): 3682-3690.

Ghose, R., A. Shekhtman, M. J. Goger, H. Ji and D. Cowburn (2001). "A novel, specific interaction involving the Csk SH3 domain and its natural ligand." Nat Struct Biol **8**(11): 998-1004.

Giagulli, C., L. Ottoboni, E. Cavegion, B. Rossi, C. Lowell, G. Constantin, C. Laudanna and G. Berton (2006). "The Src family kinases Hck and Fgr are dispensable for inside-out, chemoattractant-induced signaling regulating beta 2 integrin affinity and valency in neutrophils, but are required for beta 2 integrin-mediated outside-in signaling involved in sustained adhesion." J Immunol **177**(1): 604-611.

Ginsberg, M. H., A. Partridge and S. J. Shattil (2005). "Integrin regulation." Curr Opin Cell Biol **17**(5): 509-516.

Gjorloff-Wingren, A., M. Saxena, S. Han, X. Wang, A. Alonso, M. Renedo, P. Oh, S. Williams, J. Schnitzer and T. Mustelin (2000). "Subcellular localization of intracellular protein tyrosine phosphatases in T cells." Eur J Immunol **30**(8): 2412-2421.

Gjorloff-Wingren, A., M. Saxena, S. Williams, D. Hammi and T. Mustelin (1999). "Characterization of TCR-induced receptor-proximal signaling events negatively regulated by the protein tyrosine phosphatase PEP." Eur J Immunol **29**(12): 3845-3854.

Gomez, L. M., J. M. Anaya and J. Martin (2005). "Genetic influence of PTPN22 R620W polymorphism in tuberculosis." Hum Immunol **66**(12): 1242-1247.

Gregersen, P. K., H. S. Lee, F. Batliwalla and A. B. Begovich (2006). "PTPN22: setting thresholds for autoimmunity." Semin Immunol **18**(4): 214-223.

Gregersen, P. K. and L. M. Olsson (2009). "Recent advances in the genetics of autoimmune disease." Annu Rev Immunol **27**: 363-391.

Gregorieff, A., J. F. Cloutier and A. Veillette (1998). "Sequence requirements for association of protein-tyrosine phosphatase PEP with the Src homology 3 domain of inhibitory tyrosine protein kinase p50(csk)." J Biol Chem **273**(21): 13217-13222.

Guittard, G., A. Gerard, S. Dupuis-Coronas, H. Tronchere, E. Mortier, C. Favre, D. Olive, P. Zimmermann, B. Payrastre and J. A. Nunes (2009). "Cutting edge: Dok-1 and Dok-2 adaptor molecules are regulated by phosphatidylinositol 5-phosphate production in T cells." J Immunol **182**(7): 3974-3978.

Habuchi, S. (2014). "Super-resolution molecular and functional imaging of nanoscale architectures in life and materials science." Front Bioeng Biotechnol **2**: 20.

Han, J., C. J. Lim, N. Watanabe, A. Soriani, B. Ratnikov, D. A. Calderwood, W. Puzon-McLaughlin, E. M. Lafuente, V. A. Boussiotis, S. J. Shattil and M. H. Ginsberg (2006). "Reconstructing and deconstructing agonist-induced activation of integrin α IIb β 3." Curr Biol **16**(18): 1796-1806.

Hasegawa, K., F. Martin, G. Huang, D. Tumas, L. Diehl and A. C. Chan (2004). "PEST domain-enriched tyrosine phosphatase (PEP) regulation of effector/memory T cells." Science **303**(5658): 685-689.

Heilemann, M., S. van de Linde, M. Schuttpelz, R. Kasper, B. Seefeldt, A. Mukherjee, P. Tinnefeld and M. Sauer (2008). "Subdiffraction-resolution fluorescence imaging with conventional fluorescent probes." Angew Chem Int Ed Engl **47**(33): 6172-6176.

Hill, R. J., S. Zozulya, Y. L. Lu, K. Ward, M. Gishizky and B. Jallal (2002). "The lymphoid protein tyrosine phosphatase Lyp interacts with the adaptor molecule Grb2 and functions as a negative regulator of T-cell activation." Exp Hematol **30**(3): 237-244.

Hinks, A., A. Barton, S. John, I. Bruce, C. Hawkins, C. E. Griffiths, R. Donn, W. Thomson, A. Silman and J. Worthington (2005). "Association between the PTPN22 gene and rheumatoid arthritis and juvenile idiopathic arthritis in a UK population: further support that PTPN22 is an autoimmunity gene." Arthritis Rheum **52**(6): 1694-1699.

Hogg, N., J. Harvey, C. Cabanas and R. C. Landis (1993). "Control of leukocyte integrin activation." Am Rev Respir Dis **148**(6 Pt 2): S55-59.

Hogg, N., I. Patzak and F. Willenbrock (2011). "The insider's guide to leukocyte integrin signalling and function." Nat Rev Immunol **11**(6): 416-426.

Hrdinka, M. and V. Horejsi (2013). "PAG - a multipurpose transmembrane adaptor protein." Oncogene.

Huang, J. J., Y. R. Qiu, H. X. Li, D. H. Sun, J. Yang and C. L. Yang (2010). "A PTPN22 promoter polymorphism -1123G>C is associated with RA pathogenesis in Chinese." Rheumatol Int.

Huppa, J. B., M. Gleimer, C. Sumen and M. M. Davis (2003). "Continuous T cell receptor signaling required for synapse maintenance and full effector potential." Nat Immunol **4**(8): 749-755.

Hynes, R. O. (2002). "Integrins: bidirectional, allosteric signaling machines." Cell **110**(6): 673-687.

Ioannidis, J. P., E. E. Ntzani, T. A. Trikalinos and D. G. Contopoulos-Ioannidis (2001). "Replication validity of genetic association studies." Nat Genet **29**(3): 306-309.

Ittah, M., J. E. Gottenberg, A. Proust, E. Hachulla, X. Puechal, P. Loiseau, X. Mariette and C. Miceli-Richard (2005). "No evidence for association between 1858 C/T single-nucleotide polymorphism of PTPN22 gene and primary Sjogren's syndrome." Genes Immun **6**(5): 457-458.

Jakus, Z., S. Fodor, C. L. Abram, C. A. Lowell and A. Mocsai (2007). "Immunoreceptor-like signaling by beta 2 and beta 3 integrins." Trends Cell Biol **17**(10): 493-501.

Jenkins, M. R., J. C. Stinchcombe, B. B. Au-Yeung, Y. Asano, A. T. Ritter, A. Weiss and G. M. Griffiths (2014). "Distinct structural and catalytic roles for Zap70 in formation of the immunological synapse in CTL." Elife **3**: e01310.

Katagiri, K., M. Hattori, N. Minato, S. Irie, K. Takatsu and T. Kinashi (2000). "Rap1 is a potent activation signal for leukocyte function-associated antigen 1 distinct from protein kinase C and phosphatidylinositol-3-OH kinase." Mol Cell Biol **20**(6): 1956-1969.

Katagiri, K., A. Maeda, M. Shimonaka and T. Kinashi (2003). "RAPL, a Rap1-binding molecule that mediates Rap1-induced adhesion through spatial regulation of LFA-1." Nat Immunol **4**(8): 741-748.

Katagiri, K., M. Shimonaka and T. Kinashi (2004). "Rap1-mediated lymphocyte function-associated antigen-1 activation by the T cell antigen receptor is dependent on phospholipase C-gamma1." J Biol Chem **279**(12): 11875-11881.

Kawasaki, E., T. Awata, H. Ikegami, T. Kobayashi, T. Maruyama, K. Nakanishi, A. Shimada, M. Uga, S. Kurihara, Y. Kawabata, S. Tanaka, Y. Kanazawa, I. Lee and K. Eguchi (2006). "Systematic search for single nucleotide polymorphisms in a lymphoid tyrosine phosphatase gene (PTPN22): association between a promoter polymorphism and type 1 diabetes in Asian populations." Am J Med Genet A **140**(6): 586-593.

Kim, M., C. V. Carman, W. Yang, A. Salas and T. A. Springer (2004). "The primacy of affinity over clustering in regulation of adhesiveness of the integrin {alpha}{beta}2." J Cell Biol **167**(6): 1241-1253.

Kinashi, T. (2005). "Intracellular signalling controlling integrin activation in lymphocytes." Nat Rev Immunol **5**(7): 546-559.

Kinashi, T., M. Aker, M. Sokolovsky-Eisenberg, V. Grabovsky, C. Tanaka, R. Shamri, S. Feigelson, A. Etzioni and R. Alon (2004). "LAD-III, a leukocyte adhesion deficiency syndrome associated with defective Rap1 activation and impaired stabilization of integrin bonds." Blood **103**(3): 1033-1036.

Kliche, S., D. Breitling, M. Togni, R. Pusch, K. Heuer, X. Wang, C. Freund, A. Kasirer-Friede, G. Menasche, G. A. Koretzky and B. Schraven (2006). "The ADAP/SKAP55 signaling module regulates T-cell receptor-mediated integrin activation through plasma membrane targeting of Rap1." Mol Cell Biol **26**(19): 7130-7144.

Kozlowski, M., I. Mlinaric-Rascan, G. S. Feng, R. Shen, T. Pawson and K. A. Siminovitch (1993). "Expression and catalytic activity of the tyrosine phosphatase PTP1C is severely impaired in motheaten and viable motheaten mice." J Exp Med **178**(6): 2157-2163.

Kremer, K. N., T. D. Humphreys, A. Kumar, N. X. Qian and K. E. Hedin (2003). "Distinct role of ZAP-70 and Src homology 2 domain-containing leukocyte protein of 76 kDa in the prolonged activation of extracellular signal-regulated protein kinase by the stromal cell-derived factor-1 alpha/CXCL12 chemokine." J Immunol **171**(1): 360-367.

Kumar, A., T. D. Humphreys, K. N. Kremer, P. S. Bramati, L. Bradfield, C. E. Edgar and K. E. Hedin (2006). "CXCR4 physically associates with the T cell receptor to signal in T cells." Immunity **25**(2): 213-224.

Kyogoku, C., C. D. Langefeld, W. A. Ortmann, A. Lee, S. Selby, V. E. Carlton, M. Chang, P. Ramos, E. C. Baechler, F. M. Batliwalla, J. Novitzke, A. H. Williams, C. Gillett, P. Rodine, R. R. Graham, K. G. Ardlie, P. M. Gaffney, K. L. Moser, M. Petri, A. B. Begovich, P. K. Gregersen and T. W. Behrens (2004). "Genetic association of the R620W polymorphism of protein tyrosine phosphatase PTPN22 with human SLE." Am J Hum Genet **75**(3): 504-507.

Lamsyah, H., B. Rueda, L. Baassi, R. Elaouad, N. Bottini, K. Sadki and J. Martin (2009). "Association of PTPN22 gene functional variants with development of pulmonary tuberculosis in Moroccan population." Tissue Antigens **74**(3): 228-232.

Landis, R. C., R. I. Bennett and N. Hogg (1993). "A novel LFA-1 activation epitope maps to the I domain." J Cell Biol **120**(6): 1519-1527.

Lefvert, A. K., Y. Zhao, R. Ramanujam, S. Yu, R. Pirskanen and L. Hammarstrom (2008). "PTPN22 R620W promotes production of anti-AChR autoantibodies and IL-2 in myasthenia gravis." J Neuroimmunol **197**(2): 110-113.

Lek, H. S., V. L. Morrison, M. Conneely, P. A. Campbell, D. McGloin, S. Kliche, C. Watts, A. Prescott and S. C. Fagerholm (2013). "The spontaneously adhesive leukocyte function-associated antigen-1 (LFA-1) integrin in effector T cells mediates rapid actin- and calmodulin-dependent adhesion strengthening to ligand under shear flow." J Biol Chem **288**(21): 14698-14708.

Levinson, N. M., P. R. Visperas and J. Kuriyan (2009). "The tyrosine kinase Csk dimerizes through its SH3 domain." PLoS One **4**(11): e7683.

Liu, Y., S. M. Stanford, S. P. Jog, E. Fiorillo, V. Orru, L. Comai and N. Bottini (2009). "Regulation of lymphoid tyrosine phosphatase activity: inhibition of the catalytic domain by the proximal interdomain." Biochemistry **48**(31): 7525-7532.

Lopez-Escamez, J. A. (2010). "A variant of PTPN22 gene conferring risk to autoimmune diseases may protect against tuberculosis." J Postgrad Med **56**(3): 242-243.

Luo, B. H., C. V. Carman and T. A. Springer (2007). "Structural basis of integrin regulation and signaling." Annu Rev Immunol **25**: 619-647.

Lupher, M. L., Jr., Z. Songyang, S. E. Shoelson, L. C. Cantley and H. Band (1997). "The Cbl phosphotyrosine-binding domain selects a D(N/D)XpY motif and binds to the Tyr292 negative regulatory phosphorylation site of ZAP-70." J Biol Chem **272**(52): 33140-33144.

Maine, C. J., K. Marquardt, J. Cheung and L. A. Sherman (2014). "PTPN22 controls the germinal center by influencing the numbers and activity of T follicular helper cells." J Immunol **192**(4): 1415-1424.

Majeti, R., A. M. Bilwes, J. P. Noel, T. Hunter and A. Weiss (1998). "Dimerization-induced inhibition of receptor protein tyrosine phosphatase function through an inhibitory wedge." Science **279**(5347): 88-91.

Majeti, R., Z. Xu, T. G. Parslow, J. L. Olson, D. I. Daikh, N. Killeen and A. Weiss (2000). "An inactivating point mutation in the inhibitory wedge of CD45 causes lymphoproliferation and autoimmunity." Cell **103**(7): 1059-1070.

Maksumova, L., H. T. Le, F. Muratkhodjaev, D. Davidson, A. Veillette and C. J. Pallen (2005). "Protein tyrosine phosphatase alpha regulates Fyn activity and Cbp/PAG phosphorylation in thymocyte lipid rafts." J Immunol **175**(12): 7947-7956.

Malinin, N. L., L. Zhang, J. Choi, A. Ciocea, O. Razorenova, Y. Q. Ma, E. A. Podrez, M. Tosi, D. P. Lennon, A. I. Caplan, S. B. Shurin, E. F. Plow and T. V. Byzova (2009). "A point mutation in KINDLIN3 ablates activation of three integrin subfamilies in humans." Nat Med **15**(3): 313-318.

Manevich-Mendelson, E., S. W. Feigelson, R. Pasvolsky, M. Aker, V. Grabovsky, Z. Shulman, S. S. Kilic, M. A. Rosenthal-Allieri, S. Ben-Dor, A. Mory, A. Bernard, M. Moser, A. Etzioni and R. Alon (2009). "Loss of Kindlin-3 in LAD-III eliminates LFA-1 but not VLA-4 adhesiveness developed under shear flow conditions." Blood **114**(11): 2344-2353.

Martel, V., C. Rocaud-Sultan, S. Dupe, C. Marie, F. Paulhe, A. Galmiche, M. R. Block and C. Albiges-Rizo (2001). "Conformation, localization, and integrin binding of talin depend on its interaction with phosphoinositides." J Biol Chem **276**(24): 21217-21227.

Matthews, R. J., D. B. Bowne, E. Flores and M. L. Thomas (1992). "Characterization of hematopoietic intracellular protein tyrosine phosphatases: description of a phosphatase containing an SH2 domain and another enriched in proline-, glutamic acid-, serine-, and threonine-rich sequences." Mol Cell Biol **12**(5): 2396-2405.

McPartland, J. M., R. W. Norris and C. W. Kilpatrick (2007). "Tempo and mode in the endocannabinoid system." J Mol Evol **65**(3): 267-276.

Mempel, T. R., S. E. Henrickson and U. H. Von Andrian (2004). "T-cell priming by dendritic cells in lymph nodes occurs in three distinct phases." Nature **427**(6970): 154-159.

Menard, L., D. Saadoun, I. Isnardi, Y. S. Ng, G. Meyers, C. Massad, C. Price, C. Abraham, R. Motaghedi, J. H. Buckner, P. K. Gregersen and E. Meffre (2011). "The PTPN22 allele encoding an R620W variant interferes with the removal of developing autoreactive B cells in humans." J Clin Invest **121**(9): 3635-3644.

Menasche, G., S. Kliche, E. J. Chen, T. E. Stradal, B. Schraven and G. Koretzky (2007). "RIAM links the ADAP/SKAP-55 signaling module to Rap1, facilitating T-cell-receptor-mediated integrin activation." Mol Cell Biol **27**(11): 4070-4081.

Micouin, A., J. Wietzerbin, V. Steunou and M. C. Martyre (2000). "p95(vav) associates with the type I interferon (IFN) receptor and contributes to the antiproliferative effect of IFN-alpha in megakaryocytic cell lines." Oncogene **19**(3): 387-394.

Miller, M. J., S. H. Wei, I. Parker and M. D. Cahalan (2002). "Two-photon imaging of lymphocyte motility and antigen response in intact lymph node." Science **296**(5574): 1869-1873.

Mocsai, A., C. L. Abram, Z. Jakus, Y. Hu, L. L. Lanier and C. A. Lowell (2006). "Integrin signaling in neutrophils and macrophages uses adaptors containing immunoreceptor tyrosine-based activation motifs." Nat Immunol **7**(12): 1326-1333.

Mocsai, A., H. Zhang, Z. Jakus, J. Kitaura, T. Kawakami and C. A. Lowell (2003). "G-protein-coupled receptor signaling in Syk-deficient neutrophils and mast cells." Blood **101**(10): 4155-4163.

Mocsai, A., M. Zhou, F. Meng, V. L. Tybulewicz and C. A. Lowell (2002). "Syk is required for integrin signaling in neutrophils." Immunity **16**(4): 547-558.

Montes-Cano, M. A., J. R. Garcia-Lozano, J. Aguilar-Reina, M. Romero-Gomez, N. Barroso, A. Nunez-Roldan, J. Martin and M. F. Gonzalez-Escribano (2008). "PTPN22 C1858T polymorphism and the outcome of hepatitis C virus infection." Viral Immunol **21**(4): 491-494.

Mor, A., J. P. Wynne, I. M. Ahearn, M. L. Dustin, G. Du and M. R. Philips (2009). "Phospholipase D1 regulates lymphocyte adhesion via upregulation of Rap1 at the plasma membrane." Mol Cell Biol **29**(12): 3297-3306.

Moser, M., M. Bauer, S. Schmid, R. Ruppert, S. Schmidt, M. Sixt, H. V. Wang, M. Sperandio and R. Fassler (2009). "Kindlin-3 is required for beta2 integrin-mediated leukocyte adhesion to endothelial cells." Nat Med **15**(3): 300-305.

Moser, M., B. Nieswandt, S. Ussar, M. Pozgajova and R. Fassler (2008). "Kindlin-3 is essential for integrin activation and platelet aggregation." Nat Med **14**(3): 325-330.

Munger, J. S. and D. Sheppard (2011). "Cross talk among TGF-beta signaling pathways, integrins, and the extracellular matrix." Cold Spring Harb Perspect Biol **3**(11): a005017.

Mustelin, T., A. Alonso, N. Bottini, H. Huynh, S. Rahmouni, K. Nika, C. Louis-dit-Sully, L. Tautz, S. H. Togo, S. Bruckner, A. V. Mena-Duran and A. M. al-Khoury (2004). "Protein tyrosine phosphatases in T cell physiology." Mol Immunol **41**(6-7): 687-700.

Mustelin, T. and K. Tasken (2003). "Positive and negative regulation of T-cell activation through kinases and phosphatases." Biochem J **371**(Pt 1): 15-27.

Mustelin, T., T. Vang and N. Bottini (2005). "Protein tyrosine phosphatases and the immune response." Nat Rev Immunol **5**(1): 43-57.

Naci, D. and F. Aoudjit (2014). "Alpha2beta1 integrin promotes T cell survival and migration through the concomitant activation of ERK/Mcl-1 and p38 MAPK pathways." Cell Signal **26**(9): 2008-2015.

Nika, K., C. Soldani, M. Salek, W. Paster, A. Gray, R. Etzensperger, L. Fugger, P. Polzella, V. Cerundolo, O. Dushek, T. Hofer, A. Viola and O. Acuto (2010). "Constitutively active Lck kinase in T cells drives antigen receptor signal transduction." Immunity **32**(6): 766-777.

Nika, K., L. Tautz, Y. Arimura, T. Vang, S. Williams and T. Mustelin (2007). "A weak Lck tail bite is necessary for Lck function in T cell antigen receptor signaling." J Biol Chem **282**(49): 36000-36009.

Nolz, J. C., T. S. Gomez, P. Zhu, S. Li, R. B. Medeiros, Y. Shimizu, J. K. Burkhardt, B. D. Freedman and D. D. Billadeau (2006). "The WAVE2 complex regulates actin cytoskeletal reorganization and CRAC-mediated calcium entry during T cell activation." Curr Biol **16**(1): 24-34.

Nunes, J. A., Y. Collette, A. Truneh, D. Olive and D. A. Cantrell (1994). "The role of p21ras in CD28 signal transduction: triggering of CD28 with antibodies, but not the ligand B7-1, activates p21ras." J Exp Med **180**(3): 1067-1076.

Obergfell, A., B. A. Judd, M. A. del Pozo, M. A. Schwartz, G. A. Koretzky and S. J. Shattil (2001). "The molecular adapter SLP-76 relays signals from platelet integrin α IIb β 3 to the actin cytoskeleton." J Biol Chem **276**(8): 5916-5923.

Orozco, G., E. Sanchez, M. A. Gonzalez-Gay, M. A. Lopez-Nevot, B. Torres, R. Caliz, N. Ortego-Centeno, J. Jimenez-Alonso, D. Pascual-Salcedo, A. Balsa, R. de Pablo, A. Nunez-Roldan, M. F. Gonzalez-Escribano and J. Martin (2005). "Association of a functional single-nucleotide polymorphism of PTPN22, encoding lymphoid protein phosphatase, with rheumatoid arthritis and systemic lupus erythematosus." Arthritis Rheum **52**(1): 219-224.

Orru, V., S. J. Tsai, B. Rueda, E. Fiorillo, S. M. Stanford, J. Dasgupta, J. Hartiala, L. Zhao, N. Ortego-Centeno, S. D'Alfonso, F. C. Arnett, H. Wu, M. A. Gonzalez-Gay, B. P. Tsao, B. Pons-Estel, M. E. Alarcon-Riquelme, Y. He, Z. Y. Zhang, H. Allayee, X. S. Chen, J. Martin and N. Bottini (2009). "A loss-of-function variant of PTPN22 is associated with reduced risk of systemic lupus erythematosus." Hum Mol Genet **18**(3): 569-579.

Osisanya, J. O., S. C. Sehgal and A. Iyanda (1990). "Pattern of genito-urinary parasitic infections at the Teaching Hospital, Sokoto, Nigeria." East Afr Med J **67**(1): 51-57.

Parish, C. R. (2006). "The role of heparan sulphate in inflammation." Nat Rev Immunol **6**(9): 633-643.

Park, E. J., A. Peixoto, Y. Imai, A. Goodarzi, G. Cheng, C. V. Carman, U. H. von Andrian and M. Shimaoka (2010). "Distinct roles for LFA-1 affinity regulation during T-cell adhesion, diapedesis, and interstitial migration in lymph nodes." Blood **115**(8): 1572-1581.

Paster, W., C. Paar, P. Eckerstorfer, A. Jakober, K. Drbal, G. J. Schutz, A. Sonnleitner and H. Stockinger (2009). "Genetically encoded Förster resonance energy transfer sensors for the conformation of the Src family kinase Lck." J Immunol **182**(4): 2160-2167.

Pasvolsky, R., S. W. Feigelson, S. S. Kilic, A. J. Simon, G. Tal-Lapidot, V. Grabovsky, J. R. Crittenden, N. Amariglio, M. Safran, A. M. Graybiel, G. Rechavi, S. Ben-Dor, A. Etzioni and R. Alon (2007). "A LAD-III syndrome is associated with defective expression of the Rap-1 activator CalDAG-GEFI in lymphocytes, neutrophils, and platelets." J Exp Med **204**(7): 1571-1582.

Perry, G. L. (2004). "SpPack: spatial point pattern analysis in Excel using Visual Basic for Applications (VBA)." Environmental Modelling & Software **19**(6): 559-569.

Petricoin, E. F., 3rd, S. Ito, B. L. Williams, S. Audet, L. F. Stancato, A. Gamero, K. Clouse, P. Grimley, A. Weiss, J. Beeler, D. S. Finbloom, E. W. Shores, R. Abraham and A. C. Larner (1997). "Antiproliferative action of interferon-alpha requires components of T-cell-receptor signalling." Nature **390**(6660): 629-632.

Pierce, S. K. and W. Liu (2010). "The tipping points in the initiation of B cell signalling: how small changes make big differences." Nat Rev Immunol **10**(11): 767-777.

Puklin-Faucher, E., M. Gao, K. Schulten and V. Vogel (2006). "How the headpiece hinge angle is opened: New insights into the dynamics of integrin activation." J Cell Biol **175**(2): 349-360.

Raab, M., H. Wang, Y. Lu, X. Smith, Z. Wu, K. Strebhardt, J. E. Ladbury and C. E. Rudd (2010). "T cell receptor "inside-out" pathway via signaling module SKAP1-RapL regulates T cell motility and interactions in lymph nodes." Immunity **32**(4): 541-556.

Rego, E. H., L. Shao, J. J. Macklin, L. Winoto, G. A. Johansson, N. Kamps-Hughes, M. W. Davidson and M. G. Gustafsson (2012). "Nonlinear structured-illumination microscopy with a photoswitchable protein reveals cellular structures at 50-nm resolution." Proc Natl Acad Sci U S A **109**(3): E135-143.

Ridley, A. J. (2011). "Life at the leading edge." Cell **145**(7): 1012-1022.

- Rieck, M., A. Arechiga, S. Onengut-Gumuscu, C. Greenbaum, P. Concannon and J. H. Buckner (2007). "Genetic variation in PTPN22 corresponds to altered function of T and B lymphocytes." J Immunol **179**(7): 4704-4710.
- Ripley, B. (1979). "Tests of randomness' for spatial point patterns." Journal of the Royal Statistical Society. Series B (Methodological): 368-374.
- Ripley, B. D. (1977). "Modelling spatial patterns." Journal of the Royal Statistical Society. Series B (Methodological): 172-212.
- Robledo, G., C. I. Gonzalez, C. Morillo, J. Martin and A. Gonzalez (2007). "Association study of PTPN22 C1858T polymorphism in Trypanosoma cruzi infection." Tissue Antigens **69**(3): 261-264.
- Roskoski, R., Jr. (2012). "ERK1/2 MAP kinases: structure, function, and regulation." Pharmacol Res **66**(2): 105-143.
- Rust, M. J., M. Bates and X. Zhuang (2006). "Sub-diffraction-limit imaging by stochastic optical reconstruction microscopy (STORM)." Nat Methods **3**(10): 793-795.
- Saito, K., S. Williams, A. Bulankina, S. Honing and T. Mustelin (2007). "Association of protein-tyrosine phosphatase MEG2 via its Sec14p homology domain with vesicle-trafficking proteins." J Biol Chem **282**(20): 15170-15178.
- Sakaguchi, S., M. Ono, R. Setoguchi, H. Yagi, S. Hori, Z. Fehervari, J. Shimizu, T. Takahashi and T. Nomura (2006). "Foxp3+ CD25+ CD4+ natural regulatory T cells in dominant self-tolerance and autoimmune disease." Immunol Rev **212**: 8-27.
- Salmond, R. J., R. J. Brownlie, V. L. Morrison and R. Zamoyska (2014). "The tyrosine phosphatase PTPN22 discriminates weak self peptides from strong agonist TCR signals." Nat Immunol **15**(9): 875-883.
- Schermelleh, L., P. M. Carlton, S. Haase, L. Shao, L. Winoto, P. Kner, B. Burke, M. C. Cardoso, D. A. Agard, M. G. Gustafsson, H. Leonhardt and J. W. Sedat (2008). "Subdiffraction multicolor imaging of the nuclear periphery with 3D structured illumination microscopy." Science **320**(5881): 1332-1336.

Schneider, H., Y. C. Cai, K. V. Prasad, S. E. Shoelson and C. E. Rudd (1995). "T cell antigen CD28 binds to the GRB-2/SOS complex, regulators of p21ras." Eur J Immunol **25**(4): 1044-1050.

Schoenborn, J. R., Y. X. Tan, C. Zhang, K. M. Shokat and A. Weiss (2011). "Feedback circuits monitor and adjust basal Lck-dependent events in T cell receptor signaling." Sci Signal **4**(190): ra59.

Schumann, K., T. Lammermann, M. Bruckner, D. F. Legler, J. Polleux, J. P. Spatz, G. Schuler, R. Forster, M. B. Lutz, L. Sorokin and M. Sixt (2010). "Immobilized chemokine fields and soluble chemokine gradients cooperatively shape migration patterns of dendritic cells." Immunity **32**(5): 703-713.

Schymeinsky, J., A. Sindrilaru, D. Frommhold, M. Sperandio, R. Gerstl, C. Then, A. Mocsai, K. Scharffetter-Kochanek and B. Walzog (2006). "The Vav binding site of the non-receptor tyrosine kinase Syk at Tyr 348 is critical for beta2 integrin (CD11/CD18)-mediated neutrophil migration." Blood **108**(12): 3919-3927.

Schymeinsky, J., C. Then and B. Walzog (2005). "The non-receptor tyrosine kinase Syk regulates lamellipodium formation and site-directed migration of human leukocytes." J Cell Physiol **204**(2): 614-622.

Sebzda, E., M. Bracke, T. Tugal, N. Hogg and D. A. Cantrell (2002). "Rap1A positively regulates T cells via integrin activation rather than inhibiting lymphocyte signaling." Nat Immunol **3**(3): 251-258.

Seldin, M. F., R. Shigeta, K. Laiho, H. Li, H. Saila, A. Savolainen, M. Leirisalo-Repo, K. Aho, E. Tuomilehto-Wolf, K. Kaarela, M. Kauppi, H. C. Alexander, A. B. Begovich and J. Tuomilehto (2005). "Finnish case-control and family studies support PTPN22 R620W polymorphism as a risk factor in rheumatoid arthritis, but suggest only minimal or no effect in juvenile idiopathic arthritis." Genes Immun **6**(8): 720-722.

Shamri, R., V. Grabovsky, J. M. Gauguet, S. Feigelson, E. Manevich, W. Kolanus, M. K. Robinson, D. E. Staunton, U. H. von Andrian and R. Alon (2005). "Lymphocyte arrest requires

instantaneous induction of an extended LFA-1 conformation mediated by endothelium-bound chemokines." Nat Immunol **6**(5): 497-506.

Sherman, E., V. Barr, S. Manley, G. Patterson, L. Balagopalan, I. Akpan, C. K. Regan, R. K. Merrill, C. L. Sommers, J. Lippincott-Schwartz and L. E. Samelson (2011). "Functional nanoscale organization of signaling molecules downstream of the T cell antigen receptor." Immunity **35**(5): 705-720.

Shimonaka, M., K. Katagiri, T. Nakayama, N. Fujita, T. Tsuruo, O. Yoshie and T. Kinashi (2003). "Rap1 translates chemokine signals to integrin activation, cell polarization, and motility across vascular endothelium under flow." J Cell Biol **161**(2): 417-427.

Siggs, O. M., L. A. Miosge, A. L. Yates, E. M. Kucharska, D. Sheahan, T. Brdicka, A. Weiss, A. Liston and C. C. Goodnow (2007). "Opposing functions of the T cell receptor kinase ZAP-70 in immunity and tolerance differentially titrate in response to nucleotide substitutions." Immunity **27**(6): 912-926.

Skorka, A., T. Bednarczuk, E. Bar-Andziak, J. Nauman and R. Ploski (2005). "Lymphoid tyrosine phosphatase (PTPN22/LYP) variant and Graves' disease in a Polish population: association and gene dose-dependent correlation with age of onset." Clin Endocrinol (Oxf) **62**(6): 679-682.

Smith-Garvin, J. E., G. A. Koretzky and M. S. Jordan (2009). "T cell activation." Annu Rev Immunol **27**: 591-619.

Smyth, D., J. D. Cooper, J. E. Collins, J. M. Heward, J. A. Franklyn, J. M. Howson, A. Vella, S. Nutland, H. E. Rance, L. Maier, B. J. Barratt, C. Guja, C. Ionescu-Tirgoviste, D. A. Savage, D. B. Dunger, B. Widmer, D. P. Strachan, S. M. Ring, N. Walker, D. G. Clayton, R. C. Twells, S. C. Gough and J. A. Todd (2004). "Replication of an association between the lymphoid tyrosine phosphatase locus (LYP/PTPN22) with type 1 diabetes, and evidence for its role as a general autoimmunity locus." Diabetes **53**(11): 3020-3023.

Spalinger, M. R., S. Lang, S. R. Vavricka, M. Fried, G. Rogler and M. Scharl (2013). "Protein tyrosine phosphatase non-receptor type 22 modulates NOD2-induced cytokine release and autophagy." PLoS One **8**(8): e72384.

Spalinger, M. R., S. Lang, A. Weber, P. Frei, M. Fried, G. Rogler and M. Scharl (2013). "Loss of protein tyrosine phosphatase nonreceptor type 22 regulates interferon-gamma-induced signaling in human monocytes." Gastroenterology **144**(5): 978-988.e910.

Spencer, S., D. Dowbenko, J. Cheng, W. Li, J. Brush, S. Utzig, V. Simanis and L. A. Lasky (1997). "PSTPIP: a tyrosine phosphorylated cleavage furrow-associated protein that is a substrate for a PEST tyrosine phosphatase." J Cell Biol **138**(4): 845-860.

Springer, T. A. (1993). "Signals on endothelium for lymphocyte recirculation and leukocyte emigration: the area code paradigm." Harvey Lect **89**: 53-103.

Springer, T. A. (1994). "Traffic signals for lymphocyte recirculation and leukocyte emigration: the multistep paradigm." Cell **76**(2): 301-314.

Springer, T. A. (1995). "Traffic signals on endothelium for lymphocyte recirculation and leukocyte emigration." Annu Rev Physiol **57**: 827-872.

Stepanek, O., P. Draber and V. Horejsi (2014). "Palmitoylated transmembrane adaptor proteins in leukocyte signaling." Cell Signal **26**(5): 895-902.

Stephens, P., J. T. Romer, M. Spitali, A. Shock, S. Ortlepp, C. G. Figdor and M. K. Robinson (1995). "KIM127, an antibody that promotes adhesion, maps to a region of CD18 that includes cysteine-rich repeats." Cell Adhes Commun **3**(5): 375-384.

Stevens, C. N., A. M. Simeone, S. John, Z. Ahmed, O. M. Lucherini, C. T. Baldari and J. E. Ladbury (2010). "T-cell receptor early signalling complex activation in response to interferon-alpha receptor stimulation." Biochem J **428**(3): 429-437.

Svensson, L., K. Howarth, A. McDowall, I. Patzak, R. Evans, S. Ussar, M. Moser, A. Metin, M. Fried, I. Tomlinson and N. Hogg (2009). "Leukocyte adhesion deficiency-III is caused by mutations in KINDLIN3 affecting integrin activation." Nat Med **15**(3): 306-312.

Swat, W. and K. Fujikawa (2005). "The Vav family: at the crossroads of signaling pathways." Immunol Res **32**(1-3): 259-265.

Tan, S. M. (2012). "The leucocyte beta2 (CD18) integrins: the structure, functional regulation and signalling properties." Biosci Rep **32**(3): 241-269.

Tan, Y. X., B. N. Manz, T. S. Freedman, C. Zhang, K. M. Shokat and A. Weiss (2014). "Inhibition of the kinase Csk in thymocytes reveals a requirement for actin remodeling in the initiation of full TCR signaling." Nat Immunol **15**(2): 186-194.

Tanaka, T., E. Umemoto and M. Miyasaka (2006). "[Lymphocyte trafficking and immunesurveillance]." Nihon Rinsho Meneki Gakkai Kaishi **29**(6): 359-371.

Ticchioni, M., C. Charvet, N. Noraz, L. Lamy, M. Steinberg, A. Bernard and M. Deckert (2002). "Signaling through ZAP-70 is required for CXCL12-mediated T-cell transendothelial migration." Blood **99**(9): 3111-3118.

Tong, H., B. Zhao, H. Shi, X. Ba, X. Wang, Y. Jiang and X. Zeng (2013). "c-Abl tyrosine kinase plays a critical role in beta2 integrin-dependent neutrophil migration by regulating Vav1 activity." J Leukoc Biol **93**(4): 611-622.

Tonks, N. K. (2006). "Protein tyrosine phosphatases: from genes, to function, to disease." Nat Rev Mol Cell Biol **7**(11): 833-846.

Torgersen, K. M., T. Vang, H. Abrahamsen, S. Yaqub, V. Horejsi, B. Schraven, B. Rolstad, T. Mustelin and K. Tasken (2001). "Release from tonic inhibition of T cell activation through transient displacement of C-terminal Src kinase (Csk) from lipid rafts." J Biol Chem **276**(31): 29313-29318.

Totani, L., A. Piccoli, S. Manarini, L. Federico, R. Pecce, N. Martelli, C. Cerletti, P. Piccardoni, C. A. Lowell, S. S. Smyth, G. Berton and V. Evangelista (2006). "Src-family kinases mediate an outside-in signal necessary for beta2 integrins to achieve full activation and sustain firm adhesion of polymorphonuclear leucocytes tethered on E-selectin." Biochem J **396**(1): 89-98.

Treanor, B., D. Depoil, A. Gonzalez-Granja, P. Barral, M. Weber, O. Dushek, A. Bruckbauer and F. D. Batista (2010). "The membrane skeleton controls diffusion dynamics and signaling through the B cell receptor." Immunity **32**(2): 187-199.

Tsai, S. J., U. Sen, L. Zhao, W. B. Greenleaf, J. Dasgupta, E. Fiorillo, V. Orru, N. Bottini and X. S. Chen (2009). "Crystal structure of the human lymphoid tyrosine phosphatase catalytic domain: insights into redox regulation." Biochemistry **48**(22): 4838-4845.

- Tsui, F. W. and H. W. Tsui (1994). "Molecular basis of the motheaten phenotype." Immunol Rev **138**: 185-206.
- Uchida, Y., M. Ogata, Y. Mori, M. Oh-hora, N. Hatano and T. Hamaoka (2002). "Localization of PTP-FERM in nerve processes through its FERM domain." Biochem Biophys Res Commun **292**(1): 13-19.
- Ulmer, T. S., D. A. Calderwood, M. H. Ginsberg and I. D. Campbell (2003). "Domain-specific interactions of talin with the membrane-proximal region of the integrin beta3 subunit." Biochemistry **42**(27): 8307-8312.
- van de Vijver, E., A. T. Tool, O. Sanal, M. Cetin, S. Unal, S. Aytac, K. Seeger, D. Pagliara, S. Rutella, T. K. van den Berg and T. W. Kuijpers (2014). "Kindlin-3-independent adhesion of neutrophils from patients with leukocyte adhesion deficiency type III." J Allergy Clin Immunol **133**(4): 1215-1218.
- Vandiedonck, C., C. Capdevielle, M. Giraud, S. Krumeich, J. P. Jais, B. Eymard, C. Tranchant, P. Gajdos and H. J. Garchon (2006). "Association of the PTPN22*R620W polymorphism with autoimmune myasthenia gravis." Ann Neurol **59**(2): 404-407.
- Vang, T., W. H. Liu, L. Delacroix, S. Wu, S. Vasile, R. Dahl, L. Yang, L. Musumeci, D. Francis, J. Landskron, K. Tasken, M. L. Tremblay, B. A. Lie, R. Page, T. Mustelin, S. Rahmouni, R. C. Rickert and L. Tautz (2012). "LYP inhibits T-cell activation when dissociated from CSK." Nat Chem Biol **8**(5): 437-446.
- Velaga, M. R., V. Wilson, C. E. Jennings, C. J. Owen, S. Herington, P. T. Donaldson, S. G. Ball, R. A. James, R. Quinton, P. Perros and S. H. Pearce (2004). "The codon 620 tryptophan allele of the lymphoid tyrosine phosphatase (LYP) gene is a major determinant of Graves' disease." J Clin Endocrinol Metab **89**(11): 5862-5865.
- Ventimiglia, L. N. and M. A. Alonso (2013). "The role of membrane rafts in Lck transport, regulation and signalling in T-cells." Biochem J **454**(2): 169-179.

Vielreicher, M., G. Harms, E. Butt, U. Walter and A. Oberfell (2007). "Dynamic interaction between Src and C-terminal Src kinase in integrin alphaIIb beta3-mediated signaling to the cytoskeleton." J Biol Chem **282**(46): 33623-33631.

Viken, M. K., S. S. Amundsen, T. K. Kvien, K. M. Boberg, I. M. Gilboe, V. Lilleby, L. M. Sollid, O. T. Forre, E. Thorsby, A. Smerdel and B. A. Lie (2005). "Association analysis of the 1858C>T polymorphism in the PTPN22 gene in juvenile idiopathic arthritis and other autoimmune diseases." Genes Immun **6**(3): 271-273.

von Andrian, U. H. and K. E. Arfors (1993). "Neutrophil-endothelial cell interactions in vivo: a chain of events characterized by distinct molecular mechanisms." Agents Actions Suppl **41**: 153-164.

von Andrian, U. H. and C. R. Mackay (2000). "T-cell function and migration. Two sides of the same coin." N Engl J Med **343**(14): 1020-1034.

Waisberg, M., T. Tarasenko, B. K. Vickers, B. L. Scott, L. C. Willcocks, A. Molina-Cruz, M. A. Pierce, C. Y. Huang, F. J. Torres-Velez, K. G. Smith, C. Barillas-Mury, L. H. Miller, S. K. Pierce and S. Bolland (2010). "Genetic susceptibility to systemic lupus erythematosus protects against cerebral malaria in mice." Proc Natl Acad Sci U S A.

Waldman, M. and M. P. Madaio (2005). "Pathogenic autoantibodies in lupus nephritis." Lupus **14**(1): 19-24.

Wang, H., T. A. Kadlecsek, B. B. Au-Yeung, H. E. Goodfellow, L. Y. Hsu, T. S. Freedman and A. Weiss (2010). "ZAP-70: an essential kinase in T-cell signaling." Cold Spring Harb Perspect Biol **2**(5): a002279.

Wang, S., H. Dong, J. Han, W. T. Ho, X. Fu and Z. J. Zhao (2010). "Identification of a variant form of tyrosine phosphatase LYP." BMC Mol Biol **11**: 78.

Wang, Y., I. Shaked, S. M. Stanford, W. Zhou, J. M. Curtsinger, Z. Mikulski, Z. R. Shaheen, G. Cheng, K. Sawatzke, A. M. Campbell, J. L. Auger, H. Bilgic, F. M. Shoyama, D. O. Schmeling, H. H. Balfour, Jr., K. Hasegawa, A. C. Chan, J. A. Corbett, B. A. Binstadt, M. F. Mescher, K. Ley, N.

Bottini and E. J. Peterson (2013). "The autoimmunity-associated gene PTPN22 potentiates toll-like receptor-driven, type 1 interferon-dependent immunity." Immunity **39**(1): 111-122.

Wange, R. L., R. Guitian, N. Isakov, J. D. Watts, R. Aebersold and L. E. Samelson (1995). "Activating and inhibitory mutations in adjacent tyrosines in the kinase domain of ZAP-70." J Biol Chem **270**(32): 18730-18733.

Wei, S. H., M. J. Miller, M. D. Cahalan and I. Parker (2002). "Two-photon imaging in intact lymphoid tissue." Adv Exp Med Biol **512**: 203-208.

Wesoly, J., A. H. van der Helm-van Mil, R. E. Toes, A. P. Chokkalingam, V. E. Carlton, A. B. Begovich and T. W. Huizinga (2005). "Association of the PTPN22 C1858T single-nucleotide polymorphism with rheumatoid arthritis phenotypes in an inception cohort." Arthritis Rheum **52**(9): 2948-2950.

Wickner, W. and R. Schekman (2008). "Membrane fusion." Nat Struct Mol Biol **15**(7): 658-664.

Williamson, D. J., D. M. Owen, J. Rossy, A. Magenau, M. Wehrmann, J. J. Gooding and K. Gaus (2011). "Pre-existing clusters of the adaptor Lat do not participate in early T cell signaling events." Nat Immunol **12**(7): 655-662.

Wong, L., S. A. Lieser, O. Miyashita, M. Miller, K. Tasken, J. N. Onuchic, J. A. Adams, V. L. Woods, Jr. and P. A. Jennings (2005). "Coupled motions in the SH2 and kinase domains of Csk control Src phosphorylation." J Mol Biol **351**(1): 131-143.

Woodman, P. G. (2003). "p97, a protein coping with multiple identities." J Cell Sci **116**(Pt 21): 4283-4290.

Woodside, D. G., A. Obergfell, A. Talapatra, D. A. Calderwood, S. J. Shattil and M. H. Ginsberg (2002). "The N-terminal SH2 domains of Syk and ZAP-70 mediate phosphotyrosine-independent binding to integrin beta cytoplasmic domains." J Biol Chem **277**(42): 39401-39408.

Wu, J., A. Katrekar, L. A. Honigberg, A. M. Smith, M. T. Conn, J. Tang, D. Jeffery, K. Mortara, J. Sampang, S. R. Williams, J. Buggy and J. M. Clark (2006). "Identification of substrates of human protein-tyrosine phosphatase PTPN22." J Biol Chem **281**(16): 11002-11010.

Yu, X., J. P. Sun, Y. He, X. Guo, S. Liu, B. Zhou, A. Hudmon and Z. Y. Zhang (2007). "Structure, inhibitor, and regulatory mechanism of Lyp, a lymphoid-specific tyrosine phosphatase implicated in autoimmune diseases." Proc Natl Acad Sci U S A **104**(50): 19767-19772.

Zhang, J., N. Zahir, Q. Jiang, H. Miliotis, S. Heyraud, X. Meng, B. Dong, G. Xie, F. Qiu, Z. Hao, C. A. McCulloch, E. C. Keystone, A. C. Peterson and K. A. Siminovitch (2011). "The autoimmune disease-associated PTPN22 variant promotes calpain-mediated Lyp/Pep degradation associated with lymphocyte and dendritic cell hyperresponsiveness." Nat Genet **43**(9): 902-907.

Zhang, W., Y. Shao, D. Fang, J. Huang, M. S. Jeon and Y. C. Liu (2003). "Negative regulation of T cell antigen receptor-mediated Crk-L-C3G signaling and cell adhesion by Cbl-b." J Biol Chem **278**(26): 23978-23983.

Zhang, Y. and H. Wang (2012). "Integrin signalling and function in immune cells." Immunology **135**(4): 268-275.

Zhernakova, A., P. Eerligh, C. Wijmenga, P. Barrera, B. O. Roep and B. P. Koeleman (2005). "Differential association of the PTPN22 coding variant with autoimmune diseases in a Dutch population." Genes Immun **6**(6): 459-461.

Zikherman, J., M. Hermiston, D. Steiner, K. Hasegawa, A. Chan and A. Weiss (2009). "PTPN22 deficiency cooperates with the CD45 E613R allele to break tolerance on a non-autoimmune background." J Immunol **182**(7): 4093-4106.

Appendix

LYP-CSK CO-IP

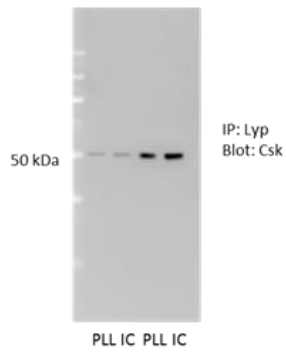
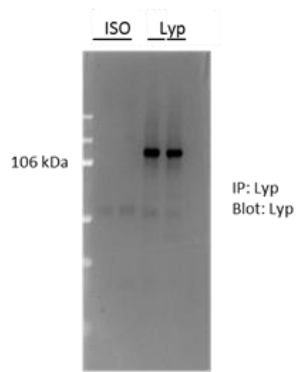

CSK-LYP CO-IP

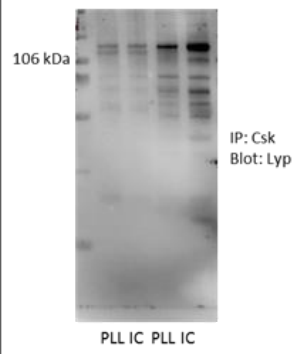
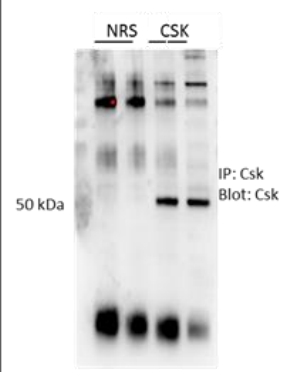

LFA-1-CSK-LYP CO-IP

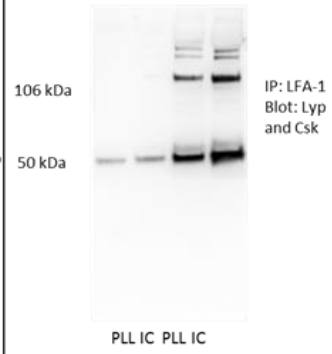
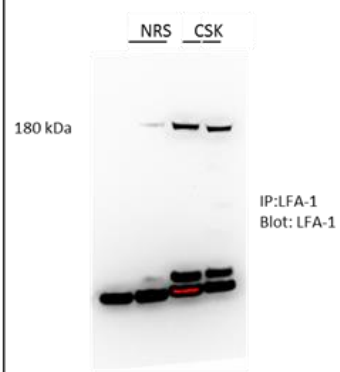

PAG-CSK CO-IP

