



King's Research Portal

DOI:

[10.1021/acs.chemrev.7b00343](https://doi.org/10.1021/acs.chemrev.7b00343)

Document Version

Peer reviewed version

[Link to publication record in King's Research Portal](#)

Citation for published version (APA):

Lauder, K., Toscani, A., Scalacci, N., & Castagnolo, D. (2017). Synthesis and Reactivity of Propargylamines in Organic Chemistry. *Chemical Reviews*, 117(24), 14091-14200. <https://doi.org/10.1021/acs.chemrev.7b00343>

Citing this paper

Please note that where the full-text provided on King's Research Portal is the Author Accepted Manuscript or Post-Print version this may differ from the final Published version. If citing, it is advised that you check and use the publisher's definitive version for pagination, volume/issue, and date of publication details. And where the final published version is provided on the Research Portal, if citing you are again advised to check the publisher's website for any subsequent corrections.

General rights

Copyright and moral rights for the publications made accessible in the Research Portal are retained by the authors and/or other copyright owners and it is a condition of accessing publications that users recognize and abide by the legal requirements associated with these rights.

- Users may download and print one copy of any publication from the Research Portal for the purpose of private study or research.
- You may not further distribute the material or use it for any profit-making activity or commercial gain
- You may freely distribute the URL identifying the publication in the Research Portal

Take down policy

If you believe that this document breaches copyright please contact librarypure@kcl.ac.uk providing details, and we will remove access to the work immediately and investigate your claim.

Synthesis and reactivity of propargylamines in organic chemistry

Kate Lauder, Anita Toscani, Nicolò Scalacci, and Daniele Castagnolo*

School of Cancer and Pharmaceutical Sciences, King's College London, Franklin-Wilkins Building, 150

Stamford Street, London, SE1 9NH, United Kingdom.

ABSTRACT

Propargylamines are a versatile class of compounds which find broad application in many fields of chemistry. This review aims to describe the different strategies developed so far for the synthesis of propargylamines and their derivatives as well as to highlight their reactivity and use as building blocks in the synthesis of chemically relevant organic compounds. In the first part of the review, the different synthetic approaches to synthesize propargylamines, such as A^3 couplings and C-H functionalization of alkynes, have been described and organized on the basis of the catalysts employed in the syntheses. Both racemic and enantioselective approaches have been reported. In the second part, an overview of the transformations of propargylamines into heterocyclic compounds such as pyrroles, pyridines, thiazoles and oxazoles, as well as other relevant organic derivatives, is presented.

CONTENTS

1. Introduction
2. Synthesis of propargylamines
 - 2.1. Nucleophilic addition of lithium acetylide to imines, oximes and nitrones
 - 2.1.1 Synthesis of racemic propargylamines from lithium acetylides
 - 2.1.2 Stereoselective addition of lithium acetylides to imines
 - 2.2. Synthesis of propargylamines using organomagnesium reagents
 - 2.3. Synthesis of propargylamines using aluminum acetylides
 - 2.4. Copper catalyzed synthesis of propargylamines

- 2.4.1 Copper(I) catalyzed alkynylation of imines and A³ coupling reactions
- 2.4.2 Copper(II) catalyzed alkynylation of imines and A³ coupling reactions
- 2.4.3 Copper catalyzed alkynylation of alkylamines
- 2.4.4 Copper catalyzed propargylic amination of propargyl esters
- 2.4.5 Copper catalyzed hydroamination reactions
- 2.4.6 Copper catalyzed retro-Mannich and deselenative C-H insertion reactions
- 2.4.7 Heterogeneous catalysis: solid-supported copper catalysts and copper nanoparticles
- 2.5 Zinc catalyzed synthesis of propargylamines
- 2.6 Gold catalyzed synthesis of propargylamines
- 2.7 Silver catalyzed synthesis of propargylamines
- 2.8 Iridium and rhodium catalyzed synthesis of propargylamines
- 2.9 Indium and zirconium catalyzed synthesis of propargylamines
- 2.10 Various metal catalyzed synthesis of propargylamines: nickel, iron, cobalt, bismuth, manganese
- 2.11 Synthesis of propargylamines using boronic acids and alkylboronates
- 2.12 Synthesis of propargylamines through metal-free reactions
- 2.13 Synthesis of propargylamines *via* aldehyde to alkyne homologation
- 2.14 Organocatalyzed synthesis of propargylamines
- 2.15 Biocatalyzed synthesis of propargylamines
- 3. Reactivity of propargylamines
 - 3.1. Synthesis of pyrroles from propargylamines
 - 3.1.1 Metal-catalyzed synthesis of pyrroles
 - 3.1.2 Miscellaneous metal free syntheses of pyrroles
 - 3.2 Synthesis of pyrrolines from propargylamines

- 3.2.1 Enyne metathesis reactions
- 3.2.2 Other approaches to pyrrolines
- 3.3 Synthesis of pyrrolidines from propargylamines
- 3.4 Synthesis of indoles and indole derivatives from propargylamines
- 3.5 Synthesis of pyrazines and pyrazoles from propargylamines
- 3.6 Synthesis of pyridines and pyridine derivatives from propargylamines
 - 3.6.1 Synthesis of pyridines
 - 3.6.2 Synthesis of dihydropyridines
 - 3.6.3 Synthesis of tetrahydropiperidines
 - 3.6.4 Synthesis of piperidines
- 3.7 Synthesis of quinolines and quinoline derivatives from *N*-propargylamines
 - 3.7.1 Synthesis of quinolines
 - 3.7.2 Synthesis of dihydroquinolines
 - 3.7.3 Synthesis of polycyclic quinoline derivatives
- 3.8. Synthesis of oxazoles, oxazolidinones and isoxazoles
 - 3.8.1 Base catalyzed synthesis of oxazoles
 - 3.8.2 Metal catalyzed synthesis of oxazoles
 - 3.8.3 Various approaches for the synthesis of oxazoles
 - 3.8.4 Synthesis of oxazolidinones
 - 3.8.5 Synthesis of isoxazoles
- 3.9 Synthesis of thiazoles and thiazolines from propargylamines
 - 3.9.1 Reactions of propargylamines with CS₂
 - 3.9.2 Reactions of propargylamines with isothiocyanates
 - 3.9.3 Synthesis of thiazoles/thiazolines from *N*-propargyl thioamides
- 3.10 Synthesis of imidazoles from propargylamines

- 3.11 Synthesis of imidazolidin-2-ones, imidazol-2-ones and imidazolidine-2-thiones from propargylamines
 - 3.12 Synthesis of triazoles from propargylamines
 - 3.12.1 Copper-catalyzed synthesis of triazoles from propargylamines
 - 3.12.2 Other metal-catalyzed synthesis of triazoles from propargylamines
 - 3.12.3 Metal-free synthesis of triazoles from propargylamines.
 - 3.13 Synthesis of other heterocycles from propargylamines
 - 3.14 Various metal-catalyzed transformations of propargylamines substrates
 - 3.14.1 Palladium-catalyzed Sonogashira reactions of propargylamines
 - 3.14.2 Palladium catalyzed synthesis of allenes from propargylamines
 - 3.14.3 Other palladium-catalyzed reactions of propargylamines
 - 3.14.4 Metathesis reactions of propargylamines
 - 3.14.5 Cobalt and titanium catalyzed Pauson-Khand reactions of propargylamines
4. Conclusions

1. INTRODUCTION

Propargylamines are a versatile class of compounds whose application in pharmacological and pharmaceutical chemistry has soared. A number of propargylamine derivatives such as pargyline,¹ rasagyline² and selegiline,³ have found direct application in the treatment of neurodegenerative diseases, such as Parkinson's⁴ and Alzheimer's diseases.⁵ Propargylamines are useful synthetic precursors in the manufacturing of different organic substrates, natural products and drugs as shown by the high number of papers reported in the literature.⁶⁻¹⁵

The first papers on the use of propargylamines go back to the 1940s-1950s¹⁶⁻¹⁸ and since then these unique organic compounds have been widely used as substrates in the synthesis of aliphatic and aromatic organic molecules, including a large number of heterocycles such as

oxazoles, imidazoles, pyrazoles and quinolines, through metal-catalyzed and cycloaddition reactions.

The versatility of this class of compounds is due to its unique structure comprised of an amine group in β -position to an alkyne moiety. Compounds with a carbon-carbon triple bond have characteristic reactivity and can behave both as electrophilic substrates and also as a source of electrons in nucleophilic reactions.¹⁹ In addition, the amine moiety of the propargylamine can undergo nucleophilic reactions, thus making this class of substrates susceptible to a variety of chemical transformations.

Despite the extensive use of propargylamines in organic synthesis, to the best of our knowledge, no comprehensive review describing both the synthesis and the reactivity of these interesting substrates has been reported in the literature so far. Therefore, a systematic review that clearly and exhaustively describes the different synthetic approaches as well as the reactivity of propargylamines in organic chemistry is highly desirable. This review covers the works reported in the last two decades and it is divided into two main parts, describing 1) the methods for the synthesis of propargylamines, and 2) the reactivity of propargylamines and their use as building blocks in the manufacturing of different organic compounds.

2. SYNTHESIS OF PROPARGYLAMINES

Structurally simple propargylamines can usually be synthesized by simple alkylation reactions such as amination of propargylic halides,²⁰ propargylic phosphates or propargylic triflates.²¹⁻²³ Alternatively, commercially available propargylamines and their *N*-substituted derivatives can be further functionalized through alkylation with a variety of alkyl halides as shown in the synthesis of many organic compounds and drugs, such as monoamine oxidase B (MAO-B) inhibitors²⁴ or inhibitors of Lysine Specific Demethylase 1 (LSD1).²⁵ Finally, another popular method for the functionalization of propargylamines is represented by

reductive amination reactions using aldehydes and ketones in the presence of both NaCNBH₃ or Na(AcO)₃BH as reducing agents.²⁶

Despite the high number of works reported in the literature on the synthesis of propargylamines *via* alkylation or amination reactions (Scheme 1. *reactions a-c*), these approaches will not be covered by this review, which will instead focus on more original, challenging and stereoselective synthetic methods. These include multicomponent reactions, metal-catalyzed enantioselective reactions, and oxidation reactions of tertiary amines. The main approaches that have been developed so far for the synthesis of propargylamines are summarized in Scheme 1 (*reactions d-h*). One of the most popular methods is represented by the stoichiometric addition of alkynyl nucleophiles to imines or enamines (*reaction d*).²⁷ Alkynyl nucleophiles are generally generated through the reaction of alkynes with metals (Li or Mg) and often require harsh reaction conditions (anhydrous conditions, low temperatures). In the last decades, the transition metal-catalyzed addition of alkynes to imines has become a more popular approach to synthesize propargylamines (*reactions e and f*). These methods proceed well through the use of a catalytic amount of a metal catalyst (i.e. Cu, Zn, Ag, Au etc.) under mild reaction conditions and green solvents.²⁸ Moreover, the development of multicomponent A³-coupling reactions (*path f*) allows the efficient assembly of propargylamines in a single step from a variety of aldehydes, amines and alkynes.²⁹ Finally, other popular approaches for the synthesis of propargylamines are the transition metal-catalyzed oxidative functionalization of tertiary amines (*reaction g*) and the metal catalyzed C-H and C-Hal functionalization of alkynes and alkyl halides (*reaction h*). These latter methods are less developed than the A³ coupling reactions, but found application in the synthesis of structurally simple propargylamines unsubstituted at C1. Within this review, the different methods used for the synthesis of propargylamines will be divided on the basis of

the metal catalyst used. Finally, other metal-free synthetic approaches as well as organocatalytic and biocatalytic methods will be described.

Scheme 1. Different approaches for the synthesis of propargylamines

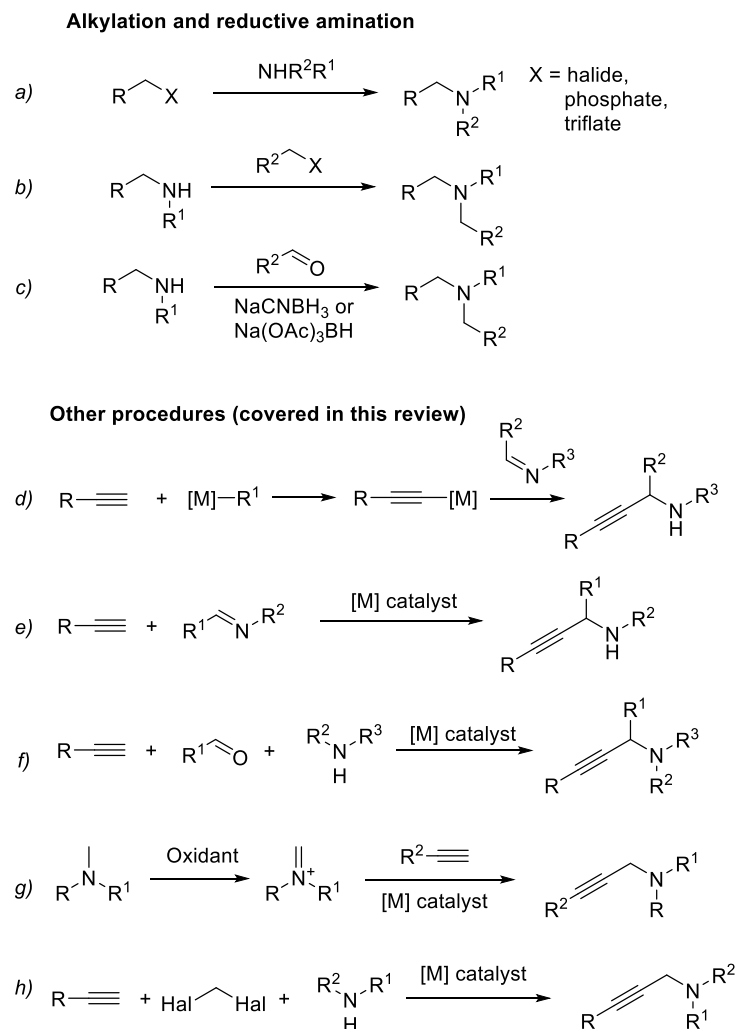

2.1. Nucleophilic addition of lithium acetylide to imines, oximes and nitrones

2.1.1 Synthesis of racemic propargylamines from lithium acetylides. The addition of lithium acetylide to imines is one of the most direct approaches to access racemic propargylamines bearing different substituents. The main limitation of this approach is generally represented by the harsh reaction conditions. These reactions often need to be carried out at low temperatures (-78 °C), and anhydrous solvents and inert atmosphere are

essential. Moreover, the lower reactivity of imine electrophiles, when compared to corresponding aldehydes/ketones, and the difficulties in the preparation and handling of lithium acetylides represent further limitations for this approach. Nevertheless, the use of lithium acetylides sometimes represents a valid method to access propargylamines and their derivatives. As an example, the addition of lithium acetylides **1** and **5** to oximes **2** and nitrones **4** has been reported by Rodriques³⁰ and Merino³¹⁻³² as shown in Scheme 2. The desired propargylamine derivatives **3** and **6** were obtained in high yields due to the high reactivity of the oxime and nitron substrates being more electrophilic than imines. Furthermore, the reaction of **4** with **5** showed high stereoselectivity and the hydroxylamine **6** was obtained mainly as the *syn* isomer. More recently, a similar approach for the synthesis of 4-ethynyl-*N*-hydroxy-2-imidazolidinones through the addition of lithium acetylides to oximes was reported by Pyerin and coworkers.³³ Despite the lack of selectivity of the one-pot addition/cyclization reaction, this study offers a good methodology for the synthesis of interesting alkynyl-substituted *N*-hydroxy-imidazolidinones.

Scheme 2. Addition of lithium acetylides to oximes and nitrones

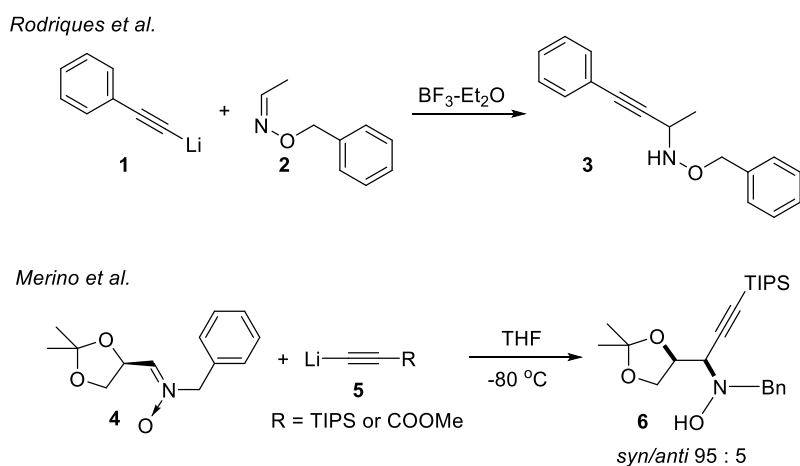

In general, an imine is a poor electrophile for the attack of lithium acetylides. However, electron deficient imines bearing electron withdrawing groups can be easily converted into

propargylamines by treatment with alkynyl lithium reagents. As an example, Burger and co-workers reported the synthesis of difluoro- and trifluoro-propargylamine derivatives as precursors in the synthesis of the fluorinated ornithine analogue **10**. The *N,N*-bis(trimethylsilyl)aminomethyl acetylide **8** was added to Boc- or Cbz-protected imines **7** in THF at low temperature to afford the desired compounds **9** in high yields (Scheme 3). In this case, the electrophilicity of the imine group was enhanced by its proximity to the electron withdrawing CF₃ and ester groups.³⁴ A similar approach has been later used by other authors for the synthesis of fluorinated arginine derivatives³⁵ and fluorine-containing α -alkynyl amino esters.³⁶ Magueur *et al.* also reported the synthesis of CF₃-propargylamines **13** via the addition of alkynyl lithiums to CF₃-substituted aldimines **11** (Scheme 3),³⁷ whilst Chen *et al.* described the synthesis of α -difluoromethyl α -propargylamines by adding lithium acetylides to fluorinated *N*-tert-butanesulfinyl ketimines.³⁸

Scheme 3. Addition of lithium acetylides to CF₃-substituted imines.

Osipov et al.

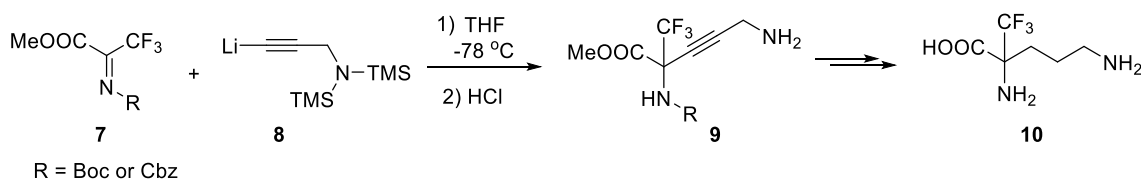

Magueur et al.

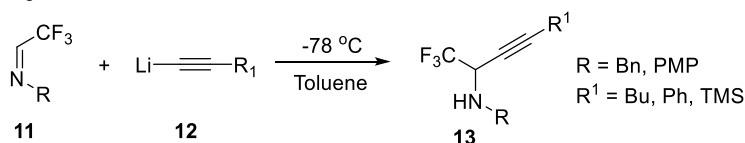

Organolithium reactions can be dramatically accelerated by adding BF₃·Et₂O to the reaction mixture. This also applies to the 1,2-additions of lithium acetylides to imines. In fact, Collum and co-workers investigated the BF₃-mediated additions of lithium phenylacetylide to the *N*-(*n*-butyl)imine **14**.³⁹ As shown in Scheme 4 the presence of BF₃·Et₂O has a dramatic effect on the outcome of the reaction leading to **15** in 70% yield. Importantly, yields are often much

higher if $\text{BF}_3\text{-Et}_2\text{O}$ is added to the substrate/organolithium solution or if the organolithium is added to a substrate/ $\text{BF}_3\text{-Et}_2\text{O}$ solution, whilst premixing of $\text{BF}_3\text{-Et}_2\text{O}$ and the organolithium is often, but not always, detrimental. Moreover, it has been demonstrated that the use of complexes like $\text{BF}_3\text{-}n\text{Bu}_3\text{N}$ may offer considerable advantages over $\text{BF}_3\text{-Et}_2\text{O}$ by precluding the aging effects associated with many BF_3 -mediated organolithium reactions.

Scheme 4. BF_3 -Mediated addition of lithium acetylides to imines.

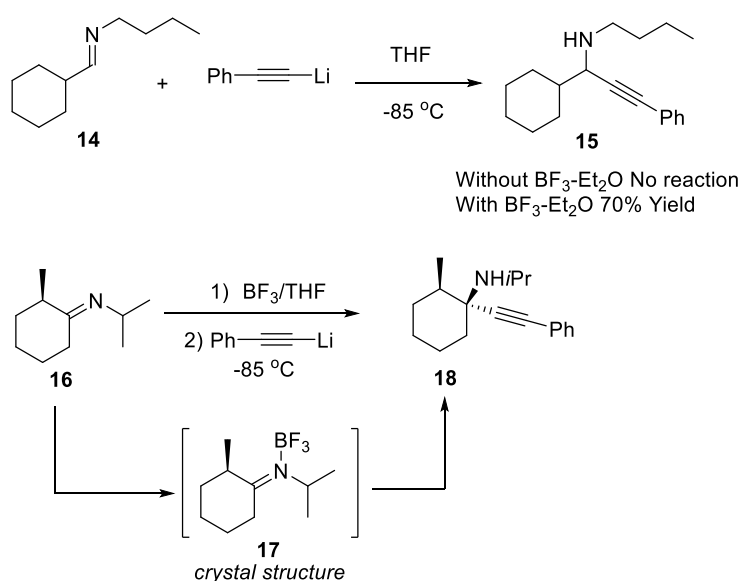

Subsequent studies on the BF_3 -mediated addition of lithium acetylides to imines showed that BF_3 -imine complexes are formed during the reaction and may be an important determinant of reactivity and selectivity. The crystal structure of the BF_3 -imine intermediate **17** in the synthesis of the propargylamine **18** (Scheme 4) has been reported.⁴⁰ Interestingly, from the stereochemical results and the crystal structures of the BF_3 -imine complexes reported in the literature, it seems that the allylic strain may strongly influence the reactivity of these substrates and therefore have an effect on the selectivity of the reaction. A similar example of alkylation of imines in the presence of $\text{BF}_3\text{-Et}_2\text{O}$ was later reported by Wee and Zhang.⁴¹ In order to overcome the poor reactivity of imines toward lithium acetylide addition, in 2005 Katritzky reported an interesting approach to access quaternary propargylamines through a lithium-mediated aminoalkylation of ketones.⁴² Treatment of a series of ketones **19** with

secondary amines **20** led to enamines **21**. Since these enamines **21** are poorly reactive towards the nucleophilic addition of lithium acetylides, they were treated with benzotriazole and converted into the benzotriazole adducts **22**. Since benzotriazole is a good leaving group that can be easily displaced by alkynyl lithium species, the treatment of the latter with an alkynyl lithium led finally to quaternary amines **23** in 30-98% yields (Scheme 5).

Scheme 5. Benzotriazole as leaving group in the synthesis of propargylamines

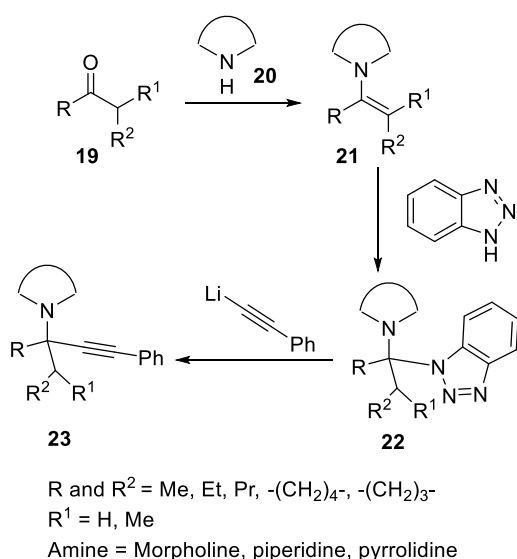

An alternative strategy to make the imine substrates more electrophilic is to bind an electron withdrawing group to the nitrogen. As an example, Qi *et al.* recently reported the synthesis of γ -amino-propargylamines **26** via the addition of lithiated ynamides to aryl imines **25** bearing a tosyl group on the nitrogen.⁴³ The presence of the electron withdrawing group on the imine nitrogen allows the substrate to be more electrophilic and therefore reactive towards the lithium nucleophile. The ynamide **24** was deprotonated with lithium hexamethyldisilazide (LHMDS) at -50 °C and the resulting acetylide was added *in situ* to the appropriate imine **25** to afford products **26** in excellent yields (Scheme 6).

Scheme 6. Addition of lithiated ynamides to N-tosyl-aryl imines.

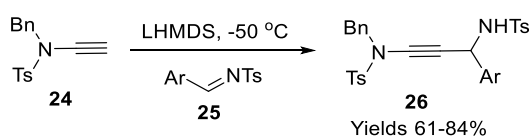

An interesting and different approach to propargylamines has been developed by Huang *et al.* who reported the one-pot transformation of secondary amides into secondary amines, including propargylamines. The one-pot treatment of the secondary amide **27** led to propargylamine **30** in 79% yield. The reaction proceeds according to Scheme 7. The reaction of Tf₂O with the amide leads to the formation of a highly electrophilic nitrilium ion intermediate **28**. The lithium alkyne reacts with CeCl₃ leading to an alkynylcerium intermediate which in turn reacts with **28** leading to the ketamine **29**. Reduction of **29** with NaBH₄ leads finally to the propargylamine **30**.⁴⁴

Scheme 7. CeCl₃ mediated one-pot transformation of secondary amides into propargylamines.

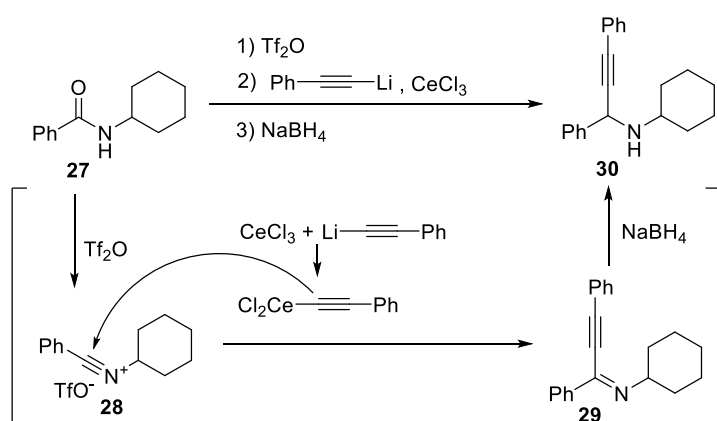

Later, the same authors reported a cerium-free modified approach to propargylamine **35**. The amide **31** was treated with Tf₂O affording the intermediate **32** which was immediately reduced *in situ* into the imine **33** by treatment with Et₃SiH. The formed imine was then activated by BF₃-Et₂O and reacted *in situ* with lithium acetylide to produce propargylamine **35** in good yields. Scheme 8.

Scheme 8. Cerium-free transformation of secondary amides into propargylamines

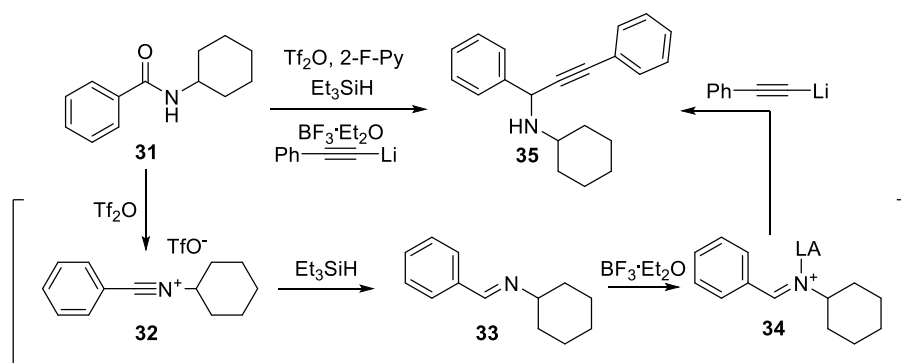

The authors applied this methodology also to the synthesis of non-aromatic amides retaining high yields.⁴⁵

Lithium mediated syntheses of propargylamines are generally based on the addition of stoichiometric amounts of lithium acetylides to imines. Within this context, it is worth mentioning a catalytic approach developed by Jeong and co-workers for the synthesis of propargylamines *via* a three-component coupling reaction of aldehydes, secondary alicyclic amines and alkynes (A^3 coupling). The multicomponent reaction was performed under solvent-free open air conditions with lithium triflate (LiOTf) used as catalyst. The authors postulated that the A^3 coupling reaction proceeds through the formation of a lithium acetylide intermediate by terminal alkyne **38** C–H bond activation. The formed lithium acetylide would then react with the iminium ion formed *in situ* from the coupling of the aldehyde **37** and the amine **36** leading to the corresponding propargylamine **39** and the releases of the LiOTf catalyst for further reactions.⁴⁶ Scheme 9. To date, no further investigations on the use of LiOTf in A^3 coupling reactions have been reported.

Scheme 9. Synthesis of propargylamine **39** using catalytic LiOTf.

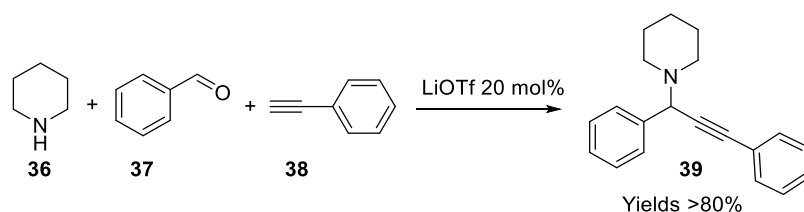

2.1.2 Stereoselective addition of lithium acetylides to imines. Although most of the stereoselective approaches for the synthesis of propargylamines rely on the C-H activation of alkynes with a catalytic amount of metal and their addition on imines/iminium ions, a few methods to access enantioenriched propargylamines using alkynyl lithiums have also been reported in the literature. One of the most used strategies is to exploit enantiomerically pure alkyl-*N*-sulfinyl imines (Ellman sulfinamides) as substrates.⁴⁷⁻⁴⁸ These imines possess high stereoselective reactivity due to the presence of the chiral electron-withdrawing *N*-sulfinyl group which exerts a powerful and predictable stereodirecting effect, resulting in high levels of asymmetric induction. Moreover, the *N*-sulfinyl group can be easily removed under acidic hydrolysis affording the corresponding unsubstituted propargylamines. As an example, Hou and co-workers first reported the synthesis of a variety of *N*-*tert*-butylsulfinylpropargylamines **42** in high yields and high diastereoselectivity through the addition of alkynyl lithium reagents, generated *in situ* by treatment of alkyne **41** with LiHMDS, on the enantiopure imine **40**.⁴⁹ Scheme 10. Harried *et al.* later exploited this approach to stereoselectively synthesize a set of propargylamines as precursors of 3-amino-1,2-epoxides.⁵⁰ Ellman finally used a modified approach to access amines **45**, using Me₃Al as ligand.⁵¹⁻⁵² Scheme 10. Although Me₃Al appears to only have a modest effect on the diastereoselectivity of the reaction, a significant drop in the yield was observed when Me₃Al was not used. In all cases the *syn* diastereoisomers were obtained as the major products.

Scheme 10. Stereoselective addition of lithium acetylides to Ellman sulfinamides.

Hou

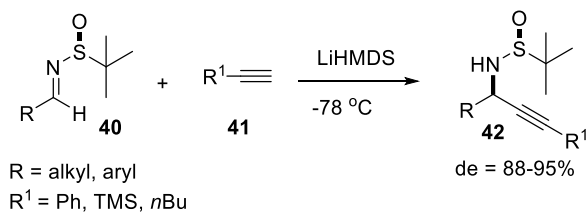

Patterson and Ellman

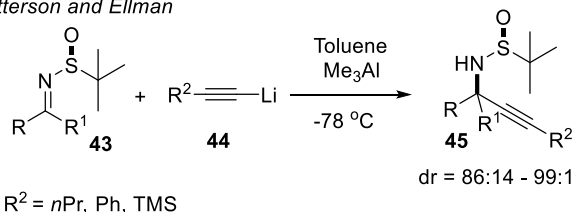

Another example of stereoselective synthesis of polyhydroxylated propargylamines **48** through alkylation of enantiopure imines **46** derived from (*R*)-glyceraldehyde was reported by Galvez and co-workers.⁵³ In this case, the imine does not bear any chiral electron withdrawing sulfoxide group and the diastereoselectivity is induced by the close proximity of the stereocentre to the imine moiety. Interestingly, the authors reported that the *syn/anti* diastereoselectivity of the addition reaction can be controlled and reversed by the appropriate use of Lewis acids as imine precomplexing agents (Table 1). When the lithium acetylide **47** was added to imine **46**, the *syn* product *syn-48* was obtained as the major isomer (*entry 1*). Similarly, the same diastereomeric ratio (dr) was observed when the reaction was carried out at the same temperature and in the presence of Et₂AlCl (*entry 2*). Interestingly, the addition of BF₃-Et₂O led to the formation of the other *anti* propargylamine isomer *anti-48* (*entry 3*).

Table 1. Addition of lithium acetylides to enantiopure imines 46.

Entry	Lewis acid	Temperature	<i>syn/anti</i> ratio

1	-	-30 °C	91:9
2	Et ₂ AlCl	-30 °C	91:9
3	BF ₃ -Et ₂ O	-30 °C	12:88

The stereochemistry of compound **48**, obtained in the absence of the Lewis acid or with the use of Et₂AlCl as a precomplexing agent, presumably arises as a result of the chelation control which leads to the preferential formation of the transition state A as shown in Scheme 11. On the other hand, the formation of the *anti* isomer in the presence of BF₃-Et₂O can be justified by the formation of a Felkin–Anh-type intermediate B.

Scheme 11. Distinguished stereoselectivity of the addition of **47 to imine **46**.**

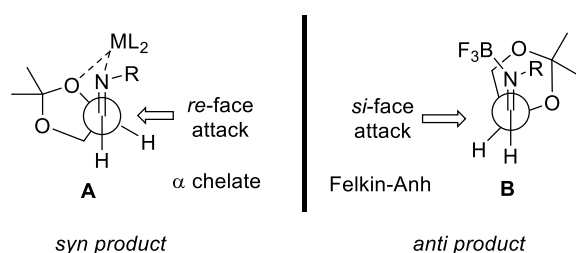

Chiral *N*-phosphonylimines **49** have been employed by Li and Pan in the stereoselective synthesis of a variety of substituted chiral propargylamines **51** through reaction with lithium aryl/alkyl acetylides. These latter species were generated *in situ* by treatment of terminal alkynes with LDA. The alkynyl lithium was then reacted with the chiral *N*-phosphonylimines **49** leading to propargyl derivatives **50** in high diastereomeric ratio. Acidic removal of the phosphonyl group leads to propargylamines/amides **51** (Scheme 12).⁵⁴

Scheme 12. Addition of lithium acetylides to chiral *N*-phosphonylimines.

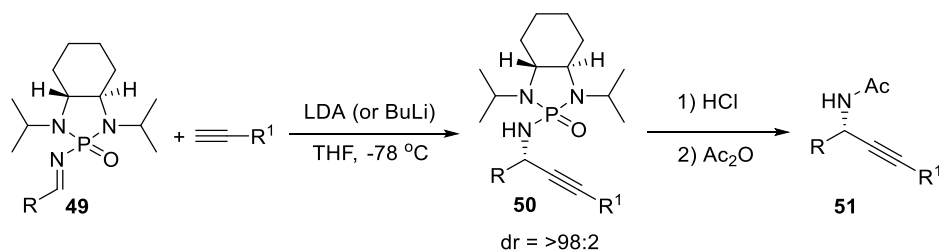

More recently, Poisson and co-workers described the addition of lithiated ynol ethers **53** to chiral *N*-sulfinyl imines **54** to afford chiral propargylamines **55** and **56** in high yield and diastereoselectivity. The lithium alkoxyalkynes **53** were generated *in situ* from dichloroenoethers **52** upon treatment with two equivalents of *n*-BuLi. Addition of the lithiated alkynes to **54** led to *N*-sulfinyl amine **55**. Interestingly, when the *N*-sulfinyl imines **54** were precomplexed with BF₃·Et₂O a complete inversion of selectivity was observed and amines **56** were obtained as major product (Scheme 13).⁵⁵ The chirality of the C1 stereocentre is reversed when BF₃·Et₂O is used, in agreement with the work of Galvez.⁵³

Scheme 13. Addition of lithiated ynol ethers to chiral *N*-sulfinyl imines.

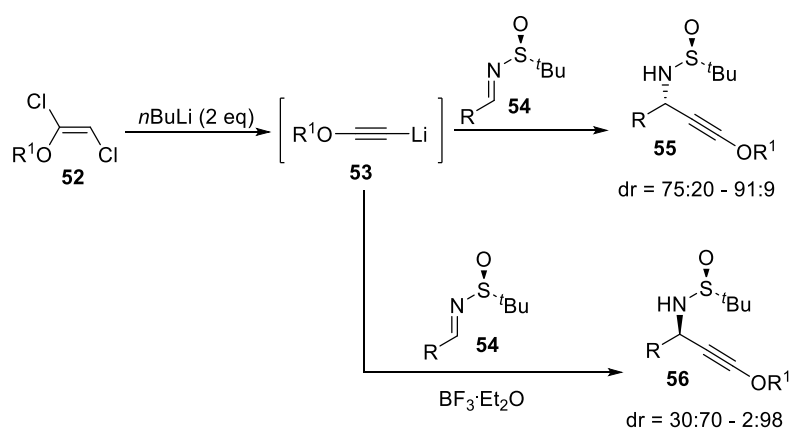

Similarly, Turlington reported a highly stereoselective addition of lithiated chloroacetylene **58**, derived *in situ* from *cis*-1,2-dichloroethene **57** and methyl lithium, to chiral *N*-tert-butanesulfinyl imines **59**. The reaction, shown in Scheme 14, led to **60** in high yield (up to 98%) and with excellent diastereoselectivity (up to >20:1) from a variety of aryl, heteroaromatic, alkyl, and α,β -unsaturated imine substrates. MeLi was found to be the best lithiating agent for the generation of the lithium acetylide **58**.⁵⁶

Scheme 14. Addition of chloroacetylene to chiral *N*-sulfinyl imines.

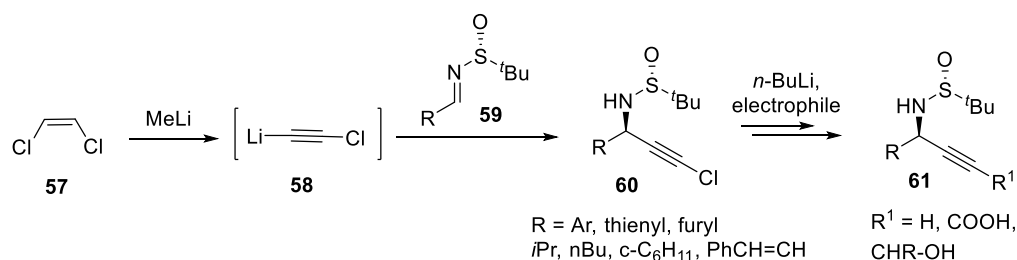

Finally, a noteworthy approach to cyclic *N*-methoxy propargylamines **63** has been described by Helmchen and co-workers, who reported the addition of lithium acetylides on *N*-methoxy lactams **62** followed by hydride reduction. The addition of the lithium acetylides on the amide leads to the formation of a hemiaminal intermediate, which is reduced *in situ* using NaCNBH₃ or NaBH₄ to afford compounds **63** with a high degree of stereoselectivity (Scheme 15).⁵⁷

Scheme 15. Addition of lithium acetylides on *N*-MeO-lactams.

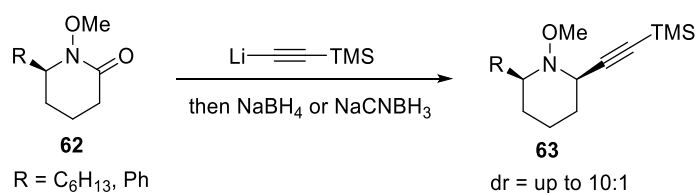

2.2. Synthesis of propargylamines using organomagnesium reagents

In a similar way to the addition of lithium acetylides to electrophilic imines, propargylamines can be also synthesized using Grignard reagents as nucleophiles in place of organolithiums. Grignard reagents are strong nucleophiles which may offer some advantages compared to the lithium nucleophiles concerning the reaction preparation, conditions, and storage of the reagents themselves. Most of the methods shown in the previous section can in principle be carried out successfully using an alkynylmagnesium halide in place of the lithium acetylide. For example, Burger and Sewald reported the synthesis of a series of amino acid derivatives with a propargylamine backbone by addition of alkylmagnesium chlorides to the imines **64**.

As previously shown, in order to have the nucleophilic attack of an organo-metal reagent on an imine substrate, the electrophilicity of the imines needs to be increased by the presence of an electron-withdrawing substituent, in this case the CF₃ and the methyl ester, on the C=N carbon (Scheme 16).⁵⁸ Similarly, electrophilic sulfinimines (Ellman sulfinimines) can be used as substrates for the synthesis of enantioenriched trifluoromethylpropargylamines **67**, through the addition of Grignard reagents to enantiopure sulfinimines **66**, as shown by Zanda and co-workers.⁵⁹ Kuduk *et al.* also used sulfinimines as substrates for Grignard additions. The authors described the synthesis of enantioenriched propargylamines **69** through the addition of propynylmagnesium bromide to 2-pyridyl *tert*-butyl sulfinimines **68** (Scheme 16). Interestingly, the propargylamine *anti*-**69** was obtained as major isomer, showing opposite selectivity in respect to the one observed in the addition of other organometallic reagents, such as BuLi.⁶⁰ The opposite stereoselectivity could be due to the formation of a complex between the magnesium, the sulfoxide and the pyridine ring, leading to a 6-membered transition state which drives the nucleophilic addition of the alkyne.

Scheme 16. Addition of Grignard reagents to imines.

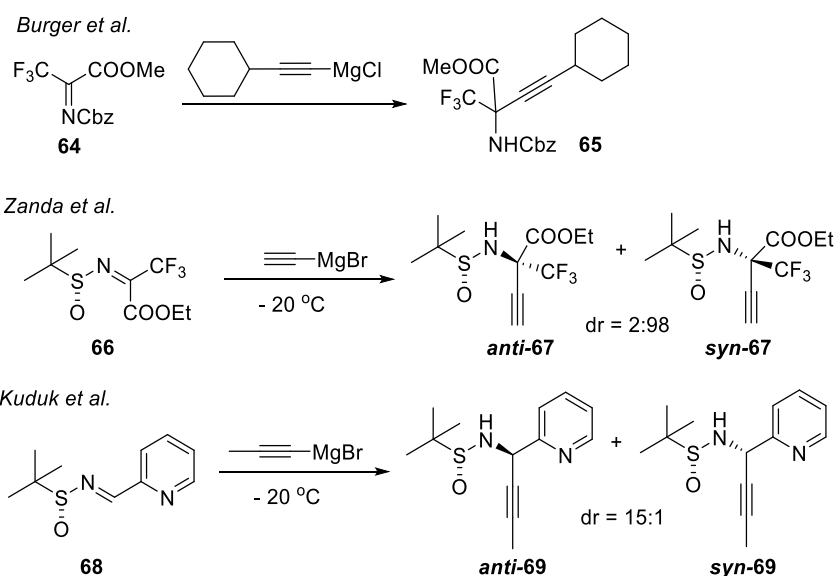

A highly diastereoselective addition of alkynylmagnesium halides to *N-tert*-butanesulfinyl aldimines has been reported more recently by Chen *et al.* A number of aldimines **70** were synthesized and sequentially treated with different alkynylmagnesium bromides affording the corresponding propargylamides **71** in high yields and excellent dr (>99:1 in most cases). Some examples are reported in Table 2.⁶¹ The sulfoxide group can then be easily removed to result in the corresponding propargylamine. Aryl sulfinylimines seem to be less reactive towards Grignard reagents (*entries 5-6 and 9-14*) and the corresponding amides **71** were obtained in lower yields.

Table 2. Addition of Grignard reagents to chiral *N-tert*-butanesulfinyl aldimines.

Reaction scheme: $\text{R}-\text{N}=\text{S}(\text{O})(\text{t-Bu}) \xrightarrow[\text{DCM, -78 } ^\circ\text{C to rt}]{2-3 \text{ eq. } \text{R}^1-\text{C}\equiv\text{C}-\text{MgBr}} \text{R}-\text{CH}(\text{NH}-\text{S}(\text{O})(\text{t-Bu}))-\text{C}\equiv\text{C}-\text{R}^1$

Entry	R	R ¹	Yield (%)	dr
1	<i>i</i> Pr	Ph	88	>99:1
2	<i>i</i> Pr	TMS	87	>99:1
3	<i>i</i> Pr	<i>n</i> Pr	88	>99:1
4	<i>tert</i> -Bu	<i>n</i> Bu	78	>99:1
5	Ph	TMS	46	>99:1
6	Ph	<i>n</i> Pr	45	>99:1
7	TBDPSOCH ₂	Ph	76	>99:1
8	TBDPSOCH ₂	TMS	73	>99:1
9	<i>p</i> -Cl-Ph	Ph	60	20:1
10	<i>p</i> -Cl-Ph	<i>n</i> Bu	79	13:1
11	<i>p</i> -NO ₂ -Ph	TMS	33	>99:1
12	Furanyl	TMS	45	>99:1
13	Furanyl	<i>n</i> Bu	70	25:1

A similar approach has been used by Zhang for the synthesis of chiral propargylamide precursors of azetidin-3-ones.⁶² As well as sulfinimines, alkynyl Grignard reagents can be added to nitrones as shown by Murga and Goti in the synthesis of a number of *N*-hydroxy-propargylamines. As previously shown with organolithiums, nitrones represent good electrophilic substrates for the nucleophilic addition of organometallic reagents.⁶³⁻⁶⁴

In order to make an imine more electrophilic, another possibility is to functionalize the C=N group with an electron withdrawing pyridine. Katritzky reported the synthesis of the propargylamine **75** through the addition of a Grignard reagent to a solid supported aldimine **73**. The 4-pyridine-carboxaldehyde **72** was condensed with Rink amine resin in trimethyl orthoformate to give polymer-bound aldimine **73**. The electron withdrawing effect of the pyridine ring makes the C=N bond more electrophilic and suitable for the nucleophilic addition of a Grignard reagent. The resin-immobilized aldimine **73** was reacted with phenylethyne magnesium bromide at 60 °C affording the corresponding supported propargylamine **74**, which was in turn converted into **75** after the cleavage with TFA (Scheme 17).⁶⁵

Scheme 17. Solid supported synthesis of propargylamine **75** with Grignard reagents

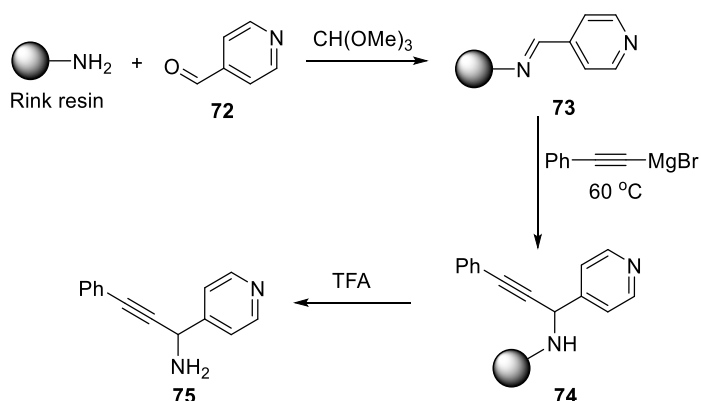

An interesting approach using Grignard reagents to synthesize the propargylamine **78**, a precursor of the orally-active GpIIb/IIIa antagonist FR184764, was reported by Yamanka

(Scheme 18).⁶⁶ The commercially available protected-hemiaminal 4-acetoxy-2-azetidinone **76** was used as the electrophilic substrate. Treatment of **76** with a Grignard reagent led to the cyclic propargyl lactam **77** which was then converted into the enantiomerically pure amine **78** through enzymatic kinetic resolution.

Scheme 18. Addition of Grignard reagents on hemiaminal 4-acetoxy-2-azetidinone.

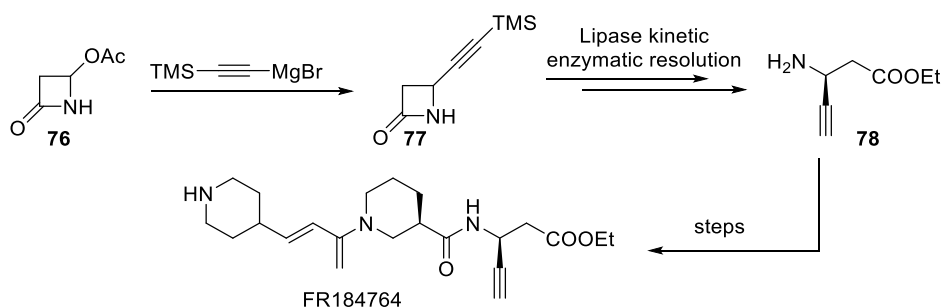

Nakamura *et al.* developed a general methodology for the synthesis of enantioenriched secondary amines through the nucleophilic addition of Grignard reagents to 2-pyridinesulfonylimines in the presence of chiral auxiliaries or appropriate Lewis acids (Scheme 19). Propargylamide **81** was synthesized through the addition of phenylethynylmagnesium bromide to **79** in the presence of the bisoxazoline **80**. The sulfonyl protecting group was then removed upon treatment with Mg in MeOH and the resulting propargylamine **82** was obtained with 78% enantiomeric excess (ee).⁶⁷

Scheme 19. Stereoselective synthesis of **81 with bisoxazoline chiral ligand.**

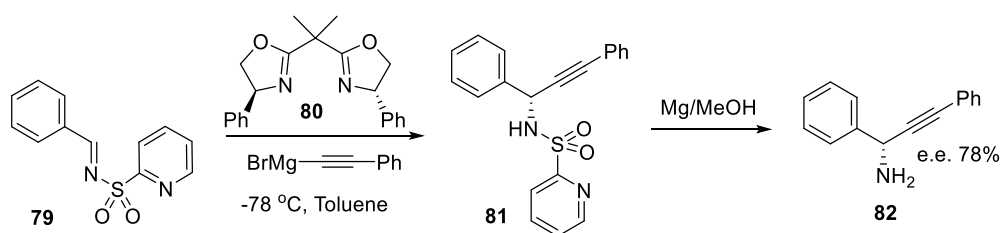

Very recently, a different approach to access propargylamines using Grignard reagents was reported by Maruoka. Grignard acetylenes were reacted with electrophilic *N*-Boc-aminals **83** at -20 °C, to afford propargylamines in high yields as shown in Table 3.⁶⁸ Interestingly, the

authors also tried to synthesize the propargylamine **87** from the alkynyl aminal **85**. However, the treatment of **85** with isopropylmagnesium chloride led to the corresponding amine in low yield and the *N*-Boc-imine intermediate **86** was reduced during the reaction. On the other hand, the addition of ZnCl₂ proved to be effective in suppressing this side reaction, leading to a significantly increased yield. Finally, the authors demonstrated that propargylamines can also be oxidized with MnO₂ and converted into the corresponding ketimines. These latter can be further treated with organolithium reagents leading to quaternary propargylamine derivatives.

Table 3. Addition of Grignard reagents to electrophilic *N*-Boc-aminals.

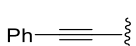
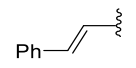
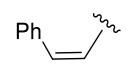
R	R¹	Yield (%)
	Bu	78
	Ph	82
	COOEt	74
	TMS	81
	Ph	84
	TMS	71
	Ph	84
	TMS	85

Finally, the work of Murai *et al.*, in which an alternative approach to propargylamines *via* sequential reactions of *in situ* generated thioiminium salts with organolithium and

organomagnesium reagents was reported, is noteworthy.⁶⁹ The authors found that it was possible to generate a thioiminium salt **89** through the reaction of a thioamide and MeOTf. The substrate **89** can be considered as a highly electrophilic acyl equivalent and is thus able to react with strong nucleophiles like organolithium and Grignard reagents. The treatment of the thioiminium with an alkynyl lithium and then an alkynyl Grignard reagent, afforded the propargylamine **91**, as shown in Scheme 20. Several propargylamines were obtained in 61-98% yields. It is interesting to note that if the thioiminium **89** is treated with the Grignard reagent first, no reaction occurs. Also the treatment of the propargylamine intermediate **90** with another equivalent of organolithium did not lead to the formation of any product. Thus, the only sequence which allows the formation of the propargylamine **91** is the addition of the organolithium followed by the Grignard reagent.

Scheme 20. Addition of lithium acetylides and Grignard reagents to thioiminium salts.

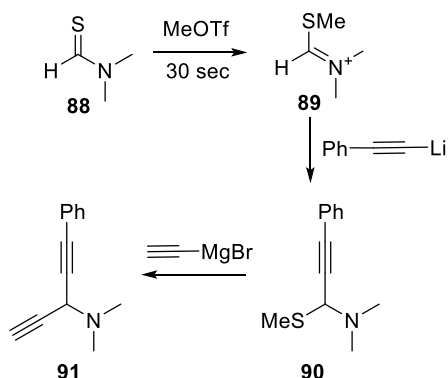

2.3 Synthesis of propargylamines using aluminum acetylides

Although aluminum acetylides are less popular than organolithiums or Grignard reagents, they have been used by some authors in the synthesis of propargylamines. Aluminum acetylides offer some advantages leading to desired products often in higher yields and reversed diastereoselectivities. In 1998, Katritzky and co-workers were the first to describe an interesting approach to propargylamines using sodium dialkynyl-diethylaluminates **93**. The

derivative **92** was used as electrophilic substrate due to the good leaving properties of the benzotriazole group. Reaction of **92** with different alkynylaluminates in toluene at room temperature afforded the corresponding propargylamines **94** in high yields as shown in Table 4.⁷⁰

Table 4. Addition of dialkynyl-diethylaluminates to benzotriazole derivatives 92

Entry	R	R ¹	R ²	R ³	Yield (%)
1	Ph	Me	H	Ph	91
2	Ph	Me	H	H	81
3	Et	Et	H	C ₅ H ₁₁	90
4	(CH ₂ CH ₂) ₂ O		H	Ph	90
5	Ph	Me	Ph	Ph	78
6	Ph	Me	Ph	H	60
7	(CH ₂ CH ₂) ₂ O		Ph	Ph	96
8	(CH ₂ CH ₂) ₂ O		Ph	H	82
9	H	Ph	Me	Ph	80

Later, the research group of Royer developed another approach to enantioenriched propargylamines exploiting aluminum acetylides. The authors compared the reactivity of standard lithium and magnesium acetylides with aluminum acetylides in the nucleophilic addition to sulfinimines.⁷¹ As shown in Table 5, excellent diastereoselectivity was obtained when alkynyldimethylaluminum reagents were used. Compound **97** was isolated in high yield and with excellent dr = 0.5:99.5 when the reaction was carried out at 0 °C in DCM (*entry* 7).

On the other hand, when Grignard or lithium acetylides were used under the same reaction conditions, only poor diastereomeric ratios were observed (*entries 1-4*). Remarkably, a complete reversal of diastereoselectivity was observed when aluminum acetylides were used in place of magnesium or lithium acetylides.

Table 5. Synthesis of enantioenriched propargylamines with aluminum acetylides.

Entry	M (Metal)	Conditions	Yield (%)	dr
1	MgBr	DCM, -78 °C to rt	65	65:35
2	MgBr	Toluene, -78 °C to rt	51	51:49
3	Li	DCM, -78 °C to rt	86	76:24
4	Li	Toluene, -78 °C to rt	86	82:18
5	Al(Me) ₂	DCM, rt	7	-
6	Al(Me) ₂	Toluene, rt	43	5:95
7	Al(Me) ₂	DCM, 0 °C	86	0.5:99.5
8	Al(Me) ₂	Toluene, 0 °C	85	2:98

The “alane model” of addition proposed by the authors is in accordance with the observed stereoselectivity, which is the reverse of the Ellman model for lithium acetylides. In the case of the alane addition, several equivalents (4 equiv. was optimum) of aluminum reagent need to be used. The mechanism suggested by the authors indicates that two different molecules of the organoaluminum reagent are chelated by both the nitrogen and the oxygen of the sulfinimines. Thus, an antiperiplanar disposition of these groups should result and explain the addition of a third reagent molecule on the less hindered *Si* face (Scheme 21). As a result of

this approach, several propargylamine derivatives have been synthesized and, in all cases, the *anti* diastereoisomer (*S,R*) was obtained as the major product with dr > 99:1.

Scheme 21. Alane model illustrating stereoselective addition to sulfinimines

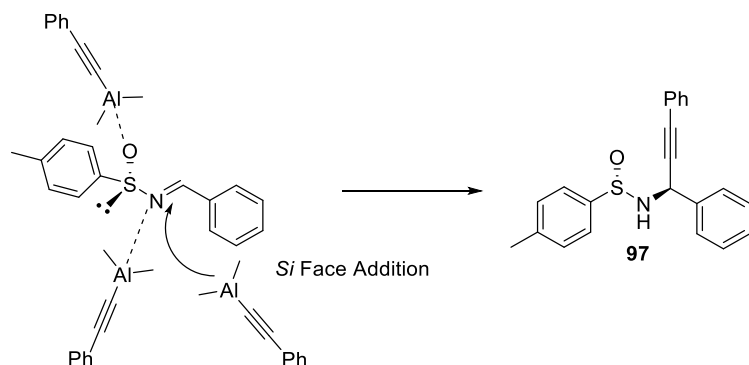

More recently, the same research group developed a new approach to enantioenriched propargylamines through the diastereoselective alkylation of chiral phosphinoylimines.⁷² The enantiopure (*S*)-methylphenylphosphinamide **98** was reacted with a series of aldehydes to afford the chiral phosphinoylimines **99**. Subsequent treatment with alkynyl alanes led to the desired propargylamines **100** with a dr > 90:10. Under the same reaction conditions and in the presence of lithium or magnesium acetylides, the compounds **100** were obtained in a lower dr. Table 6. The mechanism of the reaction was suggested to follow the “alane model”.

Table 6. Alkylation of chiral phosphinoylimines

Entry	M (Metal)	Conditions	Yield (%)	dr
1	MgBr	Toluene, rt	70	50:50
2	Li	Toluene, rt	-	-
3	Al(Me) ₂	Toluene, 1 h, rt	70	90:10

Another interesting diastereoselective approach to alkoxy-propargylamines using ethynylaluminum reagents has been recently described by Poisson and co-workers.⁷³ In this work, the 1,2-dichloroenoethers **101** were converted into the corresponding lithium organometallics **102** upon treatment with BuLi at $-78\text{ }^{\circ}\text{C}$, and **102** was in turn converted into the lithiated intermediate **103** upon heating to $-40\text{ }^{\circ}\text{C}$. The lithiated intermediate **103** was subsequently transmetalated by reaction with dialkylaluminum chloride at low temperature ($-78\text{ }^{\circ}\text{C}$) to generate *in situ* the dialkylaluminum alkoxyacetylide **104**. The latter was finally reacted with Ellman's sulfinylimines under mild reaction conditions (THF, $0\text{ }^{\circ}\text{C}$) affording a set of alkoxypropargylamines **106** in high dr. A six membered transition state, in which the imine is activated by complexation with two equivalents of aluminium acetylide, was proposed as shown in Scheme 22.

Scheme 22. Synthesis of alkoxy-propargylamines using ethynylaluminum reagents

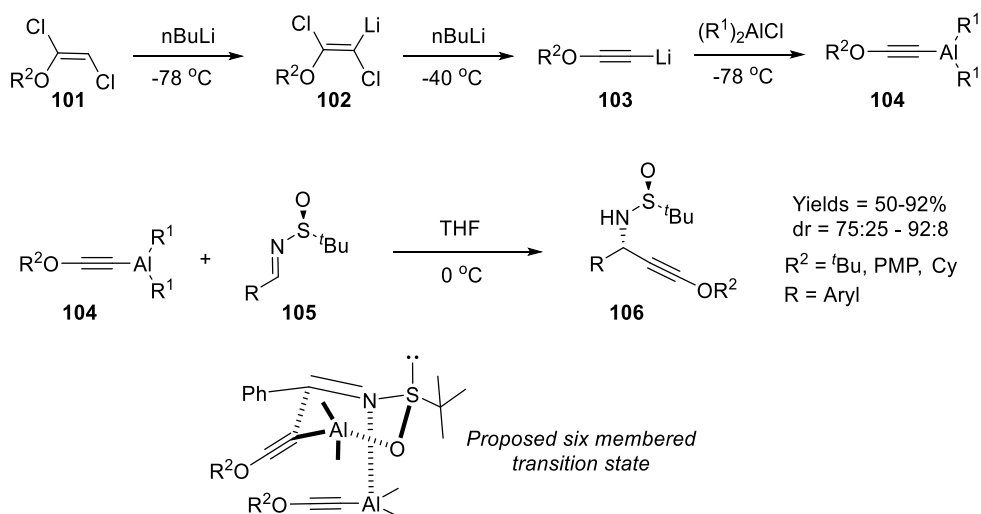

2.4. Copper catalyzed synthesis of propargylamines

Copper-facilitated reactions have a long history in organometallic chemistry, with new reactions continuing to be discovered and developed.⁷⁴⁻⁷⁷ Copper salts can act as catalytic cross-coupling agents, Lewis acids, and oxidizing agents. The relatively low cost of copper and the possibility to use it in catalytic amounts in many chemical transformations, makes it

an attractive reagent. Copper has a high affinity for π -bonds, in particular for alkynes, and promotes a variety of reactions such as addition reactions of heteroatoms to triple bonds, [3+2]-cycloadditions, and the addition of copper acetylides to electrophilic carbons.⁷⁸ Copper acetylides play an important role in the synthesis of a wide range of substrates and represent probably the most used method for the synthesis of propargylamines. The first copper acetylide Cu_2C_2 ($\text{Cu-C}\equiv\text{C-Cu}$) was proposed 1859,⁷⁹ and since then, a plethora of copper alkyne and alkyne compounds and intermediates have appeared in the literature. Both Cu(I) and Cu(II) salts and copper complexes have been used for the synthesis of propargylamines.

2.4.1 Copper(I) catalyzed alkylation of imines and A^3 coupling reactions. The Cu(I) catalyzed alkylation of imines was introduced by Li and co-workers in 2002,⁸⁰ and represents a general and efficient strategy for the synthesis of propargylamines.⁸¹ The authors treated easily accessible imines, generated *in situ* from the condensation of appropriate aldehydes with anilines and phenylacetylenes (A^3 coupling), with a Ru/Cu catalytic system. Initially, it was observed that different copper sources were able to promote the addition of alkyne **109** on imines **111** in moderate yield. Among the different copper sources tested, the CuBr led to the desired products **110** with the best yields. Next, the authors found that the addition of a catalytic amount of RuCl_3 (3 mol%) to the reaction mixture led to a dramatic increase in the yield (from 30% to 90%). The scope of the Ru/Cu-catalyzed reaction was then investigated by using a variety of imine substrates bearing aryl, naphthyl and *tert*-butyl substituents. The proposed mechanism shown in Scheme 23 illustrates the activation of the alkyne system by the Ru(III) salt. It has been hypothesised that the nucleophilic species is a Ru-acetylide rather than a copper acetylide. However, copper seems to have a key role in the reaction as it activates the imine and thus allows the nucleophilic attack of the Ru-alkynyl intermediate.

Scheme 23. Cu(I)-catalyzed A^3 coupling

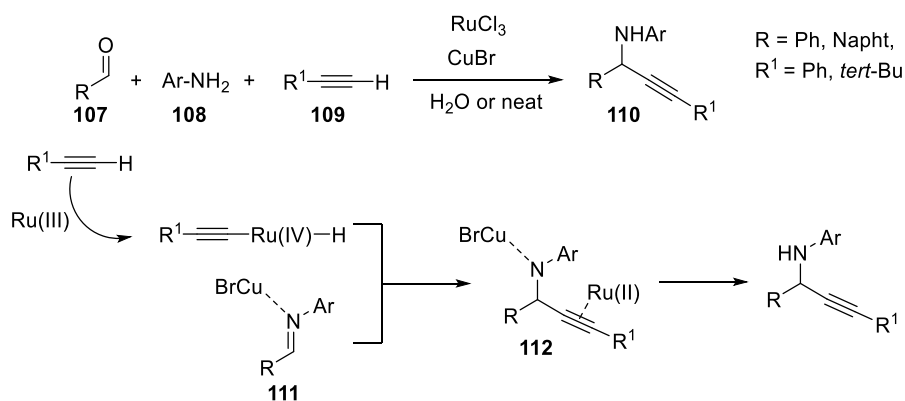

In parallel, Li also developed an enantioselective version of this reaction through the copper catalyzed addition of alkynes to imines (selected examples reported in Table 7). A PyBOX ligand **113** was used in combination with CuOTf to induce the stereoselectivity. In general, CuOTf proved to be a better copper source than CuBr, leading to >80% ee when the reaction was carried out in water. As shown in Table 7, higher ee were observed when the same reaction was carried out in toluene. Although it is noteworthy that no RuCl₃ was needed for the reaction to occur, the scope of this reaction seems limited to the use of substrates bearing aromatic substituents only. In this occasion, the PyBOX ligand forms a complex with Cu(I) which in turn activates the alkyne presumably leading to the formation of a copper acetylide intermediate.⁸²⁻⁸³ The ee were determined by HPLC analysis whilst the absolute configuration of one of the products was established by X-ray crystallographic analysis. Consequently, the absolute configuration of other products was correlated using the optical rotation direction and similar order of HPLC elution.

Table 7. Enantioselective A³ coupling with PyBOX ligand 113

Entry	R	Ar	Solvent	Yield (%)	ee (%)

1	Ph	Ph	H ₂ O	71	84
2	Ph	Ph	Toluene	78	96
3	4-Me-Ph	Ph	H ₂ O	86	81
4	4-Me-Ph	Ph	Toluene	85	92
5	4-Cl-Ph	Ph	H ₂ O	70	87
6	4-Cl-Ph	Ph	Toluene	85	94
7	2-Naph	Ph	H ₂ O	57	86
8	2-Naph	Ph	Toluene	63	88

Later, the coupling of alkynes with *N*-acylimines and *N*-acyliminium ions mediated by Cu(I) in water to generate propargyl amide derivatives was reported.⁸⁴

Following the initial work of Li and co-workers, several authors optimized the enantioselectivity of the copper-catalyzed addition reactions and expanded the substrate scope, using a Cu(I) complex of *i*-Pr-PyBOX-diPh ligand and Cu-(MeCN)₄PF₆ as copper source,⁸⁵ or a solid supported PyBOX catalyst.⁸⁶ The asymmetric alkynylation of imino esters **115** using CuOTf·0.5C₆H₆/PyBOX ligand (10 mol%) was described by Chan, who obtained propargylamine derivatives **117** with high ee up to 91% (Scheme 24).⁸⁷ It has been hypothesized that an intermediate **A**, in which the substrate **115** acts as the base in the formation of active Cu(I) alkynilide and as an electrophile through the activation by the Cu(I) ion and the terminal hydrogen of alkyne, is formed. Intermediate **A** is then converted into **B** *via* intramolecular proton and alkyne transfer. Subsequent decomplexation of **B** leads to the formation of final product **117**. The absolute configuration of these substrates was determined after reduction of the triple bond of **117** by comparison with known compounds.

Scheme 24. Alkynylation of imino esters using CuOTf·0.5C₆H₆/pybox ligand

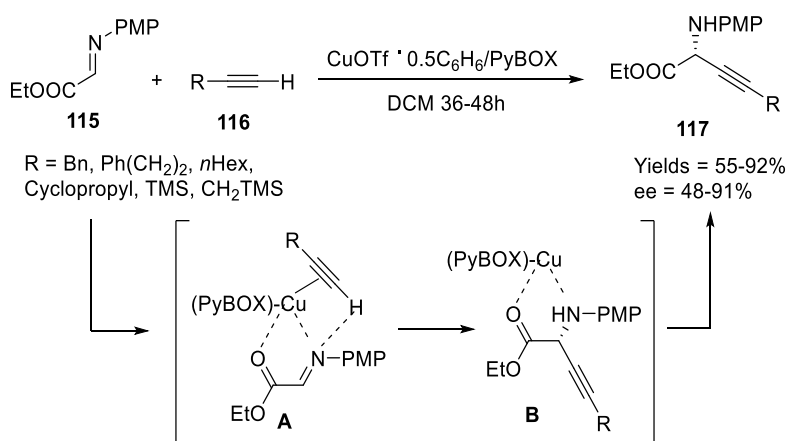

Benaglia *et al.* investigated a set of binaphthyl ligands **120-122** for the synthesis of the propargylamine **119**.⁸⁸ Table 8. The ligand **121** and **122** prove to be ineffective in catalyzing the synthesis of **119**, whilst ligands **120a-c** led to propargylamines with good ee and high yields. In particular, the ligand **120c**, bearing a pentafluoro-substituted phenyl ring, afforded **119** with 81% ee. The same group later expanded the scope of the reaction investigating different alkynes other than phenylacetylene. However, poor ee, determined by HPLC analysis, were observed when alkynes bearing non-aromatic substituents were used.⁸⁹⁻⁹⁰ The absolute configuration was assigned by comparison with literature data.⁸²

Table 8. Cu(I)-catalyzed synthesis of propargylamines with binaphthyl ligands

Ligands

120a Ar = Ph,
120b Ar = 2,6-diCl-Ph,
120c Ar = pentaF-Ph

Entry	Ligand	Solvent	Yield (%)	ee (%)
1	120a	Toluene	98	77

2	120b	Toluene	97	63
3	120c	Toluene	98	81
4	121	Toluene	-	-
5	122	Toluene	80	7

The copper-catalyzed synthesis of non-racemic propargylamines has been widely investigated and optimized by the research group of Knochel who reported first the addition of copper acetylides to enamines.⁹¹ The authors screened several metal and copper salts for their ability to promote the addition of metal acetylides to enamines, finding CuBr to be the most promising. The enantioselective version of the reaction was then investigated using (+)-QUINAP **125** (5 mol%) as a chiral ligand. A wide variety of substituted enamines **124** and alkynes **123** were used as shown in Table 9, leading to propargylamines **126** in excellent yields and high ee.

Table 9. Knochel's approach to enantiopure propargylamines

Entry	R ¹	R ²	R ³	Yield (%)	ee (%)
1	Ph	Pr	Bn	78	83
2	CH ₂ OMe	Pr	Bn	76	55
3	1-c-Hexenyl	Pr	Bn	84	74
4	CH ₂ CH ₃ CN	Pr	Bn	50	54
5	CH ₂ CH ₃ Cl	Pr	Bn	58	60
6	CH ₂ OTBDPS	Pr	Bn	85	72
7	TMS	Pr	Bn	73	86

8	Ph	Pr	Allyl	99	77
9	3-pyridyl	Pr	Bn	57	70

The reaction occurs through the formation of a $[\text{BrCu}(\text{QUINAP})]_2$ complex, which has been isolated and the structure determined by X-ray crystallography. The dimeric complex is supposed to dissociate into species **127** which, after successive complexation of alkyne **123** and enamine **124**, led to the zwitterionic intermediate **128**. The copper-complexed product **129** is then formed and the subsequent decomplexation produces the liberation of the propargylamine **126** and the regeneration of the catalyst. Scheme 25.

Scheme 25. Mechanism of Cu(I)-QUINAP catalyzed synthesis of 126.

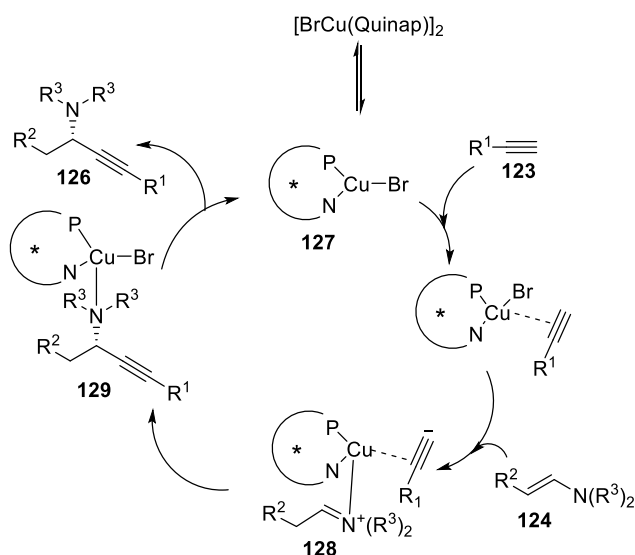

Later, a multicomponent variant of the copper catalyzed propargylamine synthesis, where iminium intermediates were generated *in situ* by the reaction of aldehydes and secondary amines and then reacted with copper acetylides, was described. Chiral propargylamines **129** were synthesized from a broad range of aldehydes, amines and ketones in the presence of the chiral auxiliary (*R*)-QUINAP **125** in high yields and with good-excellent ee, determined by chiral HPLC analysis.⁹² The alkyne and the aldehyde can bear both aryl or alkyl substituents and were reacted with diallyl- or dibenzylamines (Table 10).

Table 10. Cu(I)-QUINAP catalyzed A³ coupling

Entry	R ¹	R ²	R ³	Yield (%)	ee (%)
1	Ph	iBu	Bn	98	86
2	nBu	iBu	Bn	85	82
3	Ph	iPr	Bn	60	84
4	TMS	iPr	Bn	87	92
5	TMS	c-Hex	Bn	99	92
6	Ph	Ph	Allyl	91	70
7	Ph	<i>p</i> -MeOPh	Allyl	76	60
8	Ph	<i>p</i> -CF ₃ Ph	Allyl	43	63
9	c-Hex	3-Benzothiophenyl	Allyl	61	74
10	Ph	Furyl	Allyl	55	64

Mechanistic investigations carried out by the authors suggested that the dimeric Cu/QUINAP complex **131** is the catalytically active species. The proposed mechanism, illustrated in Scheme 26, envisages the reaction of the chiral copper/QUINAP complex with the alkyne **123** leading to the intermediate **132**, which in turn reacts with the hemiaminal **133** formed by the condensation of the amine and the aldehyde. The alkyne deprotonation leads to the formation of the copper acetylide **134**, which then selectively attacks the imine intermediate **135** leading to the generation of the enantioenriched propargylamine **130** and the regeneration of the copper/QUINAP catalyst.

Scheme 26. Mechanism of the Cu(I)-QUINAP A³ coupling

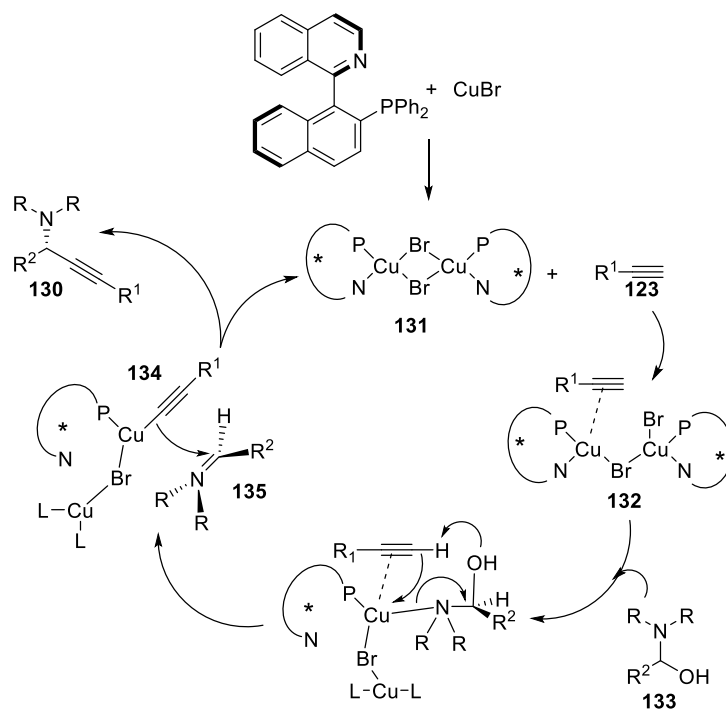

Following this work, a Cu/QUINAP catalyzed approach for the asymmetric one-pot three-component synthesis of propargylamines using the 2-phenallyl as a versatile protecting group of primary amines was also reported by Knochel. Propargylamines were obtained with ee of <96%. The 2-phenallyl protecting group can be removed with a Pd(0)-catalyzed allylic substitution using 1,3-dimethyl-barbituric acid as a nucleophile.⁹³⁻⁹⁴ A similar approach to enantioenriched propargylamines was also adopted by Carreira and co-workers, who replaced the QUINAP ligand with biaryl-P,N ligands (PINAP).⁹⁵ The authors observed that the Cu(I) complexes bearing the ligands **136a** and **136b** catalyze the formation of the *N*-dibenzyl propargylic amines **137** in 90–99% ee. Specifically, the ligand **136b** led to the formation of the (*R*)-enantiomer whilst the (*S*)-enantiomer was obtained when ligand **136a** was used (Scheme 27). The absolute configuration of **136a** was assigned unambiguously by X-ray structure analysis, whilst the absolute configuration of the products was compared with literature data.

Scheme 27. Carreira's approach to propargylamines using PINAP ligands

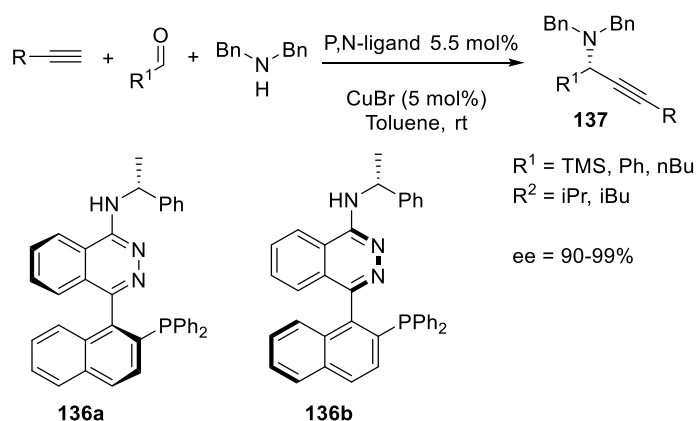

More recently, Carreira introduced the use of the 4-piperidinone fragment as a protecting group in the preparation of primary propargylamines. Trimethylsilylacetylene, aldehydes and 4-piperidone hydrochloride hydrate were mixed with $\text{CuBr}-(R,R)\text{-PINAP}$ affording enantioenriched propargylamines **138** in high yields and with excellent ee, determined by chiral GC or HPLC. Finally, the selective cleavage of the piperidinone protecting group, using the polymer-supported scavenger amine **139**, allowed the production and purification of the terminal primary propargylamines **140** through simple filtration (Scheme 28).⁹⁶ The use of 4-piperidone is original and allows the synthesis of primary propargylamines in a very efficient way. In fact, one of the limitation of many A^3 coupling reactions is represented by the need of secondary amine reagents, like dibenzylamines, to allow the formation of an electrophilic iminium intermediate. These couplings lead to *N*-dialkyl propargylamine products which cannot be easily converted into primary amines by standard cleavage (i.e. H_2/Pd) without affecting the triple bond. On the other hand, the method developed by Carreira proved to be effective in affording primary propargylamines **140** under mild reaction conditions and in high ee, especially when *n*-alkyl aldehydes were used as substrates. Nevertheless, when benzaldehyde was used as substrate, no satisfactory results were obtained, even under prolonged stirring, and the corresponding proaprgylamine was obtained in only 22% yield after 48 h.

Scheme 28. Synthesis of propargylamines using 4-piperidinone fragment as a protecting group

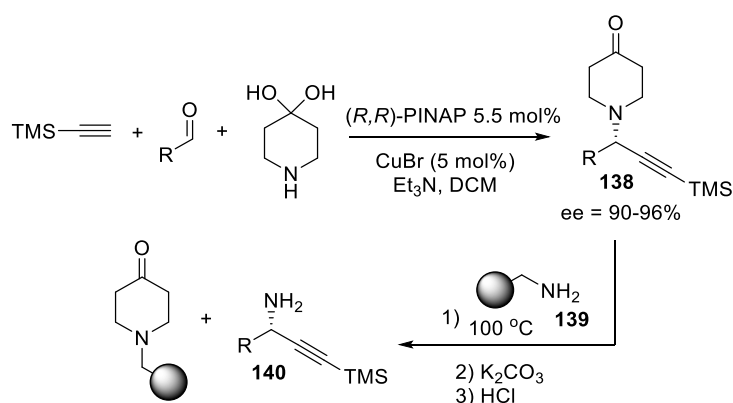

Another A^3 coupling synthesis using a PINAP analogue was later developed by Aponik and co-workers. The authors reported the synthesis and use of the imidazole-based chiral biaryl P,N-ligand **141** for the asymmetric synthesis of propargylamines **142**. The new ligand was designed with the aim to increase the rotational barrier in biaryl systems and was used in combination with CuBr in A^3 coupling reactions (Scheme 29).⁹⁷ The method proved to be very efficient and represents an improvement of previous PINAP mediated approaches as it allows also the synthesis of a variety of alkyl and aryl propargylamines. Interestingly, both aryl aldehydes bearing electron donating or electronwithdrawing substituents were converted into propargylamines in high yields and excellent ee.

Scheme 29. Aponik's PINAP ligand for the synthesis of 142.

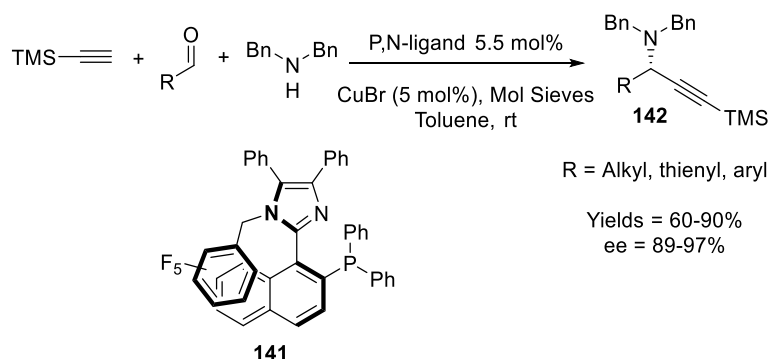

Chan and co-workers described another enantioselective approach to propargylamines by using the chiral *N*-tosylated aminoimine ligand **143**.⁹⁸ The results are summarized in Table 11.

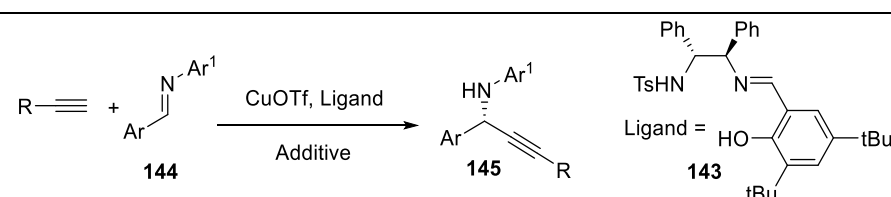
Table 11. Synthesis of propargylamines using the ligand 143.

The reaction scheme shows the synthesis of propargylamines **145** from imines **144** and alkynes $R-C\equiv CH$ using $CuOTf$ and a ligand. The ligand **143** is a chiral auxiliary with a $TsHN$ group and a 2,4,6-tri- tBu phenyl group.

Entry	Ar	Ar ¹	R	Additive	Yield (%)	ee (%)
1	Ph	Ph	Ph	-	41	63
2	Ph	Ph	Ph	MeONa	10	0
3	Ph	Ph	Ph	$tBuOK$	47	29
4	Ph	Ph	Ph	$nBuLi$	12	25
5	Ph	Ph	Ph	Et_3N	32	42
6	Ph	Ph	Ph	$Zn(Me)_2$	76	85
7	4-MeOPh	Ph	Ph	$Zn(Me)_2$	68	83
8	4-NO ₂ -Ph	Ph	Ph	$Zn(Me)_2$	73	87
9	4-Cl-Ph	4-Cl-Ph	Ph	$Zn(Me)_2$	65	91
10	4-MeO-Ph	4-MeO-Ph	Ph	$Zn(Me)_2$	63	83

The reaction of imine **144** with phenylacetylene led to the propargylamines **145** in low yield and ee (63%, *entry 1*). Some factors governing the enantioselectivities of the reaction were examined. The ee values obtained by the authors were found to be sensitive to the choice of solvent and temperature. Overall, the use of toluene at room temperature gave the best ee values. The use of an additive was also explored showing a dramatic increase of ee values when $Zn(Me)_2$ was added in stoichiometric amount to the reaction mixture. This significant increase is not accidental as the use of lower amounts of $Zn(Me)_2$ led to lower ee values. Several arylimines **144** were used as substrates which led to a variety of aryl-propargylamines **145** with 83-91% ee (*entries 6-10*). As clearly shown in Table 11, the scope of this reaction seems to be restricted to substrates bearing aromatic substituents. However,

the same authors later reported a copper-catalyzed alkynylation of α -imino esters with phenylacetylene using PyBOX ligand which led to propargylamine products in good yields with 67–74% ee.⁹⁹

A copper catalyzed approach for the synthesis of enantiopure propargylamines combining a Cu(I) catalyst with amino acid ligands was later described by Arndtsen. The idea behind this approach was that amino acids could bind the copper catalyst through hydrogen bonds and form an enantiopure metal complex. This latter provides an easy route for inducing both enantioselectivity in the chemical process (*via* the amino acid) and tunability which is often required in order to obtain high selectivity. Several imines **146** were thus reacted with phenylacetylene in the presence of a Cu(I) source, an amino acid and a ligand. The *N*-Boc-proline was found as the best amino acid for this reaction and CuPF₆ was chosen as Cu(I) source. Moreover, a variety of ligands were found to influence the enantioselectivity of the reaction, likely by changing the steric bulk of the copper catalyst. Overall, the use of the phosphine ligand P(*o*-tolyl)₃ in combination with *N*-Boc-proline leads to propargylamines **147** with the highest yields (Scheme 30).¹⁰⁰

Scheme 30. Arndtsen's approach to propargylamines using *N*-Boc-proline

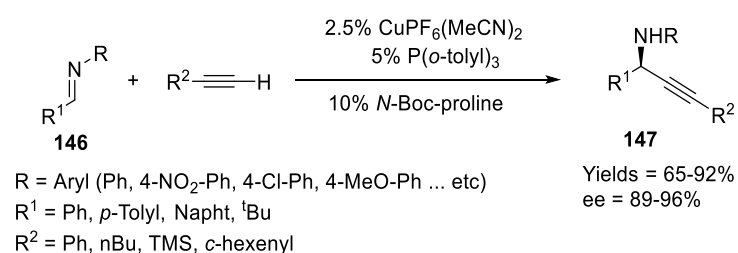

Nakamura and co-workers developed a three-component approach to propargylamines using the bis(imidazoline) PYBIM ligand **148** bearing two hydrophobic substituents. The multicomponent reaction of an aldehyde, an alkyne and PMP-NH₂ was carried out in water in the presence of CuOTf as catalyst and the sodium dodecyl sulfate (SDS) as surfactant. The use of SDS proved to be crucial for the yield and ee of the reactions. A series of

propargylamines, mainly bearing an aryl substituent at C1, was synthesized in excellent yields and with high ee using this approach. Curiously, the method also works when tap water or seawater were used as solvent. In both cases excellent ee were also observed.¹⁰¹ The mechanism is illustrated in Scheme 31. The substituent on the nitrogen atom of the imidazoline ligand **148** plays an essential role in influencing the yield of the products. In particular, the hydrophobic effect of the substituents on the imidazoline ligand and the copper salt are important for the formation of a colloidal dispersion and the enhancement of their reactivity. According to standard models adopted to explain the enantioselective alkynylation of imines by using a Cu(I) salt, it has been hypothesized that a copper–acetylide adduct is formed, which attacks the imine from the Si face to provide the (*R*)-propargylamine **149**.

Scheme 31. Nakamura's approach using a hydrophobic chiral catalyst **148.**

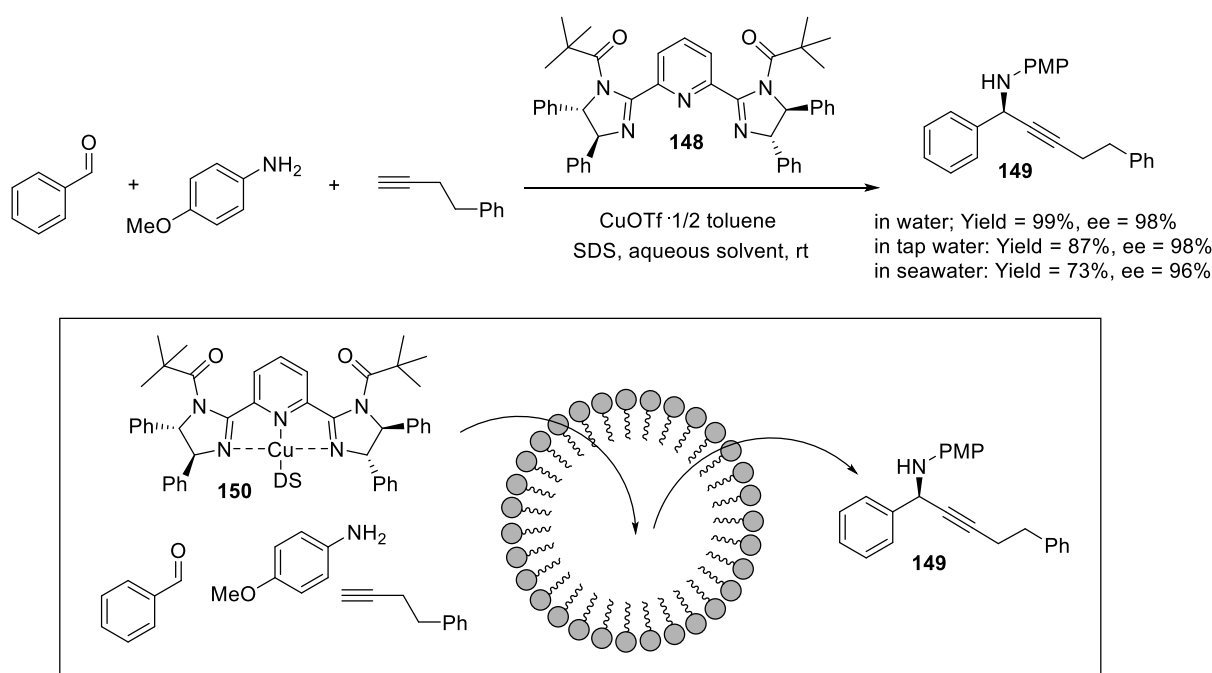

Following all of the above-mentioned studies, several authors reported variants of the copper-catalyzed alkynylation of imines. McDonagh *et al.* described the synthesis of *N*-aryl-propargylamines using a series of Cu(I) and Cu(II) complexes of two bis(oxazoliny)pyridines immobilized on silica *via* electrostatic interactions. The immobilized

catalysts showed an efficacy similar to that of their homogeneous catalyst equivalents leading to propargylamines with <85% ee when Cu(II) was used. Lower ee were observed with Cu(I) catalyst. The main advantage of the method is that the catalysts can be recycled several times whilst retaining their activity.¹⁰² Another asymmetric synthesis of propargylamines using a thioether-based Cu(I) Schiff base complex as a catalyst was carried out by Naeimi and Moradian. However, in spite of the high yields, the desired products were obtained with low ee values.¹⁰³ Seidel and co-workers described an enantioselective approach to propargylamines **151** via an A³ coupling reaction with a Cu(I)/acid–thiourea catalyst combination. The authors developed a new type of chiral Brønsted acid catalyst **152** containing both a carboxylic acid and a thiourea subunit.¹⁰⁴⁻¹⁰⁵ This catalyst series was designed with the notion that the thiourea moiety would function as an anion receptor, serving to stabilize the catalyst's conjugate base and thus increasing its Brønsted acidity. In particular, catalyst **152** emerged as a powerful cocatalyst of CuI in the A³ coupling reactions of alkynes, aldehydes and secondary amines, representing an efficient alternative to the QUINAP and PINAP approaches developed by Knochel and Carreira. A plethora of enantioenriched propargylamines **151** were synthesized in 80-95% ee (Table 12).¹⁰⁶ The authors observed that, in order to have optimal enantioselectivity, the use of 5 Å molecular sieves was absolutely vital, as reactions performed in the absence of either molecular sieves or other dehydrating agents gave inferior results. Moreover, higher selectivities were obtained when CuI was used in slight excess over the cocatalyst **152**. The absolute configuration of compound **151** bearing a naphthyl group at C1 and a 4-Br-Ph substituent on the triple bond (*entry 12*) was assigned by X-ray analysis whilst the configuration of all other compounds was assigned by analogy.

Table 12. A³ coupling reaction with Cu(I)/acid-thiourea catalyst **152.**

Entry	R	R ¹	Amine	Yield (%)	ee (%)
1	Ph	Ph	Pyrrolidine	92	92
2	Ph	4-Cl-Ph	Pyrrolidine	90	92
3	Ph	4-MeO-Ph	Pyrrolidine	90	96
4	Ph	Naphtyl	Pyrrolidine	96	94
5	Ph	<i>n</i> Butyl	Pyrrolidine	96	73
6	4-F-Ph	Ph	Pyrrolidine	86	93
7	<i>t</i> Butyl	Ph	Pyrrolidine	80	88
8	<i>n</i> Octyl	Ph	Pyrrolidine	91	92
9	Ph	Ph	Cycloheptylamine	80	88
10	Ph	Ph	Piperidine	95	68
11	Ph	Ph	Tetrahydro isoquinoline	95	61
12	4-Br-Ph	Naphtyl	Pyrrolidine	94	94

Periasamy and co-workers developed a CuBr-promoted diastereoselective synthesis of chiral propargylamine derivatives using 1-alkynes, aldehydes and enantiopure dialkylaminomethylpyrrolidine **153**. The propargylamines **156** were obtained in good yields and with excellent diastereoselectivity.¹⁰⁷ It has been hypothesized that the chiral diamine **153** would initially form a dimeric copper complex with CuBr, which would then react with 1-alkyne **155** to give a copper acetylide intermediate as shown in Scheme 32. The pyrrolidine nitrogen would form also iminium ion *in situ* by reaction with aldehyde **154**. Finally, the

alkyne would attack the iminium carbon on the opposite face of the pyrrolidine substituent affording **156** with high ee.

Scheme 32. CuBr-promoted synthesis of propargylamine from dialkylaminomethylpyrrolidine.

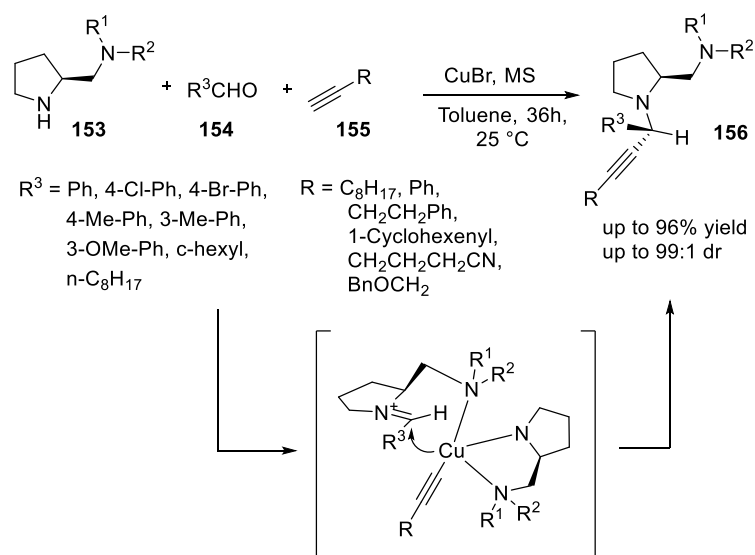

Alternative approaches to propargylamines include a copper-catalyzed three-component coupling of aldehydes and alkynes using hydroxylamines as nitrogen substrates¹⁰⁸ and A^3 coupling reactions using CuCl as catalyst to access propargylamine precursors of natural alkaloids.¹⁰⁹ An easy approach to propargylamines *via* a CuI-catalyzed three-component coupling reaction with succinic acid as an additive was reported by Ren *et al.*. The authors hypothesized that the A^3 coupling reaction is driven by the formation of a succinic acid complex with the Cu(I). Several dicarboxylic acids were screened as additives showing a correlation between the length of the dicarboxylic acid chains and the yield of the reaction.¹¹⁰ Chen and Liao reported the preparation of a dicopper(I) complex called $\text{Cu}_2(\text{pip})_2$ (pip = (2-picolyliminomethyl)pyrrole anion) that was used for the synthesis of propargylamines *via* A^3 coupling reactions. A variety of propargylamines were synthesized with a low catalyst loading of 0.4 mol% and in high yields.¹¹¹

An interesting alternative approach to propargylamines has been recently developed by Lee and co-workers (Scheme 33),¹¹² who used the aryl alkynyl carboxylic acids **157** as alkyne source. In the presence of CuI, **157** is decarboxylated leading to the formation of CO₂ and the copper acetylide **162**. The latter reacts with the iminium species **161** formed *in situ* by premixing appropriate aldehydes and amines. This protocol leads to the preparation of the propargylamines **160** in high yields.

Scheme 33. Synthesis of propargylamines from alkynyl carboxylic acids.

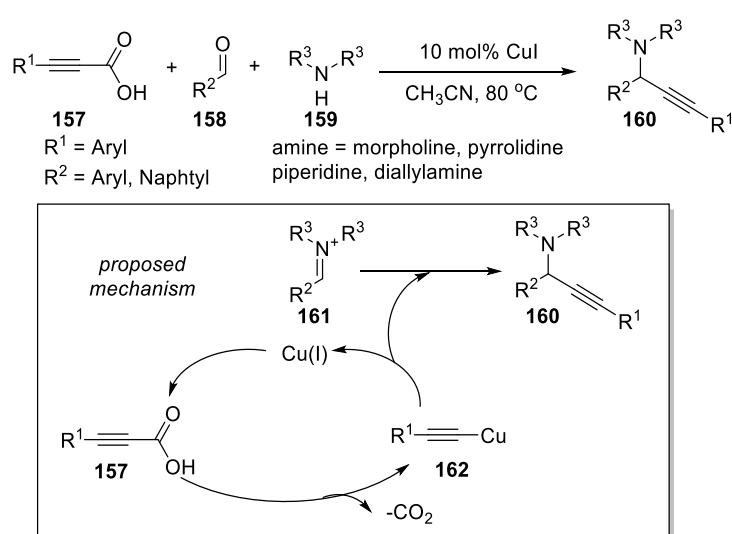

2.4.1.1 Mannich reactions. When the aldehyde used in the A³ coupling is formaldehyde, or a Schiff base is pre-formed as intermediate, it is possible to refer to these reactions as Mannich reactions. A non-catalytic early example to access propargylamines via Mannich reaction was reported by Youngman *et al.* in 1997.¹¹³⁻¹¹⁴ The authors developed a solid-phase copper-mediated synthesis of propargylamines **166** using a resin-bound piperazine substrate **164**. The commercially available 2-chlorotrityl chloride resin **163** was treated with piperazine and converted into **164**. The latter was reacted with different aldehydes, including paraformaldehyde, and aryl alkynes in the presence of CuCl. The alkynes behaved as the

"hydrogen-active" Mannich partners when reacted in the presence of CuCl. The solid support was finally cleaved with TFA yielding the desired propargylamines **166** (Scheme 34).

Scheme 34. Solid-phase copper-mediated synthesis of propargylamines.

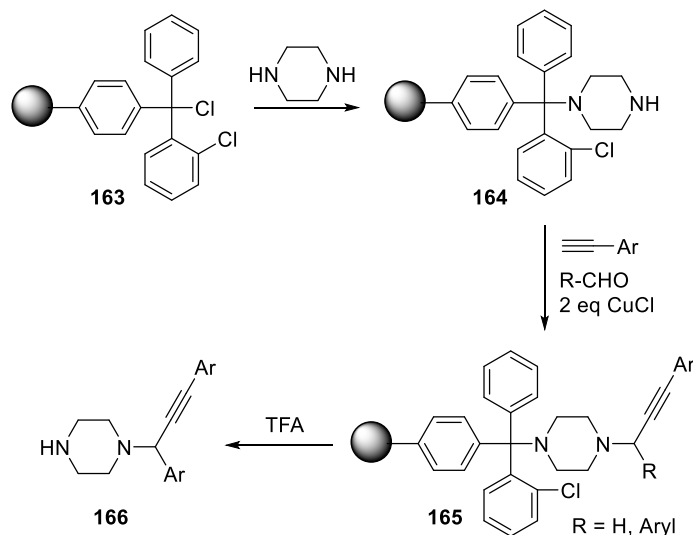

In 2004, Bieber reported a Mannich reaction catalyzed by CuI for the synthesis of a variety of propargylamines **167**. Several amines were reacted with different alkynes and formaldehyde to afford compounds **167** in excellent yields (Table 13). Several Cu(I) salts were also screened and CuI was found to be the best catalyst.¹¹⁵

Table 13. CuI catalyzed Mannich reaction.

Entry	R	R ¹	R ²	Yield (%)
1	Me	Me	Ph	95
2	(CH ₂) ₄		Ph	92
3	(CH ₂) ₅		Ph	98
4	Ph	Me	Ph	93
5	Bn	H	Ph	72

6	Me	Me	nBu	86
7		(CH ₂) ₄	nBu	96
8	Et	Et	CH ₂ OH	87
9		(CH ₂) ₄	CH ₂ OH	70
10	Me	Me	TMS	71

Additional works have been reported by Matsubara and co-workers who demonstrated that the use of a catalytic amount of an imidazole ligand could be beneficial in improving the yield of copper-catalyzed Mannich reactions,¹¹⁶ and by Wu and co-workers who reported the CuCl catalyzed synthesis of macrocyclic compounds possessing propargylamine skeletons.¹¹⁷

2.4.1.2 A³ coupling reactions in ionic liquids and other solvents. Ionic liquids are widely used in organic chemistry due to their numerous attractive properties, such as chemical and thermal stability, non-flammability, high ionic conductivity, and a wide electrochemical potential window. They have been extensively employed as solvents or, in some cases, as co-catalysts in various reactions including organic catalysis, inorganic synthesis, and polymerization processes. Ionic liquids have also been used in the development of efficient methods for the synthesis of propargylamines. Yadav *et al.* first reported the one-pot coupling of aldehydes, amines and alkynes using Cu(I) bromide immobilized in [bmim]PF₆ ionic liquid. It is worth noting that the reaction was also successful when primary amines, usually less reactive than secondary amines, were used as substrates yielding a series of secondary propargylamines in >80% yields.¹¹⁸

Later, Park and Alper described an efficient copper catalyzed synthesis of propargylamines *via* an A³ coupling in ionic liquids.¹¹⁹ The authors used [bmim]PF₆ as a solvent and screened several copper catalysts (CuI, CuBr, CuCl, CuCN, Cu(OAc)₂ as well as Cu powder. CuI and CuCN showed similar catalytic activity and, noteworthy, the catalysts were recycled and

reused for five or ten runs with only a slight drop in activity. A plethora of propargylamines were synthesized using this approach in excellent yields.

Finally, PEG-400 has also been employed by Zhang *et al.* as a solvent in A³ coupling reactions for the synthesis of propargylamines with CuI as catalyst. A wide range of propargylamines with yields ranging from moderate to excellent was obtained and the catalyst system was recovered and reused several times without evident loss in activity.¹²⁰

2.4.1.3 Microwave assisted A³ coupling reactions. An interesting example of microwave-assisted three-component A³ coupling to generate propargylamines **168** was reported by Tu and co-workers in 2004. The coupling reaction was performed in water and CuI was used as catalyst as shown in Scheme 35.¹²¹ Products **168** were obtained in a few minutes and high yields.

Scheme 35. Microwave assisted copper catalyzed synthesis of propargylamines 236.

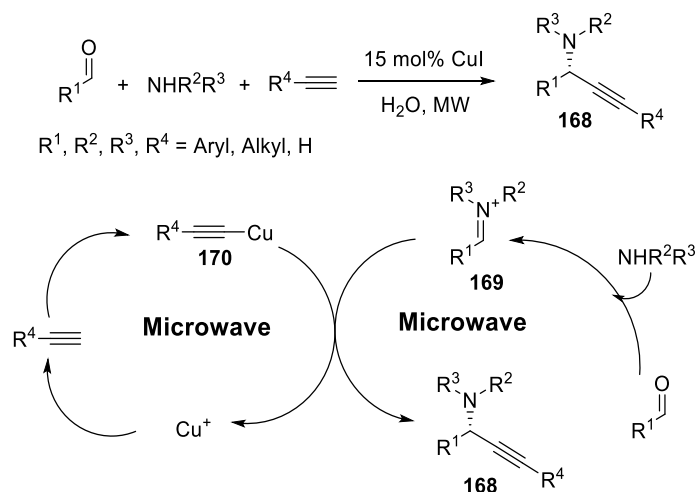

Microwave (MW) irradiation had a dramatic effect in accelerating the rate of the reaction. Under conventional heating conditions and without microwave irradiation, the three component A³ coupling required more than five days to reach completion, whilst the two-component coupling of phenylacetylene with the pre-made iminium intermediate **169** in the presence of 15 mol% CuI took six days. These facts indicated that MW irradiation is

necessary for speeding up both the A^3 coupling and the separate formation of alkynylcopper intermediate **170** and iminium **169**.

An additional microwave approach to yield propargylamines has been recently reported by Van der Eycken who described the efficient three-component reaction between an aldehyde, a primary amine and an alkyne using different copper catalysts. Propargylamines **171** were first synthesized in high yields *via* A^3 coupling at 100 °C in toluene using CuBr 20 mol%. The reaction proved to be fast and was completed in only 25 minutes.¹²² Later, the same group developed a greener approach where propargylamines **171** were synthesized using an cheaper Cu(I)/Cu(II) catalytic system in water. The combination of Cu(I) and Cu(II) catalysts gave higher yields than the single catalysts and the propargylamines were obtained in high yields at 110 °C (Scheme 36). Van der Eycken's approach is particularly noteworthy as it represents one of the few examples to access secondary propargylamines *via* A^3 coupling.¹²³

Scheme 36. Microwave assisted A^3 and KA^2 coupling reactions.

Van der Eycken microwave approach

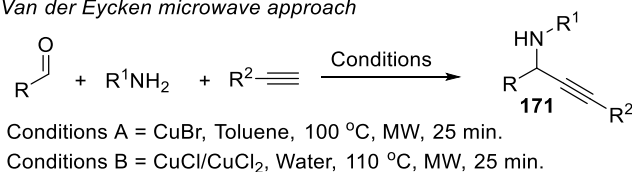

KA² coupling

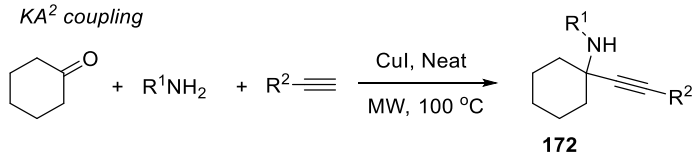

Interestingly, Van der Eycken and co-workers also described the multicomponent coupling of a ketone with a primary amine and an alkyne (KA^2 coupling) catalyzed by CuI in absence of solvent under microwave irradiation, to obtain a series of spiro-propargylamines **172** (Scheme 36). When cyclohexanone was reacted with PMP-NH₂ and phenylacetylene under conventional heating, the corresponding propargylamine was obtained in 59% yield after 20

hours. On the contrary, the same reaction carried out under microwave irradiation led to the same product after only 25 minutes and in 76% yield.¹²⁴

Finally, a microwave assisted synthesis of fluorinated propargylamines *via* A³ coupling of arylaldehydes, phenylacetylene and anilines with CuCl as catalyst has been described by the research group of Zhang. The reaction proceeds under solvent free conditions and the propargylamines were synthesized in 5-15 minutes in good yields.¹²⁵⁻¹²⁶

2.4.2 Copper(II) catalyzed alkylation of imines and A³ coupling reactions. In addition to the standard Cu(I)-catalyzed three components reactions, some authors have explored the use of Cu(II) catalysts to access propargylamine derivatives. The use of Cu(II) over Cu(I) catalysts may offer some advantages, mainly due to its higher stability to air oxidation and lower cost. In 2007, Yamamoto described the synthesis of propargylamino acid derivatives through the A³ coupling of alkynes, ethylglyoxalate and *N*-benzylallylamine in the presence of CuBr₂. The reaction proceeds in toluene at room temperature and led to propargylamine derivatives which were further transformed into polycyclic pyrrole-2-carboxylates *via* iridium-catalyzed cycloisomerization / Diels–Alder cycloaddition / dehydrogenation sequence under conventional and microwave heating conditions.¹²⁷

More recently, Larsen and co-workers deeply investigated the use of Cu(II) catalysts to access propargylamines. In an effort to find a suitable method to generate *N*-tosyl-propargylamines, Larsen envisaged that Cu(II) catalysts, such Cu(OTf)₂, could activate the Ts-imine **173** towards the addition of 1-octyne *via* copper acetylide intermediate. The Ts-imine substrates can also be generated *in situ* from appropriate aldehydes **176** and sulfonamides **177**. The scope of the reaction was then extended to aryl-aldehydes and to primary and secondary amines, leading to the synthesis of a variety of propargylamines **178** in high yields.¹²⁸ Larsen also reported an eco-friendly solvent-free KA² reaction of cyclohexanone **179** with primary and secondary amines catalyzed by CuCl₂ to access spiro-

propargylamines **180**.¹²⁹ The KA² coupling can be considered as a variant reaction analogous to the A³ coupling, in which a ketone is used in place of the aldehyde. In this work, several Cu(I) and Cu(II) catalysts were screened. The reaction proceeds through the formation of a ketimine intermediate followed by the attack of the copper acetylide formed *in situ* as shown in Scheme 37. However, despite being an efficient method for the synthesis of propargylamines, the KA² three-component couplings involving ketones, amines and alkynes have been poorly investigated because of the extremely low reactivity of the ketone substrates.¹³⁰

Scheme 37. Synthesis of propargylamines via Cu(II)-catalyzed A³ and KA² couplings

Larsen A³ coupling

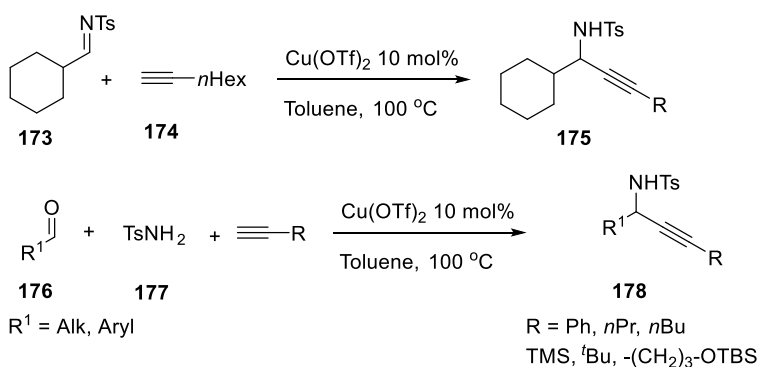

Larsen KA² coupling

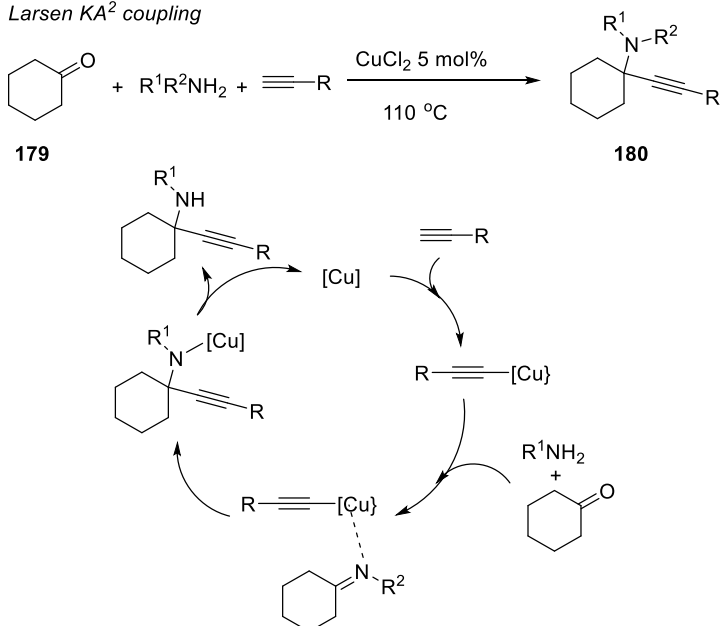

In fact, when the authors tried to replace the cyclohexanone **179** with 2-butanone, neither the ketimine intermediate nor the desired propargylamine product were observed under identical reaction conditions. Ketones are known to be less electrophilic than aldehydes and this explains the unsuccessful use of these substrates in the three-component coupling reactions. The use of higher temperatures, microwave conditions or standard drying agents did not improve the reaction. Thus, in order to overcome this synthetic challenge, Larsen and co-workers proposed the use of a Lewis acid additive to lower the energy barrier for the *in situ* ketimine formation and to activate the less reactive ketimines for subsequent acetylide attack. According to Ellman's work on the formation of aldimines using Lewis acid dehydrating agents,¹³¹ Ti(EtO)₄ was found as the best catalyst for the formation of ketimine intermediates. The propargylamines **181** were synthesized in high yields combining Ti(EtO)₄ and CuCl₂ in a KA² coupling reaction of ketones, amines and alkynes (Table 14).¹³² It is noteworthy that both cyclic amines and dialkyl amines can be used as substrates.

Table 14. Cu(II) and Ti(EtO)₄ co-catalyzed KA² coupling.

Entry	R ¹	R ²	R ³	R ⁴	R ⁵	Yield (%)
1	Et	Me		morpholine	<i>n</i> Hex	84
2	cyclopropyl	Me		piperidine	<i>n</i> Hex	71
3	<i>i</i> Pr	Me		morpholine	<i>n</i> Hex	75
4	Et	Me		piperidine	Ph	70
5	Et	Me		piperidine	(CH ₂) ₃ Cl	91
6	Et	Me		piperidine	^t Bu	90
7	Et	Me	H	CH ₂ -Naph	^t Bu	73
8	Et	Me	<i>n</i> Pr	CH ₂ -cyclopropyl	^t Bu	73

Ma and co-workers further investigated the KA^2 coupling of alkynes and secondary amines with aromatic ketones. In fact, when aromatic ketones were used as substrates, Larsen's approach using a combination of $CuCl_2$ and $Ti(EtO)_4$ failed. Thus, Ma developed a highly efficient method for the synthesis of propargylamine **185** using a combination of $CuBr_2$ and sodium ascorbate catalyst system able to favor the coupling of aromatic ketone **182**, pyrrolidine **183** and alkyne **184** (Scheme 38). Mechanistic studies were carried out with X-ray photoelectron spectroscopy (XPS) in order to understand the real catalytic species of this reaction. It was shown that $CuBr_2$ is reduced *in situ* to Cu(I) by sodium ascorbate and that Cu(I) is the real catalyst of the reaction. However, sodium ascorbate seems to act not only as a reducing reagent but also as a sort of co-catalyst, although the precise mechanism by which it operates remains unidentified.¹³³

Scheme 38. KA^2 coupling in the presence of Na-ascorbate.

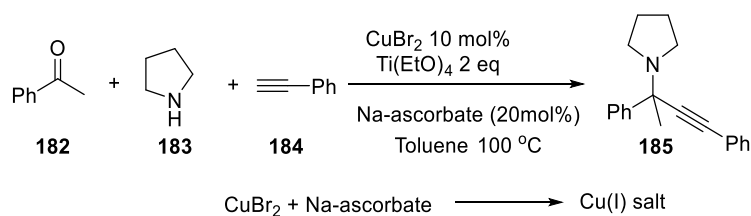

It is worth mentioning the work of Tajbaksh *et al.*, who described a three-component coupling reaction for the synthesis of propargylamines using of a Cu(II) salen complex as catalyst,¹³⁴ as well as the asymmetric Cu(II)-catalyzed approach recently developed by Su and co-workers.¹³⁵ Su reported a highly enantioselective synthesis of chiral propargylamines *via* the solvent-free three-component asymmetric coupling of aldehydes, alkynes and amines using $Cu(OTf)_2/Ph\text{-PyBOX}$ as a catalyst. Interestingly, the reaction was carried out under high-vibration ball-milling and the products were obtained in high yields and excellent ee when silica gel was used as a grinding auxiliary.

Finally, a microwave-accelerated preparation of propargylamines using CuPy₂Cl₂ as catalyst was reported later by Madhav *et al.*. Several aryl aldehydes were combined with phenylacetylene and secondary amines (morpholine, *N*-methylpiperazine, diethylamine, piperidine) under microwave irradiation and in the presence of CuPy₂Cl₂, affording propargylamines in good yields. The reaction is solvent-free and the catalyst CuPy₂Cl₂ is stable in air and water, soluble in water, immiscible in common organic solvents and recyclable.¹³⁶

2.4.3 Copper catalyzed alkynylation of alkylamines. An alternative approach to standard A³ coupling reactions in the synthesis of propargylamines has been proposed in 2004 by Li, who reported the CuBr-catalyzed alkynylation of sp³ C-H bond adjacent to a nitrogen atom.¹³⁷ When the tertiary aniline **186** was reacted with different alkynes at 100 °C in the presence of CuBr and *t*BuOOH, propargylamines **188** were obtained in 12–82% yield. A proposed mechanism for this reaction is reported in Scheme 39. The copper catalyst and *t*BuOOH catalyze the oxidation and formation of an iminium-type intermediate **189** (coordinated to copper) through activation of the sp³ C-H adjacent to the nitrogen. The transition metal catalyst activates the terminal alkyne, which is subsequently coupled with the imine leading to the desired propargylamines **188** and enables regeneration of the catalyst.

Scheme 39. Synthesis of propargylamines via CuBr-catalyzed alkylation of sp^3 C-H bond

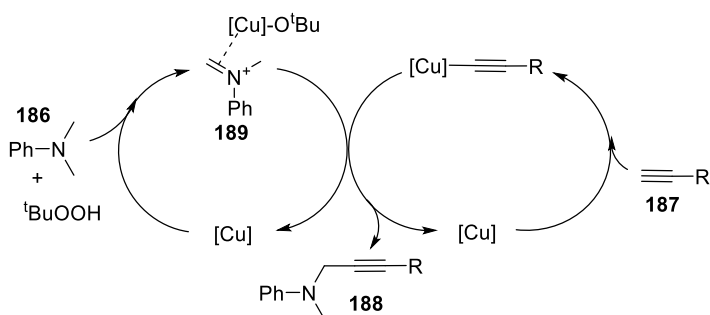
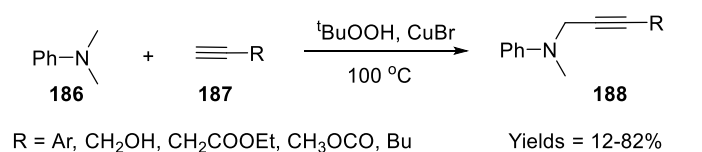

In 2008, Fu and co-workers proposed a similar approach to propargylamines **191** through the copper-catalyzed coupling of tertiary amines with terminal alkynes *via* NBS-mediated C-H activation. Amines **190** were reacted with different alkynes in the presence of a CuBr/NBS system, where the NBS acted as free radical initiator of the coupling reaction as shown in Scheme 40. It has been proposed that NBS firstly yields a succinimide and bromine free radical **192**, whilst the alkyne reacts with CuBr to form the Cu(I) acetylide **193**. Then, the tertiary aliphatic amine **190** reacts with the free radical species producing a new free radical **194**. The removal of a hydrogen radical gives the iminium ion intermediate **195**, which undergoes nucleophilic attack by the copper-activated acetylide complex **196** leading to the target product **191**. The scope of the reaction was investigated and several propargylamines **191** were obtained in good yields (Table 15).¹³⁸

Table 15. Copper catalyzed NBS-mediated C-H activation.

Entry	R ¹	R ²	R ³	Yield (%)

1	Ph	H	Ph	52
2	Ph	H	4-MeO-Ph	65
3	Ph	H	4-NO ₂ -Ph	40
4	Ph	H	4-Me-Ph	61
5	Ph	H	Naphtyl	53
6	CH ₃ -(CH ₂) ₁₀	H	4-Me-Ph	44
7	Ph	CH ₃	4-Me-Ph	43

Scheme 40. Alkynylation of tertiary amines with CuBr/NBS catalytic system.

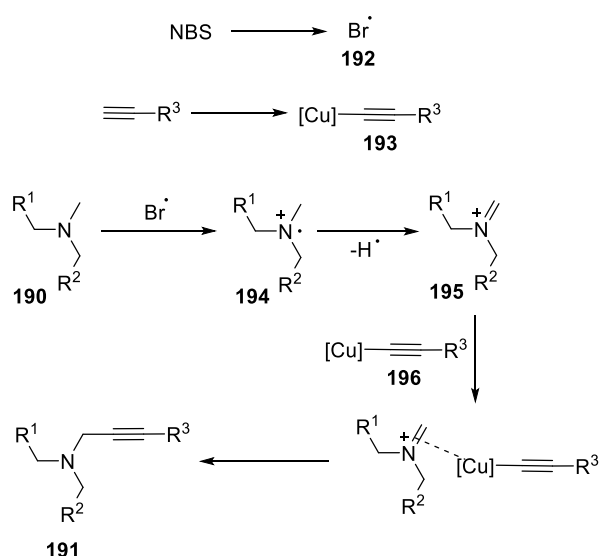

As evolution of the previous works, an original approach to propargylamines has been proposed in 2011 by Yu and Bao, who described the synthesis of **197** and **198** by exploiting the Cu(II)-catalyzed oxidative alkynylation reaction of trialkylamine *N*-oxides with alkynes in the absence of an external oxidant.¹³⁹ In this work, the terminal alkynes and the trialkylamine *N*-oxides were reacted in the presence of 10 mol% Cu(acac)₂ in DME at 110 °C affording several propargylamines **197** and **198** in excellent yields (>70%). The use of different Cu(I) catalysts was also explored by the authors. Interestingly, no product formation was recorded when CuI was used as catalyst whereas CuBr led to propargylamine products in

only 48% yield. A possible mechanism for the direct oxidative alkynylation of tertiary amine *N*-oxides is shown in Scheme 41.

Scheme 41. Cu(II)-catalyzed oxidative alkynylation reaction of trialkylamine *N*-oxides.

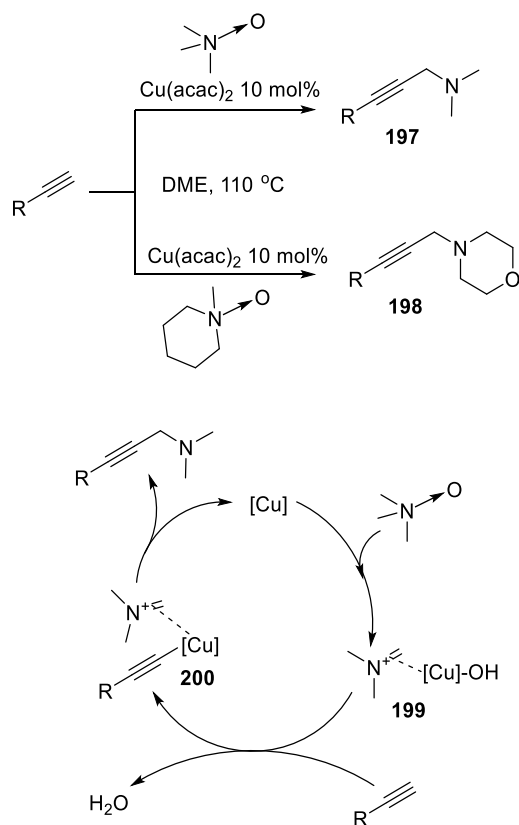

The reaction of the *N*-oxide with the Cu(II) catalyst produces the iminium ion intermediate **199** coordinated to copper hydroxide. This intermediate can then react with the terminal alkyne to generate the iminium ion intermediate **200** coordinated to the copper acetylide. Subsequent nucleophilic attack of the copper acetylide on the iminium ion yields the desired products **197** and regenerates the Cu(II) catalyst. The reactions of the less acidic aliphatic alkynes also proceeded efficiently to give the corresponding products in satisfactory yields, probably due to the strong basicity of the [Cu]-OH adduct generated *in situ*.

2.4.4 Copper catalyzed propargylic amination of propargyl esters. In 1994, Murahashi and co-workers found that propargylamines could be obtained *via* the copper-catalyzed propargylic amination of propargylic esters with various amines. The methodology proved to

be very efficient and led to the synthesis of both α -tertiary and α -secondary propargylamines **202** in good yields using 5 mol% of CuCl as catalyst. Both propargyl acetates and propargylphosphates proved to be good substrates, and both primary and secondary amines can be used (Table 16).¹⁴⁰

Table 16. Cu(I)-catalyzed propargylic amination of propargyl esters.

X = Ac, OP(O)(OEt)₂

Entry	X	R	R ¹	R ²	R ³	Yield (%)
1	OP(O)(OEt) ₂	Me	H	H	Ph	85
2	OP(O)(OEt) ₂	Me	H	Bn	Allyl	60
3	OP(O)(OEt) ₂	Ph	H	Pyrrolidine		75
4	OP(O)(OEt) ₂	Me	H	OH	Bn	95
5	Ac	C ₅ H ₁₁	H	2-Me-piperidine		72
6	Ac	Me	Me	H	Bn	62

The reaction proceeds as shown in Scheme 42. The catalyst CuCl reacts with the terminal alkyne **201** to afford the Cu-acetylide **203**. Elimination of the ester group leads to the formation of the zwitterion **204** and/or the carbene **205**. These latter react with the amine to afford the desired propargylamine **202**.

Scheme 42. Mechanism of reaction for the propargylic amination of propargyl esters.

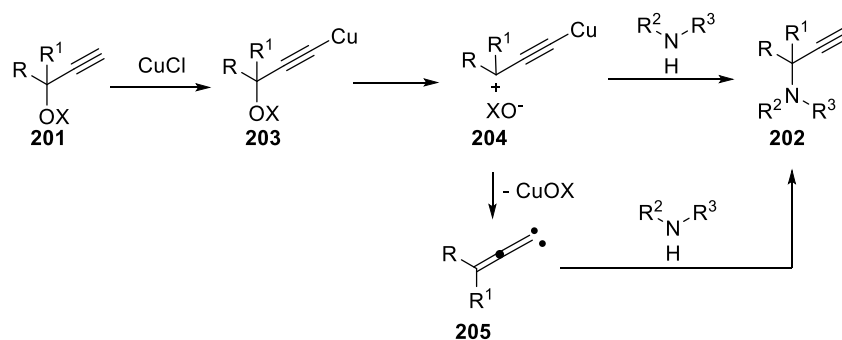

Starting from this seminal work, in 2008, van Maarseveen and co-workers¹⁴¹ and Nishibayashi and co-workers¹⁴² independently reported the first copper-catalyzed asymmetric propargylic amination of propargylic acetates with primary amines and secondary amines, respectively. A series of copper–pyridine-2,6-bisoxazoline (PyBOX) complexes was investigated by van Maarseveen, who eventually found that ligand **207** and CuI comprised the best catalyst complex. On the other hand, Nishibayashi used CuOTf(C₆H₆)_{0.5} and the chiral ligand (*R*)-Cl-MeO-BIPHEP **209** to obtain propargylamines **210** with high ee, as determined by HPLC analysis (Scheme 43). The absolute configuration of **210** was established by analogy converting the appropriate propargylamine into the corresponding *N*-methyl-*N*-(1-phenylpropyl)aniline.

Scheme 43. Copper-catalyzed asymmetric propargylic amination of propargylic acetates.

van Maarseveen

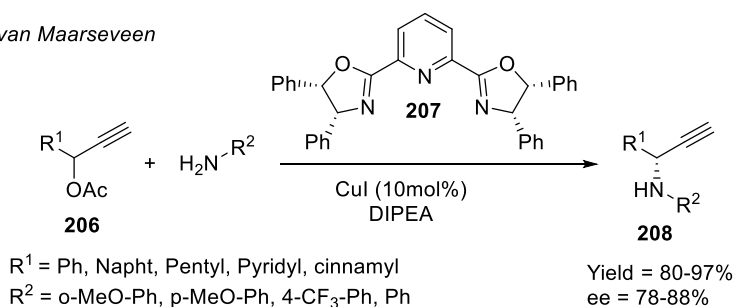

Nishibayashi

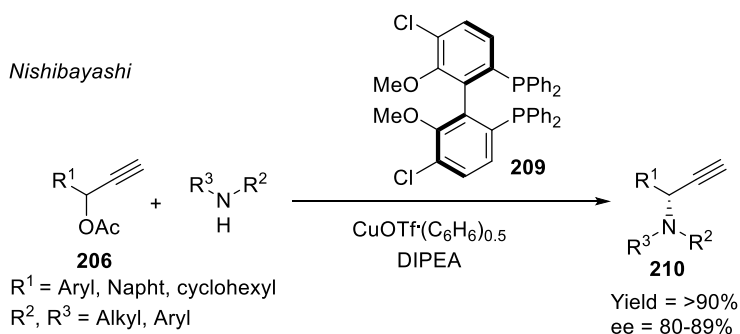

For both reactions the mechanism can be described as reported in Scheme 44.¹⁴³ In the first step, the copper complex probably forms a π complex with the alkyne. Deprotonation with a base gives the copper acetylide **211**. It is important to note that the reaction does not work with internal alkynes since no proton extraction and consequent formation of the copper acetylide is possible. The intermediate **211** loses the acetate group through an $\text{S}_{\text{N}}1$ -type mechanism and the resulting electrophilic intermediate **212** is stabilized by resonance involving the Cu complex. Finally, the copper complex **212** is attacked by the amine nucleophile and, after proteolysis, the propargylamine **208** is released to complete the catalytic cycle. The regio- and enantioselectivity of the reaction is most probably determined during the attack of the amine on the copper-ligand complex **212**. Nishibayashi and co-workers later confirmed, using density functional theory (DFT) calculation on the model reaction, that a copper-allenylidene complex **213** is formed and the attack of amines to the γ -carbon atom of the allenylidene is the key step of the reaction. To explain the

enantioselectivity of the reaction a transition state consisting of copper-allenylidene complex bearing a chiral ligand BIPHEP has been proposed as shown in Scheme 44. The amine/aniline attacks the copper-allenylidene complex from the *Re* face, where edge-to-face aromatic interaction between the two phenyl groups is considered to play an important role in achieving the high enantioselectivity. It is interesting to note that the CH moiety at the ortho-position in the benzene ring of propargylic acetate is necessary to achieve the high enantioselectivity. In fact, when the catalytic amination of propargylic acetate bearing a 2,6-dimethylphenyl moiety was carried out, no enantioselectivity was observed due to the lack of a CH moiety able to coordinate the benzene ring.

Scheme 44. Mechanism of the asymmetric propargylic amination reaction of propargylic acetates.

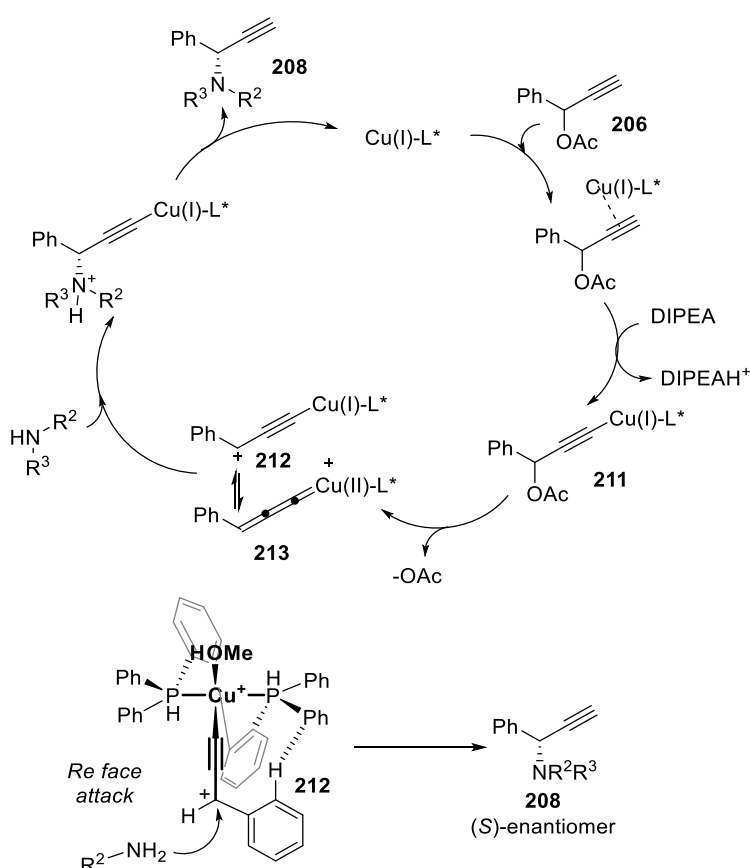

This methodology was later used by van Maarseveen and co-workers for the total synthesis of (+)-Anisomycin and (-)-Cytoxazone.¹⁴⁴ Similar approaches, using different chiral ligands,

have then been used by other research groups (Table 17). Nishibayashi and co-workers reported the synthesis of enantioenriched propargylamines using (*R*)-BINAP as chiral ligand and CuOTf₁/2C₆H₆ (*entry 1*).¹⁴⁵ Hu and co-workers used the chiral tridentate P,N,N ligand **216** together with CuCl (*entry 2*).¹⁴⁶ Finally, Mino and co-workers described the copper-catalyzed asymmetric propargylic amination of propargylic acetates with amines using BICMAP as chiral ligand (*entry 3*).¹⁴⁷ The models for the enantioinduction of different ligands are reported in Table 17, and are based on the model of the transition state (TS) proposed earlier by Nishibayashi.¹⁴³

Table 17. Chiral ligands for the asymmetric propargylic amination reaction.

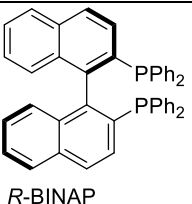
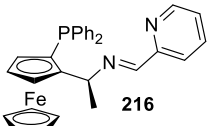
Entry	Ligand	Copper	ee (%)
1	 <i>R</i> -BINAP	CuOTf ₁ /2C ₆ H ₆	up to 99
2	 216	CuCl	up to 97

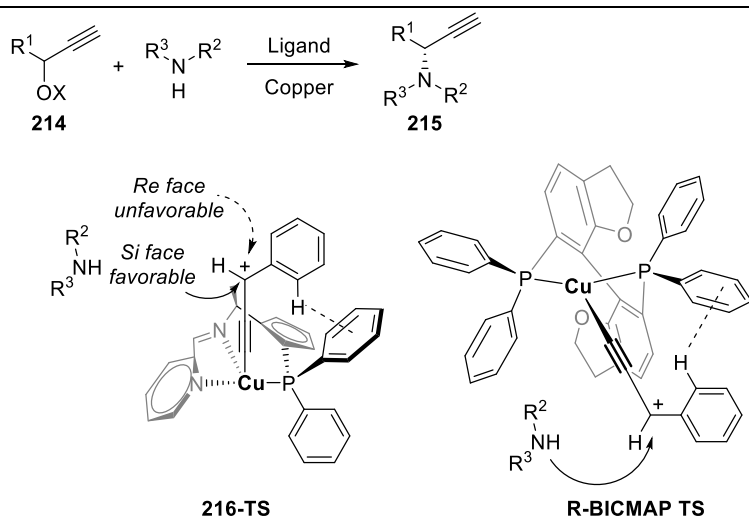

3

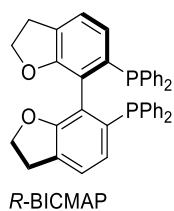
CuOTf/2C₆H₆

up to 90

An interesting approach using carbamates as substrates has been recently developed by Hu and co-workers.¹⁴⁸ The authors described the asymmetric synthesis of propargylamines **219** *via* the decarboxylative propargylic amination of propargyl carbamates **217** using a Cu-tridentate ketamine P,N,N-complex **218** as shown in Scheme 45. The copper-ligand catalyst is supposed to react with the alkyne and form a copper-allenylidene complex **221**, as described by Nishibayashi. The subsequent elimination of the carbamic acid **220** and the following decarboxylation allows the free amine to react with the allenylidene, forming the desired propargylamine **219**. The reaction is performed under mild conditions and affords a large variety of substituted propargylamines.

Scheme 45. Decarboxylative propargylic amination of propargyl carbamates.

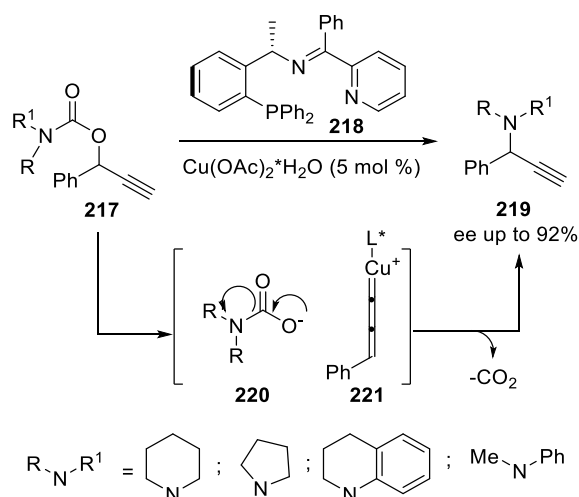

Finally, a closely related approach to tertiary propargylamines **224** exploiting the formation of a copper-allenylidene complex intermediate was also developed by Nishibayashi and co-

workers in 2009. The opening of the epoxide **222** with different amines in the presence of $\text{Cu}(\text{OTf})_2$ and (*R*)-DTBM-MeO-BIPHEP **223** ligand was described. A variety of propargylamines **224** with ee up to 94% were synthesized.¹⁴⁹ Theoretical studies indicate that a copper-allenylidene complex like **225** may be formed as a key intermediate which drives the enantioselectivity of the amination reaction (Scheme 46).

Scheme 46. Synthesis of tertiary propargylamines 224 from epoxide 222.

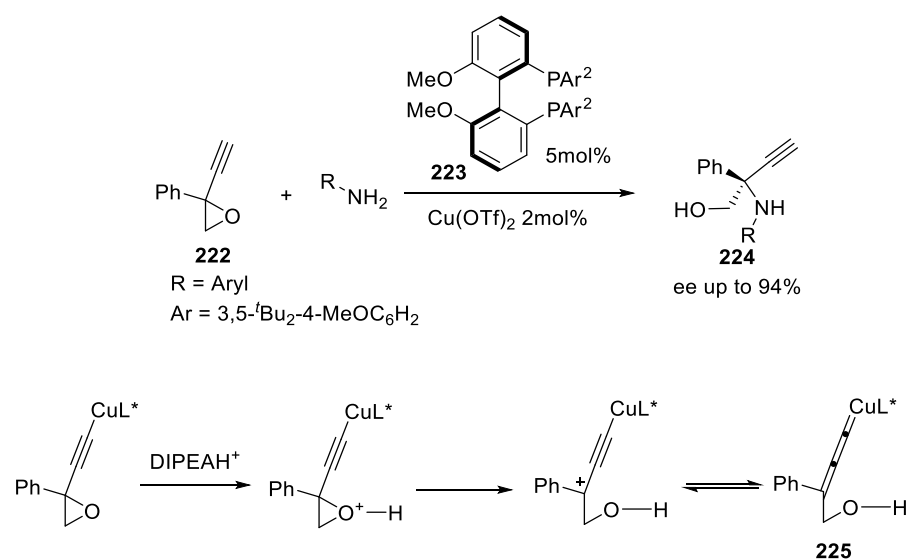

2.4.5 Copper catalyzed hydroamination reactions. The hydroamination reaction is the direct addition of nitrogen and hydrogen on carbon-carbon multiple bonds. Despite hydroamination reactions pose a significant synthetic challenge due to the repulsion between the nitrogen lone pair and the alkyne π system as well as in the control of the regioselectivity, some methods to obtain propargylamines have been developed. In 2008, Jiang and Li firstly reported the synthesis of propargylamino acids *via* a copper-catalyzed amine-alkyne-alkyne addition reaction. Diallylamine, phenylacetylene and ethyl propiolate were reacted in toluene at 100 °C in the presence of CuBr_2 , affording propargylamino derivatives **226** in good yields (Scheme 47).¹⁵⁰ Different copper catalysts were screened. The reaction afforded the desired products **226** in high yields also when CuBr was used as a catalyst. However, the cheaper CuBr_2 was preferred for the development of the methodology. A plausible mechanism for the

three component reaction is shown in Scheme 47. First, a copper-catalyzed hydroamination of the electron-deficient propiolate by a secondary amine occurs, leading to the formation of the intermediate **227**. Subsequent reaction of **227** with an alkyne results in intermediate **228**, which tautomerizes into the iminium intermediate **229**. Finally, the intramolecular transfer of the alkyne moiety to the iminium ion produces the propargylamino acid derivative **226** and regenerates the copper catalyst. As Cu(I) and Cu(II) generated similar results, the active catalyst is most likely to be Cu(I) as Cu(II) can be converted into Cu(I) readily by reacting with the enolate, the terminal alkyne, or the amine.

Scheme 47. Copper catalyzed amine-alkyne-alkyne addition reaction.

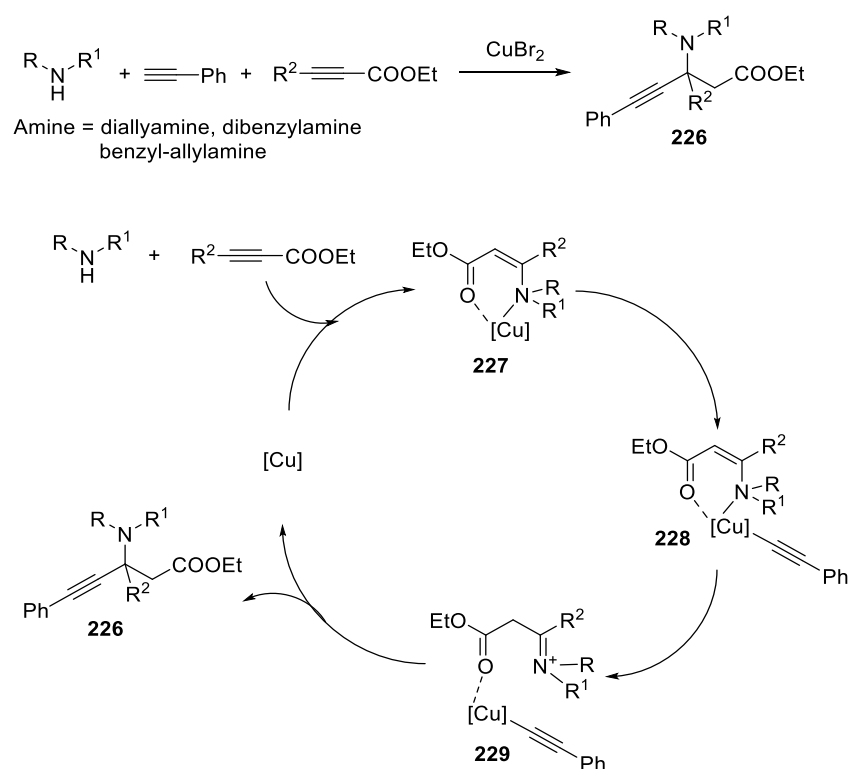

Later, the same authors described a tandem anti-Markovnikov hydroamination and alkyne addition reaction catalyzed by both Cu(I) or Cu(II) catalysts (Scheme 48). Au or Ag catalysts were also screened but proved to be inefficient and no propargylamine products were obtained. Various propargylamines **230** were obtained in moderate to good yields when CuBr was used as catalyst.¹⁵¹ According to Scheme 48, the reaction proceeds first through the

hydroamination of the alkyne followed by the addition of the alkyne (or copper acetylide) on the formed enamine/iminium intermediate. The terminal alkyne is activated by CuBr and reacts with a secondary amine to give the hydroamination product **231**. This latter tautomerizes into iminium **232**. Subsequently, an intramolecular transfer of the alkyne moiety to the iminium ion **232** produces propargylamine **230** and regenerates the copper catalyst.

Scheme 48. Tandem anti-Markovnikov hydroamination and alkyne addition reaction.

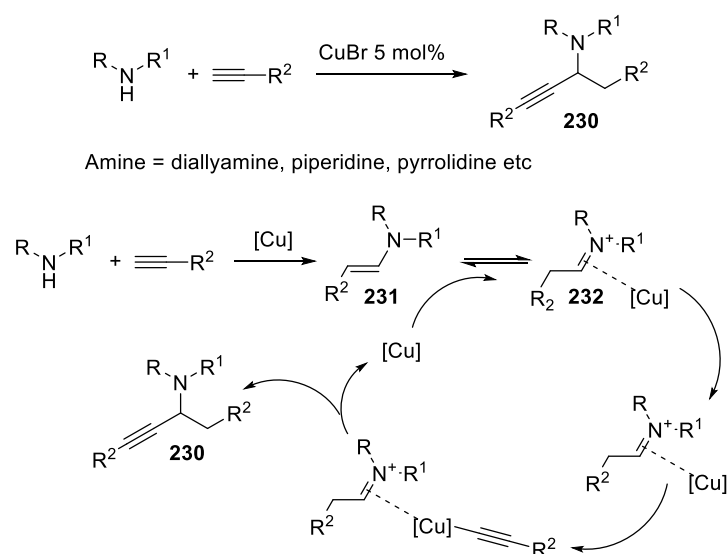

2.4.6 Copper catalyzed retro-Mannich and deselenative C-H insertion reactions.

An interesting approach to propargylamines *via* a retro-Mannich synthesis has been described by Zhu *et al.*. The authors developed a copper-catalyzed coupling of phenylacetylenes with Mannich bases generated *in situ* through a chlorine(1+) ion-initiated retro-Mannich-type fragmentation. Treatment of the Mannich base **233** with phenylacetylene in the presence of CuCl₂, *N*-chloro succinimide (NCS) and NaHCO₃ affords the propargylamine **234** in 82% yield (Scheme 49). Different Mannich bases were investigated and compound **233** was found to afford propargylamines with better yields. Several oxidants were also screened (NCS, NBS, I₂, *t*BuOOH, PhI(OAc)₂) and the best conversion was obtained when NCS was used in the presence of NaHCO₃. According to the proposed mechanism, the Mannich base **233** is

firstly chlorinated by NCS affording **235**, which by fragmentation is converted into the product **236** and iminium ion **237**. The phenylacetylene reacts with $\text{CuCl}_2 \cdot \text{H}_2\text{O}$ yielding the copper acetylide intermediate *via* C-H activation, which then reacts with the *in situ* formed **237** leading to propargylamine **234**.¹⁵²

Scheme 49. Retro-Mannich approach to propargylamines.

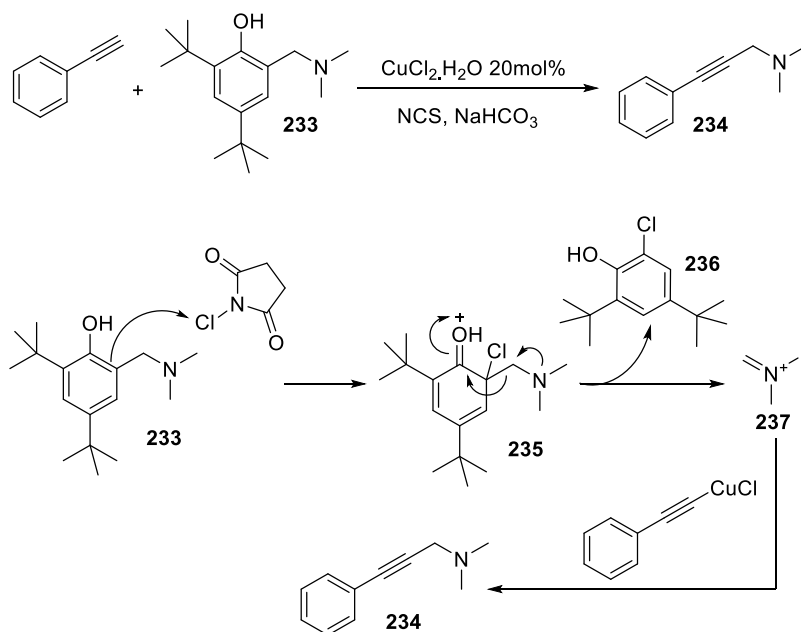

In 2009, Ogawa and Mitamura reported an alternative and interesting approach to propargylamines based on the $\text{Cu}(0)$ -induced deselenative insertion of selenoamides into acetylenic C-H bond. Selenoamides are a class of unusual compounds in organic synthesis but they are relatively stable and retain unique reactivity. The authors found that selenoamides show carbenoid-like reactivity when treated with $\text{Cu}(0)$ powder.¹⁵³ Starting from this discovery, a deselenative C-H insertion reaction leading to propargylamines was developed. A series of propargylamines **239** was synthesized efficiently in high yields from a range of selenoamides **238** (Table 18).¹⁵⁴ The reaction proceeds at 110°C without any solvent and in the presence of an excess of $\text{Cu}(0)$ powder. The precise mechanism of the reaction has

not been fully elucidated. However, experiments carried out with deuterated alkynes confirm that a C-H(D) insertion reaction occurs.

Table 18. Synthesis of propargylamines *via* deselenative C-H insertion.

Entry	R ²	Yield (%)
1	Ph	99
2	4-MeO-Ph	99
3	4-Pent-Ph	99
4	4-Cl-Ph	84
5	CH ₂ OMe	44
6	CH ₂ N(Me) ₂	59

2.4.7. Heterogeneous catalysis: solid-supported copper catalysts and copper nanoparticles. A large number of examples of propargylamine syntheses *via* A³ coupling reactions using heterogeneous catalysts have been reported in the literature and more methods will likely be developed in the future. The main advantage in using supported catalysts or nanoparticles arises from the possibility to recycle the catalysts and to re-use them several times, thus making the approach cheaper and more environmentally friendly.

A silica-gel anchored CuCl heterogeneous catalyst was developed in 2007 by Sreedhar *et al.* and used for the synthesis of propargylamines *via* a standard copper-catalyzed A³ coupling of an amine, aldehyde and alkyne. The catalyst was recovered almost quantitatively by simple filtration and reused several times.¹⁵⁵

Fodor *et al.* later developed an interesting method to synthesize propargylamine derivatives using a heterogeneous 4Å molecular sieve-supported Cu(II) catalyst. This catalyst was used successfully in the A³ coupling under solvent-free conditions or in refluxing toluene to afford a great number of propargylamines in high yields. The catalyst was easily prepared by mixing 4Å molecular sieves and CuCl₂·2H₂O in deionized water and can be easily recovered and reused several times without loss of its catalytic activity.¹⁵⁶ More recently, Mandapati and co-workers developed the polymer-anchored Cu(II) complex **240** that was employed as efficient and reusable catalyst for the synthesis of propargylamines *via* A³ coupling reactions (Scheme 50).¹⁵⁷

Scheme 50. Polymer anchored copper complex 240 and Cu(I)-N₂S₂-salen type complex 241.

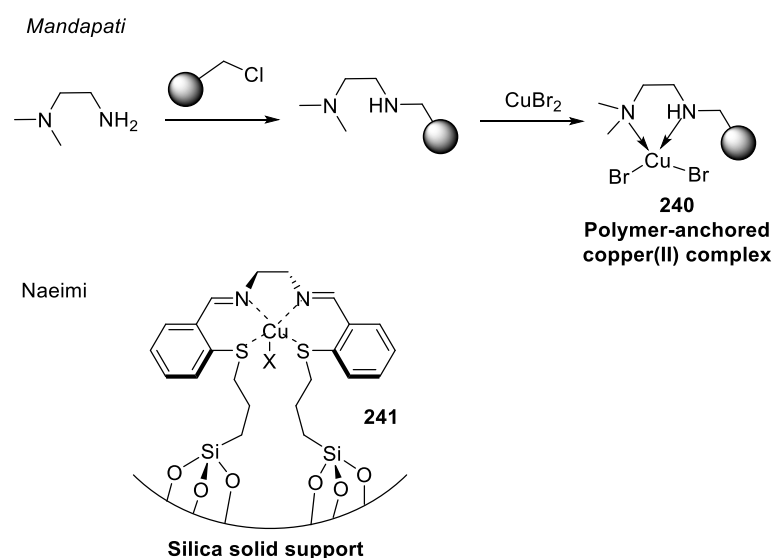

A Cu(I)-N₂S₂-salen type complex **241** covalently anchored onto MCM-41 silica was developed by Naeimi *et al.* and used in A³ couplings to synthesize a set of propargylamines (Scheme 50).¹⁵⁸

Luz *et al.* described the use of a Cu-MOFs solid catalyst for the three-component synthesis of propargylamines **242** (Scheme 51).¹⁵⁹ MOFs (Metal–Organic Frameworks) are a type of coordination polymers where metal nodes are connected by organic linkers through strong

coordination bonds in a tridimensional net, forming crystalline, hybrid microporous materials. In this work, different Cu-MOFs were screened and Cu(2-pymo)₂ proved to be able to catalyze an A³ coupling to obtain propargylamines in good yields and with a reasonable scope. Their activity proved to be similar to that reported when other solid catalysts and homogeneous Cu catalysts were used. A similar protocol is also described by Li *et al.*¹⁶⁰

Phan and co-workers recently described the use of a Cu-MOF catalyst (MOF-199) for the synthesis of propargylamines **243** *via* the direct oxidative C-C coupling reaction between *N,N*-dimethylanilines and terminal alkynes.¹⁶¹ Later, the same authors reported the synthesis of propargylamines **243** *via* sequential methylation and C-H functionalization of *N*-methylanilines and terminal alkynes under MOF Cu₂(BDC)₂(DABCO) catalysis. The *tert*-butyl hydroperoxide was used in the reaction as the methylating reagent (Scheme 51).¹⁶²

Scheme 51. Synthesis of propargylamines with heterogeneous catalysts.

Luz *et al.*

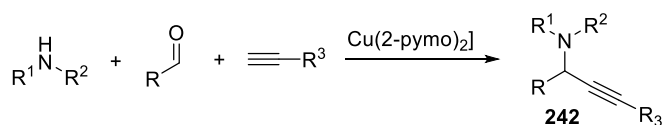

Phan and co-workers

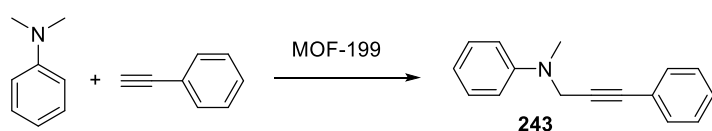

Phan and co-workers

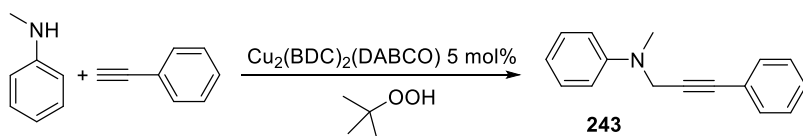

Graphene oxide-supported CuCl₂ has recently been used as an efficient, green and practical catalyst to synthesize propargylamines *via* a multicomponent A³ coupling reaction. The propargylamines have been readily obtained in good to excellent yields (85–96%) and under

MW irradiation. The catalyst is easily recoverable through filtration and can be recycled at least five with no decrease in yield.¹⁶³

Finally, Bosica and Gabarretta described an Amberlyst A-21 supported CuI heterogeneous catalyst for the A³ coupling under solvent-free conditions. The catalyst was easily prepared, recovered and reused for several times, without any appreciable loss in its activity.¹⁶⁴

Copper nanoparticles have been developed and largely used by several research groups as catalysts in the synthesis of propargylamines. Kantman and co-workers reported the synthesis of both aliphatic and aromatic propargylamines *via* A³ coupling using nanocrystalline CuO as recyclable catalyst.¹⁶⁵ In addition, copper ferrite (CuFe₂O₄) nanoparticles have been used by Kantam *et al.* to catalyze the three-component coupling of aldehydes, amines and alkynes to afford propargylamines.¹⁶⁶ Other authors reported the synthesis of propargylamines *via* A³ coupling reactions catalyzed by Cu-MCM-41 nanoparticles,¹⁶⁷ Cu-Ni bimetallic catalysts,¹⁶⁸ CuO nanoparticles supported on graphene oxide (Fe₃O₄ NPs/GO–CuO NPs),¹⁶⁹ copper oxide nanoparticles (CuO NPs) prepared according to a simple and effective protocol that involves the use of the *Anthemis nobilis* flowers extract as both reducing and stabilizing agent,¹⁷⁰ and, finally, by lanthanum loaded CuO nanoparticles prepared from CuO and La(NO₃)₃.¹⁷¹

Further examples of propargylamine synthesis using heterogeneous copper catalysis include the use of Cu@SiO₂ nanocatalyst formed by supporting Cu nanoparticles onto a silica aerogel,¹⁷² coppersilicate catalyst (CuSBA-15),¹⁷³ nanoporous CuO,¹⁷⁴ superparamagnetic CuFe₂O₄ nanoparticles,¹⁷⁵ and nano magnetite functionalized 2,20-biimidazole complexes of Cu(I).¹⁷⁶

2.5 Zinc catalyzed synthesis of propargylamines

Zinc is known for its ability to activate alkynes and form zinc acetylides, which can be exploited in the synthesis of propargylamines. The first synthesis of propargylamine

derivatives using zinc catalysts has been reported in 1999 by Carreira and co-workers who described the synthesis of a series of *N*-hydroxy-propargylamine derivatives **246** in good to excellent yields. Different alkynes were treated with Zn(OTf)₂ in the presence of DIPEA and reacted with aromatic and aliphatic nitrones **245**. Higher yields were observed when aliphatic nitrones were used.¹⁷⁷ The proposed mechanism of the reaction is illustrated in Scheme 52. The zinc forms a complex with the terminal alkyne **244** which is in turn deprotonated by DIPEA affording the zinc alkynylide **247**. The latter reacts with the nitron **245** to form the intermediate **248** which is converted into the final product **246** by action of DIPEA-OTf leading finally to the regeneration of the Zn(OTf)₂ catalyst.

Scheme 52. Zinc-catalyzed synthesis of *N*-hydroxy-propargylamines **246**

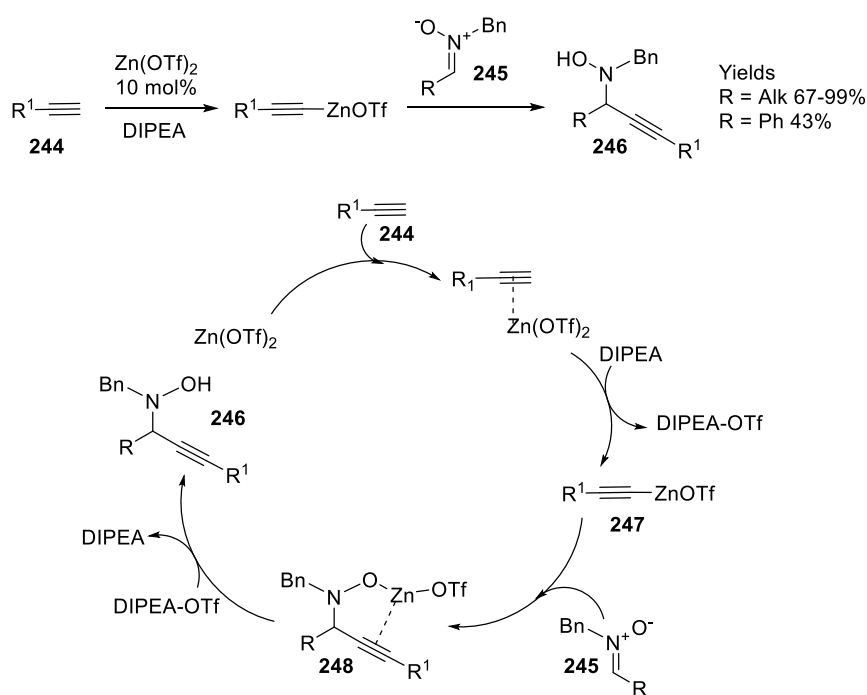

Later, a chiral version of the same reaction was described by the same authors using enantiopure nitron derivatives as substrates.¹⁷⁸ An extension of this work where ZnCl₂ was used as catalyst in place of Zn(OTf)₂ was also reported.¹⁷⁹ Recently, Downey demonstrated that the reaction of zinc acetylides, catalytically generated with ZnBr₂, with *N*-phenyl nitrones can be accelerated by the addition of TMSOTf.¹⁸⁰

In 2002, Vallee and co-workers described the synthesis of *N*-hydroxy-propargylamines **249** *via* the addition of terminal alkynes to aryl and alkyl nitrones in the presence of Et₂Zn.¹⁸¹ The reaction proceeds under mild conditions (toluene, 20 °C) and without the presence of any base. In order to elucidate the mechanism of the reaction, the authors carried out different experiments using Me₂Zn as a catalyst. In an initiation step, a MeZn complex **252** is generated by the reaction of alkynyl-methylzinc **250** with a nitron. Alternatively, the complex **253** can be formed by the reaction of Me₂Zn with the nitron first and the alkyne later. In the end, the complex **253** would be converted into **252**. This latter can dimerize affording **254** by reaction with free hydroxylamine **256** and then the reaction can proceed through the cycle as reported in the Scheme 53.

Scheme 53. Synthesis of *N*-hydroxy-propargylamines 249.

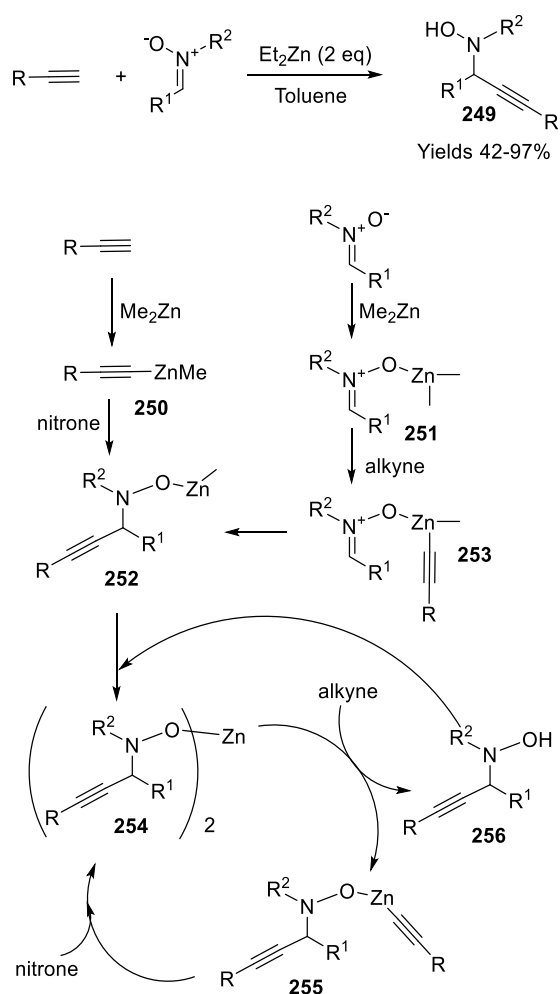

Following the initial work of Carreira on nitrones, other zinc-mediated addition reactions of alkynes to imines were then investigated (Scheme 54). Imines are known to be poor electrophiles and poorly reactive towards metal acetylides. To overcome this, Jiang and Si used TMSCl to activate the imine **257** towards the addition of zinc-acetylides. Thus, a series of terminal alkynes were added to imines **257** in the presence of catalytic ZnCl₂, Et₃N and TMSCl leading to propargylamines **258** in good yields. Also, chiral substrates were used leading to corresponding propargylamines with good dr.¹⁸²

A similar strategy to perform the addition of alkynylzinc reagents to imines was reported by Carreira and coworkers. *N*-Aryl and *N*-alkylimines **260** were treated with an acyl chloride leading to the formation of the acyl-iminium intermediate **261**. The latter is more electrophilic than the parent imine and it then undergoes addition with zinc-acetylide **259** to afford the propargylamides **262** in good yields.¹⁸³ It is noteworthy that diphenylphosphinoyl chloride can be used in place of acyl chlorides to generate the iminium ion intermediates.

Scheme 54. Zinc-catalyzed addition of alkynes to imines.

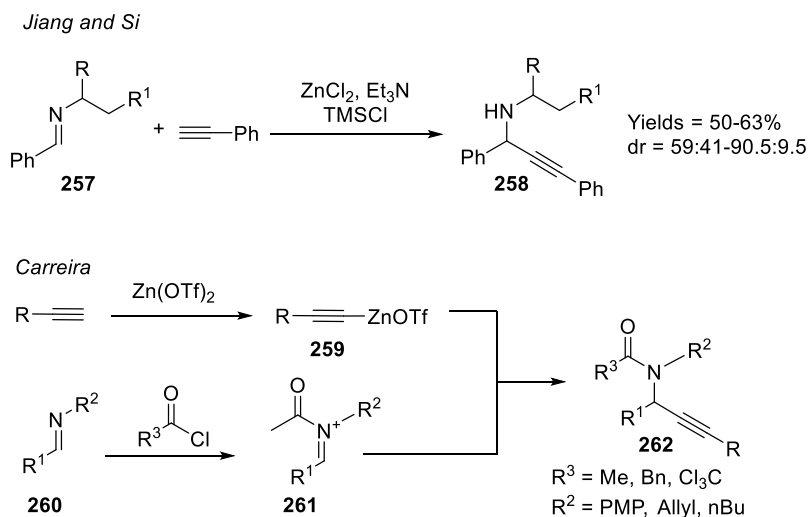

As further extension of these works, Kim and co-workers reported the addition of zinc alkynylides to *N*-activated imines, namely imines bearing an electron-withdrawing group such as a tosyl or a mesyl. The zinc alkynylide was generated *in situ* through the reaction of

terminal alkynes with ZnBr_2 in the presence of DIPEA (Scheme 55). The propargylamines **263** were generally obtained in high yields, superior to those reported by Carreira.¹⁸⁴⁻¹⁸⁵

Later, Bolm and co-workers reported a similar approach to propargylamines **264** using a stoichiometric amount of Me_2Zn . In addition, the authors also described the one pot synthesis of propargylamines **265** through a formal A^3 coupling where different aldehydes were reacted with *o*-methoxyaniline and alkynes in an excess of Me_2Zn . The resulting zinc alkynylide is then formed and it undergoes nucleophilic addition on the *in situ* formed *o*-methoxy-imine, leading to the desired propargylamine in good-excellent yields (Scheme 55).¹⁸⁶

Scheme 55. Zinc-mediated addition of alkynes to *N*-activated imines.

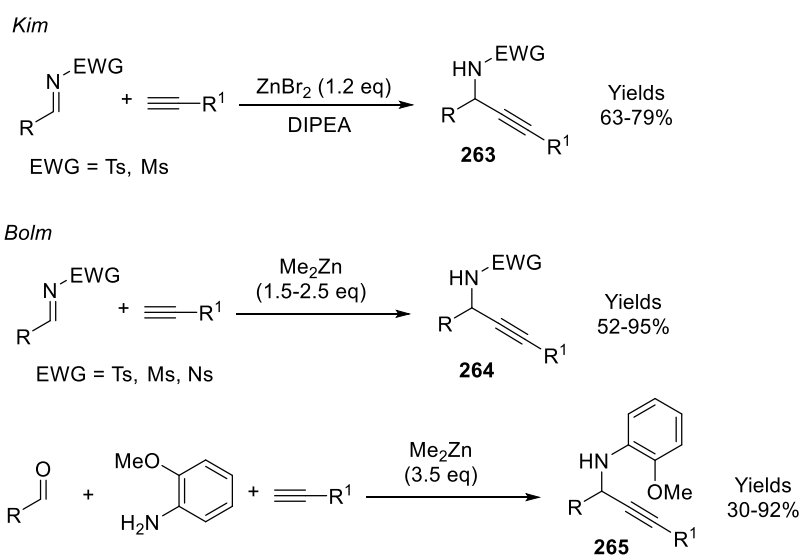

Ramu *et al.* reported the synthesis of a series of propargylamines *via* a multicomponent coupling of aldehydes, alkynes and cyclic secondary amines using $\text{Zn}(\text{OAc})_2 \cdot \text{H}_2\text{O}$ as catalyst. The reactions were carried out in the presence of air, and led to the desired amines in excellent yields.¹⁸⁷ Similarly, Kantam and co-workers described the one-pot synthesis of propargylamines *via* the A^3 coupling of aldehydes, amines and alkynes catalyzed by zinc dust. It has been assumed that $\text{Zn}(0)$ could form a zinc acetylide intermediate by the C–H bond activation of the alkyne.¹⁸⁸

Zinc catalyzed asymmetric syntheses of propargylamines have been also reported in the literature. Wei *et al.* reported a zinc-mediated asymmetric synthesis of *N*-hydroxy-propargylamines through the reaction of alkynylzinc reagents, prepared *in situ* from terminal alkynes and Me₂Zn, with nitrones using di-(*tert*-butyl)zinc tartrate as a chiral auxiliary. Propargyl *N*-hydroxylamines were obtained with up to 95% ee.¹⁸⁹

More recently, Zhang and co-workers described the enantioselective synthesis of optically pure quaternary propargylamines **267**, **269**, and **270** through a highly enantioselective zinc/BINOL-catalyzed alkylation of ketimines (Scheme 56). Several propargylamines were obtained in excellent yields and high ee. Both the electronic and steric effects of substituents at the 3,3'-positions of the BINOL-type ligands **271-273** proved to be critical for the enantioselectivity of the reaction. The BINOL **271**, bearing a Tf at the 3,3' positions, proved to be the best ligand for the zinc when ketimines **266** were reacted with different alkynes. On the other hand, the same ligand proved to be less efficient when **268** was treated with phenylacetylene. In this case, the BINOL **272** proved to be the best ligand, leading to propargylamine **269** with 94% ee. Notably, both enantiomers **269** and **270** can be enantioselectively obtained by tuning the electronic properties of the BINOL-type ligand or the reaction temperature. In fact, when **268** and phenylacetylene were reacted with Zn(Me)₂ in the presence of ligand **272** at room temperature, the propargylamine **269** was obtained, whilst, when the same reaction was carried out at 0-5 °C, the opposite enantiomer **270** was recovered with 44% ee. Similarly, when **268** was reacted at room temperature with phenylacetylene and in the presence of the ligand **273** the enantiomer **270** was obtained with 83% ee.¹⁹⁰ The absolute configuration of propargylamines was determined by X ray analysis of crystallized samples.

Scheme 56. Zinc/BINOL-catalyzed alkyne addition to ketimines.

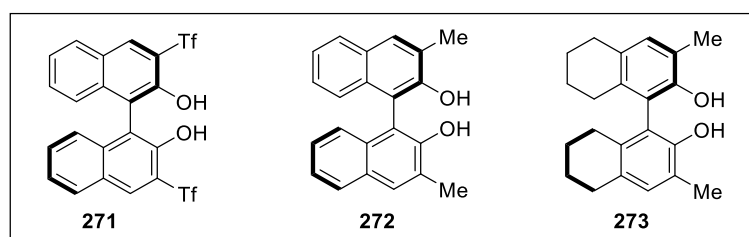
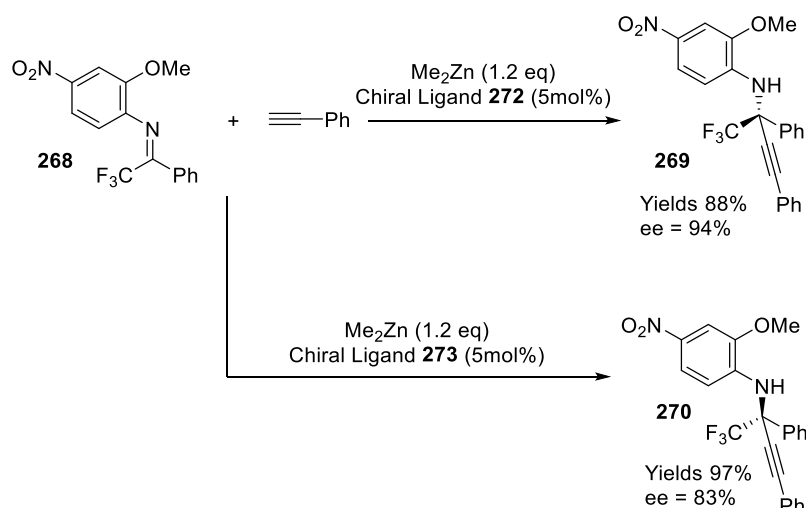
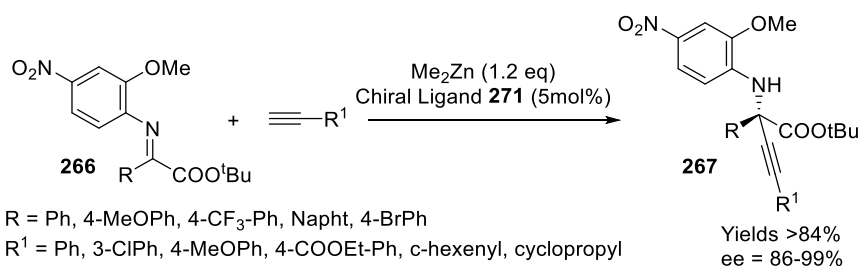

Recently, Periasamy described the synthesis of a series of propargyl-piperazine derivatives *via* a ZnCl_2 catalyzed addition of alkynes to iminium intermediates. A set of chiral piperazine derivatives **275-277** were reacted with appropriate alkynes and aldehydes in the presence of ZnCl_2 in toluene at 100 °C, affording the corresponding propargylamines **274** in high yields and with excellent dr (>98:2). Similar to the mechanism proposed by Carreira, the ZnCl_2 is supposed to form a complex with the alkyne at first. The piperazine substrate then deprotonates the alkyne leading to the formation of an alkynylzinc intermediate which in turn reacts with the *in situ* formed piperzinylium to afford the propargylamines **274**.¹⁹¹ (Scheme 57).

Scheme 57. ZnCl₂ catalyzed synthesis of propargyl-piperazine derivatives.

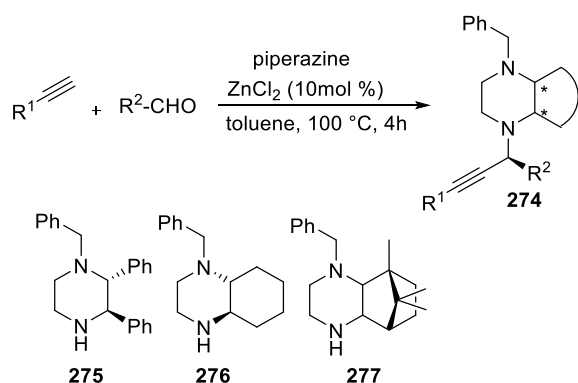

Finally, it is noteworthy to mention an original approach developed by Nakamura where propargylamines **279** were synthesized *via* a zinc-catalyzed redox cross-dehydrogenative coupling of other propargylamines **278** and terminal alkynes (Scheme 58). In this reaction, a C(sp)-C(sp³) bond is formed between the carbon adjacent to the nitrogen atom in the propargylamine and the terminal carbon of the alkyne with reduction of the C-C triple bond of the starting propargylamine, which acts as an internal oxidant. The authors suggest that a zinc alkynylide species is generated from the terminal alkyne. Next, the multiple bond of propargylamine substrate **278** would be coordinated by Zn(II) to give a zinc-complex which, in turn, would afford an iminium intermediate *via* a 1,5-hydride shift. Finally, the attack of the zinc alkynylide to the iminium ion furnishes the 1,6-enyne **279**. The reaction is interesting as it allows the alkylation of alkyne **278** at the carbon adjacent to the nitrogen atom to generate an allyl group.¹⁹²

Scheme 58. Zn(II)-catalyzed redox cross-dehydrogenative coupling of propargylamines and terminal alkynes.

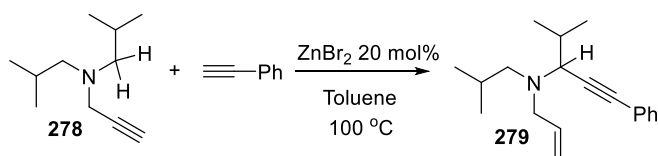

2.6 Gold catalyzed synthesis of propargylamines

Gold catalysis has acquired enormous popularity in the last decades mainly due to the ability of gold catalysts to complex triple bonds and promote a variety of chemical transformations. Among them, gold catalysts have also been used to promote the addition of alkynes to imines and iminium ions leading to the synthesis of propargylamines in a similar fashion to Cu or Zn catalysts. The first gold-catalyzed synthesis of propargylamines has been reported in 2003 by Li and Wei, who described a standard A^3 coupling reaction in which a gold acetylide, formed *in situ* by the reaction of a terminal alkyne with a gold salt, was added to an iminium ion generated by the condensation of an aldehyde with a secondary amine (Scheme 59). Interestingly, the reaction led to the desired propargylamines **280** in high yields (>99%) when both Au^{3+} ($AuBr_3$, $AuCl_3$) or Au^+ (AuI , $AuCl$) were used as catalysts, whilst no conversion was observed with Au^0 . Water proved to be best solvent. On the other hand, when the reaction was carried out in organic solvents (THF, toluene, DMF) the yield drop down to 55-78%. The proposed mechanism of the reaction is reported in Scheme 59. Au(I) activates the C-H of the alkyne leading to the formation of a gold acetylide **282**, which in turn adds on the iminium ion **281** formed by the condensation of the aldehyde and piperidine. In the case of Au(III) catalysts, it has been hypothesized that the Au(I) was generated by the reduction *in situ* of the Au(III) by the alkyne.¹⁹³

Scheme 59. Gold-catalyzed A³ coupling reaction.

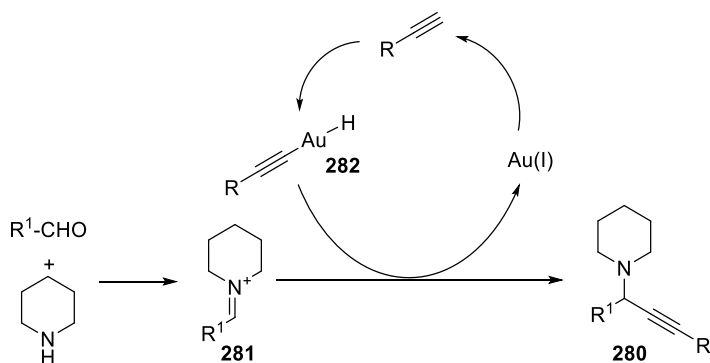
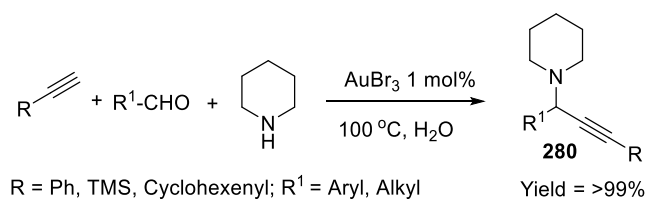

More recently Srinivas and Koketsu reported the synthesis of indole-2-, 3-, or 5-substituted propargylamines using the same Au(III)-catalyzed three-component coupling described by Wei and Li. Indole-propargylamines were obtained in water and with excellent yields.¹⁹⁴

Wong and Che reported a stereoselective version of the gold catalyzed A³ coupling synthesis of propargylamines using Au(III) salen complexes. Firstly, the authors investigated the efficacy of the gold salen complexes **283** and **284** in the coupling of benzaldehyde, phenylacetylene and piperidine. Interestingly, the reaction led to the desired propargylamine in better yields under mild reaction conditions than those reported by Li and coworkers (40 °C instead of 100 °C). Then, the same reaction using chiral proline derivatives as substrates was investigated, leading to propargylamines **287** with excellent dr (<99:1).¹⁹⁵ The same authors later described a new Au(III) complex [Au(C[^]N)Cl₂] **285** for the synthesis of propargylamines under the same reaction conditions.¹⁹⁶ More recently, Wong reported a novel stable bis-cyclometallated Au(III) complex **286** which was successfully used in the synthesis of a variety of propargylamines.¹⁹⁷ (Scheme 60)

Scheme 60. Au(III)-complexes for the synthesis of propargylamines

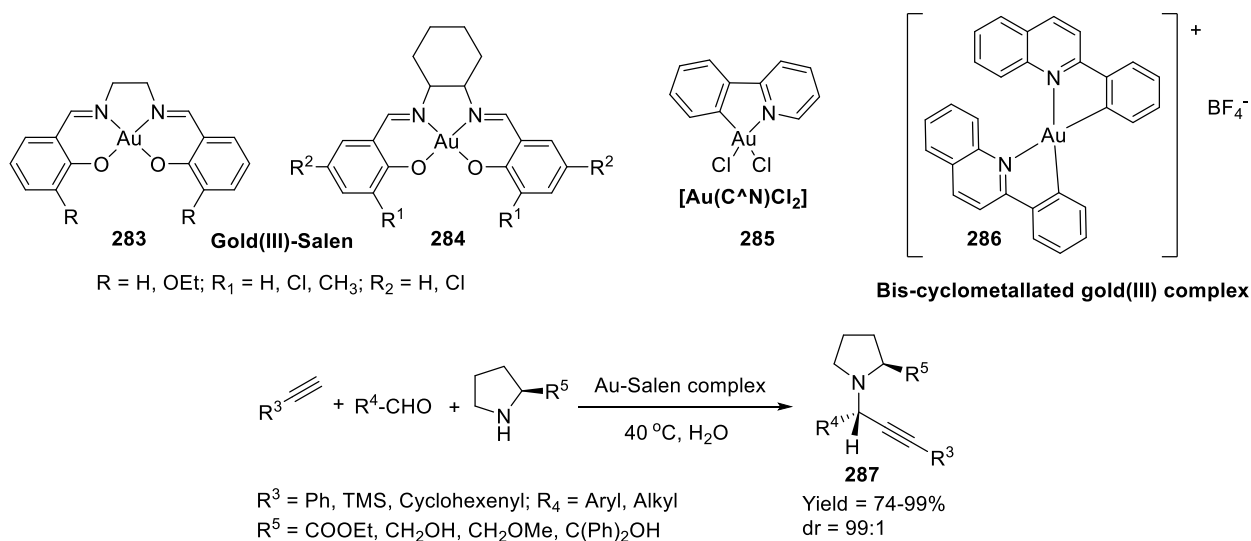

The same three-component reaction using a heterogeneous gold catalyst, namely a layered double hydroxide-supported gold tetrachloride (LDH-AuCl₄), was reported by Kantam *et al.*; propargylamines were obtained with up to 93% yield and the main advantage of this method comes from the possibility to recover and reuse the catalyst several times without losing the catalytic activity.¹⁹⁸ Many other authors reported the synthesis of propargylamines using gold nanoparticles. Recyclable AuNPs have been employed in the synthesis of propargylamines by Kidwai and co-workers (Scheme 61). A series of propargylamines **290** were synthesized in THF at 75-80 °C with excellent yields. The reaction is supposed to proceed through C–H bond activation of the terminal alkyne. The alkynyl-NP intermediate **289** reacts with the iminium ion **288** generated *in situ* from an aldehyde and piperidine to give the corresponding propargylamine and regenerates the Au-nanoparticles for further reactions.¹⁹⁹

Scheme 61. Synthesis of propargylamines using gold nanoparticles.

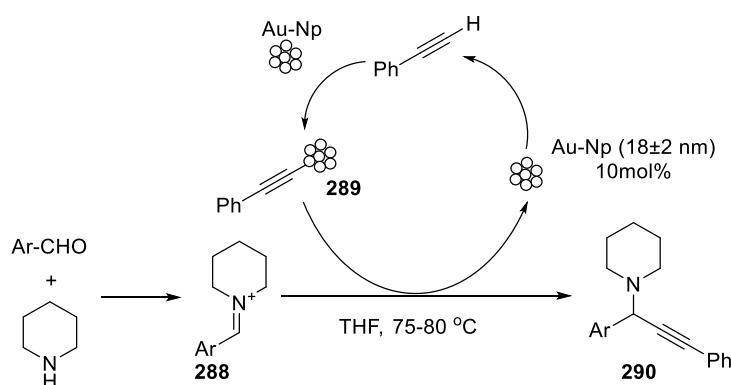

Kantam and co-workers later reported a simple and elegant synthesis of gold nanoparticles *via* counter-ion stabilization of AuCl_4^- on nanocrystalline magnesium oxide support followed by reduction using NaBH_4 . These nanoparticles NAP-Mg-Au(0) were used as a catalyst for the synthesis of propargylamines *via* A^3 coupling reactions. The catalyst contains an ultra-low loading of gold ($0.236 \text{ mol}\%$) and it can be isolated by simple centrifugation and reused for four cycles.²⁰⁰

More recently, Bejar and Scaiano developed an interesting “green” approach to propargylamines using AuNPs supported on ZnO. The selective plasmon excitation of these nanoparticles achieved by LED irradiation in the presence of an aldehyde, amine and alkyne led to propargylamine **292** in 2-3 hours in good to excellent yields. The mechanism proposed is shown in Scheme 62 and it could involve both redox and photothermal components after AuNPs excitation.²⁰¹

Scheme 62. Synthesis of propargylamines by plasmon mediated catalysis with gold nanoparticles on ZnO.

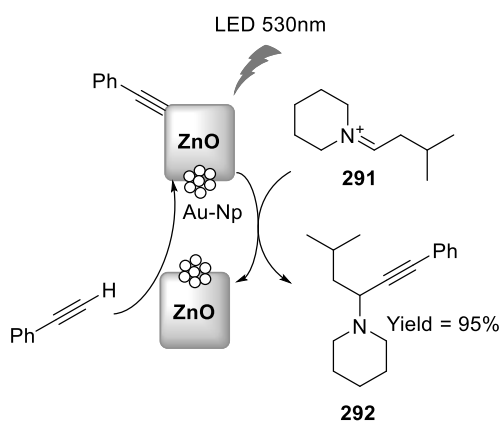

Lili *et al.* described the synthesis of gold functionalized IRMOF-3 catalysts for the one-pot synthesis of structurally divergent propargylamines *via* A^3 coupling without any additives or an inert atmosphere. All the Au/IRMOF-3 catalysts can be easily recycled and used repetitively for at least 5 cycles, while also leading to a variety of propargylamines in good-high yields.²⁰²

Groß *et al.* investigated the A^3 -coupling reaction of different aldehydes, alkynes and amines under heterogeneous catalysis in a two-step micro flow-through system. The authors used a combination of Montmorillonite K-10 (MM K-10) to promote the initial formation of the aldimine and AuNPs on an alumina support (Au-NP@Al₂O₃) to catalyze the second aminoalkylation step. The use of aliphatic aldehydes as well as acyclic aliphatic amines in the flow reaction system led to the desired propargylamines in good to excellent yields.²⁰³

Supported Au(III) on poly(ionic liquid)-coated magnetic nanoparticles (MNP@PILAu) have been recently prepared by Moghaddam *et al.* and used for the synthesis of propargylamines in water by way of an A^3 coupling reaction.²⁰⁴

Additional literature describing the synthesis of propargylamines *via* A^3 coupling reaction using AuNPs as catalysts includes the works of Panwar and co-workers,²⁰⁵ Corma *et al.* who used gold on CeO₂,²⁰⁶ Feiz and Bazgir who developed gold nanoparticles supported on

mercaptoethanol directly bonded to MCM-41²⁰⁷ and Borah *et al.* who used gold nanocrystals stabilized on montmorillonite.²⁰⁸

Finally, the work of Aguilar *et al.* is of significance, in which the one-pot synthesis of propargylamines **293** from terminal alkynes and amines in chlorinated solvents *via* C-H and C-Cl activation catalyzed by gold compounds and nanoparticles was described.²⁰⁹ The plausible mechanism is illustrated in Scheme 63. The AuNP reacts with the alkyne leading to intermediate **294**. Oxidative addition of CH₂Cl₂ leads to **295** which by reductive elimination should afford the intermediate **296**. The latter finally reacts with the amine to yield the propargylamine product **293**. Alternatively, the propargylchloride **296** could give further oxidative addition to Au species, leading to an aurum-complex intermediate which, after addition to the amine and reductive elimination, should afford propargylamine **293**.

Scheme 63. Gold catalyzed synthesis of propargylamines *via* C-H and C-Cl activation.

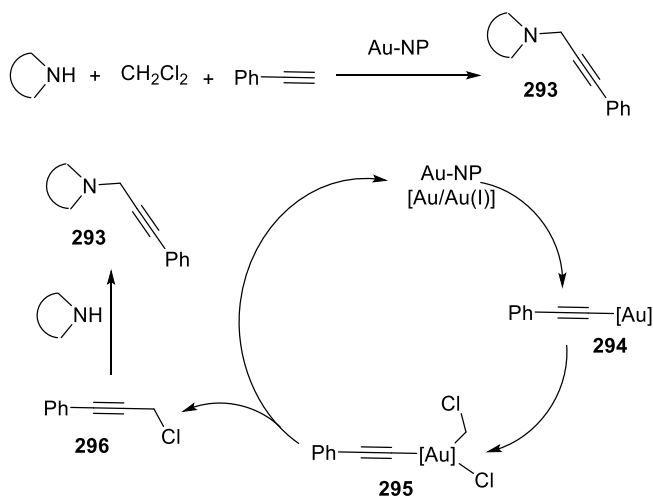

2.7 Silver catalyzed synthesis of propargylamines

As an evolution of their previous work and in an attempt to identify different metal catalysts, Li and co-workers investigated a silver catalyzed A³ coupling of aldehydes, alkyne and secondary cyclic amines, such as pyrrolidines and piperidines, to obtain the corresponding propargylamines **297**. The authors screened several silver catalysts and identified AgI (1.5-3

mol%) as the best to carry out the coupling reaction. A series of propargylamines was obtained in high yields and the reaction carried out in water. The mechanism of the reaction resembles that of the gold-catalyzed A^3 coupling reactions; in this case, the alkyne reacts with Ag^+ to form a silver acetylide, which in turn attacks the iminium ion formed *in situ* from the coupling of the amine and the aldehyde (Scheme 64).²¹⁰

Chan and co-workers later reported the synthesis of propargylamine esters **298** *via* a silver-catalyzed alkynylation of α -iminoesters. Various silver salts were screened, from which AgOTf was found to be the best. Several alkynes were added to *N*-PMP protected α -iminoethyl glyoxalate affording the propargylamines **298** in 79-93% yields (Scheme 64).²¹¹

Scheme 64. Silver catalyzed synthesis of propargylamines 297 and 298.

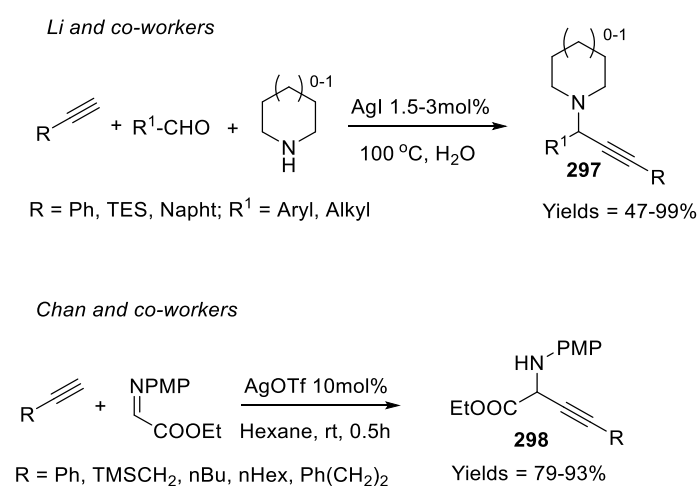

Snapper and Hoveyda described the synthesis of propargylamines using a variety of salts, including silver salts, as catalysts. The authors reported the enantioselective synthesis of propargylamino esters **302** through an Ag-catalyzed asymmetric Mannich reaction of silylketene acetals **300** and alkynyl imines **299**, as summarized in Table 19. The Ag-catalyzed transformation requires a chiral phosphine ligand **301** that can be easily prepared from commercially available materials. Moreover, the enantioselective reaction can be carried out in air without the need for purified solvents. As a result of this approach, a series of

propargylamine derivatives **302** has been synthesized in high yields and obtained with excellent ee, as determined by chiral HPLC analysis.²¹²⁻²¹³

Table 19. Enantioselective synthesis of propargylamino esters through an Ag-catalyzed asymmetric Mannich reaction.

Entry	R	Yield (%)	ee (%)
1	TMS	84	92
2	Ph	91	94
3	PMP	61	92
4	1-Naphth	87	92
5	Cyclopropyl	91	90

Another interesting silver-catalyzed approach to enantioenriched propargylamines has been developed in 2007 by Rueping and co-workers who used a combination of a chiral phosphoric acid **303** and Ag(I) catalyst.²¹⁴ The authors investigated the alkylation of α -imino esters *via* a dual catalysis procedure, in which an enantioselective activation, catalyzed by a Brønsted acid **303**, is combined with a metal-catalyzed alkylation. The propargylamino acid products **304** were isolated in good yields and with excellent er (<96:4). Different metal catalysts (both Ag and Cu) were screened and the best catalyst proved to be AgOAc. Furthermore, the best chiral acid was found to be **303** bearing a 9-phenanthryl group on the naphthyl rings. Scheme 65.

Scheme 65. Enantioselective Brønsted acid and Ag-catalyzed synthesis of propargylamines

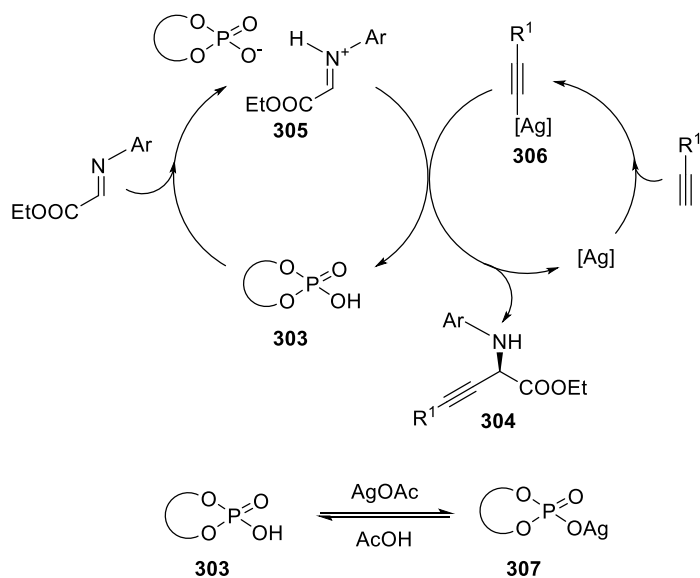
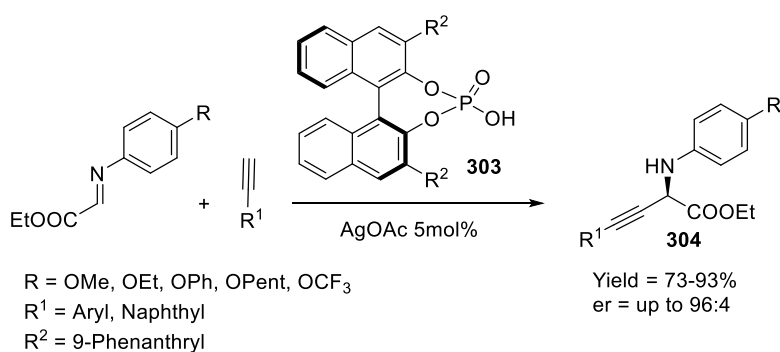

The proposed mechanism of the reaction is illustrated in Scheme 65. Chiral BINOL hydrogen phosphates **303** are excellent Brønsted acid catalysts for chiral ion-pair catalysis. Thus, it is likely that the chiral acid forms a chiral ion-pair imine **305**, which in turn reacts with the silver acetylide **306**. However, the authors hypothesized that an exchange of the metal counter-ion could indeed occur, hence leading to the formation of a chiral silver complex **307**. More recently, Wang and co-workers reported the synthesis of enantioenriched cyclic propargylamines following the Rueping's approach.²¹⁵

A noteworthy procedure for the synthesis of propargylamines has been recently developed by Yin and co-workers *via* the coupling of terminal alkynes with dichloromethane and tertiary

amines in the presence of AgOAc (Scheme 66). The method is simple and allows the synthesis of a variety of tertiary propargylamines **308** in excellent yields. The best catalyst for the reaction was found to be AgOAc, although excellent conversions were obtained when the reaction was performed in the presence of AgBF₄, AgOSO₂C₄F₉ or AgCl. The reaction proceeds in dioxane at 120 °C in the presence of an excess of CH₂Cl₂ (1-15 eq) and a tertiary amine (3 eq). Several tertiary amines were used, leading in all cases to the successful formation of the corresponding alkynylamines. The authors proposed the mechanism outlined in Scheme 66. The methaniminium chloride **309** is formed by the reaction of the tertiary amine with CH₂Cl₂ and then decomposes *via* R¹Cl dissociation to produce methyleneammonium chloride **311**. The latter can behave as a Mannich-reaction intermediate and reacts with the silver acetylide **312** to give the corresponding propargylamine **308**. Experiments using CD₂Cl₂ instead of CH₂Cl₂ as the substrate confirmed that the two protons of the methylene group of dichloromethane are unaffected during the reaction.²¹⁶

Scheme 66. Silver catalyzed coupling of terminal alkynes with dichloromethane and tertiary amines.

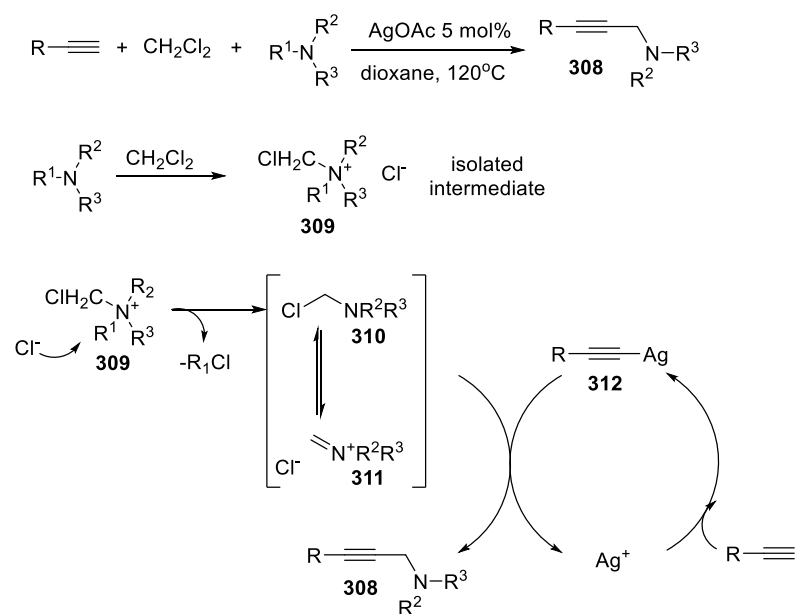

A polymer-supported *N*-heterocyclic carbene (NHC) silver complex **314** has been described by Cai and co-workers as an efficient and recyclable catalyst for the synthesis of propargylamines **315**. The NHC-silver complex catalyst has been prepared *via* a ‘click chemistry’ approach, as illustrated in Scheme 67. The complex **314** efficiently catalyzes the A^3 coupling at room temperature and can be readily recovered and reused for several rounds without significant loss in catalytic activity.²¹⁷

Scheme 67. Synthesis of propargylamines with polymer-supported *N*-heterocyclic carbene (NHC) silver complex **314.**

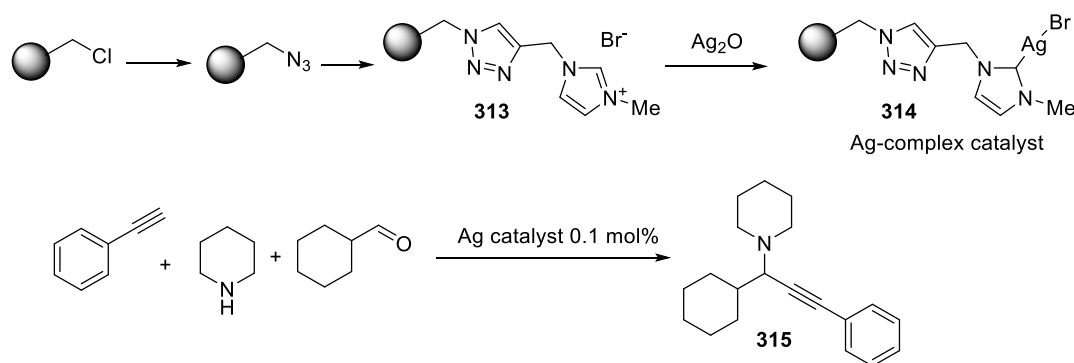

Silver heterogeneous catalytic systems have been developed to synthesize propargylamines. With the aim to develop an environmentally sustainable methodology for the preparation of substituted propargylamines, Maggi and co-workers reported a three-component A^3 coupling between aldehydes, terminal alkynes, and secondary amines catalyzed by AgY zeolite. The catalyst can be easily recovered and reused for at least four cycles without significant decrease in either yield or selectivity.²¹⁸ Another green approach to propargylamines has been recently reported by Sun and co-workers who described the three-component coupling reaction of aldehydes, amines and alkynes catalyzed by silver oxide nanoparticles. Propargylamines were obtained in moderate to high yield under mild aerobic conditions at room temperature.²¹⁹ Recently, Pitchumani and co-workers reported the use of $Ag(I)$ -exchanged MM-K10 clay as an efficient heterogeneous catalyst for the one-pot three-component A^3 coupling of terminal alkynes, amines, and aldehydes (formaldehyde and

benzaldehyde) to yield corresponding propargylamines **316** in water (Scheme 68). The AgI–K10 clay proved to be an efficient and better catalyst in A^3 coupling reactions than other cation-exchanged K10 clays and zeolites. A series of propargylamines was synthesized in high to excellent yields. Moreover, the solid catalyst can be readily recovered by filtration and reused several times without any significant decay in its activity. The proposed mechanism is shown in Scheme 68. The AgI–K10 clay interacts with phenylacetylene by generating an initial Ag(I)–acetylide intermediate **317**, which undergoes subsequent cleavage from one of the oxobridges in clay, affording **318**. The Ag(I)–acetylide intermediate **318** adds to the iminium ion **319** to give the corresponding propargylamine **316** and to regenerate the AgI–K10 catalyst for a further sequence of reactions.²²⁰

Scheme 68. Synthesis of propargylamines using Ag(I)-exchanged K10 montmorillonite clay.

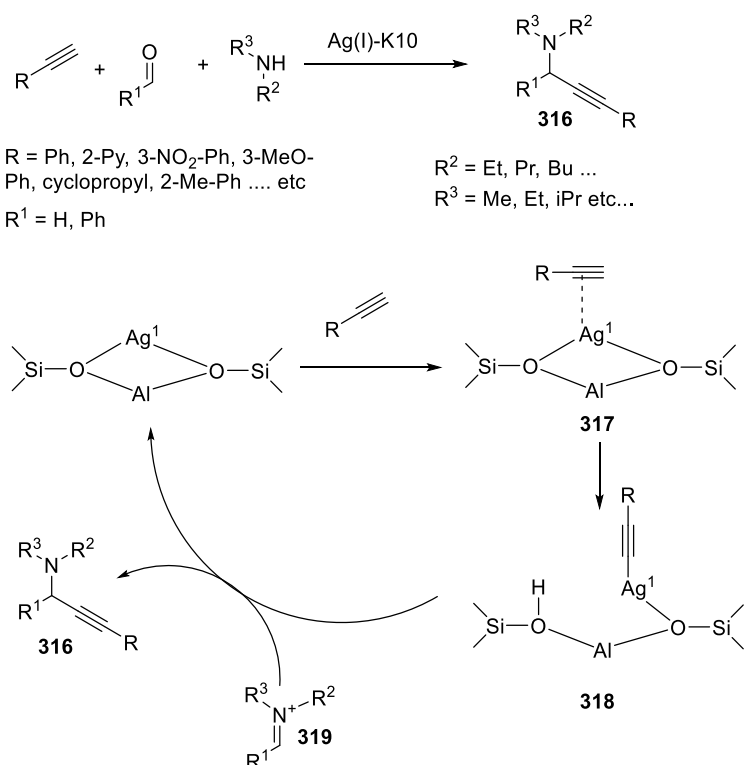

Finally, Movahedi and co-workers described the development of silver nanoparticles immobilized on ionic liquid modified zinc oxide nanoparticles. This combination led to a ZnO-IL/Ag NPs catalyst, which exhibits high catalytic performance in the synthesis of propargylamines through A^3 coupling reaction in water. The catalyst is more efficient when the reaction is carried out in refluxing water and propargylamines can be obtained in excellent yields (>70%).²²¹

2.8 Iridium and rhodium catalyzed synthesis of propargylamines

The first example of iridium catalyzed synthesis of propargylamines was described by Fisher and Carreira in 2001. The authors reported that the addition of TMS-acetylene to aldimines catalyzed by $[\text{IrCl}(\text{COD})]_2$ led to propargylamines **320** in 54-85% yield (Scheme 69).²²² Later, the same authors found that the addition of 2-4 mol% of MgI_2 was beneficial to the reaction conversion. In fact, when MgI_2 is used as additive, the $[\text{IrCl}(\text{COD})]_2$ catalyst loading can be reduced to 0.5 mol%.²²³ On a seminal work aimed at the investigation of the iridium catalyzed three-component coupling reaction of aldehydes, amines and alkynes, Ishii and co-workers reported the synthesis of the propargylamine **321** via $[\text{IrCl}(\text{COD})]_2$ -catalyzed A^3 coupling reaction of butyraldehyde and $n\text{BuNH}_2$ with TMS-acetylene (Scheme 69). It is likely that the reaction proceeds through the oxidative addition of the Ir(I) complex to the terminal C-H bond of TMS-acetylene, followed by insertion of the imine to the resulting Ir-H complex.²²⁴

Scheme 69. Iridium catalyzed synthesis of propargylamines **320** and **321**.

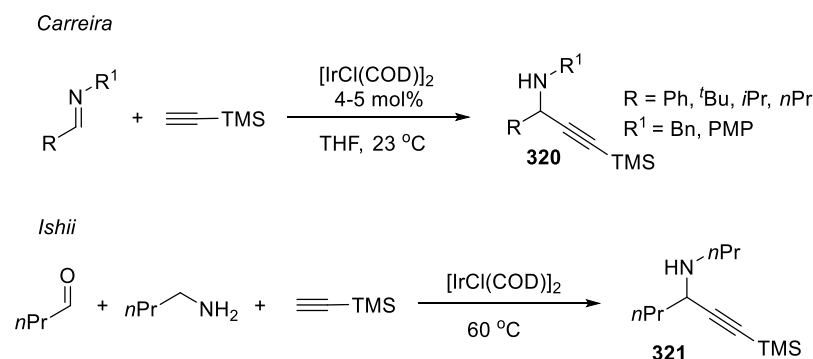

Recently, Oro and co-workers developed a new bimetallic Ir(II) complex **323** as a catalyst for the hydroalkynylation of imines and the synthesis of propargylamines **322** (Scheme 70). A set of propargylamines were synthesized in 59-97% yields. Experimental studies suggested that an unprecedented Ir(II)-based mechanism, also confirmed by DFT calculations, is responsible for the success of this methodology. Firstly, the C–H bond of the alkyne undergoes oxidative addition to one of the Ir centers, with concomitant protonation of the imine. Then, following the binding of the Ir-complex to the protonated imine, the migratory insertion of the imine into the Ir–C(alkynyl) bond takes place. Finally, the desired product is obtained through the dissociation of the propargylamine whilst the bimetallic catalyst is regenerated.²²⁵

Scheme 70. Ir- and Rh-catalyzed approaches to propargylamines **322** and **324**.

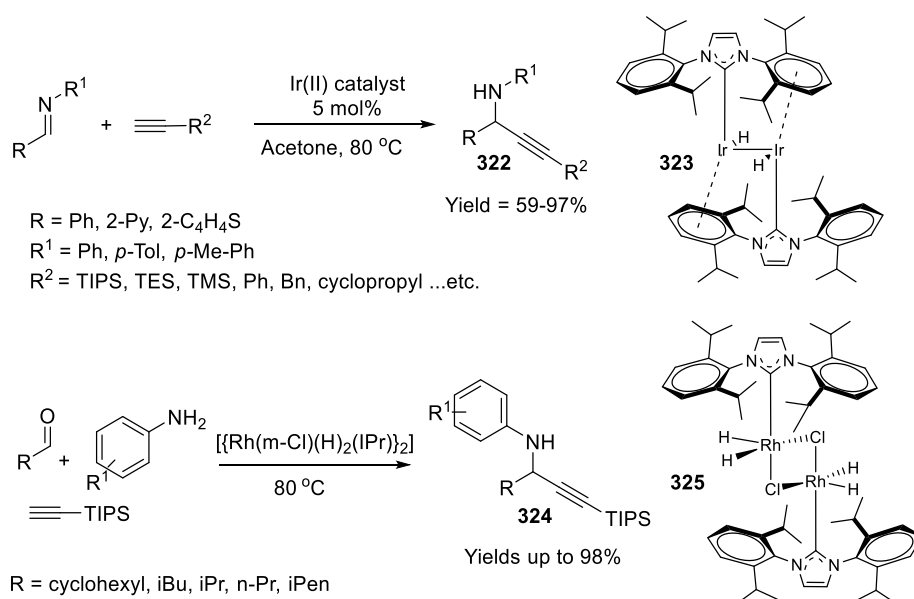

In addition, the same research group also described a rhodium catalyzed A^3 coupling of aldehydes, anilines and alkynes that leads to the synthesis of secondary *N*-aryl-propargylamines **324**. In this work, the catalysts [$\{\text{Rh}(\text{m-Cl})(\text{H})_2(\text{IPr})\}_2$] **325** was used and compounds **324** were obtained in excellent yields of up to 98% (Scheme 70).²²⁶

2.9 Indium and zirconium catalyzed synthesis of propargylamines

In(III) salts have attracted a great interest in organic synthesis in the last few decades due to their multiple advantages in terms of water stability, recyclability, operational simplicity, and their strong tolerance to oxygen- and nitrogen-containing substrates and functional groups when compared to other conventional Lewis acids.

The first example of an indium-catalyzed synthesis of propargylamines has been reported in 2005 by Sakai and Konakahara, who successfully reported the reaction of terminal alkynes with *N,O*- or *N,S*-acetals **326** leading to propargylic amines **327** (Scheme 71). It has been hypothesized that the indium catalyst plays a dual role, firstly in coordinating to the alkyne π -bond to facilitate the abstraction of a terminal hydrogen and subsequently activating the acetals to favor the attack and formation of the propargylamines **327**.²²⁷

Scheme 71. Indium catalyzed alkylation of *N,O*- or *N,S*-acetals.

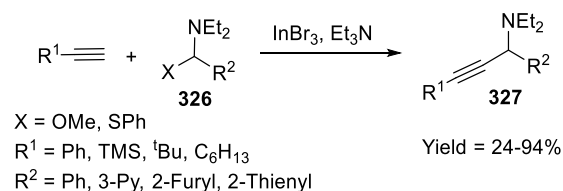

In 2009, Wang and co-workers described the A^3 coupling of an aldehyde, a secondary amine and an alkyne catalyzed by InCl_3 . A number of In(III) and In(I) salts was screened and InCl_3 was shown to be the best catalyst for A^3 coupling reactions. InCl also proved to be an excellent catalyst in the synthesis of propargylamines *via* the A^3 coupling reaction. However,

the authors preferred to use the InCl_3 since it is more cost effective compared with InCl . Different solvents were also investigated and the best conversion was observed when toluene was used. A variety of propargylamines **328** were synthesized in 68-99% yields (Table 20).²²⁸

The proposed mechanism is illustrated in Scheme 72.

Table 20. In-catalyzed A^3 coupling.

Entry	R	R ¹	NHR ² R ²	Yield (%)
1	Ph	<i>i</i> Pr	NHBn ₂	98
2	<i>p</i> -Me-Ph	<i>i</i> Pr	NHBn ₂	99
3	<i>p</i> -F-Ph	<i>i</i> Pr	NHBn ₂	97
4	<i>p</i> -Cl-Ph	<i>i</i> Pr	NHBn ₂	98
5	<i>n</i> -C ₈ H ₁₇	<i>i</i> Pr	NHBn ₂	89
6	<i>n</i> -C ₆ H ₁₃	<i>i</i> Pr	NHBn ₂	87
7	Ph	Ph	NHBn ₂	99
8	Ph	<i>p</i> -Me-Ph	NHBn ₂	97
9	Ph	H	NH <i>i</i> Pr ₂	78
10	Ph	Ph	Piperidine	96

The catalyst InCl_3 first reacts with the terminal alkyne to form a stable In(III) -acetylide **329**. In the first step, the plausible release of HCl seems to accelerate the formation of the iminium salt intermediate **330** formed from the reaction of the aldehyde and the secondary amine. Subsequently, the indium-acetylide intermediate reacts with the iminium salt generated *in situ* to give the corresponding propargylamine **328** and regenerates the In(III) catalyst.

Scheme 72. Mechanism of the In-catalyzed A³ coupling reaction.

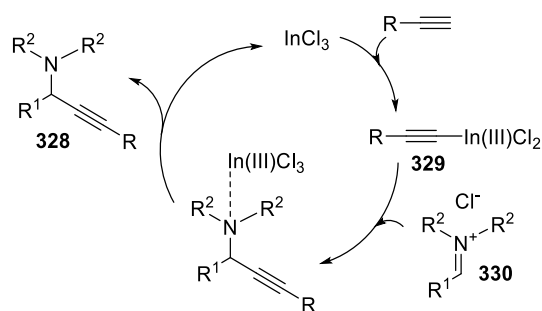

In parallel, Yadav *et al.* reported a similar approach to propargylamines using InBr₃ as a catalyst. The reactions proceed smoothly in toluene at 80 °C, using both aromatic and aliphatic aldehydes as substrates and afforded propargylamines in 70-95% yields.²²⁹

Ji and Xu used InBr₃ as the catalyst in the synthesis of *N*-hydroxy-propargylamines through the alkylation of nitrones with terminal alkynes. The reaction was performed under mild conditions in the presence of DIPEA as an external base and using 25 mol% of the catalyst. In this manner, *N*-hydroxy-propargyl amines were obtained with up to 95% yields.²³⁰

More recently, Schneider and co-workers described the synthesis and the use of a silica-xerogel-supported indium(III) composite (In/SiO₂) in the synthesis of propargylamines *via* an A³ coupling. The In(III) ion was tethered to the silica matrix surface, forming a Si-O-InCl_x structure (x = 1 or 2). The In/SiO₂ composite showed a specific surface area and porosity that allowed its application as heterogeneous catalyst in one-pot multicomponent A³ coupling reactions under solvent-free conditions with both conventional and microwave heating. A range of propargylamines were synthesized using this approach in 58-94% yields.²³¹

Nano indium oxide has also been used by Rahman *et al.* as a catalyst for the synthesis of propargylamines **331** *via* C-H and C-Cl bond activation of alkynes and dichloromethane respectively. The reaction proceeds in DMSO at 65 °C and in the presence of DABCO as shown in Scheme 73.²³²

Scheme 73. Synthesis of propargylamines 331 with nano In₂O₃.

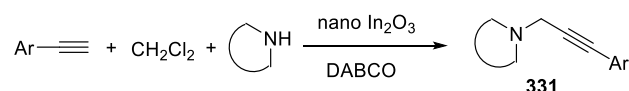

Zirconium has found less applications in the preparation of propargylamines and generally in organic synthesis. However, the work reported in 2003 by Snapper and Hoveyda is noteworthy, in which a Zr-catalyzed method for the synthesis of enantiomerically enriched propargylamines **334** with up to 90% ee was described (Table 21). The method consists of the enantioselective addition of a range of mixed alkynylzinc reagents to various arylimines **332**, promoted by the peptidic chiral ligand **333** complexed with a zirconium salt, Zr(O-*i*-Pr)₄·HO-*i*-Pr. The combination of these led to the *in situ* formation of the real catalyst of the reaction, which allowed a variety of *N*-*O*-anisidyl-propargylamines **334** to be synthesized in 69-82% yields.²³³

Table 21. Zr-catalyzed synthesis of propargylamines 334.

Entry	R	Yield (%)	ee (%)
1	Ph	83	90
2	4-Cl-Ph	90	81
3	4-Br-Ph	84	69
4	4-MeO-Ph	69	86
5	1-naph	77	86
6	2-naph	85	81
7	2-Furyl	72	82

In parallel, the same authors reported a similar Zr-catalyzed protocol for the enantioselective synthesis of propargylamines **335** which, in contrast to the previous approach, involves the addition of alkylmetal reagents (e.g. dialkyl-zinc) to alkynylimines. The reaction of a series of aldehydes and anilines with different dialkylzinc reagents afforded propargylamines **335** in high yields and with high ee (Scheme 74).²³⁴

Scheme 74. Zr-catalyzed synthesis of propargylamines 335.

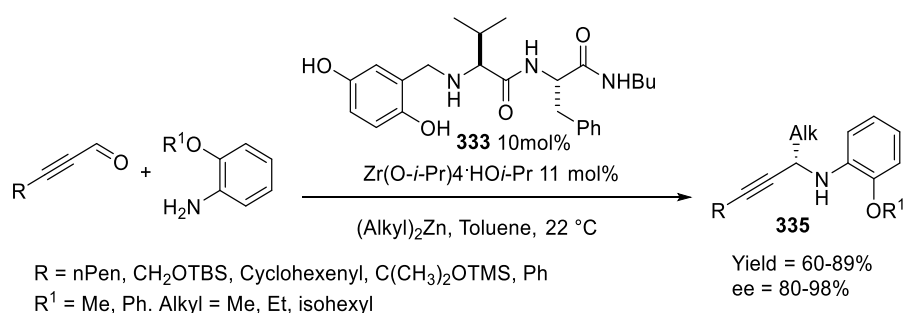

2.10 Various metal catalyzed synthesis of propargylamines: nickel, iron, cobalt, bismuth, manganese

As shown in the previous sections, the alkyne C-H bond can be activated by various homogeneous and heterogeneous metal catalysts, which leads to the formation of metal acetylides that can be exploited in the synthesis of propargylamines. Methods using metal catalysts such as Ni, Fe, Bi, Co and Mn, which are rather unusual in the synthesis of propargylamines, have been also described in the literature.

A three-component A³ coupling of aldehydes, alkynes and secondary amines catalyzed by BiCl₃ has been reported by Teimouri *et al.* in 2012. The propargylamine products **336** were obtained in high yields and in relatively short reaction time (<100 min). Different Bi(III) salts were also investigated, although lower yields were generally recorded (Scheme 75).²³⁵

Scheme 75. BiCl₃ catalyzed A³ coupling reaction

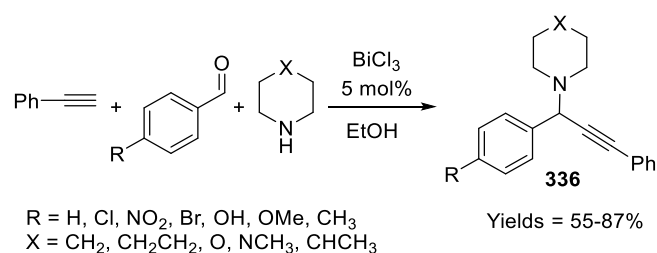

A cobalt-catalyzed A³ coupling using terminal alkynes has been described by Li and co-workers, leading to the synthesis of a wide range of propargylamines in high yields. The authors screened several Co salts and generally obtained propargylamines in low yields. Interestingly, when the reaction was performed in the presence of PPh₃, an improvement in the yield was observed. Better yields were also obtained when the complex CoCl₂(PPh₃)₂ was used as a catalyst. Two plausible mechanisms of actions have been proposed, one involving a Co(I)–Co(III)–Co(I) catalytic cycle in which a C–H insertion of Co(I) generated *in situ* from Co(II) occurs, leading to the formation of an alkynyl-Co(III)-hydride complex, and the other where Co(II) forms a Co(II)-acetylide intermediate without any change in the cobalt valency.²³⁶

Zhou and co-workers developed a cobalt-catalyzed alkyne–dihalomethane–amine coupling as an efficient protocol to access propargylamines **337**. The method is based on the dual activation of the alkyne C–H bond and the dihalomethane C–Hal bond, as shown in Scheme 76. CoBr₂ was found to be the best catalyst, whilst CH₂Cl₂, CH₂Br₂ and CH₂I₂ proved to be all good coupling partners affording the propargylamine products in high yields. A plausible mechanism involving a Co(I)–Co(III)–Co(I) catalytic cycle was proposed by the authors. Initially, the Co(I) catalyst is generated *in situ* from Co(II), which might be reduced by alkynes or bases. The insertion of Co(I) into the C–H bond of the terminal alkyne gives alkynyl-cobalt complex **338**. Oxidative addition of CH₂Cl₂ to intermediate **338** forms Co(III) species **339**, which subsequently undergoes reductive elimination to afford propargylchloride

340 regenerating the Co(I) catalyst. The reaction of propargylchloride with an amine finally gives the corresponding propargylamines **337**.²³⁷ Scheme 76.

A similar protocol was developed earlier by He and co-workers who described a FeCl₃ catalyzed coupling of alkynes, dichloromethane and a secondary amine for the synthesis of propargylamines (Scheme 76). The authors carried out the reaction at 100°C in MeCN using 1,1,3,3-tetramethylguanidine (TMG) as a base. The proposed mechanism proceeds by the *in situ* formation of the Fe(II) catalyst from Fe(III).²³⁸

Later, Bhanage and co-workers reported the same three-component reaction for the synthesis of propargylamines **337** using Ni(py)₄Cl₂ as a catalyst and bipyridine as a base (Scheme 76).²³⁹

Scheme 76. Co-, Fe- and Ni-catalyzed synthesis of propargylamines via C-H and C-Cl activation.

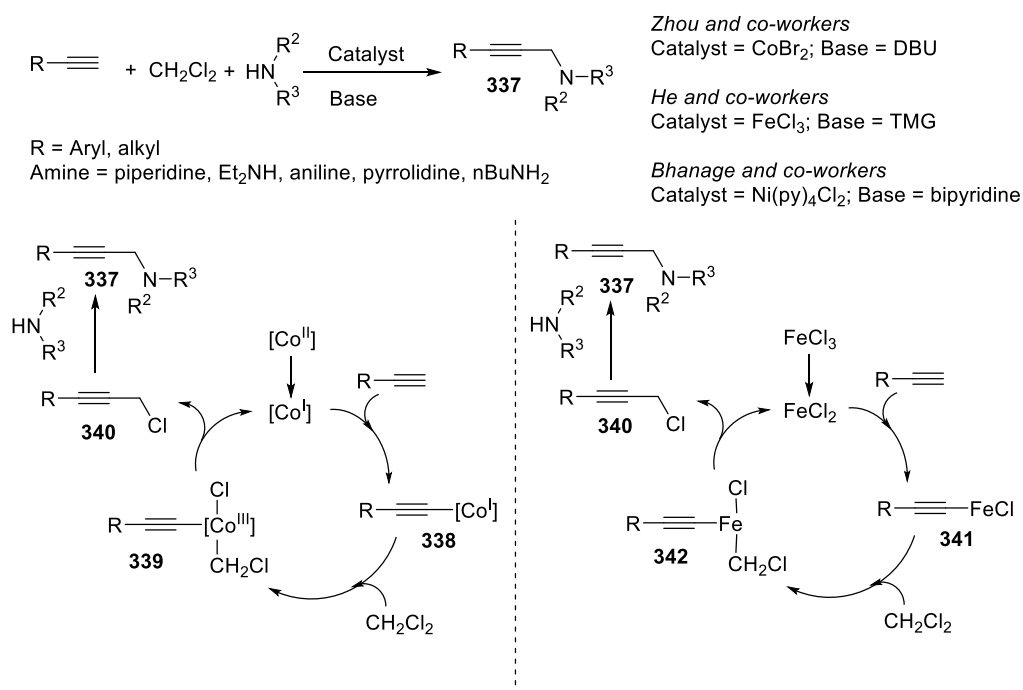

Recently, the preparation of superparamagnetic Fe₃O₄ nanoparticles (NPs), which exhibit excellent catalytic efficiency in A³ coupling for the preparation of propargylamines, has been described by Bhalla and co-workers. A series of propargylamines **343** was synthesized

efficiently from a range of aldehydes, including *p*-NO₂-benzaldehyde which in general reacts slowly in A³ couplings. In addition, the authors also explored the catalytic efficiency of generated Fe₃O₄ NPs in the aldehyde-free synthesis of propargylamines **344** from *N*-dimethylanilines. A plausible mechanism for this transformation is illustrated in Scheme 77. The Fe₃O₄ NPs is envisaged to be able to activate both the alkyne and the dimethyl-arylamine. The latter would be converted into the electrophilic iminium **346**, which is attacked by the Fe₃O₄-NPs-alkyne complex and thus leads to the formation of the propargylamine **344**.²⁴⁰

Scheme 77. Synthesis of propargylamines using superparamagnetic Fe₃O₄ nanoparticles.

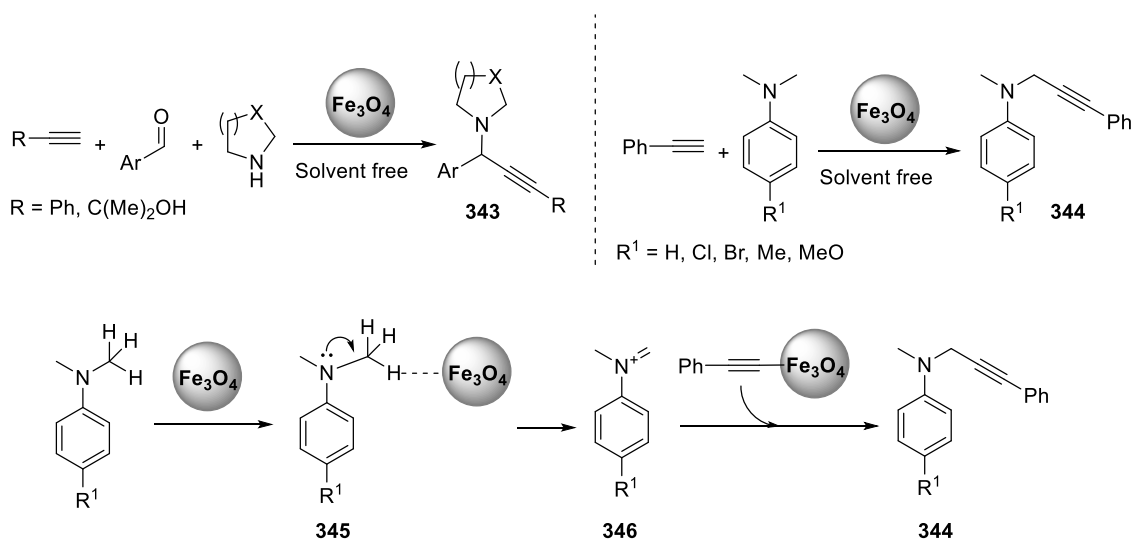

Co₃O₄ Nanoparticles have been also prepared and used in the A³ coupling of alkynes, amines and aldehydes by Bhatte *et al.* affording propargylamines in good yields. The catalyst can be recycled up to ten times and reused without any loss of catalytic activity.²⁴¹

Sharma *et al.* developed an efficient heterogeneous silica nanosphere-supported iron catalyst (SiO₂@APTES@DAFO-Fe) which was used in the synthesis of propargylamines *via* a one-pot three-component coupling reaction of terminal alkynes, dihalomethane and secondary amines.²⁴² The efficacy of SiO₂@APTES@DAFO-Fe was compared with the performance

reported catalysts. The SiO₂@APTES@DAFO-Fe catalyst exhibited much better results in terms of catalytic activity, reaction conditions and superior reusability when compared with the approach from He and co-workers.²³⁸ This may be due to the higher surface to volume ratio of the nano-catalyst in contrast with other bulk catalytic systems.

Finally, the synthesis of propargylamines *via* an A³ coupling reaction in the presence of MnCl₂ as a catalyst was reported by Afraj *et al.*. This methodology is efficient for reactions involving aromatic, aliphatic, and heterocyclic aldehydes and provides access to propargylamines **347** in good yields (Table 22).²⁴³ More recently, the same authors also developed a SnCl₂ catalyzed A³ coupling synthesis of propargylamines.²⁴⁴

Table 22. Mn-catalyzed A³ coupling reaction.

Entry	R	R ¹	Amine	Yield (%)
1	Ph	Ph	Piperidine	98
2	Ph	Ph	Morpholine	90
3	iPr	Ph	Morpholine	96
4	3-Thienyl	Ph	Morpholine	93
5	Ph	<i>p</i> -MeO-Ph	Piperidine	97
6	<i>c</i> -hexyl	Ph	Piperidine	95
7	Et	Ph	Piperidine	96
8	<i>p</i> -Cl-Ph	Ph	Piperidine	96
9	1-Naphthyl	Ph	Piperidine	96
10	Pent	Ph	Piperidine	97
11	Hex	Ph	Piperidine	96

2.11 Synthesis of propargylamines using boronic acids and alkylboronates

Boronic acids and alkylboronates have been widely used in the synthesis of allylamines and homoallylamines, whilst only a few examples describing their use in the synthesis of propargylamines have been reported. Wu and Chong reported that binaphthol-based alkynylboronates **349** were able to perform the enantioselective alkynylation of *N*-acylaldimines **348**. Exploiting the structural similarity between *N*-acylimines and enones, the authors reacted **348** with alkynylboronates **349** through a 1,4-addition obtaining enantioenriched propargyl amides **350** in high yields and with high ee, as highlighted in Table 23. The enantioselectivity of the reaction, determined by chiral HPLC, was explained by assuming that the reaction proceeds through two possible cyclic six-membered chair transition states. As shown in Scheme 78, it is evident that the Ph substituents on the binaphthol have a key role in destabilizing transition state **A** in favor of the six-membered ring transition state **B**.²⁴⁵ The methodology has then been applied for the total synthesis of (-)-*N*-acetylcolchinol. The absolute configuration of the propargylamines was determined by analogy with (-)-*N*-acetylcolchinol.

Table 23. Asymmetric synthesis of propargylamides with alkynylboronates 349.

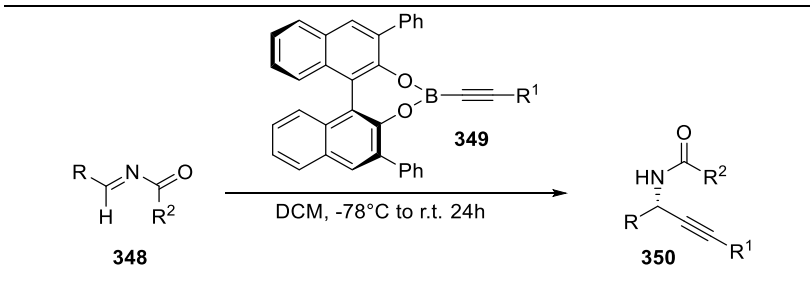

Entry	R	R ¹	R ²	Yield (%)	ee (%)
1	Ph	<i>n</i> -C ₆ H ₁₃	Me	75	92
2	4-Cl-Ph	<i>n</i> -C ₆ H ₁₃	Me	72	91
3	4-MeO-Ph	<i>n</i> -C ₆ H ₁₃	Me	81	92
4	4-Me-Ph	<i>n</i> -C ₆ H ₁₃	Me	76	92
5	2-Me-Ph	<i>n</i> -C ₆ H ₁₃	Me	78	99

6	1-Naphthyl	<i>n</i> -C ₆ H ₁₃	Me	70	99
7	PhCH=CH	<i>n</i> -C ₆ H ₁₃	Me	75	67
8	Ph	Ph	Me	85	92
9	4-Br-Ph	Ph	Me	75	92
10	PhCH=CH	Ph	Me	80	93
11	Ph	<i>n</i> -C ₆ H ₁₃	Ph	84	64
12	Ph	<i>n</i> -C ₆ H ₁₃	OBn	85	67

Scheme 78. Transition state in the alkylation of *N*-acylimines with alkynylboronates.

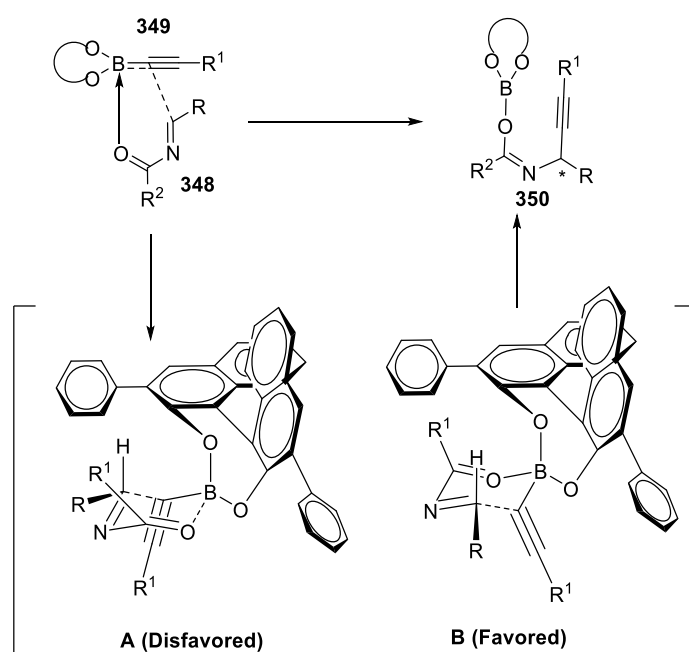

An interesting example on the use of enantiopure alkynyl boranes **352** as alkynylating agents has been reported by Soderquist and co-workers in the synthesis of propargylamines **354**. The authors treated the enantiopure 10-substituted-9-borabicyclo[3.3.2]decane (10-*R*-9-BBDs) **351** with different alkynyl-Grignard reagents leading to alkynyl boranes **352**. These latter were then added to *N*-acylimines **353** affording, in the presence of pseudoephedrine as a ligand, the (*R*)-propargylamines **354** as the major products with 56–99% ee (Scheme79).²⁴⁶

Scheme 79. Addition of alkynyl boranes 352 to *N*-acylimines.

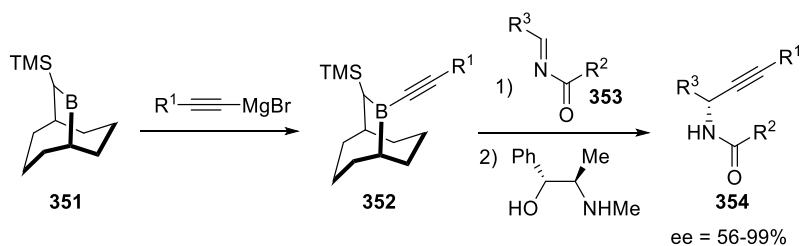

More recently, Sun and co-workers described a catalyst-free Petasis/decarboxylative domino reaction using boronic acids as substrates. The authors reacted primary amines in a Petasis reaction with formaldehyde and a boronic acid to form a reactive amine *in situ*, followed by a metal-free decarboxylative A^3 coupling reaction with propiolic acid. As shown in Scheme 80, the amine first reacts with formaldehyde giving rise to the iminium intermediate **356**. This latter is then alkylated by reaction with the boronic acid, leading to the corresponding alcohol **357**. Subsequent protonation and dehydration of **357** in the presence of propiolic acid results in the iminium intermediate **358** which finally reacts with the propiolate leading to the expected propargylamine **355** through final decarboxylation. In this manner, several propargylamines were synthesized chemoselectively in high yields.²⁴⁷ A similar approach was also described later by Wang *et al.*²⁴⁸⁻²⁴⁹

Scheme 80. Synthesis of propargylamines *via* Petasis/decarboxylative domino reaction with boronic acids.

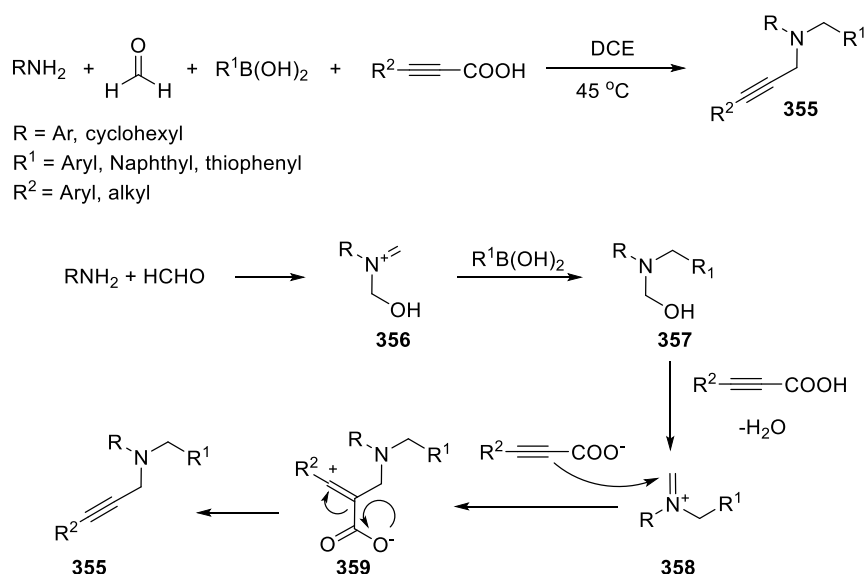

Finally, Jiang *et al.* reported the one-pot synthesis of *N*-aryl propargylamines through the reaction of aromatic boronic acid with aqueous ammonia and propargyl bromide under microwave-assisted conditions. The copper catalyst Cu₂O was also used to promote the coupling of aromatic boronic acids with aqueous ammonia and the following propargylation by propargyl bromide.²⁵⁰

2.12 Synthesis of propargylamines through metal-free reactions

Although propargylamines are generally synthesized *via* metal-catalyzed reactions, a few metal-free approaches have been recently developed. A metal-free synthesis of propargylamines offers undeniable advantages, such as a reduction in cost, in addition to obvious environmental benefits from a synthetic perspective. Sreedhar and co-workers recently found that the standard synthesis of propargylamines *via* three-component coupling reaction of methylene chloride, alkynes and amines could be performed without a metal catalyst or any additional base (Scheme 81).²⁵¹ The authors suggested that the operative temperature of 70 °C is sufficient to allow the piperidine to displace one of the two chlorines

from DCM and to form a chloromethylpiperidine intermediate. The following nucleophilic substitution of the halide by an alkyne and subsequent deprotonation would then lead to the propargylamine product **360**.

Similarly, Lee and co-workers found that phenyl propiolic acid can be decarboxylated to produce phenyl acetylene in the absence of metal when reacted with an amine and formaldehyde at 65 °C, to also afford **360** as shown in Scheme 81.²⁵²

Scheme 81. Metal free syntheses of propargylamines 360.

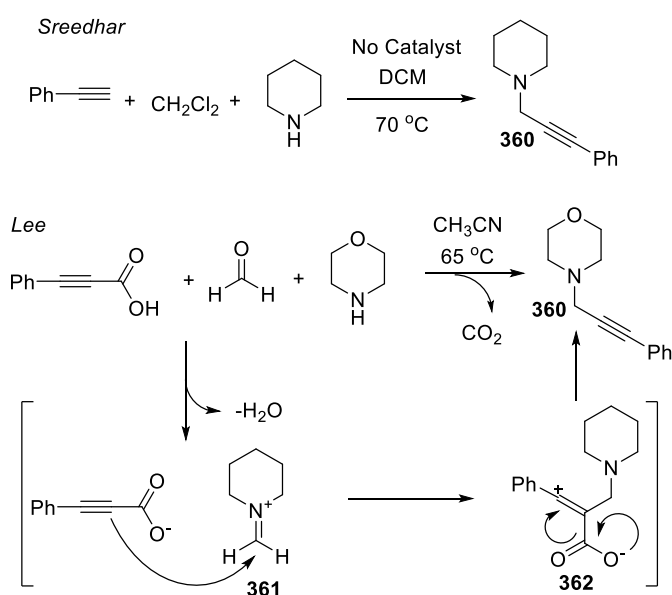

More recently, the Lee's group implemented this reaction to a continuous-flow reaction system. Propargylamines were synthesized in high yields using the above described method in water at 140 °C.²⁵³

Basu and co-workers reported a metal free A³ coupling of salicylaldehyde with amines and alkynes to afford 1-aryl-propargylamines. In this work, the authors investigated the effect of the hydroxy group of the salicylaldehyde in A³ coupling reactions which seems able to activate the Csp-H bond of the terminal alkyne in place of a metal catalyst. According to their hypothesis, the salicylaldehyde reacts with a secondary amine, leading to the formation of the iminium intermediate **363**. After the formation of the iminium ion **363**, the hydroxy

group in the *ortho* position may undergo deprotonation to form an unstable *o*-quinonoid intermediate **364**, which presumably activates the sp carbon (C–H) of the alkyne *via* H-bond formation. This makes the alkyne more nucleophilic and thus able to attack the electrophilic iminium carbon, leading to the formation of the A³ coupling propargylamine products **365** (Scheme 82). To confirm this hypothesis, the authors carried out parallel experiments. For example, the inability of the *o*-methoxybenzaldehyde and *p*-hydroxybenzaldehyde to undergo a similar reaction under metal-free conditions could be explained by this mechanism. The *p*-hydroxybenzaldehyde might give rise to the corresponding *p*-quinonoid species but does not activate the sp carbon (C–H) of the alkyne. Moreover, as the reaction does not occur in protic solvents like ethanol, it seems feasible that the hydroxy group of salicylaldehyde can form a hydrogen bond with the protic ethanol solvent. In this manner, the possibility of activating the sp carbon (C–H) of the alkyne is remarkably reduced. Furthermore, the fact that reactions with primary amines, like cyclohexylamine and benzylamine, produced only the imine and not the A³-coupled product, shows that imines are less efficient than the iminium species when reacting with terminal alkyne under the reaction conditions.²⁵⁴

Scheme 82. Metal free A³ coupling of salicylaldehyde with amines and alkynes.

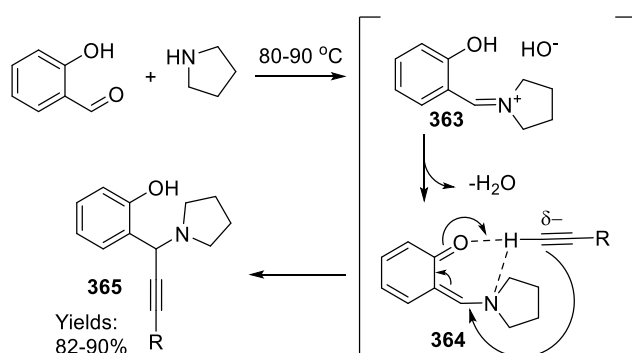

Alkynes: R= Ph, *p*-MePh, *o*-Br-Ph, *p*-BrPh

Amines: morpholine, piperidine, pyrrolidine, 4-Bn-piperidine

2.13 Synthesis of propargylamines *via* aldehyde to alkyne homologation

Among the different methods known for the synthesis of alkynes, the Corey-Fuchs reaction, namely the homologation of an aldehyde to a terminal alkyne, represents one of the most widely used approaches. An example of Corey-Fuchs reaction used for the synthesis of propargylamines was reported by Boys in 1998. The azetidinone aldehyde **366** was prepared from *L*-aspartic acid and then treated under standard Corey-Fuchs conditions with $\text{CuBr}_4/\text{PPh}_3$ and BuLi affording the alkynyl derivative **368**. Treatment of **368** with hydrogen chloride in ethanol gave finally the desired propargylamino derivative **369** (Scheme 83).²⁵⁵

More recently, He and Yudin reported the synthesis of strained propargylamines *via* aldehyde-alkyne homologation. The aziridine aldehyde dimer **370** exists in equilibrium with the aldehyde **371**, which can be used as a substrate for the Corey-Fuchs reaction. However, the use of BuLi led to the decomposition of the material, as no formation of the alkynyl aziridine **373** was observed. On the other hand, treatment of **371 with the Bestmann–Ohira reagent **372** in anhydrous methanol in the presence of K_2CO_3 led to the aziridine **373** (namely a cyclic propargylamine) in excellent yields (Scheme 83).²⁵⁶**

Scheme 83. Aldehyde to alkyne homologation reactions.

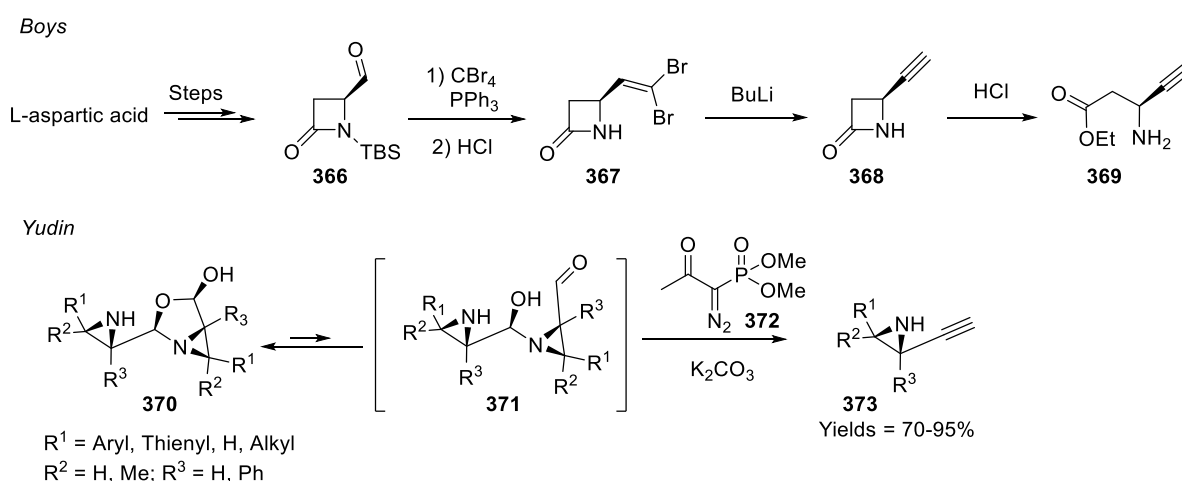

2.14 Organocatalyzed synthesis of propargylamines.

Relatively few examples for the synthesis of propargylamines using organocatalytic methods have been described in the literature. These approaches resemble the Ag-catalyzed reaction previously developed by Hoveyda and Snapper²¹²⁻²¹³ where propargylamines are synthesized through the addition of carbon nucleophiles to alkynyl imines. Maruoka and co-workers developed a stereoselective Mannich-type reaction of *in situ* generated C-alkynyl imines **380** with acetylacetone²⁵⁷⁻²⁵⁸ and aliphatic aldehydes²⁵⁹ catalyzed by chiral Brønsted acids **376** (Scheme 84). Interestingly, a racemic version of the reaction can be performed in the presence of Cu(OTf)₂ in place of the Brønsted acid catalyst. Mechanistic investigations revealed that the Mannich-type reaction of aminal **374** proceeds through the reversible and gradual generation of imines intermediate **380** (or the corresponding iminium salt) by acid-catalyzed elimination of BocNH₂ and the subsequent carbon–carbon bond formation. In these processes, the acid catalyst played a double role, favoring the imine generation as well as the acceleration of the Mannich-type reaction.

Scheme 84. Synthesis of propargylamines with chiral Brønsted acids.

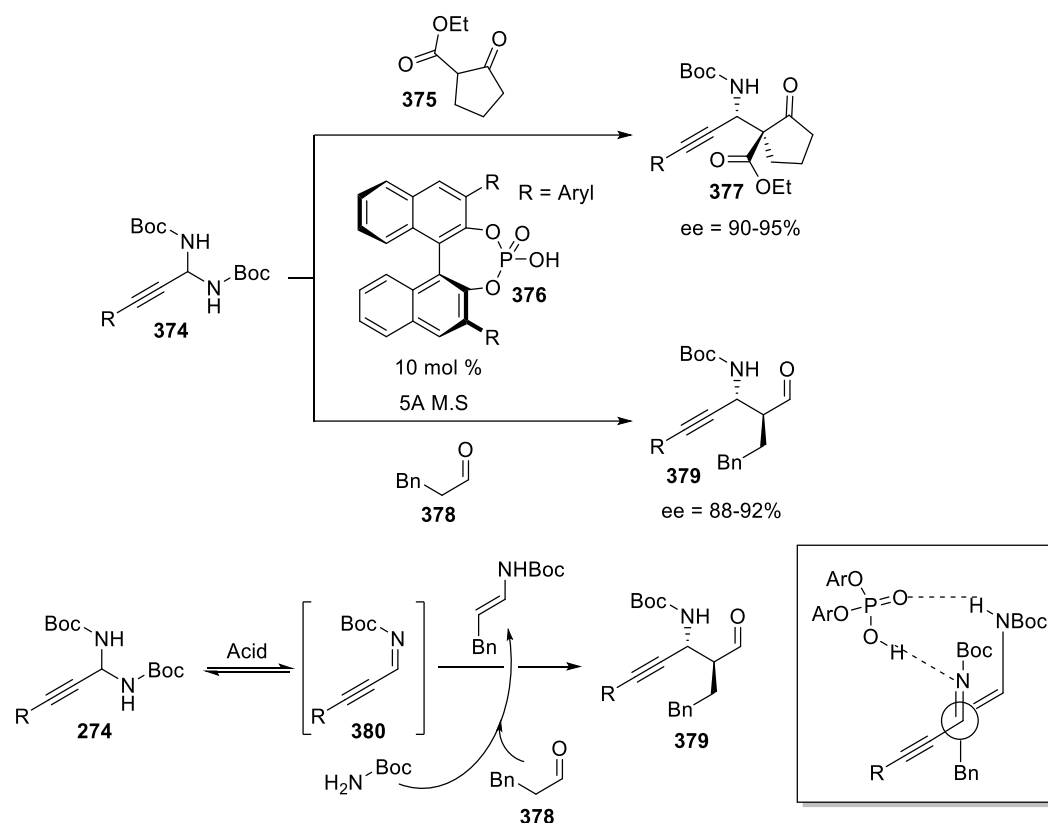

Another similar organocatalytic approach to propargylamines has been developed by Palomo and co-workers, who combined a proline-based catalyst and a Brønsted acid to promote the Mannich reaction of aldehydes with inactivated alkynyl imines (Table 24). The dialkylprolinol ether **381** was found as the best organocatalyst and when combined with *p*-nitrobenzoic acid (PNBA) led, after reduction of the aldehyde, to propargylamines **382** with good yields (typically 70–75%). Propargylamines were obtained with *anti:syn* ratios greater than 90:10 and ee values typically above 95%.²⁶⁰ A rationale for the observed stereochemistry of catalytic reaction was hypothesized on the basis of previously proposed models for enamine mediated asymmetric Mannich reactions. The plausible transition state models **TS-*anti*** and **TS-*syn*** (Table 24) were proposed to account for the formation of the corresponding Mannich adducts *anti* and *syn* **382**. The preference for *anti* product over *syn* might be

explained assuming unfavourable interactions in **TS-*syn*** between the bulky substituents on the pyrrolidine ring and both the aromatic ring of benzoic acid and the alkynyl moiety of the imine.

Table 24. Synthesis of propargylamines with the proline catalyst 381.

Entry	R	R ¹	R ²	Yield (%)	<i>anti</i> : <i>syn</i>	ee (%)
1	Ph	Ph	CH ₃	72	90:10	96
2	Ph	3-Cl-Ph	CH ₃	80	93:7	97
3	Ph	3-MeO-Ph	CH ₃	90	90:10	96
4	<i>c</i> -C ₆ H ₁₁	4-MeO-Ph	CH ₃	60	90:10	97
5	Ph	4-MeO-Ph	CH ₂ Bn	72	92:8	98
6	TMS	4-MeO-Ph	CH ₂ CH=CH ₂	77	90:10	97
7	Ph	4-Cl-Ph	Et	65	90:10	99

Wang *et al.* recently described the asymmetric synthesis of *syn*-propargylamines using a Brønsted base organocatalyst. The *N*-Boc-*N,O*-acetals **383**, prepared from ynals by treatment with BocNH₂ in the presence of Ti(OEt)₄, was reacted under mild conditions with malonate (thio)esters, malonate esters and β-keto-esters in the presence of different organocatalysts **388-389**. When the acetal **383** was reacted with the malonate (thio)ester **384** in the presence of catalyst **388**, the propargylamine **385** was obtained with excellent ee but poor dr. On the

other hand, when **383** was reacted with the β -keto-ester **386** in the presence of catalyst **389**, both excellent ee and dr were observed (Scheme 85).²⁶¹

Scheme 85. Synthesis of propargylamines using Brønsted base organocatalysts

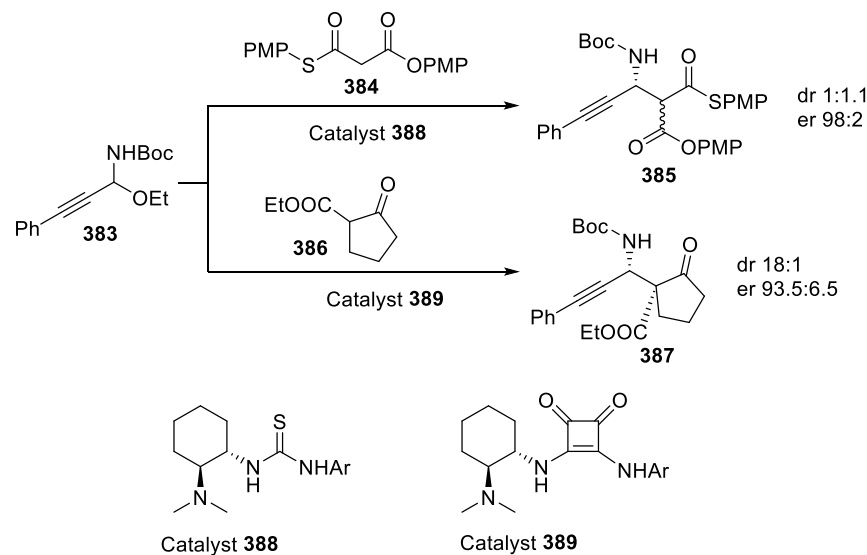

The authors hypothesized that a mild non-covalent hydrogen bond could simply promote the cleavage of the C–O bond of *N,O*-acetals **383** and also stabilize the resulting *N*-Boc-*C*-alkynyl imines, as shown in Scheme 86. The *in situ* formed alkynyl imine **390** then reacts with the malonate thioester or β -keto-ester to afford the desired propargylamine. It is likely that the Brønsted catalyst could play a role also in the activation of the ketone reagents.

Scheme 86. Mechanism of the Brønsted base organocatalyzed synthesis of propargylamines.

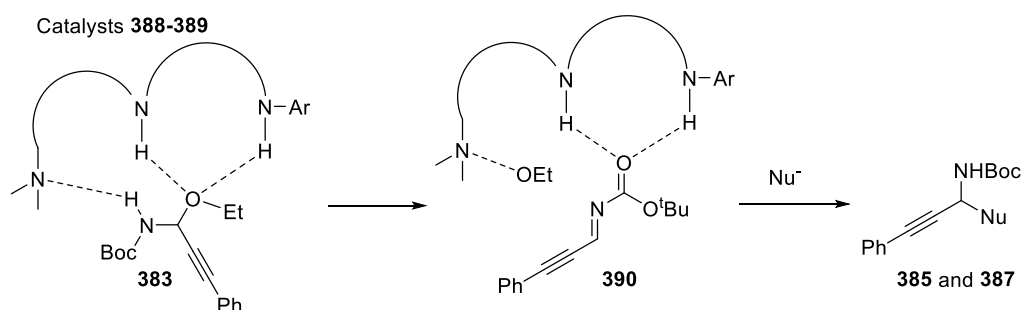

Another interesting organocatalytic approach to optically active propargylic amines consists of the kinetic resolution (KR) of the corresponding racemic amines. The first example has been reported by Seidel and co-workers, who used a dual catalytic approach involving a chiral thiourea-acylpyridinium catalyst **393** to afford enantiopure propargylamines **392** with high selectivity factor (s-factor). Scheme 87. The concept behind the KR approach relies on the formation of a chiral ion pair. A simple achiral acyl pyridinium salt (ion pair I) is first formed *in situ* from DMAP and an acylating reagent (benzoic anhydride). The binding of the associated anion X^- to a chiral thiourea compound makes the ion pair II to become chiral. The authors identified proper reaction conditions under which the primary propargylamines react predominantly with ion pair II over ion pair I or a free acylating reagent. This approach enables the KR of racemic propargylamine **391**.²⁶²

Scheme 87. Organocatalytic kinetic resolution of propargylamines.

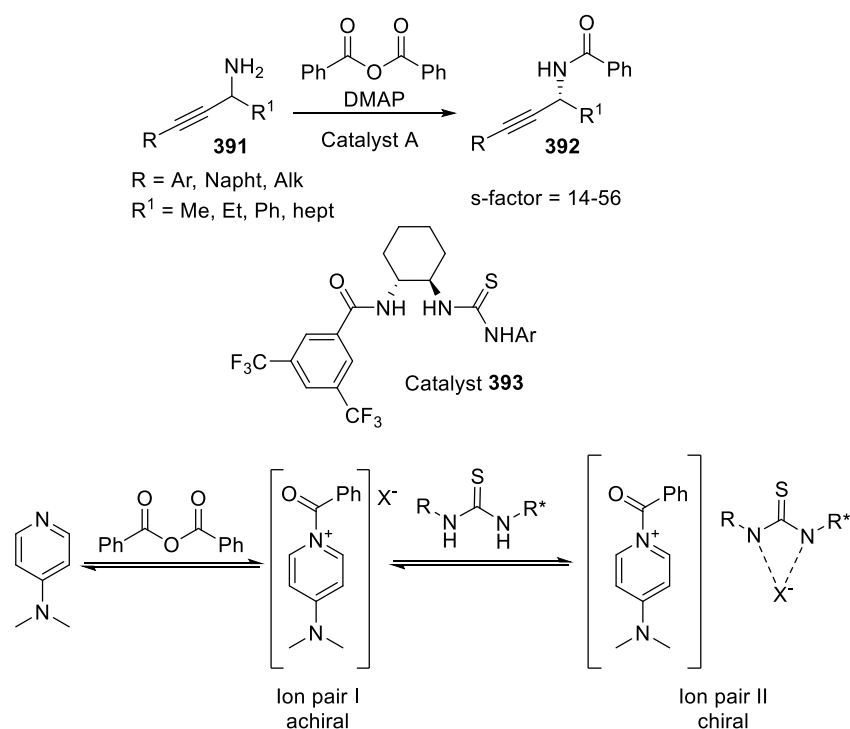

More recently Cossy and co-workers reported a similar approach to propargylamines using the chiral catalyst **394** (Scheme 88). The latter also brings an acetyl group which is transferred to the propargylamine **395** in the KR reaction.²⁶³

Scheme 88. Organocatalytic kinetic resolution using catalysts **394**.

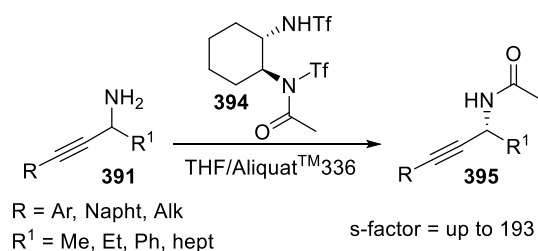

2.15 Biocatalyzed synthesis of propargylamines

Enzymatic reactions represent a green way for the synthesis of enantiomerically pure compounds, including propargylamines. The first enzymatic synthesis of enantiopure 1-aryl-propargylamines has been reported in 1999 by Messina *et al.* who described the enzymatic kinetic resolution of racemic amines **397** using *Candida antarctica lipase B* (CAL-B). A set of 1-aryl-propargylamines **397** was synthesized from the corresponding propargylic alcohols **396** *via* Ritter reaction followed by acidic hydrolysis. The racemic propargylamines were then treated with CAL-B and the enantiomers (*S*)-**397** and (*R*)-**397** were obtained with excellent ee (>88%). Table 25. Ethyl acetate was used as acetyl group donor. Interestingly, the substituents on the aryl ring influence the enzymatic resolution and the compounds bearing a substituent in ortho position on the phenyl ring were recovered with only 22% and 57% ee respectively (*entry 6*).²⁶⁴ The absolute configuration was determined by analogy with that of the corresponding 1-aryl-propylamines. The enzymatic methodology was used later by Castagnolo *et al.* to convert the enantiopure propargylamine (*R*)-**397** into the paclitaxel side chain.²⁶⁵

Table 25. Enzymatic kinetic resolution of propargylamines with CAL-B.

Entry	R	<i>(S)</i> -397		<i>(R)</i> -397	
		Yield (%)	ee (%)	Yield (%)	ee (%)
1	4-H	40	97	45	>98
2	4-Cl	40	98	43	>98
3	4-F	40	88	38	98
4	3-F	46	93	38	>98
5	3-Me	32	98	40	98
6	2-Me	ND	22	ND	57

Earlier, in 1997, Cossy *et al.* reported a semi-enzymatic approach to β -propargylamino acids, as precursors of a platelet aggregator inhibitor **402**. The β -keto ester **399** was selectively reduced to propargylic alcohol **400** (ee 94%) using Baker's yeast (Scheme 89). The alcohol was then converted into enantioenriched propargylamine **401** *via* Mitsunobu reaction with HN_3 , DEAD and PPh_3 followed by aqueous hydrolysis.²⁶⁶

Scheme 89. Enzymatic synthesis of propargylamines with Baker's yeast and PGA.

Cossy

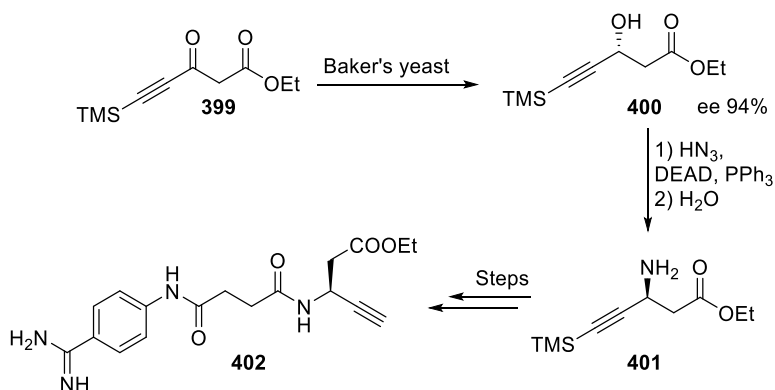

Landis

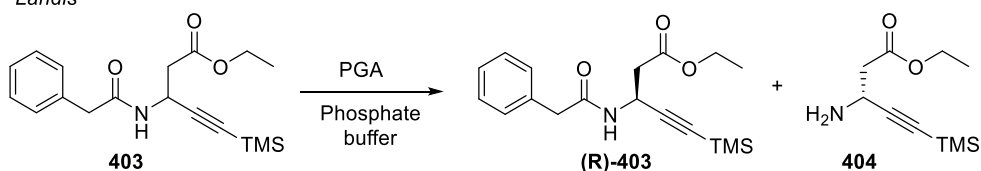

Penicillin G amidohydrolase (PGA) has been also used by Landis for the selective amidation/amide hydrolysis of the propargylamine derivatives (Scheme 89).²⁶⁷⁻²⁶⁸

A recent and interesting biocatalytic approach to propargylamines has been reported by Kroutil and co-workers. Prochiral aromatic propargyl ketones **405** were converted into propargylamines using ω -transaminases (ω -TA). Both the (*R*) and the (*S*) enantiomers were synthesized employing either (*R*)-selective ω -transaminases (ω -TAs) originating from *Arthrobacter sp.* and *Aspergillus terreus* or an (*S*)-selective ω -transaminase from *Chromobacterium violaceum* (Scheme 90). The resulting propargylamines **406** were obtained with high conversions (up to 99%) and excellent ee (>99%). Alanine was used as the source of nitrogen and alanine dehydrogenase (AlaDH) was used as recycling enzyme.²⁶⁹

Scheme 90. Synthesis of propargylamines using ω -transaminases

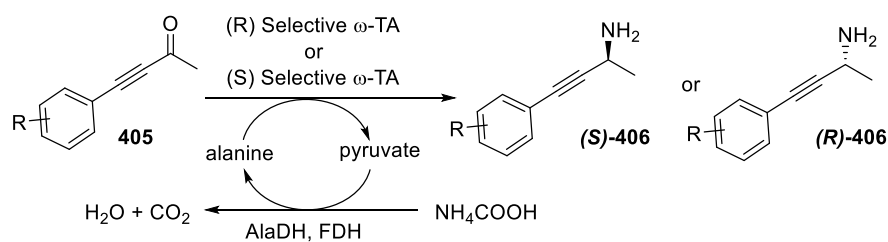

R = H, *p*-Me, *p*-MeO, *m*-MeO, *p*-Br

Finally, an interesting biocatalytic approach to propargylamines has been reported very recently by Turner and co-workers. The authors identified and developed an NADP(H)-dependent reductive aminase from *Aspergillus oryzae* (AspRedAm) able to catalyze the reductive coupling of a broad set of carbonyl compounds with a variety of primary and secondary amines. A number of propargylamines derivatives **408** were obtained with up to >98% conversion and >98% ee (Table 26).²⁷⁰ The carbonyl and the amine can in some cases be used in a 1:1 ratio leading to amine products with up to 94% conversion. The AspRedAm formally catalyzes a reductive amination reaction, allowing the formation of an imine intermediate as well as its reduction to afford **408**. Crystal structures of AspRedAm in complex with NADP(H) and also with both NADP(H) and the pharmaceutical ingredient (*R*)-rasagiline were reported.

Table 26. Synthesis of propargylamines using AspRedAm

Entry	Propargylamine 408	Conv. (%)	ee (%)
1		94	-

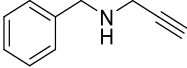
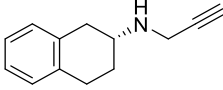
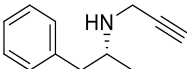
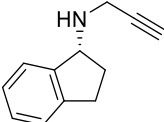
2		92	-
3		45	97
4		>97	>98
5		64	95

3. REACTIVITY OF PROPARGYLAMINES

Propargylamines have been used as versatile building blocks for the manufacturing of a wide range of different aromatic nitrogen heterocycles due to their unique chemical structure which consists of a nucleophilic amine and an acetylene moiety on the same backbone. This unique characteristic allows the propargylamine compounds to act both as electrophilic and nucleophilic substrate in chemical transformations. There are various approaches to synthesize heterocyclic organic compounds from propargylamines and are generally catalyzed by transition metal catalysts such Au, Cu, and Pd. In addition, metal-free methods to synthesize heterocycles from propargylamines have been also described. In this section, an overview of the reactions and chemical processes available to convert propargylamine substrates into heterocyclic compounds and other useful synthetic scaffolds is shown.

3.1 Synthesis of pyrroles from *N*-propargylamines

Pyrroles represent an important class of aromatic compounds which find broad application in pharmaceutical chemistry and constitute the core of many natural compounds. Several

methods for the synthesis of pyrroles from propargylamines have been reported in the literature.

3.1.1 Metal-catalyzed synthesis of pyrroles. Palladium catalysts have a great affinity for triple bonds and thus can be exploited for the activation and conversion of propargylamines into interesting heterocycles, including pyrroles. In 1996, Gleiter and Ritter described an efficient Pd-catalyzed synthesis of *N,N'*-dialkyl-3,3'-bispyrroles **410** from cyclic *N*-propargylamine **409**. The substrate **409** was treated with Pd/C 5 mol% in methanol at 140 °C leading to the formation of **410** as the main reaction product. The authors hypothesized that the Pd catalyst can coordinate to both of the triple bonds with the support of the nitrogen lone pair as shown in Scheme 91. The complex should then favor the formation of the metallocyclic intermediate **412** which in turn yields the final product **410**.²⁷¹

Scheme 91. Synthesis of bispyrrole 410.

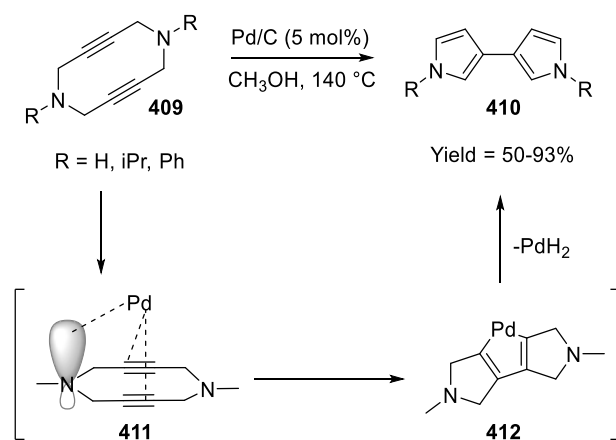

Muller and co-workers later proposed an interesting one-pot synthesis of 2,4-substituted pyrroles. The authors developed a Pd/Cu-catalyzed one-pot three-component reaction for the synthesis of 2-substituted *N*-Boc-4-iodopyrroles **416** from *N*-Boc-protected propargylamine **413** through reaction with an acid chloride **414** followed by a cyclization in the presence of NaI and PTSA. Scheme 92. First, a Sonogashira cross-coupling reaction of **413** and **414** in

the presence of PdCl₂(PPh)₃ and CuI occurs, leading to the formation of an alkynone intermediate **415**. This is in turn converted in good yields to the 2-substituted *N*-Boc-4-iodopyrroles **416** through reaction with NaI in the presence of *p*-toluenesulfonic acid (PTSA). Finally, pyrrole **416** was converted to 4-alkynyl-*N*-Boc-pyrroles **417** *in situ* by addition of a terminal alkyne to the reaction mixture in the presence of Cs₂CO₃.²⁷²

Scheme 92. Pd/Cu catalyzed synthesis of pyrroles 416 and 417.

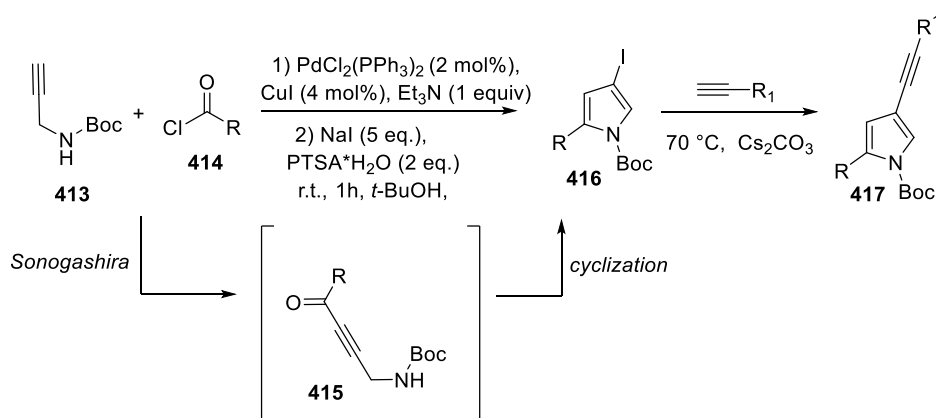

The synthesis of 1,4,5-trisubstituted pyrroles from propargylamines and bromobenzenes *via* a Pd(II)-catalyzed coupling/cycloisomerization reaction was described by Meng *et al.* in 2009. Bromobenzenes **418** were reacted with propargylamine **419** at 140 °C in DMF in the presence of Pd(OAc)₂/PPh₃ and (*n*-Bu)₃N as base, which led to the formation of pyrroles **420** in good yields.²⁷³ The reaction outcome is strictly related to the electronic character of the aryl halides. Bromobenzenes bearing electron-donating substituents in *meta* and *para* positions afforded the corresponding pyrroles in good to high yields, whilst the presence of electron-withdrawing substituents on the aryl moiety was not tolerated. It is noteworthy that when the phenyl substituent of **419** was replaced with a methyl group, as in **421**, the formation of the pyrroline derivative **422** rather than the pyrrole was observed. (Scheme 93).

Scheme 93. Pd(II)-catalyzed coupling/cycloisomerization reaction of propargylamines with bromobenzenes.

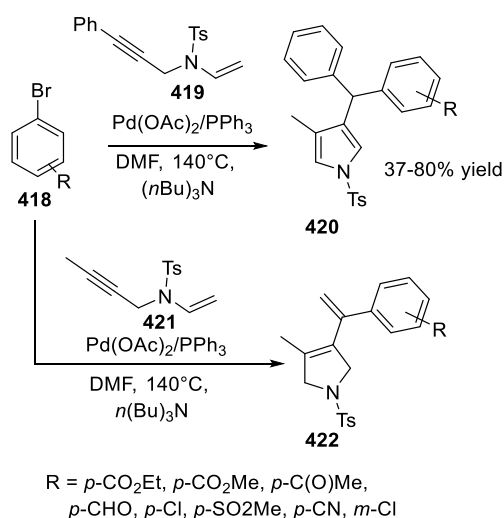

In 2011, Trost *et al.* reported the synthesis of 2,4-disubstituted pyrroles **425** through a cascade reaction of a propargylamine derivative **423** with an array of alkynes **424** catalyzed by Pd(OAc)₂ (Table 27).²⁷⁴ The reaction proceeds through the addition of alkyne **424** to **423** followed by a 5-*endo-dig*-cyclization and tautomerization of the yneone intermediate into the desired pyrrole **425**. Interestingly, the electronic character of the substituents of **424** had no effect on the outcome of the reaction, allowing for all of the substrates to be converted efficiently to the corresponding pyrroles under optimized condition.

Table 27. Pd-catalyzed cascade reaction of propargylamines and alkynes

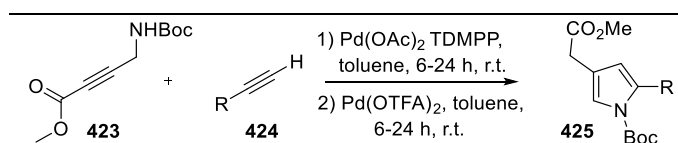

Entry	R	Yield (%)
1	Ph	80
2	<i>p</i> - <i>n</i> -Bu-Ph	97
3	<i>m</i> -F-Ph	89

4	<i>m</i> -Br-Ph	75
5	<i>p</i> -Br-Ph	86
6	<i>p</i> -CHO-Ph	90
7	<i>p</i> -CH ₃ O-Ph	81
8	<i>m</i> -CH ₃ O-Ph	99
9	<i>m</i> -NH ₂ -Ph	82
10	1-Cyclohexene	96
11	<i>n</i> -Bu	97
12	<i>t</i> -Bu	60
13	<i>i</i> -Pr-OH	70
14	CH ₂ OAc	74
15	CHPhOH	70
16	BDMS	68

In addition to palladium, copper catalysts have also been used for the synthesis of pyrroles from propargylamines. Sakai and co-workers described the copper-catalyzed synthesis of 1,2,5-substituted pyrroles **428** through the reaction of *N*-propargylamines **426** with *N,O*-acetyls **427** in the presence of CuCl₂. The reaction was found to be versatile; the desired pyrroles were afforded through a [4+1]-annulation mechanism. The copper catalyst activates the *N,O*-acetal **427** to yield the iminium intermediate **429**. Then, the nitrogen atom on propargylamine **426** attacks the iminium leading to the formation of the *N,N*-aminal intermediate **430**. This latter then reacts with the copper catalyst to generate the copper enolate intermediate **431**. Finally, intramolecular *5-endo-dig* cyclization followed by aromatization led to the pyrrole **428**. Both primary and secondary propargylamines were used

as substrates as well as a variety of *N,O*-acetals bearing an enolizable substituent adjacent to the central sp^3 -carbon (Scheme 94).²⁷⁵

Scheme 94. Copper catalyzed synthesis of pyrroles from propargylamines 426.

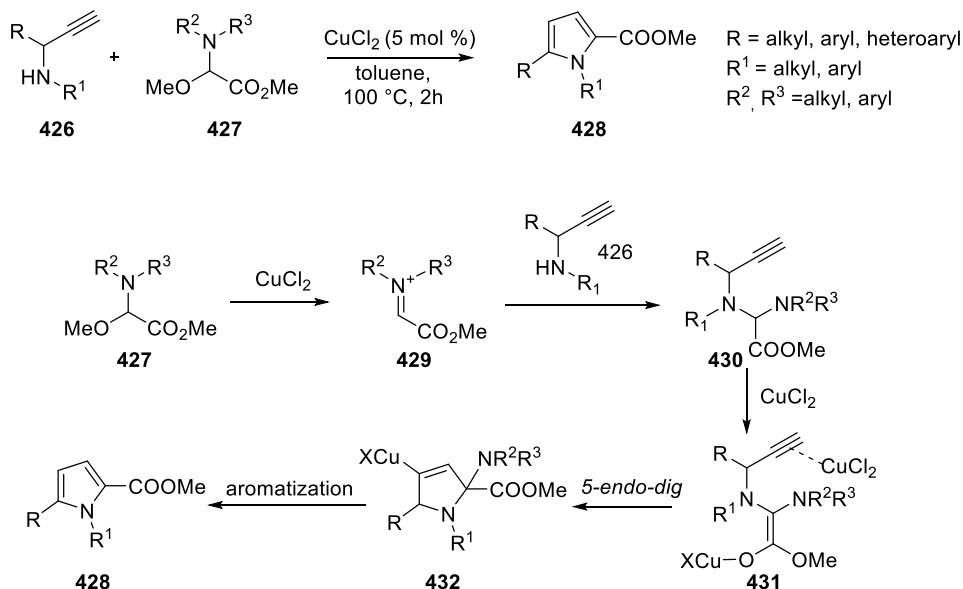

Wang and co-workers described a two-step approach to pyrroles from *N*-protected-*N*-vinyl-propargylamines **433** through a Cu(II)-mediated electrophilic cyclization reaction. Treatment of **433** with CuCl_2 at room temperature led to the formation of the 3-pyrrolines **434**, which were in turn easily converted into the corresponding tri-substituted pyrroles **435** by treatment with NaCl (Scheme 95).²⁷⁶

Scheme 95. Cu(II)-catalyzed synthesis of pyrroles

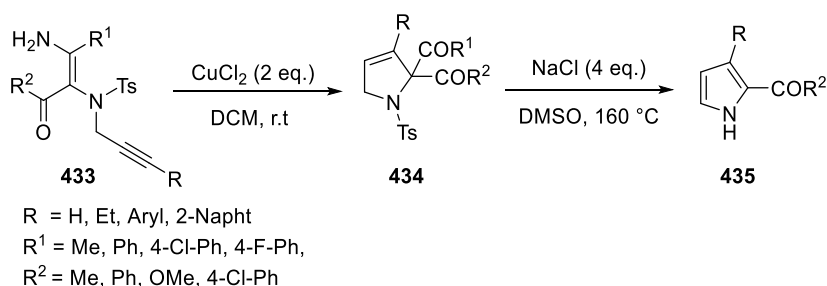

Other metal catalysts have been also used to convert propargylamines into pyrroles. In 2009, Zhao and co-workers reported the synthesis of pyrroles **437** from substituted *N*-

propargylamines **436** *via* an Au(III)-catalyzed hydroamination (*5-endo-dig* cyclization) reaction. The reaction afforded *N*-substituted pyrroles decorated at C-2 position with an aminomethyl group in good yields. (Scheme 96).²⁷⁷

Later, Saito *et al.* investigated the possibility of obtaining pyrroles **440** *via* an Au-catalyzed amino-Claisen rearrangement of *N*-propargylamine derivatives. Polysubstituted pyrroles **440** bearing an ester moiety at C-3 position were efficiently obtained from *N*-vinylpropargylamines **438** when treated with [(IPr)Au(MeCN)]BF₄ as a catalyst at room temperature. The reaction proceeds through an amino-Claisen rearrangement as shown in Scheme 96.²⁷⁸

An interesting iridium catalysed approach to polycyclic pyrrole **445** was described earlier by Yamamoto and co-workers. The authors synthesized a series of *N*-allyl-propargylamines **441** *via* a standard A³ coupling reaction using CuBr₂ as catalyst. Amines **441** were then treated with [IrCl(cod)₂] catalyst to yield dienes **442** *via* a cycloisomerization reaction. A subsequent Diels–Alder reaction with the dienophile **443** followed by dehydrogenative aromatization led to desired pyrrole (Scheme 96).²⁷⁹

Scheme 96. Au- and Ir-catalyzed synthesis of pyrroles from propargylamines.

Zhao

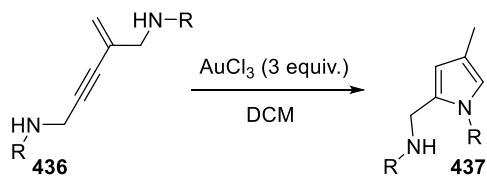

R = alkyl, aryl, Ts, Boc, Cbz, Bz

Saito

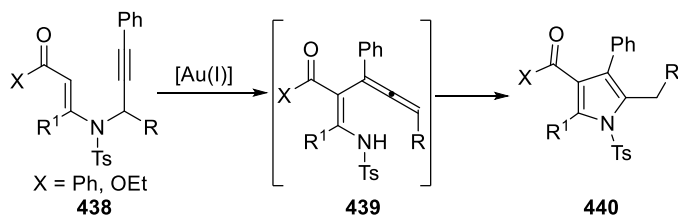

Yamamoto

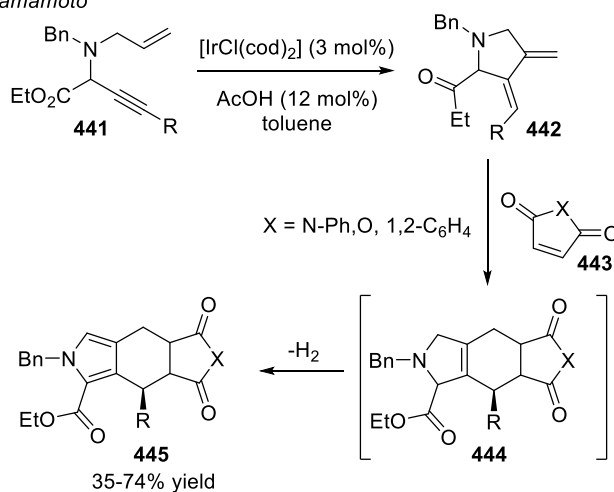

A rhodium catalyzed hydroformylation-cyclization reaction leading to aryl-pyrroles from propargylamines was described by Campi *et al.* in which propargylamines were treated with $[\text{Rh}(\text{OAc})_2]_2/\text{PPh}_3$ catalyst under CO/H_2 atmosphere, affording the desired aryl-pyrroles in good yields.²⁸⁰

Enyne metathesis, namely the reaction between an alkyne and an alkene catalyzed by ruthenium catalysts, has become a popular method for the synthesis of many heterocyclic compounds, both in its intramolecular (ring-closing enyne metathesis – RCEYM) and intermolecular (enyne cross-metathesis – EYCM) form. Relatively few methods have been developed recently to access pyrroles from propargylamine substrates *via* enyne metathesis

reactions. Stevens and co-workers first reported the synthesis of 2-phosphono pyrroles **449** *via* a one pot intramolecular RCEYM. The *N*-allyl-propargylamine **446** was treated with Grubbs' catalyst 2nd generation **GII**, in the presence of TCQ which behaves as an oxidizing agent, to afford pyrrole **449** in a single step (Scheme 97). **GII** promotes the metathesis step to lead to a pyrroline intermediate which is in turn oxidized into the pyrrole by TCQ.²⁸¹

Scheme 97. RCEYM approach to pyrroles from propargylamines

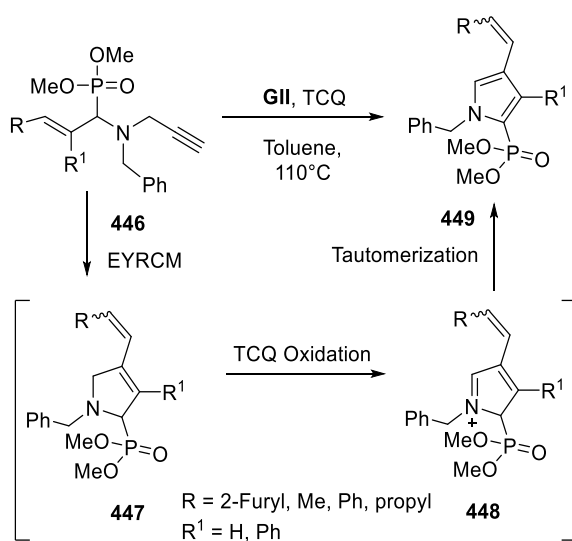

More recently, our research group developed a EYCM approach for the direct synthesis of 1,2,3-substituted pyrroles **452** from propargylamines.²⁸² A set of propargylamines **450** was reacted under microwave irradiation with EVE in the presence of **GII** and CuSO₄ to afford a wide range of substituted pyrroles **452** in minutes. The EVE is supposed to act as a synthetic equivalent of acetaldehyde as previously reported by us.²⁸³ The reaction is supposed to occur through the formation of the EYCM diene product **451** first. Then, the coordination of the CuSO₄ to the ethoxy moiety can favor the collapsing of the nitrogen atom on the enol carbon and promote the cyclization step. The presence of the CuSO₄ proved to be crucial for the reaction. In fact, when the reaction was carried out without any copper additive, only the diene **451** was obtained. The replacement of CuSO₄ with other copper salts such as CuBr₂, CuI or Cu(OTf)₂, resulted in lower or comparable yields. The method proved to be a versatile

means of synthesizing a variety of pyrroles **452** substituted on C-2 with both aromatic and aliphatic groups as well as bearing a variety of aromatic and EWG-substituents on the nitrogen (Table 28).

Table 28. EYCM synthesis of pyrroles from propargylamines.

Entry	R	R ¹	Yield (%)
1	Ph	Ac	70
2	4-Cl-Ph	Ac	72
3	3-F-Ph	Ac	76
4	2,4-Cl-Ph	Ac	38
5	4-Ph-Ph	Ac	59
6	Ph	Ts	38
7	4-Cl-Ph	Boc	50
8	4-Cl-Ph	Bz	64
9	Ph	Ph	Traces
10	2-Furyl	Ts	76
11	Cyclohexyl	Ts	43
12	<i>i</i> -Pr	Ts	71
13	<i>i</i> -Bu	Ts	69

3.1.2 Miscellaneous metal free synthesis of pyrroles. Several authors described the synthesis of pyrroles from propargylamines using metal-free approaches such as cycloaddition reactions, aza-Claisen rearrangements and base-promoted cyclizations.

In 1994, Lee and co-workers reported the synthesis of bicyclic pyrrole **455** from Boc-protected furfuryl propargylamine **453**. When treated with ^tBuOK, propargylamine **453** undergoes a spontaneous intramolecular Diels–Alder reaction leading to the intermediate **454** which affords the bicyclic pyrrole **64** in 63% yield *via* an *in situ* ring opening reaction catalyzed by the base itself (Scheme 98).²⁸⁴

Scheme 98. Synthesis of bicyclic pyrroles from propargylamine 453.

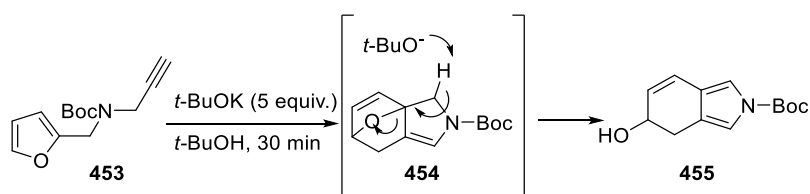

An interesting approach for the synthesis of pyrroles **458** *via* thermal rearrangement of *N*-vinyl-propargylamines **456** was described by Cossy in 1996. Various annulated[*b*]pyrroles **458** were obtained in moderate to good yields *via* a tandem aza-Claisen rearrangement–cyclization reaction as shown in Scheme 99.²⁸⁵

Bremner and Organ later reported a combinatorial approach for the synthesis of pyrroles **463** through the reaction of *N*-propargylamines **459** with aldehydes **460** in DMF at 200 °C under microwave irradiation. The reaction afforded substituted pyrroles bearing alkyl, aryl, and heteroaryl groups on the ring in high yields. The proposed mechanism of the reaction involves a condensation reaction first leading to enynamine **461**. The latter is in turn converted into imino allene intermediate **462** *via* a [3,3]-pericyclic rearrangement. Finally, cyclization of **462** led to pyrrole **463** (Scheme 99).²⁸⁶

A similar approach has been recently reported by Cacchi *et al.* who described the synthesis of 2,3,4-trisubstituted pyrroles **465** from *N*-vinylpropargylamines **464** *via* an intramolecular cyclization–protonation–isomerization cascade. The reaction is promoted simply by Cs_2CO_3 at room temperature and led to pyrroles **465** in good yields (Scheme 99).²⁸⁷

Scheme 99. Metal-free syntheses of pyrroles from propargylamines.

Cossy

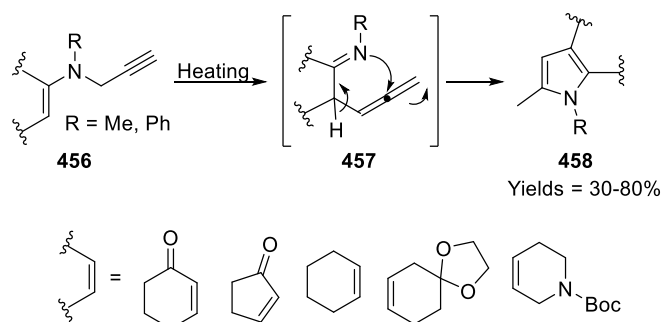

Bremner and Organ

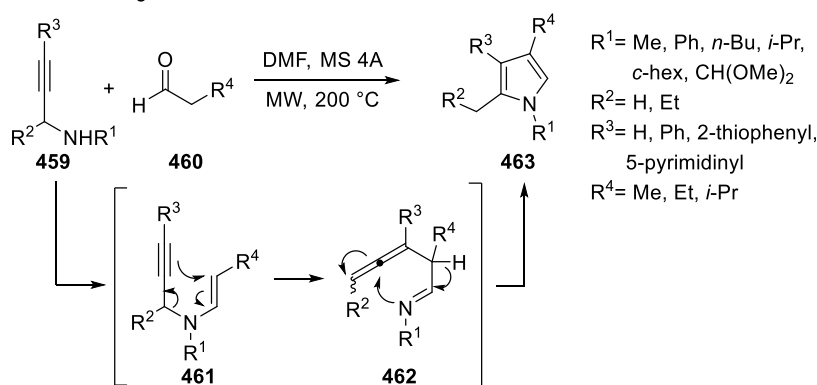

Cacchi

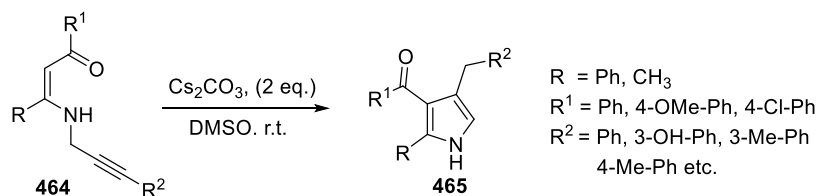

An interesting approach for the synthesis of 2,3,4-substituted pyrroles from propargylamines through a base catalyzed [2+3]-cycloaddition reaction has been reported in 2012 by Zhao and co-workers. The authors reacted a series of *N*-propargylamines **466** with α -acylketene dithioacetals **467** in DMF and pyrroles **468** were obtained in high-excellent yields (Scheme 100).²⁸⁸ The proposed mechanism of the reaction involves a 1,4-Michael addition between **466** and **467** leading first to the intermediate **469** which is in equilibrium with **470**. In presence of a base, the imine **470** undergoes intramolecular *5-exo-dig* cyclization affording

the intermediate **471** which is converted into the desired pyrroles **468** via a deacetylation and aromatization sequence.

Scheme 100. Synthesis of pyrroles via base catalyzed [2+3]-cycloaddition.

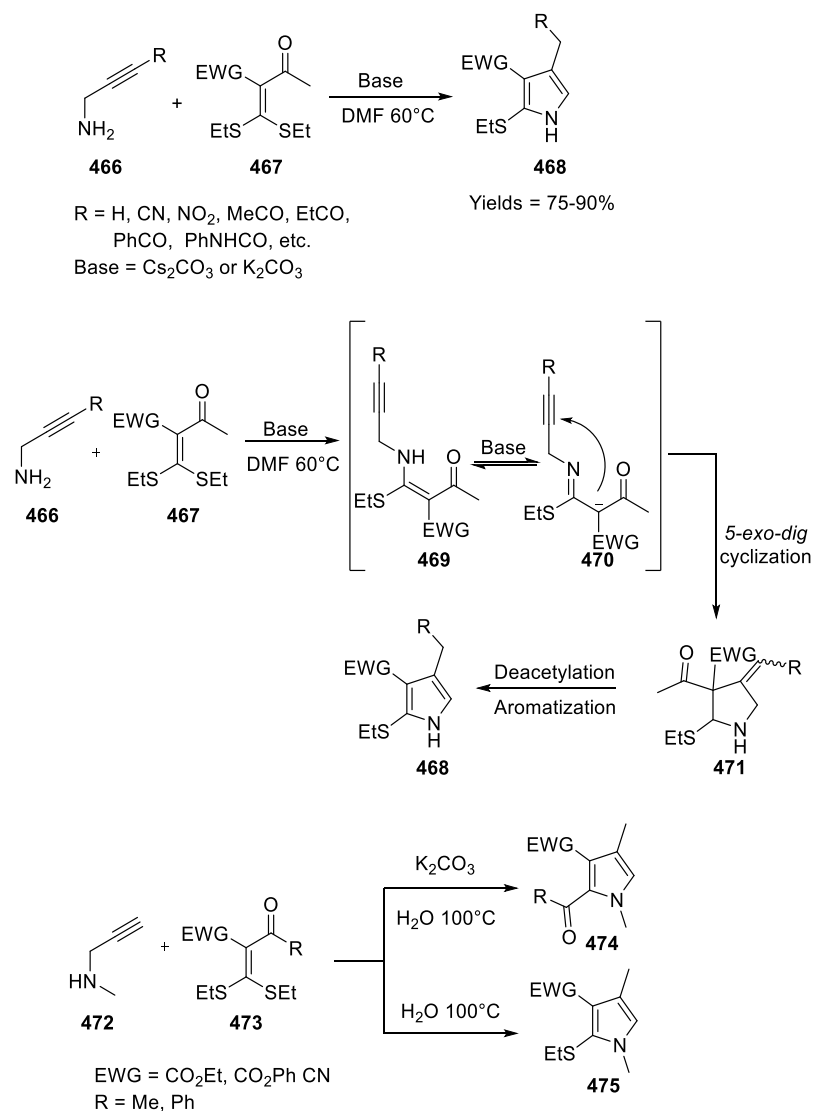

The same authors later expanded the scope of this methodology toward the synthesis of 1,2,3,4-tetrasubstituted pyrroles **474** and **475**. It is noteworthy that the presence of a base affects the outcome of the reaction. When the reaction was performed in the presence of K₂CO₃, pyrroles **474** bearing a carbonyl group in position C2 were selectively formed, whilst in absence of a base the formation of 2-EtS-pyrroles **475** was favored (Scheme 100).²⁸⁹

Another efficient synthesis of 1,2,3,5-tetrasubstituted pyrroles **478** has been described by Wan and co-workers in 2013. Imines **476** were treated with *N*-propargylamines **477** in presence of LiHMDS as base and PMDTA as the additive in THF affording pyrroles **478** in good yields (Scheme 101). In this case, the nitrogen of the pyrrole **478** comes from the imine **476**, whilst the nitrogen of the propargylamine acts as a leaving group to allow the aromatization of the pyrrole.²⁹⁰

Recently, Jin and co-workers reported an efficient protocol for the synthesis of polysubstituted (tri-, tetra-, and penta-substituted) pyrroles **481** through the reaction of alkynes **479** with primary and secondary *N*-propargylamines **480** in the presence of K₃PO₄ as catalyst. The reaction was carried out in DMSO and led to the desired pyrrole *via* a Michael addition/aza-Claisen rearrangement/cyclization sequential process (Scheme 101).²⁹¹

Scheme 101. Synthesis of pyrroles **478** and **481**.

Wan

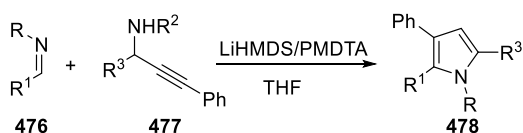

R = Ph, 2-Me-Ph

R¹ = Ph, 2-OMe-Ph, 2-Me-Ph, 2-Br-Ph, 4-Me-Ph, 4-CF₃-Ph, 2-naphthyl

R³ = Ph, 2-Me-Ph, 4-Me-Ph, 2-furyl

Jin

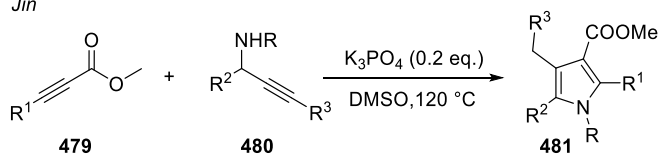

R = Bn, *n*-Pr, *i*-Pr, *n*-Bu, *i*-Bu, *s*-Bu, *t*-Bu, cyclopentyl, cyclohexyl, *n*-octyl

R¹ = H, me, COOMe

R² = H, Me, Et, Ph, *n*-Pr

R³ = H, Ph, Bn

Finally, Meng *et al.* reported an interesting approach for the synthesis of pyrroles **483** through a base-catalyzed intramolecular cyclization reaction of *N*-cyanopropargylamines **482**. The authors showed that *N*-cyanopropargylamine **482** in the presence of NaH and DMF at 130 °C underwent a cyclization–decyanation–aromatization cascade reaction leading to the

corresponding pyrroles **483** in good yields. It is noteworthy that pyrrole **483** is obtained as the only product when the reaction is carried out at 130 °C whilst at 110 °C the 2-cyano substituted pyrrole **484** is formed as the major compound in 70% yield. (Scheme 102). The scope of the reaction is limited to internal alkynes only. The corresponding terminal alkynes **485** afforded the corresponding 2-pyrrolines **486** when treated under the same reaction conditions.²⁹²

Scheme 102. Cyclization of *N*-cyanopropargylamines.

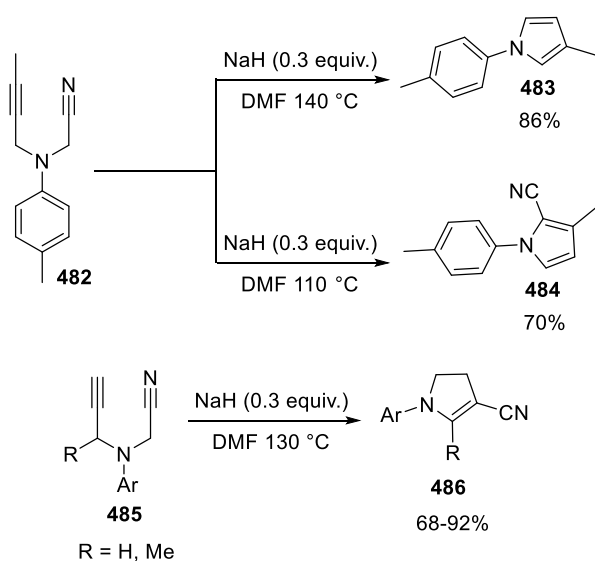

3.2 Synthesis of pyrrolines from propargylamines

Pyrrolines, and in particular 3-pyrrolines, are an important class of compound which found extensive use in medicinal chemistry as starting materials and intermediates in the synthesis of various natural products including pyrrole derivatives. An early method to synthesize 3-pyrrolines from *N*-aryl-propargylamines **487** has been reported in 1999 by Balasubramanian and co-workers *via* a formylation-cyclization reaction using CuI as catalyst. *N*-Propargylanilines **487** were reacted with formaldehyde and DIPA in the presence of CuI to give 3-pyrrolines **488** in good yields (Scheme 103).²⁹³ The authors hypothesized two possible reaction mechanisms. In both cases an allene intermediate **490** is formed. The allene can a)

undergo an 1,3-homosigmatropic shift leading to aziridine **491** and then to 3-pyrroline **488**, or alternatively b) cyclize after complexation with Cu(I). Interestingly, when the same reaction was carried out in ethylene glycol at reflux, the corresponding pyrrole derivatives were obtained.

Scheme 103. Copper catalyzed synthesis of 3-pyrrolines.

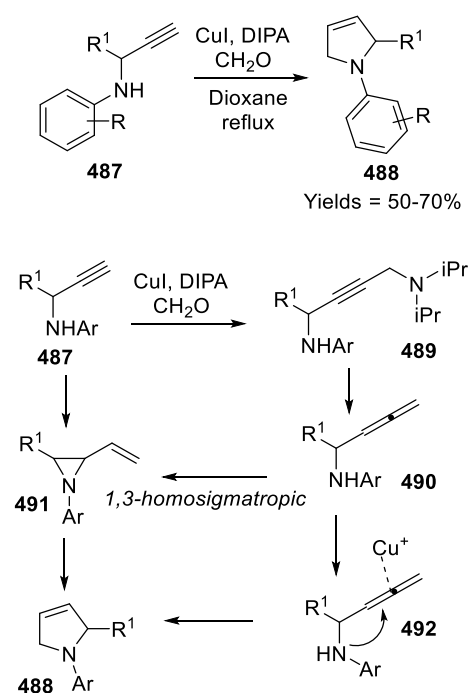

3.2.1 Enyne metathesis reactions. Enyne metathesis reactions represent probably the most widely used approach to synthesize 3-pyrrolines from *N*-allyl-propargylamines.²⁹⁴ In particular, the intramolecular variant of the enyne metathesis is a popular method to synthesize 3-pyrrolines from propargylamines. Different Ru-carbene catalysts (Grubbs' 1st **GI**, 2nd **GII** and 3rd **GIII** generation catalysts, Hoveyda **HG** and Blechert **BG** catalysts) have been used to promote the enyne metathesis reactions.

The first example of enyne metathesis applied to the synthesis of nitrogen heterocycles was reported by Mori *et al.* who described the synthesis of a series of 3-pyrrolines **494** from propargylamine substrates **493** using 1 mol% **GII** (Scheme 104).²⁹⁵

Interestingly, the terminal propargylamine **493** (R = H) led to **494a** in poor yield whilst higher conversion was observed for amine **494b** (R = Me), which bears an internal triple bond. It was hypothesized that the terminal alkene of **494a** could further react with the Ru-catalyst leading to the intermediate **495** where the Ru is stabilized by the pyrroline double bond. The interaction between the substrate and the catalyst decreases the catalytic activity and accounts for the low yields observed. The presence of a methyl substituent on the double bond of the diene **494b** makes it less reactive toward additional side metathesis reactions, mainly due to steric factors. To overcome this issue, the same reaction was carried out under ethylene gas, which resulted in a dramatic increase of the yield of **494a** to 90%. This phenomenon is due to the continuous reaction of the ethylene gas with the Ru-intermediate **495** allowing, *via* alkene cross metathesis, the regeneration of the substrate **494a** *via* olefin cross metathesis.²⁹⁶

Scheme 104. Mori's approach to 3-pyrrolines from **493**.

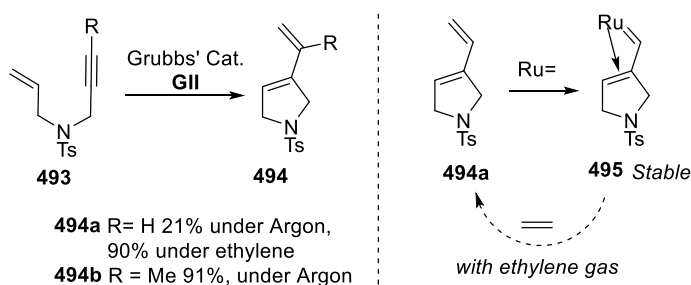

Following the pioneering work of Mori, other authors reported the synthesis of a variety of 3-pyrroline compounds from *N*-allyl-propargylamines *via* RCEYM reactions. Yiang *et al.* described the synthesis of a series of pyrrolines **497** *via* RCEYM using 5 mol% of **GI**,²⁹⁷ whilst Nolan and co-workers reported the use of a series of phosphabicyclononane (Phoban)-containing ruthenium-based catalysts **500** and **501** (Scheme 105) for the synthesis of 3-pyrrolines **499**.²⁹⁸

Scheme 105. RCEYM using GI and Phoban-Ru catalysts.

Yiang et al.

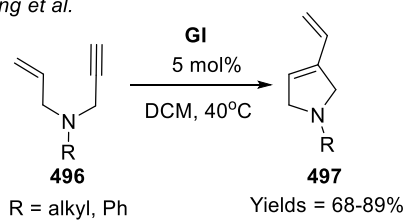

Nolan and co-workers

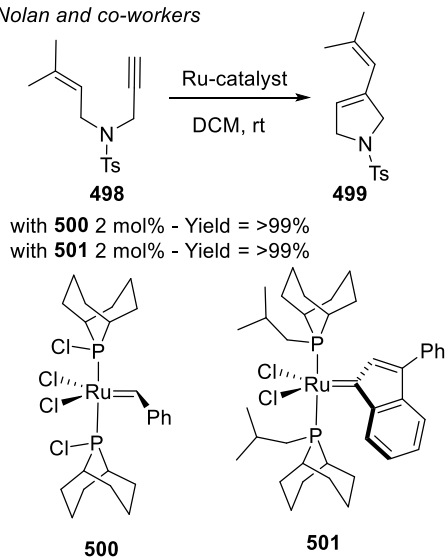

In 2010, Zhu and Shi reported an elegant metathesis cascade reaction to access polysubstituted 3-pyrroline substrates **503**.²⁹⁹ The reaction exploits a series of sequential metathesis reactions as shown in Scheme 106. The 1,6-cyclopropene-yne **502** reacts with GI catalysts to yield the intermediate **506** through an enyne RCM, which in turn reacts with an external alkene in a cross-metathesis reaction leading to the final pyrroline **504**. Several compounds have been synthesized by this method in variable yields (35-78%).

Scheme 106. Metathesis cascade reaction of propargylamine 502.

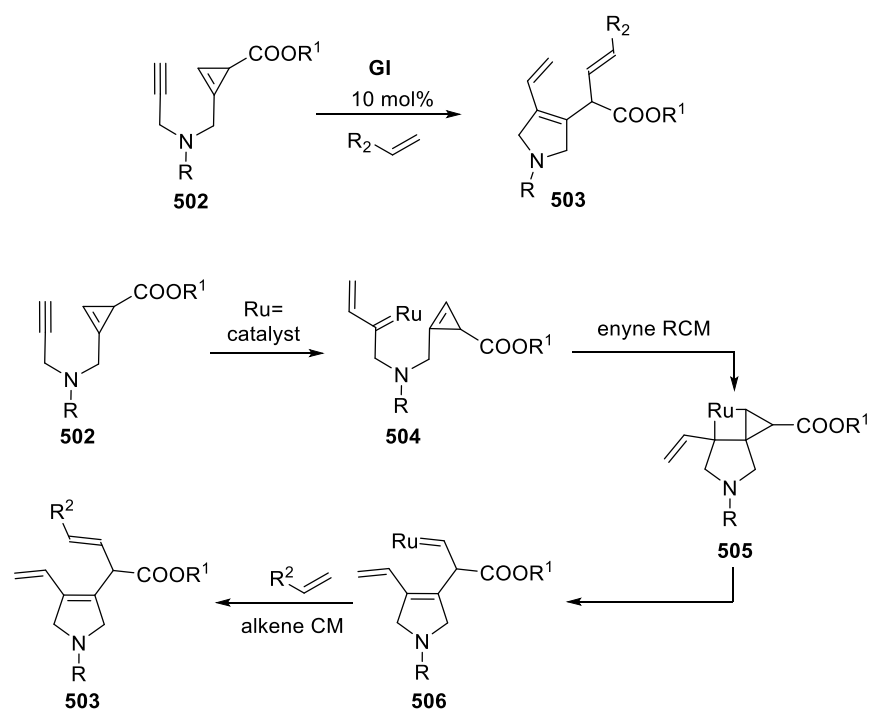

Finally, Snapper and co-workers reported a series of tandem enyne metathesis/hydrovinylation reactions on a variety of enyne substrates, yielding, amongst others, pyrroline derivatives.³⁰⁰

The intermolecular variant of the enyne metathesis is the EYCM of an alkyne with an alkene in the presence of a Ru-carbene which leads to the formation of a 1,3-diene product. Comparably few examples of the synthesis of 3-pyrroline compounds *via* enyne cross-metathesis have been developed. Mori and co-workers described an elegant approach to synthesise the 3-pyrroline **510** through a metathesis cascade from the propargylamine **507**.³⁰¹ Compound **507** undergoes EYCM with ethylene leading to the Ru-carbene intermediate **508**. This further reacts with the double bond of the cyclohexene moiety leading, through a ring-opening metathesis (ROM) reaction, to the final pyrroline **510** (Scheme 107).

Scheme 107. EYCM approaches to 3-pyrrolines.

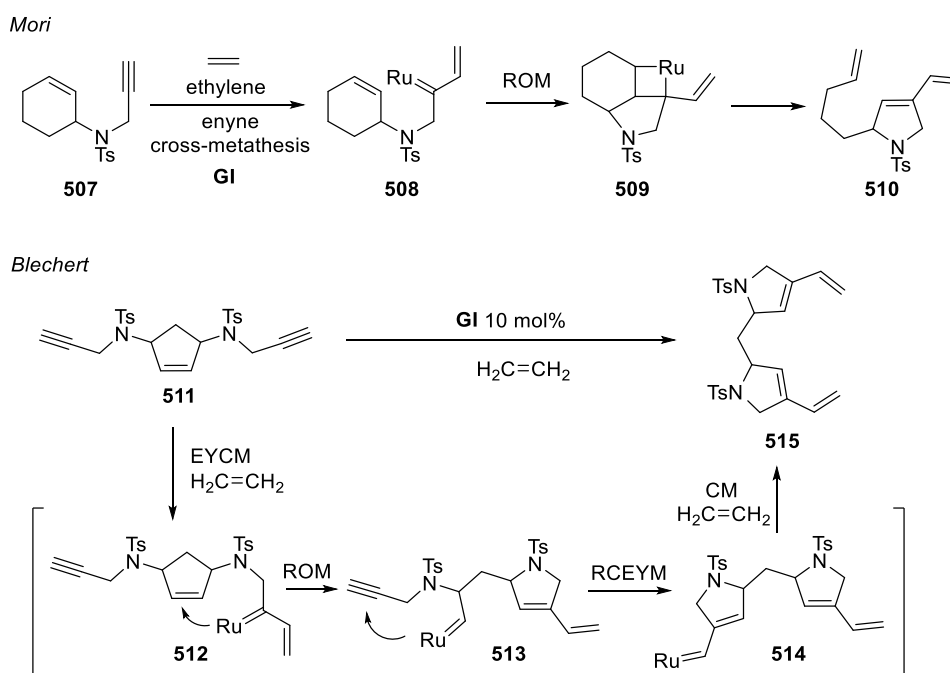

An elegant approach for the synthesis of pyrroline **515** from bis-propargylamine **511** through a cascade metathesis sequence was reported by Blechert and co-workers in 2002.³⁰² The reaction of **511** with ethylene leads in the first instance to the formation of the Ru-carbene intermediate **512**. This latter undergoes a ring-opening metathesis (ROM) on the cyclopentene ring, allowing for the formation of the first pyrroline nucleus. The formed carbene **513** then reacts with the terminal alkyne to afford the intermediate **514** which finally reacts with ethylene gas leading to product **515** (Scheme 107).

3.2.2 Other approaches to pyrrolines. Other methods to synthesize pyrrolines have been recently described. In 2012 Polindara-García and Miranda reported an interesting approach to synthesize 2-pyrrolines **517** from propargylamine **516** by treatment with ^tBuOK in THF at room temperature. The propargylamine **516** was obtained *via* an indium catalyzed Ugi four-component reaction with commercial propargylamine (Scheme 108).³⁰³

Kang and co-workers developed the synthesis of 3-pyrroline derivatives through a copper-catalyzed domino homology and cycloisomerization reaction of propargylamines **518**.

Treatment of **518** with formaldehyde, CuBr and cyclohexylamine under microwave irradiation at 180 °C led to a series of pyrrolines **519** in variable yields (19-95%).³⁰⁴ The reaction is supposed to proceed through the copper mediated homologation of the alkyne group with the iminium intermediate **520** and formation of the allene intermediate **522**. Cu(I)-catalyzed *5-endo* cycloisomerization of **522** and subsequent demetalation leads to the pyrroline product **519** (Scheme 108).

Scheme 108. Synthesis of 2- and 3-pyrrolines 517 and 519.

Polindara-Garcia and Miranda

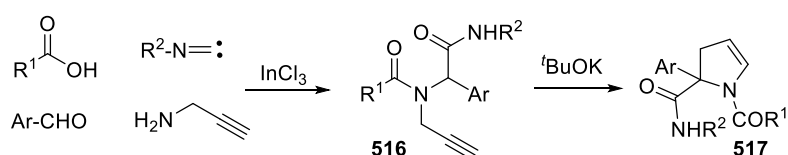

Kang

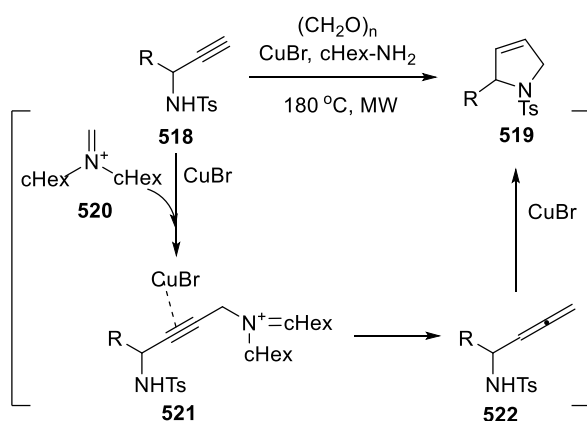

Wang and co-workers described an interesting synthesis of propargylamine derivative **525** *via* iodine(III)-mediated oxidative cross-coupling of the enamine **524** with propargylamine **523**. Derivative **525** was then promptly cyclized into pyrrolines **526** through electrophilic cyclization using different Cu(II) catalysts (Scheme 109).²⁷⁶

Yamada and co-workers reported an elegant approach to pyrrolinones **528** *via* a silver-catalyzed CO_2 incorporation reaction into propargylamine **527** followed by intramolecular rearrangement.³⁰⁵ A number of pyrrolinones **528** were synthesized in excellent yields and the method was used by the authors for the synthesis of tetramic acid derivatives (Scheme 109).

Scheme 109. Synthesis of 3-pyrrolines 526 and pyrrolinones 528.

Zheng

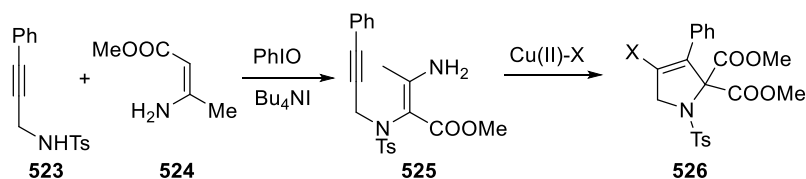

Yamada

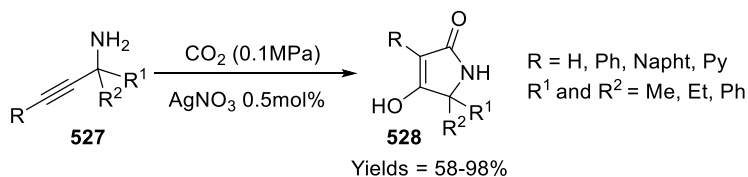

Finally, it is worth mentioning the work of Kanurakar and co-workers who reported a gold(I) catalyzed reaction of propargylamine derivatives with arynes to synthesize 3-methylene-1-pyrrolines.³⁰⁶

3.3 Synthesis of pyrrolidines from propargylamines

A number of approaches to synthesize pyrrolidine derivatives from propargylamines have been described in the literature. In 1999, Balme and co-workers described an efficient approach for the synthesis of highly substituted pyrrolidine derivatives through a tandem reaction of lithiated *N*-substituted propargylamine 529 with various Michael acceptors 530 in the presence of CuI (3 mol%) and *n*-BuLi in THF at room temperature.³⁰⁷ According to the proposed mechanism, the propargylamine nitrogen is activated by BuLi allowing the addition of the lithiated amine to the malonate. Then a copper-promoted cycloisomerization leads to the formation of the desired product 531. As shown in Table 29 the Cu-catalyzed reaction affords the corresponding pyrrolidines in good yields.

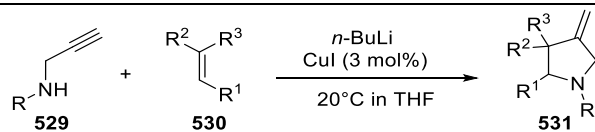
Table 29. Synthesis of pyrrolidines 531.

Entry	R	R ¹	R ²	R ³	Yield (%)
1	Me	Ph	CO ₂ Et	CO ₂ Et	89
2	Me	Ph	CN	CO ₂ Et	78
3	Me	Me	CO ₂ Et	CO ₂ Et	19
4	Me	Cyclohexyl	CO ₂ Et	CO ₂ Et	48
5	Me	Ph	NO ₂	Me	64
6	Bn	Ph	CO ₂ Et	CO ₂ Et	73
7	Bn	Ph	CO ₂ Et	CN	79
8	Bn	Ph	CN	CN	73
9	Ts	Ph	CO ₂ Et	CO ₂ Et	84
10	Boc	Ph	CO ₂ Et	CO ₂ Et	ND
11	Me	Ph	CN	CN	ND

Later, the same research group developed a Pd-catalyzed three component approach toward the synthesis of stereodefined pyrrolidines **532** (Scheme 110).³⁰⁸⁻³⁰⁹ This one-pot process is initiated by the conjugate addition of a propargylamine to a gem-diacetate olefin followed by a carbopalladation involving an aryl halide (or vinyl triflate).³¹⁰ The reaction is carried out in a THF-DMSO mixture in the presence of NaH and 5 mol% PdCl₂(PPh₃)₂ at room temperature and the expected pyrrolidines **532** were obtained in good yield.

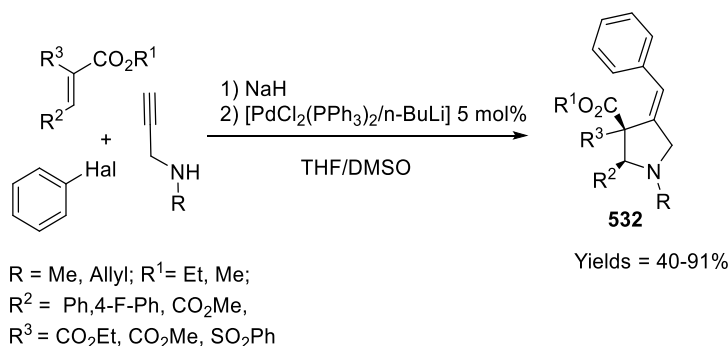
Scheme 110. Synthesis of pyrrolidines 532.

In 2006, Morikawa *et al.* reported a similar approach to synthesize functionalized methylenepyrrolidines from propargylamines through both zinc- and indium-promoted

conjugate addition-cyclization reactions.³¹¹ The reaction can be carried out both in the presence of a stoichiometric amount of ZnBr₂ or InBr₃ at room temperature or with a catalytic amount of InBr₃-Et₃N at 80°C.

Radical cyclization of *N*-allyl-propargylamines using radical transfer agents is a versatile method for constructing substituted heterocycles.³¹² A variety of radical transfer agents can be utilized to achieve the radical chain process. Hosomi and co-workers demonstrated that allylstannanes **534** are good radical transfer agents for the radical cyclization of 1,6-enynes to highly functionalized carbocycles. This cyclization reaction was also applied to the synthesis of pyrrolidines **535** starting from allyl-propargylamines **533**. According to the proposed mechanism of reaction, propargylamines **533** react with the stannyl radical generated by the action of AIBN on the allyl stannane **534** to provide pyrrolidines **535** in good yields (Scheme 111).³¹³

Scheme 111. Radical cyclization reactions of *N*-allyl-propargylamines.

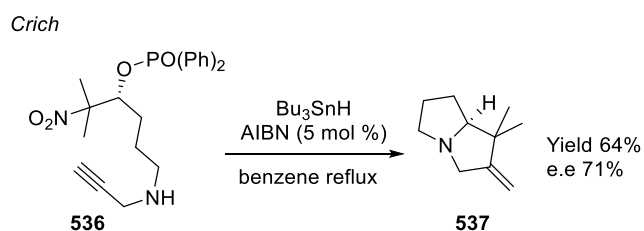
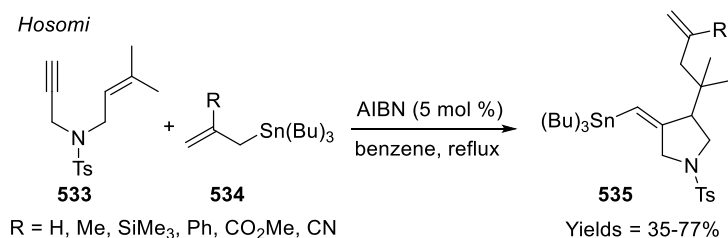

Later, in 2003, Crich and co-workers reported a similar process. They developed a stereoselective cyclization process for the synthesis of functionalized pyrrolidines **537** from β-nitrophosphate radical cation precursors **536** by treatment with Bu₃SnH and AIBN in benzene at reflux.³¹⁴

An interesting approach to synthesize substituted five-membered ring nitrogen heterocycles has been described by Ojima and co-workers in 2002 who reported a rhodium catalyzed carbonylative silylcarbocyclization reaction of enynes.³¹⁵ The reaction was carried out in the presence of $\text{Rh}_4(\text{CO})_{12}$ as a catalyst, Me_2PhSiH and $\text{P}(\text{OEt})_3$, at 105°C and 20 atm of CO and led to the formation of the desired pyrrolidine **539** in 86% yield. The authors proposed a mechanism of the reaction as shown in Scheme 112.

Scheme 112. Rhodium catalyzed carbonylative silylcarbocyclization reaction of enynes.

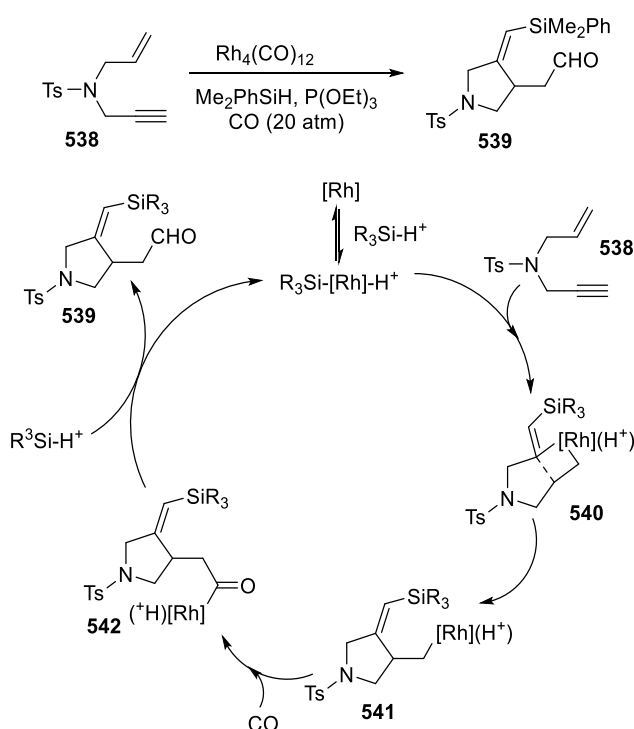

Finally, it is worth mentioning the protocol developed by Kushwaha *et al.* in which an indium(III)-catalyzed tandem synthesis of 2-alkynyl-3,3-dichloropyrrolidines led to the *in situ* formation of propargylamines which readily transform to pyrrolidines.³¹⁶ The reaction proceeds in a single synthetic step *via* an addition of acetylenes to α,α,γ -trichloroaldimines leading to the *in situ* production of trichloropropargylamines which spontaneously cyclize to afford the desired pyrrolidine in good yields.

3.4 Synthesis of indoles and indole derivatives from propargylamines

Indoles represent an important class of compound with many applications in medicinal and material chemistry. Despite many different approaches having been developed to access this class of compounds, only a small number use propargylamines as starting materials. An early and interesting approach to indole derivatives has been described in 1989 by Yasukouchi and Kanematsu. The authors reported the synthesis of **546** from the propargylamine derivative **543** through an allene intramolecular Diels-Alder reaction. Propargylamine **543** was converted into the allene intermediate **544** by treatment with HCHO, DIPA and CuBr as catalysts in refluxing dioxane. Under these reaction conditions, the allene spontaneously cyclizes into indoline **545** which is finally converted into indole **546** by treatment with chloranil in refluxing toluene (Scheme 113).³¹⁷

Scheme 113. Synthesis of indole derivative 543.

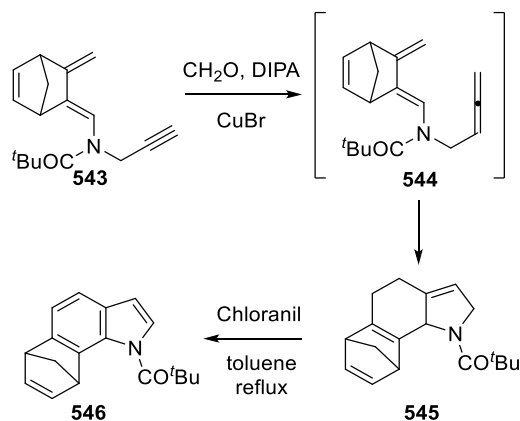

More recently, Kazmaier and Lin described an interesting two-step hydrostannation-cyclization reaction of propargylamines which led to the formation of indole derivatives **549**. Propargylamines **547** were treated with Bu₃SnH and MoBI₃ in the presence of hydroquinone, to suppress radical hydrostannations, and CO, to prolong the lifetime of the catalyst; affording stannane derivatives **548** in good yields. These latter were treated with 2 mol% of [(allyl)PdCl₂] and PPh₃ (4 mol%), affording indoline derivatives **549a** in variable amounts alongside the indole **549b**.³¹⁸ Table 30.

Table 30. Hydrostannation-cyclization of propargylamines.

Entry	R ¹	R ²	Time (h)	Yield (%)	
				549a	549b
1	COOEt	H	4	84	Traces
2	Ac	Me	2	86	7
3	Ac	Br	4	56	26
4	Ac	Br	20	8	82
5	COOEt	H	48	58	0

Beller reported an efficient approach to 3-amidoindoles **552** from commercially available arylhydrazines **550** and propargylamines **551** through a zinc mediated one-pot procedure. Indoles **552** were obtained in excellent regioselectivity and up to 94% yields. Either ZnCl₂ or ZnBr₂ were used as catalysts depending on the substrate (Scheme 114). The indoles synthesized with this approach were finally evaluated as potential GSK-3β inhibitors.³¹⁹

Wang and co-workers reported an interesting Pd-Catalyzed domino cyclization reaction for the synthesis of indoline derivatives **555** from propargylamines **554**.³²⁰ Indolines **555** were obtained in good-excellent yields up to 99% (Scheme 114). The mechanism of the reaction was also investigated and the authors speculated that a Pd-catalyzed Sonogashira coupling should occur first, followed by indole cyclization, regio- and chemoselective *N*-1-acylation and, finally, a 1,4-Michael addition reaction.

Scheme 114. Zn- and Pd-catalyzed synthesis of indoles and indolines.

Beller

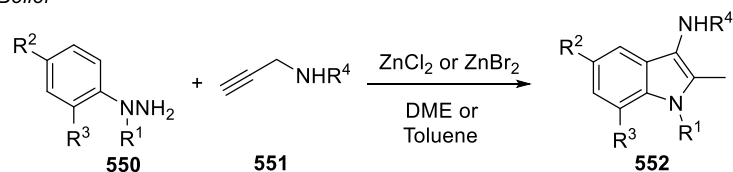

Wang

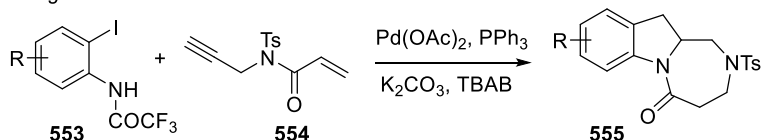

Finally, Nishibayashi and co-workers described an interesting tandem amination-cycloaddition of propargylic acetates to yield 1,2-disubstituted tetrahydroisindoles using (*E*)-2,4-pentadienylamine **557**.³²¹ Treatment of the propargylic acetate **556** with **557** in the presence of $\text{CuOTf}(\text{C}_6\text{H}_6)_{0.5}$ and the chiral ligand (*R*)-Cl-MeO-BIPHEP led to the formation of the bicyclic amine **558** in a single step. The propargylation reaction of the amine **556** leads first to the diene intermediate **559** which, under the same reaction conditions spontaneously gives a Diels-Alder reaction, to afford the desired tetrahydroisindole **558** in good yields (Scheme 115).

Scheme 115. Tandem amination - cycloaddition reaction.

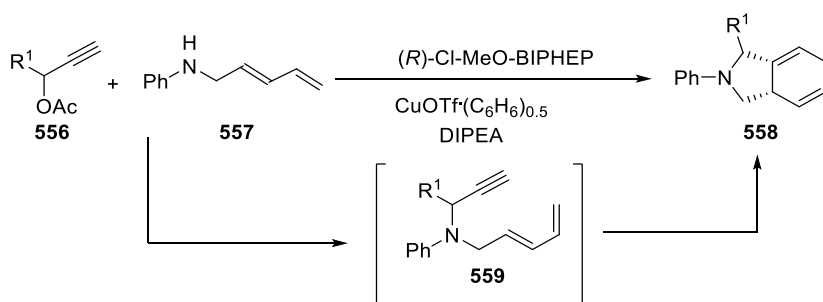

3.5 Synthesis of pyrazines and pyrazoles from propargylamines.

Only a few synthetic examples of the production of pyrazine derivatives from propargylamines have been reported in the literature. In 2014, Alcade and co-workers described the synthesis of pyrazine derivatives **560** from commercial propargylamine. The treatment of different aldehydes with propargylamine in the presence of $[(\text{PPh}_3)\text{AuNTf}_2]$ as catalyst led to pyrazine derivatives **560** in high yields (Scheme 116). Interestingly, it has been shown that the addition of 5 equivalents of H_2O accelerates the gold-catalyzed reaction.³²²

Scheme 116. Gold-catalyzed synthesis of pyrazines 560.

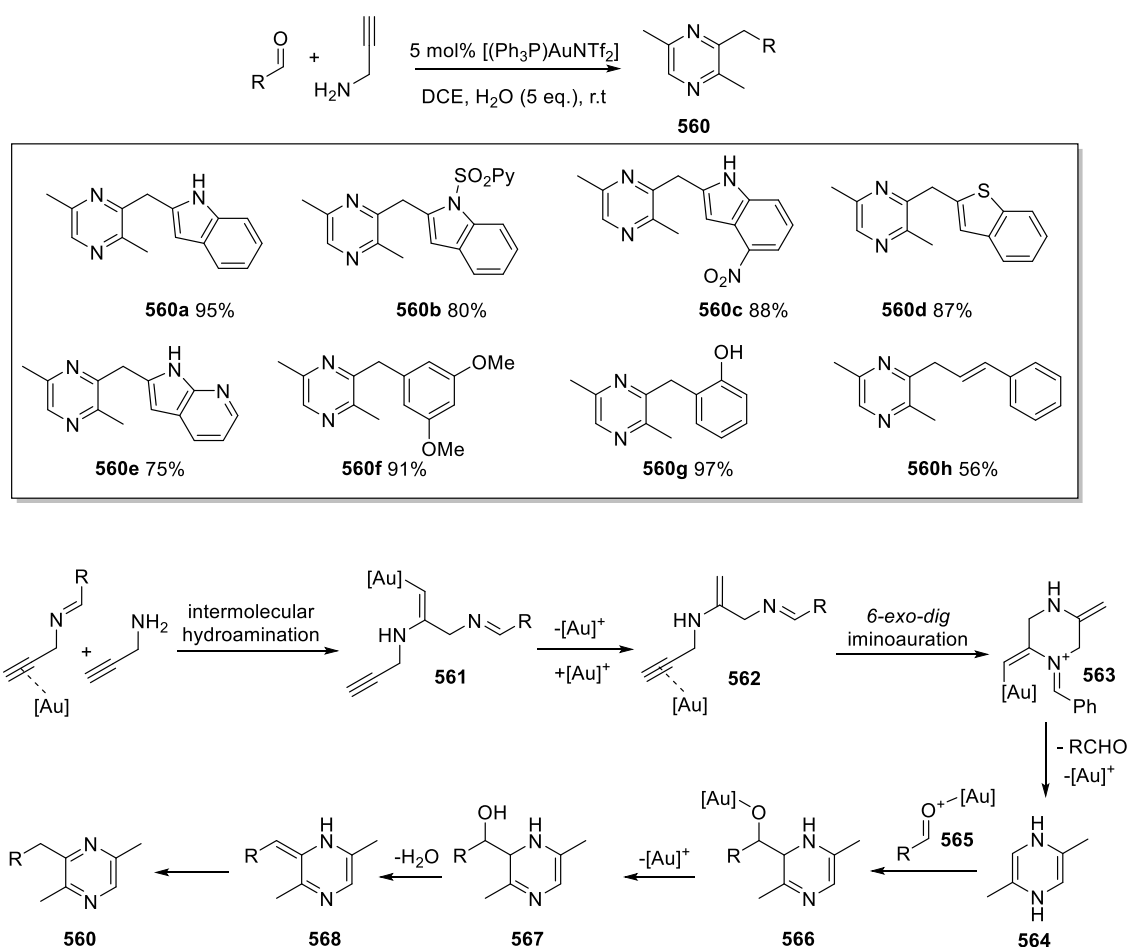

Although the gold catalyzed transformation tolerates a large variety of substituents on the aromatic aldehyde ring, the reaction does not work well when it is carried out with aliphatic aldehydes and secondary propargylamines. DFT calculations have been carried out in order to elucidate the mechanism of the reaction. The authors suggested that the gold catalyst may have a dual role; in the activation of the propargylamine to favor the intermolecular

hydroamination step and the *6-exo-dig* iminoauration step leading to **563**, as well as in the activation of the aldehyde leading to the formation of intermediate **566**. These options are illustrated in Scheme 116.

In 2015, a similar work describing a gold-catalyzed cascade annulation reaction of propargylamine with aldehydes was reported by Hua and co-workers. The reaction leads to the synthesis of 3-substituted 2,5-dimethylpyrazines **569** in high yields. The authors proposed a reaction mechanism which is slightly different from that proposed by Alcaide. They suggested that the propargylamine undergoes a gold catalyzed dimerization reaction to afford the α -amino enamine **570** which in turn isomerizes to **571**. This latter undergoes an aldol addition with an aldehyde, affording α -amino imine intermediate **572** which in turn leads to the formation of the desired pyrazine **569** through a gold catalyzed intramolecular hydroamination and dehydration/isomerization (Scheme 117).³²³

Scheme 117. Au-catalyzed synthesis of pyrazines 569.

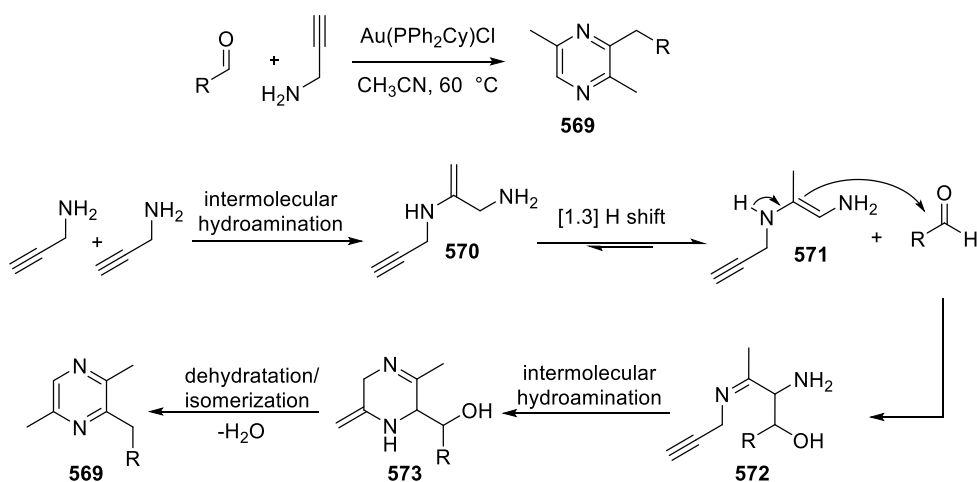

Chen and co-workers recently described the synthesis of pyrazole derivatives **575** from propargylamines **574**. Compounds **574** were first reacted with *m*-CPBA and hydrazines and the pyrazoles **575** were obtained in good yields. The reaction proceeds through the oxidation of the propargylamine **574** nitrogen followed, possibly, by the formation of an isoxazolinium intermediate. This latter is in turn converted into the pyrazole **575** by reaction with the

hydrazine (Scheme 118). Interestingly, when azides, hydroxylamine or amidines were used in place of hydrazides, the corresponding triazole, isoxazole and pyrimidine products were obtained.³²⁴

Scheme 118. Synthesis of pyrazoles 575 from propargylamines.

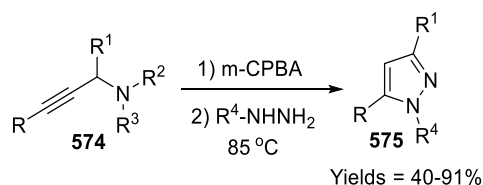

3.6. Synthesis of pyridines and pyridine derivatives from propargylamines

Propargylamines have been widely used as substrates for the synthesis of pyridines as well as poly-hydropyridines through a variety of different approaches.

3.6.1 Synthesis of pyridines. An early example of synthesis of pyridines from propargylamines was reported by Cacchi *et al.* in 2008. The authors described the synthesis of pyridines **577** from *N*-propargylic-β-enaminones **576** through a copper catalyzed *6-endo-dig* cyclization as shown in Scheme 119. The propargylamine derivative **576** is supposed to form a complex with copper followed by intramolecular cyclization to afford intermediate **578**. Finally, the dihydropyridine **579** is formed and immediately oxidized into the pyridine **577** with concomitant regeneration of the copper catalyst.²⁸⁷

Scheme 119. Copper catalyzed cyclization of propargylamines into pyridines.

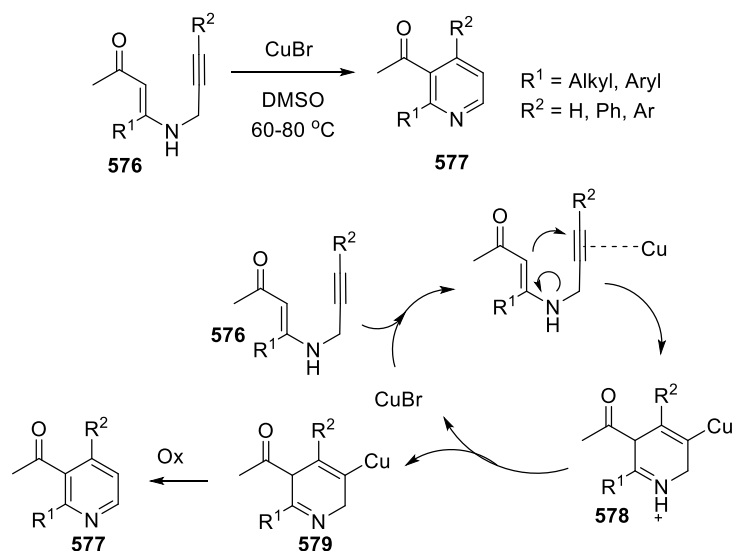

A similar approach was later described by Wan and co-workers who reported the synthesis of pyridine derivatives **581** via an aza-Claisen rearrangement/ 6π -electrocyclization/elimination cascade of *N*-sulfonyl-*N*-propargylic- β -enaminones **580**. The mechanism of the reaction is described in Scheme 120. The substrate **581** gives an aza-Claisen rearrangement to afford **582** which is in turn converted to **583** by 1,3-H shift. The dihydropyridine **584** is then formed via 6π -electrocyclization. Finally, elimination of sulfonic acid led to the formation of pyridine **581**.³²⁵ Interestingly, the same authors also described a method to convert the substrate **580** into the dihydropyridine **585** or the iodo derivative **586** by simply changing the reaction conditions.³²⁶

Scheme 120. Synthesis of pyridines via aza-Claisen rearrangement/ 6π -electrocyclization/elimination cascade.

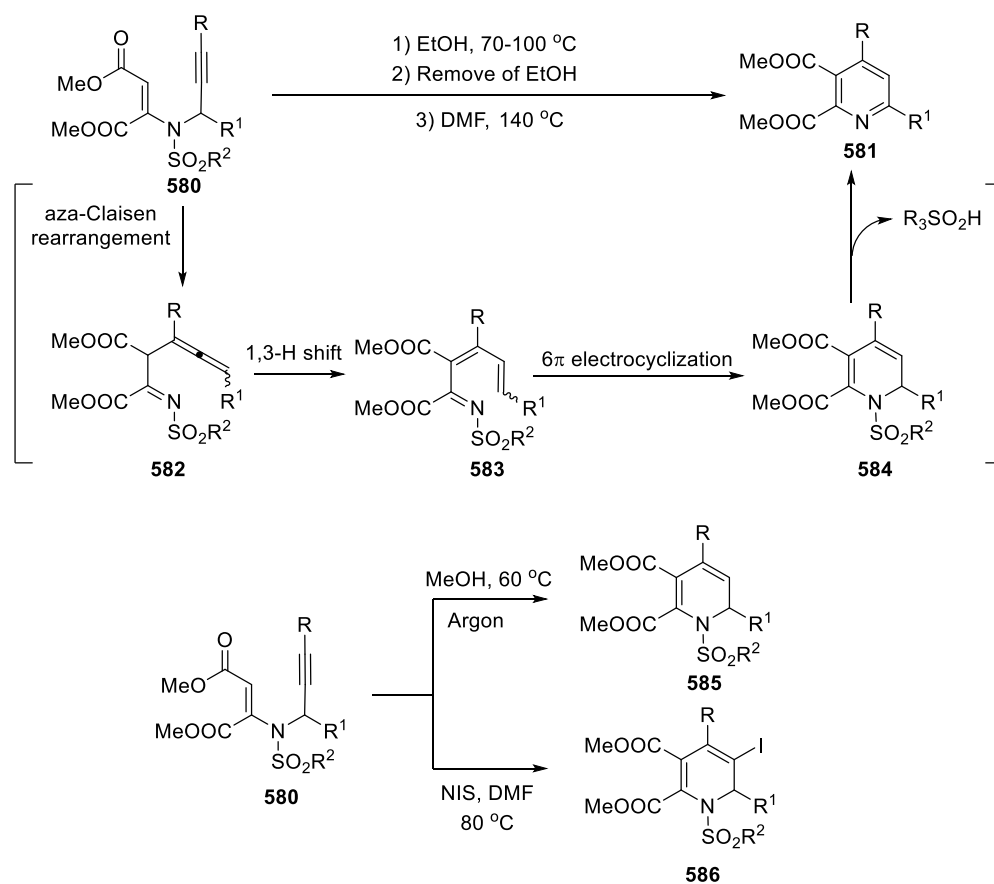

Similarly, Zora and co-workers described the synthesis of iodo-pyridine derivatives **588** from *N*-propargylic- β -enaminones **587**. The reaction of **587** with I_2 proceeds under relatively mild conditions and in the presence of the weak base $NaHCO_3$. Several pyridines **588** were synthesized with variable yields up to 85%. The author suggested that iodine should first attack the triple bond leading to the iodonium ion intermediate **589**, which is converted into **590** via a *6-endo-dig* cyclization. Deprotonation of the latter compound leads to dihydropyridine **591** which is converted into **588** by oxidation with I_2 or O_2 (Scheme 121).³²⁷

Scheme 121. Synthesis of iodo-pyridine derivatives 588.

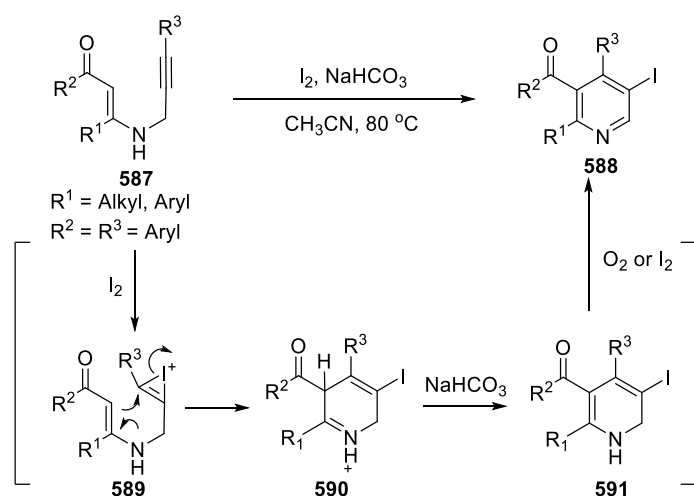

An interesting approach to pyridine from *N*-propargylic enaminones has been recently described by Cheng and co-workers. Treatment of the enaminone **592** with various heterocyclic nucleophiles such as indoles, pyrroles, imidazoles or pyrazoles in the presence of NaOH led to the formation of a series of substituted pyridines **593** in short reaction times. The proposed mechanism is illustrated in Scheme 122. An initial propargyl–allenyl isomerization–enolization cascade reaction leads to iminoenolate intermediate **594**. The intramolecular *7-exo-dig* cyclization of **594** provides the 1,4-oxazepines **595**, which subsequently isomerize to give the epoxide intermediate **597** via a 6π -electrocyclization/walk rearrangement cascade. Epoxide ring opening with *N*-heterocycle nucleophiles proceeds via $\text{S}_{\text{N}}2$ substitution, generating trans-2,3-dihydropyridine intermediate **598**. Finally, the dehydrative aromatization leads to the final pyridine **593**.³²⁸

Scheme 122. Synthesis of pyridines **593**.

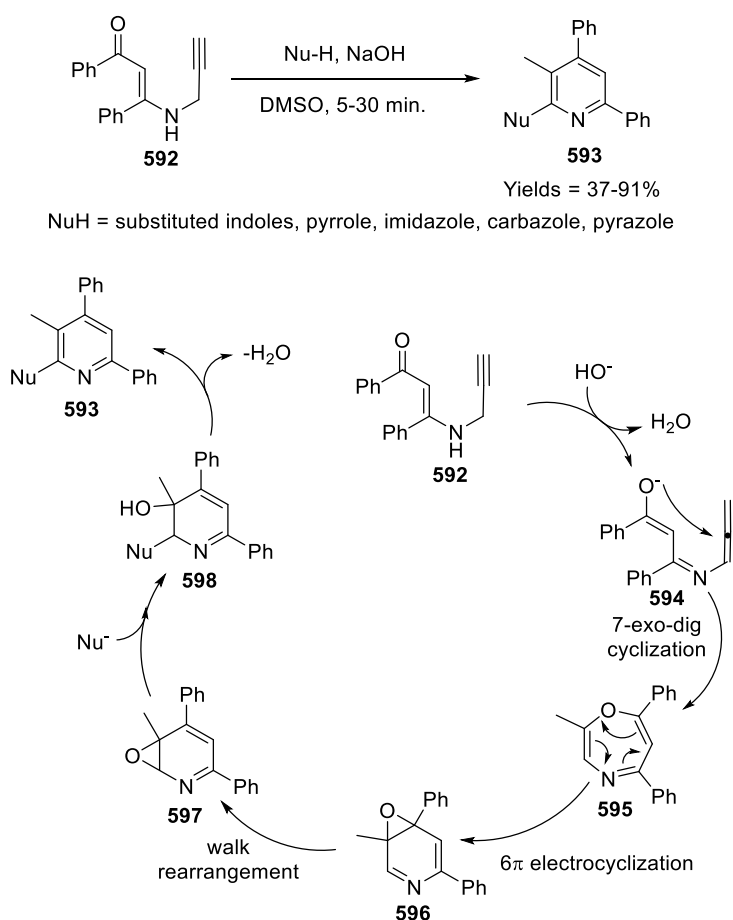

Commercial propargylamine has been used by Abbiati *et al.* as a substrate for the synthesis of a series of pyridine derivatives.³²⁹ Propargylamine was reacted with different ketones in the presence of $\text{NaAuCl}_4 \cdot 2\text{H}_2\text{O}$ as a catalyst and led to the synthesis of a series of pyridine derivatives **600** in good yields. The formation of pyridines **600** was suggested to occur through the sequential amination of carbonyl compounds followed by a regioselective 6-*endo-dig* cyclization of the *N*-propargylenamine intermediate **599** and subsequent aromatization (Scheme 123). Au(III) salts proved to be the most efficient and selective catalysts. However, the reaction was also shown to work well in the presence of $\text{Cu}(\text{NO}_3)_2 \cdot 3\text{H}_2\text{O}$ as catalyst.

Finally, propargylamine has been used as building block by Wei *et al.* for the synthesis of pyridines through the direct condensation with cinnamaldehyde in the presence of DBU as a

base.³³⁰ The reaction proceeds through a 6π -3-azatriene electrocyclization reaction and a [1,3] hydrogen shift sequence as shown in Scheme 123.

Scheme 123. Synthesis of pyridines 600 and 601 from propargylamine.

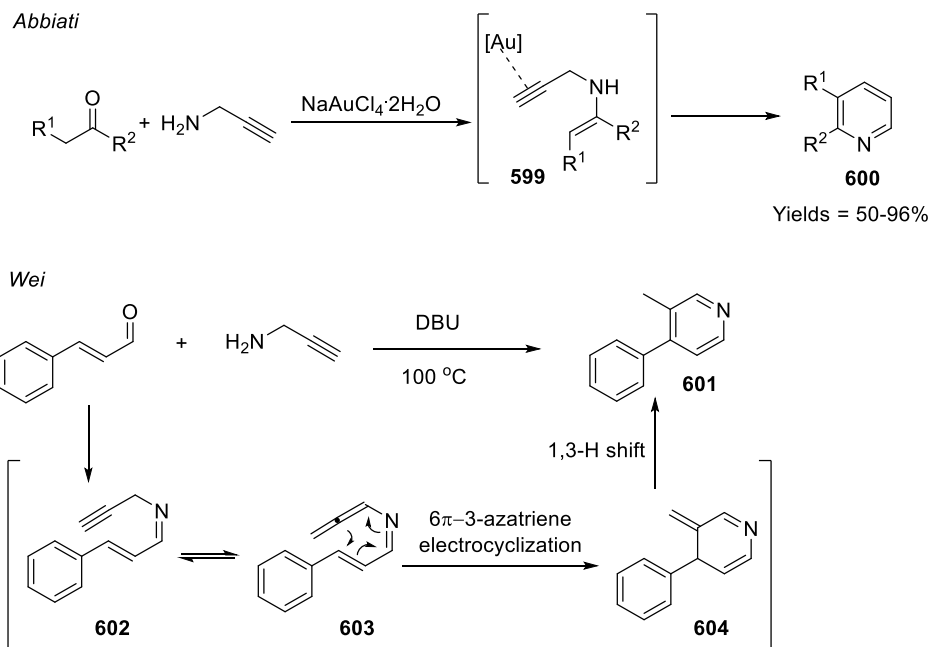

3.6.2 Synthesis of dihydropyridines. As shown in the previous section, *N*-propargyl- β -enaminones can be used as precursors for the synthesis of pyridines. Generally, these substrates are first converted into dihydropyridines which, after aromatization, afford the corresponding pyridines. In addition to previous methods, several other examples of metal catalyzed cyclization of *N*-propargyl- β -enaminones to selectively yield dihydropyridines have been reported in recent literature.

Saito and coworkers first described the synthesis of the 1,2-dihydropyridine **606** from the propargylamine derivative **605** through a *6-endo-dig* cyclization process using $[(IP)Au(MeCN)]BF_4$ as catalyst. Interestingly, the reaction worked as planned when CH_2Cl_2 was used as solvent whilst when hexafluoroisopropanol (HFIP) was used as co-solvent, a five membered pyrrole analogue was formed as the major cyclization product (Scheme 124).²⁷⁸

A similar gold-catalyzed approach has been reported by Fañanas and co-workers who synthesized a series of 2,5-dihydropyridines from *in situ* generated *N*-propargyl- β -enaminones in the presence of NaAuCl₄ as catalyst.³³¹

Other metal catalysts such as AgNO₃³³² and [Cu(Xantphos)(CH₃CN)]PF₆³³³ were later employed by other authors to synthesize dihydropyridine derivatives under similar reaction conditions (Scheme 124).

Scheme 124. Metal catalyzed syntheses of dihydropyridines 606.

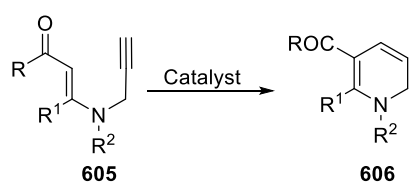

R = OEt; R¹ = COOEt; R² = Ts;
Cat = [(IP)Au(MeCN)]BF₄

R = CF₃; R¹ = Alk; R² = Ph, Bn, Pr;
Cat = AgNO₃

R = OMe, Ph; R¹ = Alk, R² = Ph, Me, H; R² = Bn;
Cat = [Cu(Xantphos)(CH₃CN)]PF₆

Dihydropyridines can be also synthesized from vinyl-propargylamines through a metal catalyzed cycloisomerization as shown by Kim and Lee in 2006. The substrate **607** was treated with [Rh(C₂H₂)₂Cl]₂ as catalyst in the presence of a phosphine ligand P(4-F-C₆H₄)₃ and a stoichiometric amount of DABCO, leading to the desired dihydropyridine **608**. Interestingly, the same protocol was also used for the synthesis of bicyclic pyridine derivatives (Scheme 125).³³⁴

Vinyl-propargylamines have been also used as substrates for the synthesis of dihydropyridine by the research group of Menon. Treatment of compound **609** with the (JohnPhos)Au(CH₃CN)SbF₆ catalyst led to the five membered pyrrole ring **610** as the main reaction product. However, when the authors performed the same reaction using AgSbF₆ as co-catalysts with gold catalyst, the dihydropyridine **611** was obtained as the sole reaction

product. Optimization studies were carried out and the best catalyst system was found to be $\text{Ph}_3\text{PAuCl-AgSbF}_6$. Several dihydropyridines **611** were then synthesized with yields of up to 98%. The proposed mechanism of the reaction involves a metal-mediated propargyl-Claisen rearrangement which leads to intermediate **612**. This latter can be converted into the pyrrole **610** by gold-mediated *5-exo-dig* cyclization and subsequent aromatization, whilst the dihydropyridine **611** was formed through the tautomerization of **612** into the aza-triene **613** followed by a 6π -aza-electrocyclization (Scheme 125).³³⁵ A similar approach to dihydropyridines has been also described recently by Wang and co-workers.³³⁶

Scheme 126. Au-catalyzed cascade reaction of *N*-propargylamines and alkynes.

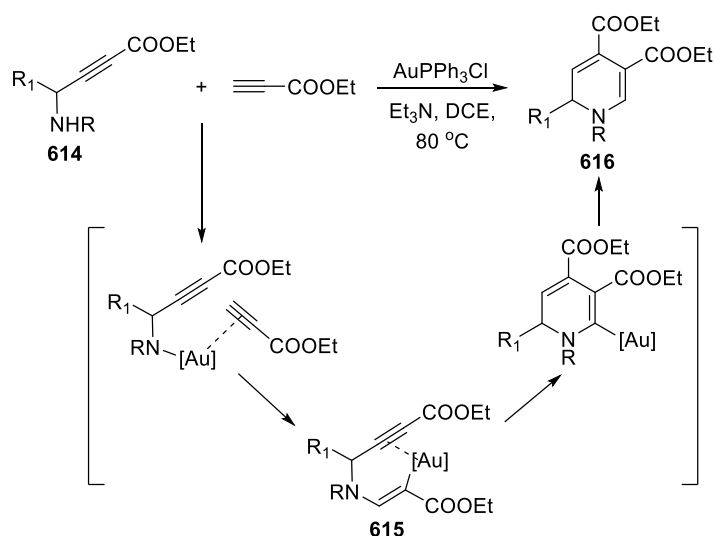

3.6.3 Synthesis of tetrahydropiperidines. Tetrahydropyridines (THPs) can be obtained from propargylamines through intramolecular RCEYM reactions. Takahata reported the asymmetric synthesis of 2-propylisofagomine³³⁸ and isophagomine³³⁹ from the THP **618** which was in turn obtained through RCEYM of the propargylamine **617**. The enyne **617** was treated with Grubb's 1st gen. catalyst **GI** (4 mol%) leading to the formation of **618** in good yields (Table 31). Interestingly, the presence of the free hydroxyl group proved to be crucial to accelerate and improve the yield of the metathesis reaction. In addition, the presence of ethylene atmosphere proved to be beneficial for the outcome of the reaction, leading to product **618** in 96% yield, compared to 30% under argon atmosphere.

Table 31. Synthesis of THPs via RCEYM.

Entry	R^2	Atmosphere	THP Yield (%)
1	H	Argon	32
2	H	Ethylene	96

3	OH	Argon	>99
4	OBn	Argon	44
5	OTBDPS	Argon	7

Other examples of synthesizing THPs *via* enyne metathesis reaction have been described by Kotha *et al.* who reported the synthesis of **620** as precursor of tetraisoquinoline-3-carboxylic acids (Tics) **621**,³⁴⁰ and by Katritzky and co-workers who synthesized the vinyl THP **623** *via* RCEYM by treatment of propargylamine **622** with **GI**.³⁴¹ Scheme 127.

Scheme 127. RCEYM approaches to THPs **620** and **623**.

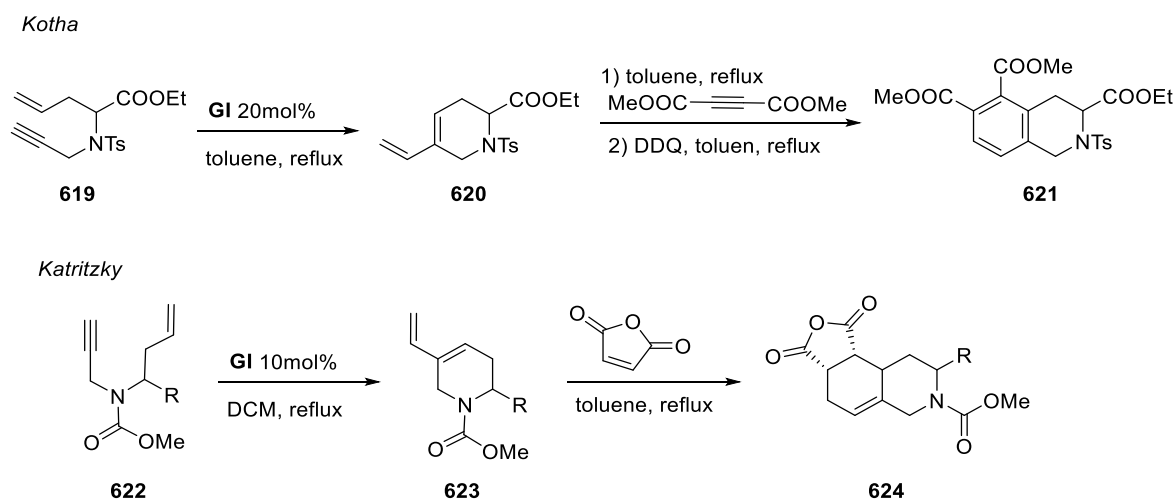

3.6.4 Synthesis of piperidines. An elegant example of the synthesis of piperidine substrates from propargylamines has been reported in 2009 by Kerr through a zinc catalyzed tandem cyclopropane ring-opening/Conia-ene cyclization reaction. The authors reasoned that a 1,1-cyclopropane diester could be opened with a propargylamine, to provide a substrate intermediate suitable for Conia-ene cyclization, which is finally able to yield a piperidine product. Cyclopropane substrates **625** were thus reacted with benzylpropargylamine in the presence of $\text{Zn}(\text{NTf}_2)_2$ in refluxing benzene, affording piperidine derivatives **626** in excellent yields of up to 99%. The authors proposed the mechanism illustrated in Scheme 128. Initial

coordination of the diesters by zinc facilitates the nucleophilic attack of the propargylamine and the cyclopropane ring opening. Subsequent coordination of the alkyne allows the malonate addition and ring closure *via* Conia-ene cyclization.³⁴²

Scheme 128. Tandem cyclopropane ring-opening/Conia-ene cyclization reaction.

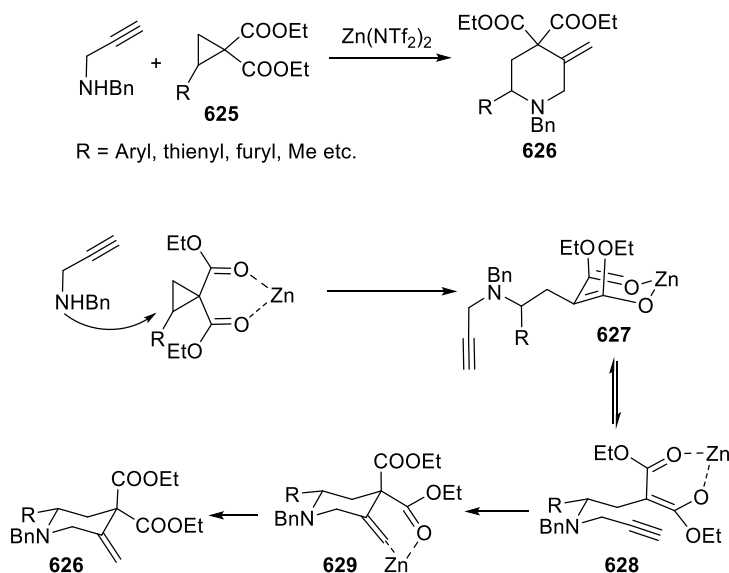

3.7 Synthesis of quinolines and quinoline derivatives from propargylamines

Several approaches for the synthesis of quinoline derivatives from propargylamine substrates have been reported in the literature. Most of these methods relies on the metal catalyzed hydroarylation of *N*-aryl-propargylamines through the insertion of the alkyne triple bond into an aromatic C-H bond to form a new C(sp²)-C(sp²) bond.

3.7.1 Synthesis of quinolines. The first approach to quinolines from *N*-aryl-propargylamines was reported in 2002 by Huma *et al.* who discovered that treatment of propargylamine derivative **630** with CuCl in refluxing THF afforded the corresponding quinoline **633** in good yield (Scheme 129). The authors suggested that **630** undergoes an allenyl isomerization into **631**. Then, coordination of Cu(I) to the terminal bond of the allene would give intermediate **632** which will trigger an intramolecular nucleophilic attack to form the quinoline **633** after a 1,2-shift, proton transfer and hydride transfer (oxidative process).³⁴³

It is noteworthy that the authors also obtained the quinoline product when they performed the A^3 coupling reaction between PMP-NH₂, an alkyne and benzaldehyde under the same reaction conditions and in the presence of CuCl.

Scheme 129. Copper catalyzed cyclization of propargylamines into quinolines.

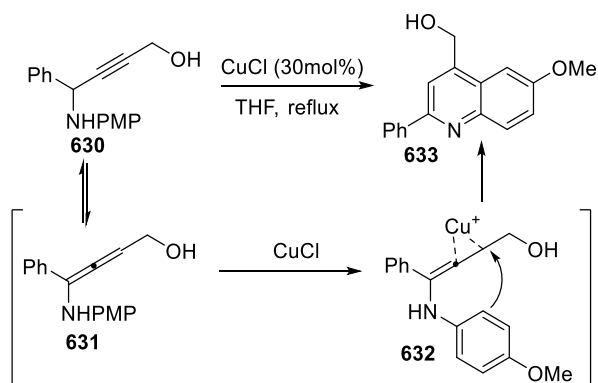

Following this preliminary work, the conversion of *N*-aryl-propargylamines into quinoline derivatives has since been widely investigated by several research groups. In 2008, Wang and co-workers described the synthesis of a variety of quinolines by treating the propargylamines **634** with AuCl₃ in MeOH at room temperature.³⁴⁴ Later, Fu expanded the scope of the reaction using a Ph₃PAuCl/AgOTf system in refluxing toluene,³⁴⁵ whilst Litinas described the synthesis of quinolines using an Au/TiO₂ catalytic systems.³⁴⁶ In all cases, a gold- π -alkyne complex is supposed to be formed. Then a *6-endo-dig* cyclization occurs, leading to the formation of a dihydroquinoline intermediate **636** which is in turn converted into quinoline **635** by oxidation with air as shown in Scheme 130.

Scheme 130. Mechanism of the Au-catalyzed synthesis of quinolines.

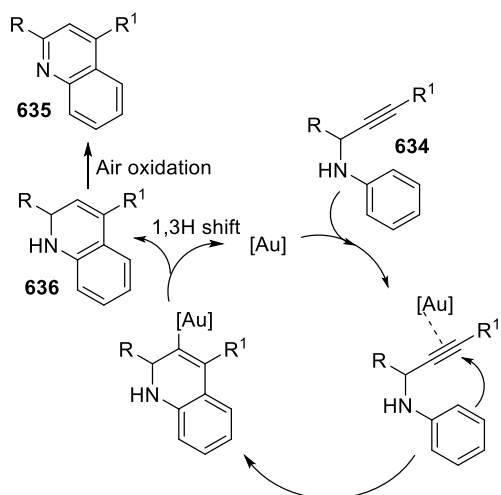

Other metal catalysts have been used to synthesize quinolines from propargylamines. An interesting approach has been described by Roy and co-workers who synthesized quinolines **639** via an intramolecular cyclization and concomitant detosylation of *N*-aryl-*N*-tosyl-propargylamines **637** using stoichiometric amounts of FeCl₃ as catalyst. The detosylation step is promoted by FeCl₃ leading to the aromatization of the ring.³⁴⁷ Schöfberger and co-workers reported a similar approach to quinolines **642** and **645** using SnCl₂·H₂O or In(0) as catalysts in the presence of 3M HCl.³⁴⁸ It is noteworthy that the internal alkyne **640** led to the quinoline **642** whilst the quinoxaline **645** was obtained as the only reaction product when the same reaction was performed on the terminal alkyne **643** (Scheme 131). Mechanistic studies were carried out by the authors and it was found that a hydration step of the alkyne should occur in the early phases of the reaction leading to a ketone intermediate. This is in agreement with literature where tin and indium are known to be able to facilitate hydration reactions of alkynes to generate ketones.

Scheme 131. Fe-, Sn- and In-catalyzed synthesis of quinolines.

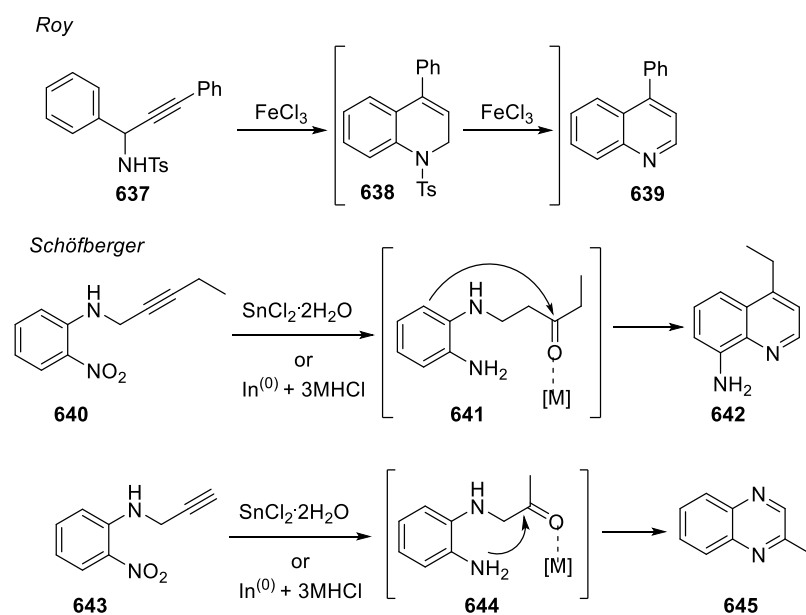

As previously mentioned, quinolines can be accessed directly *via* the A^3 coupling reaction of alkynes, aldehydes and anilines. Several examples of this reaction have been reported in the literature. The reaction is supposed to proceed through the formation of a propargylamine intermediate which in turn, under metal catalysis, is converted into the quinoline product through a mechanism similar to those shown above. The reaction can be catalyzed by several metal catalysts such as CuCl ,³⁴³ $\text{AuCl}_3+\text{CuBr}_2$,³⁴⁴ $\text{Cu}(\text{OTf})_2$,³⁴⁹⁻³⁵⁰ FeCl_3 ,³⁵¹ YCl_3 ,³⁵² as well as CuCl -modified montmorillonite,¹²⁶ $\text{B}(\text{C}_6\text{F}_5)_3$,³⁵³ montmorillonite K10,³⁵⁴ HClO_4 -modified montmorillonite³⁵⁵ and Fe_3O_4 nanoparticles.²⁴⁰

An interesting approach to quinolines from propargylamines has been reported by Tang and co-workers. The *N*-propargylanilines **646** were reacted with sulfonylhydrazides in the presence of *tert*-butyl hydroperoxide (TBHP) as oxidant in DCE at 90 °C leading to a variety of quinoline derivatives **647** in good-excellent yields. Other oxidants were screened, however TBHP was found to be the best. The mechanism of the reaction is illustrated in Scheme 132. The sulfonylhydrazide reacts with TBHP and generates a sulfonyl radical. This radical species reacts with the propargylamine triple bond to produce an alkenyl radical **648**. The

intramolecular attack of the radical **648** on the pendant benzene ring provides the radical intermediate **649**. Finally, the oxidation of **649** followed by deprotonation leads to the sulfonated 1,2-dihydroquinoline **650** which ultimately aromatizes in the presence of TBHP.³⁵⁶

Scheme 132. Radical cyclization of propargylamines into quinolines.

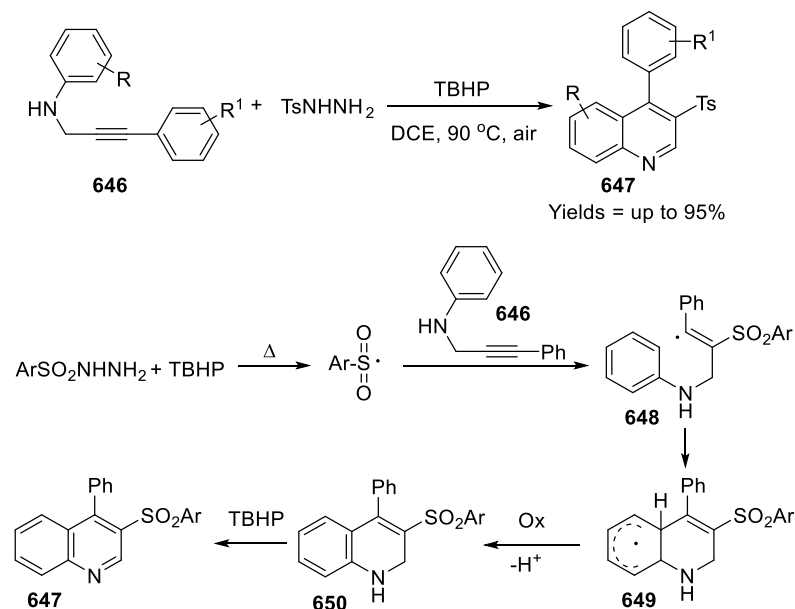

Finally, Larock and co-workers developed a noteworthy strategy to access quinolines from *N*-aryl-propargylamines **651**. These latter can be easily converted into quinolines **652** by electrophilic cyclization induced by electrophilic reagents such as I₂, Br₂, ICl, NBS, and PhSeBr. Treatment of **651** with I₂ in the presence of NaHCO₃ at room temperature led to iodo-quinolines **652a** in high yields in several minutes. Similarly, **651** can be reacted with other electrophilic reagents leading to bromo- and seleno-quinolines **652b-c**. The mechanism illustrated in Scheme 133 has been proposed for this reaction.³⁵⁷

Scheme 133. Electrophilic cyclization of propargylamines.

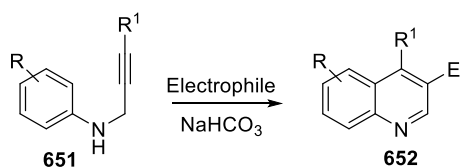

Electrophile = I_2 , Br_2 , ICl , PhSeBr

E = I, Br, SePh

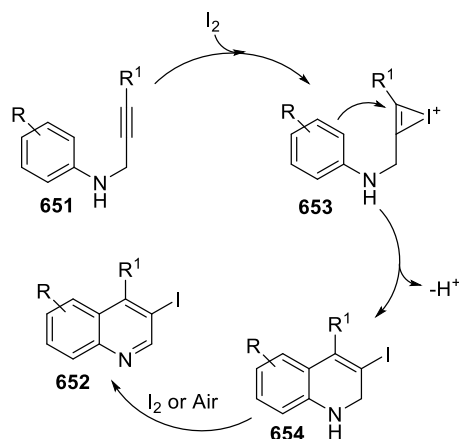

3.7.2 Synthesis of dihydroquinolines. Dihydroquinolines are often intermediates in the synthesis of quinolines. However, selective synthetic approaches to this class of compounds from propargylamines have been also developed. The first general and practical approach for the synthesis of 1,2-dihydroquinolines from *N*-aryl-propargylamines has been reported by Williamson *et al.* in 1995. The authors described the synthesis of **656** from 1,1-disubstituted-propargylaniline **655** through an intramolecular cyclization catalyzed by 10 wt% CuCl . The method is similar to the standard copper catalyzed syntheses of quinolines, but the presence of two substituents on the propargylamine scaffold prevents the final aromatization step. Several dihydroquinoline derivatives **656**, were synthesized using this methodology in good yields (Table 32). Moreover, the same authors converted these compounds in the corresponding 3-, 4- and 3,4-functionalized tetraquinoline derivatives *via* chlorination, bromination, and epoxidation of the double bond of **656**.³⁵⁸⁻³⁵⁹

Table 32. Copper catalyzed synthesis of dihydroquinolines.

The reaction scheme shows the conversion of propargylamine **655** to dihydroquinoline **656**. The starting material **655** is an *N*-substituted propargylamine where the nitrogen is attached to a phenyl ring with a substituent *R*, and the propargyl group has substituents *R*¹ and *R*². The reaction conditions are CuCl (10 wt%) in refluxing toluene, yielding the dihydroquinoline product **656**.

Entry	R	R ¹	R ²	Yield (%)
1	Me	Me	Me	75
2	COOEt	Me	Me	56
3	OMe	Me	Me	50
4	Br	Me	Me	43
5	OTMS	Me	Me	54
6	NHAc	Me	Me	82
7	Me	CH ₂ OMe	<i>n</i> Bu	63
8	OMe	CH ₂ OMe	<i>n</i> Bu	60

Similar approaches using different metal catalysts have been reported by other authors. *N*-Tosylated-1,2-dihydroquinolines have been synthesized by the group of Komeyama using Fe(OTf)₃ as catalyst,³⁶⁰ whilst Lee and coworkers used a FeCl₃-AgOTf co-catalytic system.³⁶¹ Ryu and co-workers reported the synthesis of enantiomerically pure *N*-mesyl-1,2-dihydroquinolines using PtCl₄ as catalyst in DCE at 70 °C,³⁶² whilst the gold catalyst IPrAuNTf and the Pd(OAc)₂-CuBr₂ catalytic system have been used by the research groups of Gonzalez³⁶³ and Perumal³⁶⁴ respectively to convert *N*-arylpropargylamines into 1,2-dihydroquinolines.

Finally, an original approach to functionalized dihydroquinolines from propargylamines **657** through a FeCl₃-catalyzed intramolecular alkyne-carbonyl metathesis reaction has been recently developed by Jana and co-workers. The method tolerates a wide variety of functional

groups but is not efficient when terminal alkynes are used. The FeCl₃ catalyst promotes first a carbonyl-alkyne [2+2]-cycloaddition leading to the intermediate **658**, which is then converted into the final dihydroquinoline **659** through a [2+2]-cycloreversion reaction (Scheme 134).³⁶⁵

Scheme 134. FeCl₃-Catalyzed intramolecular alkyne–carbonyl metathesis.

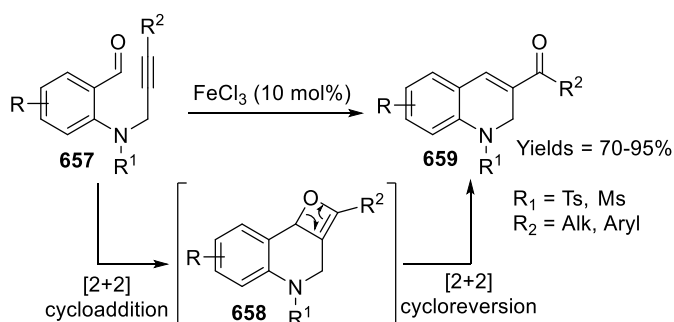

3.7.3 Synthesis of polycyclic quinoline derivatives. Propargylamines and propargylanilines have been used as substrates for the synthesis of polycyclic systems containing a quinoline or a hydroquinoline core. Examples of these syntheses are reported in Scheme 135. Yu and co-workers developed the synthesis of 5-tosyl-6,7-dihydro-5H-indeno[2,1-c]quinolines **661** through the reaction of *N*-aryl-propargylamine **660** with aromatic aldehyde acetals in the presence of a FeCl₃ catalyst. The use of an excess of FeCl₃ led to the one-pot formation of the aromatic derivative **662**.³⁶⁶ Chu and co-workers reported the synthesis of luotonin A and its derivatives through the Yb catalyzed reaction of the propargylamide **663** with glyoxal and anilines. An imine intermediate **665**, supposed to be formed in the early phases of the reaction, undergoes cyclization, followed by an intramolecular aza-Diels–Alder reaction/dehydrogenation/aromatization sequence leading to the pentacyclic product **664**.³⁶⁷

Finally, Arumugam and co-workers described the synthesis of pyrrolo[3,4-b]quinolines **670** *via* a Lewis acid catalyzed reaction of *N*-propargylamine aldehyde **667** with anilines. The reaction proceeds *via* a condensation/cyclization/aromatization sequential mechanism.³⁶⁸

Scheme 135. Synthesis of polycyclic systems containing a quinoline or a hydroquinoline.

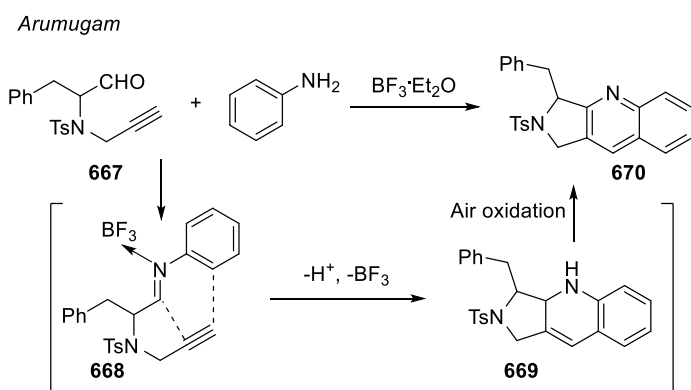
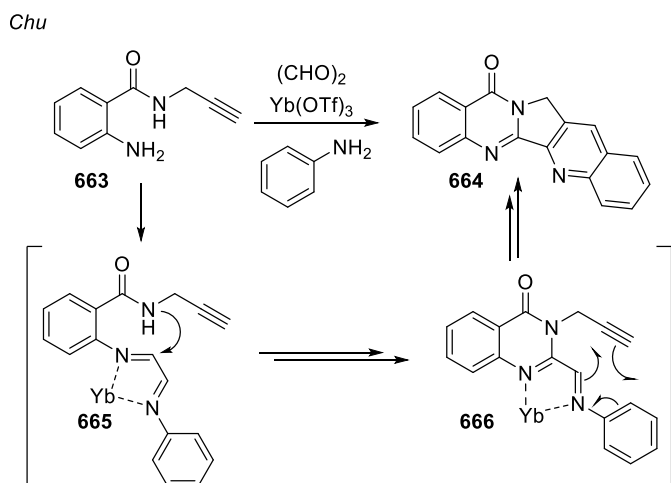
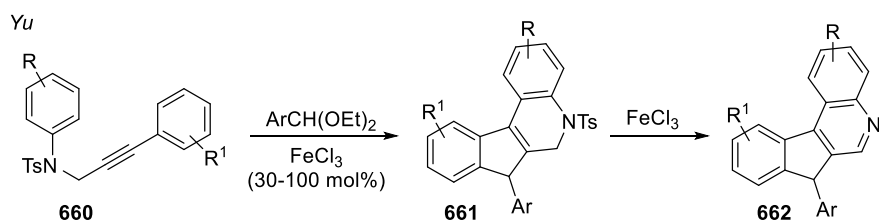

3.8. Synthesis of oxazoles, oxazolidinones and isoxazoles

Oxazoles and their derivatives are a useful member of the azole family, and hold a significant role in the synthetic world, with the group found in a plethora of pharmaceutical drugs such as madumycin II, the antibacterial agent streptogramin, and (-)-hennoxazole A, an effective anti-viral treatment for herpes. They can be also found repeatedly in the natural world, for

example, in the Caribbean sea sponges as neopeltolide alkaloids endowed with antitumor activity.

3.8.1 Base catalyzed synthesis of oxazoles. Propargylamines, and its derivative propargylamides, are an advantageous starting point for the synthesis of substituted oxazoles, with a number of researchers having developed robust and telescoped methods which concede high yields.

The research group of Bogentoft first reported the oxazole formation from propargylamides. The authors treated propargylamides **671** with potassium *tert*-butoxide and discovered that the oxazole fragment **673** had been produced in 25-30% yield.³⁶⁹ The reaction also generated a dihydroquinazoline by-product **674** formed by the migration of the propargylamide group to a neighboring sp^2 carbon (Scheme 136). The finding of the oxazole synthesis showed potential for the process, although demonstrated low conversion and a lack of selectivity for this particular base and substrate combination since a by-product was generated.

Scheme 136. Base catalyzed synthesis of oxazole from propargylamide 671.

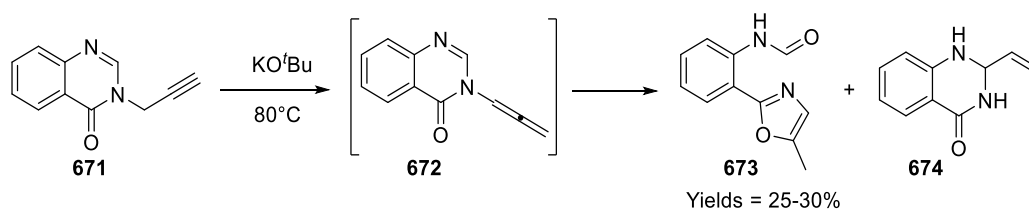

However, this discovery paved the way to inspire a number of researchers to continue to experiment with conditions and reagents for the synthesis of oxazoles from various propargylamides. Nilsson and Hacksell explored new methods for producing oxazoles from propargylamides (Scheme 137). Two bases, NaH and K₂CO₃, were investigated to promote the conversion of propargylamides **675** into oxazoles **676**. The latter were obtained with 54-93% and 95-97% yields respectively in regards to the base used.³⁷⁰

Hacksell's group also found that compound **677** could be converted into oxazole **678** when treated with KOH in THF and in the presence of Bu₄NBr₄. Allene **679** was also isolated from the reaction in 3% yield.³⁷¹

Scheme 137. Base-catalyzed cyclization of *N*-propargylamides to oxazoles.

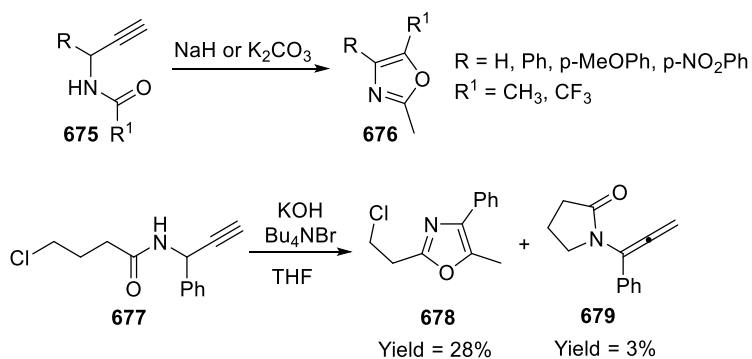

Later, Wipf *et al.* reported the treatment of propargylamide **680** with the non-nucleophilic base NaHMDS at -78 °C finding that these reaction conditions facilitated the formation of the corresponding oxazole **683** in 82-86% yield. Interestingly, the propargylamide **680** has specific stereochemistry with two chiral centers. Only the single diastereoisomer product **683** was detected, suggesting that the cycloelimination reaction does not interfere with the non-participating stereocenters. Presumably the reaction proceeds as described in Scheme 138 through the formation of the cumulene intermediate **681**.³⁷²

Scheme 138. NaHMDS catalyzed cyclization of propargylamine 680.

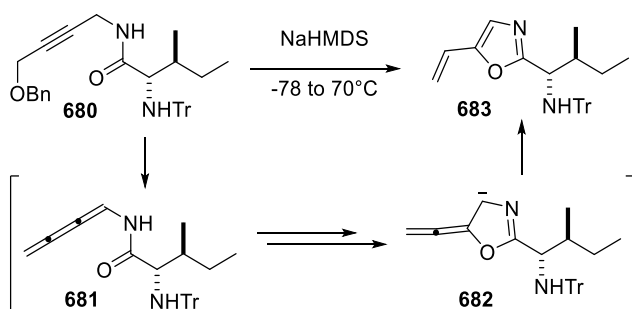

More recently, Yu *et al.* described an interesting approach for the synthesis of oxazoles **687** from propargylamides **684**. The authors found that the treatment of the *N*-tosyl-propargylamine **684** with catalytic amount of DBU (10 mol%) led to oxazole **687** through a cyclization-sulfonyl migration sequence. A number of oxazoles were obtained with this methodology in excellent yields (83-99%). The proposed reaction mechanism is illustrated in Scheme 139. Deprotonation and cyclization of the propargylamide leads to the formation of the zwitterionic intermediate **685**. Then DBU is supposed to facilitate the removal of the tosyl group and its migration to afford the final product **687**. However, the role of DBU in the overall process was not fully understood.³⁷³

Scheme 139. DBU-catalyzed synthesis of oxazole 687.

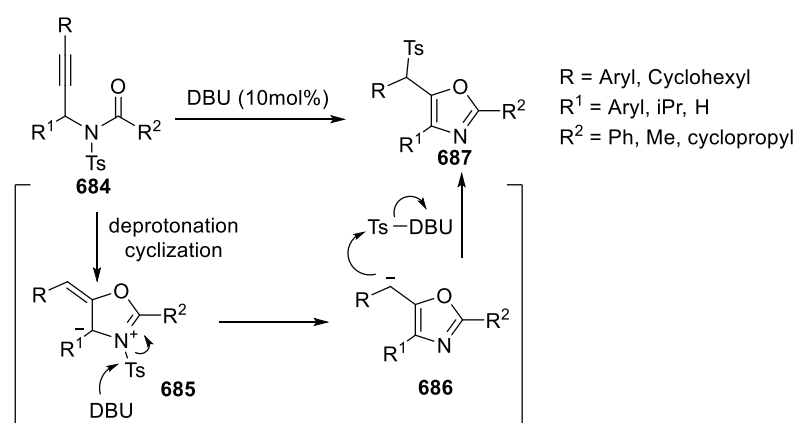

3.8.2 Metal catalyzed synthesis of oxazoles. Several metal catalysts have been found to promote the cyclization of propargylamides into oxazoles. Hg(II) acetate in acetic acid has previously been used as catalyst to cyclize propargylamides to oxazoles in 57% yield. However, this method has a limited application in current times with mercury being carcinogenic and damaging to the environment.³⁷⁴

Arcadi *et al.* were the first to describe the synthesis of the oxazole **689** from propargylamide **688** through a Pd₂(dba)₃ catalyzed Sonogashira coupling reaction with iodobenzene. The authors explored a variety of different reaction conditions and reagent proportions, although often encountered a mixture of products, namely the Sonogashira alkyne coupling product

and the oxazole. Changing the solvent of the reaction, the ligand and the substituents of the propargylamide or aryl iodide had a significant impact on the ratio of desired oxazole product over the Sonogashira coupled alkyne product. They experienced the highest yield of 75% of the desired oxazole **689** with no other side product using Pd₂(dba)₃ with P(2-furyl)₃ as a ligand (Scheme 140).³⁷⁵

Scheme 140. Pd-catalyzed synthesis of oxazoles from propargylamides.

Arcadi et al.

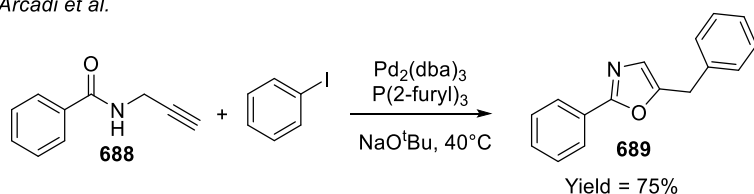

Bacchi et al.

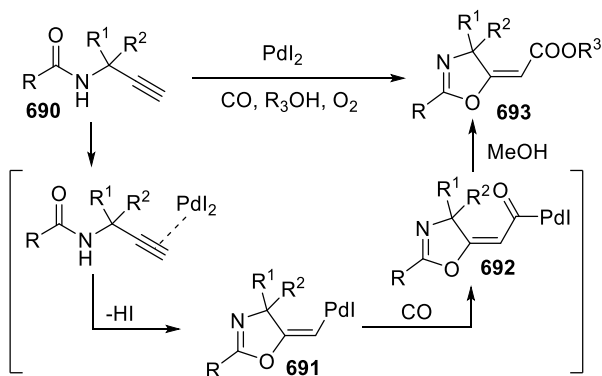

Bacchi *et al.* later developed an interesting palladium catalyzed method to yield substituted-methylene-3-oxazolines **693**. The reactions took place in methanol with CO and air to enable the oxidative carbonylation, leading to a mixture of *E* and *Z* isomers. A palladium complex is first formed with propargylamine **690** followed by cyclization to give **691**. Carbonylation and methanol insertion led to the final product **693** with regeneration of the palladium catalyst (Scheme 140).³⁷⁶

Beccalli *et al.* described an interesting PdCl₂(MeCN)₂-CuCl₂ co-catalyzed synthesis of oxazoles **695** in 37-61% yields from propargylamides **694**. A Pd cyclisation mechanism was proposed as shown in Scheme 141. The palladium coordinates to the alkyne, making it susceptible to attack from the amide group to form a 5-*exo-dig* cyclisation product **696**. The

next few steps have not been confirmed by NMR, but the authors proposed that water hydrolyses the Pd and tautomerization results in the formation of the aldehyde **698b**. The re-oxidation of Pd(0) by CuCl₂ encourages the loss of water from the oxazoline **698b** to yield the carbaldehyde oxazole **695**.³⁷⁷

Scheme 141. Pd-catalyzed synthesis of 695.

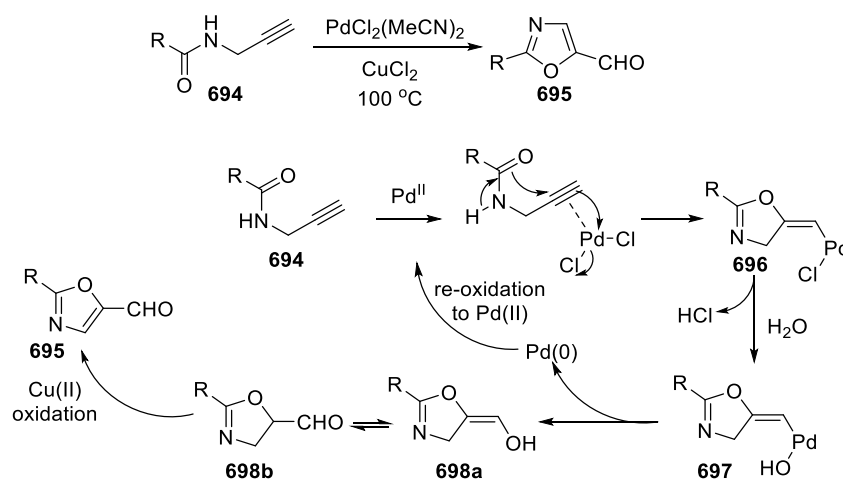

Saito *et al.* described the synthesis of oxazoles **701** using Pd₂(dba)₃ as palladium catalyst and Cy₃P as ligand through a cycloisomerization–allylation reaction of *N*-propargylamides **699** with allyl carbonates **700**. The authors introduced Cs₂CO₃ as base, finding it to greatly increase the yield of the desired allylated product with yields of up to 89% (Scheme 142).³⁷⁸

Yasuhara *et al.* developed a cyclization-carbonylation-cyclization (CCC) coupling reaction using [Pd^{II}(box)] complexes. This complex first favors the cyclization of a propargylamide molecule **702**, which is in turn carbonylated and coupled with a second propargylamide molecule **702**, leading, after further cyclization, to yield bis-oxazolic ketones **703**. This method supported both internal and terminal propargylamines with moderate to excellent yields.³⁷⁹

Scheme 142. Pd-catalyzed synthesis of oxazoles **701** and **703**.

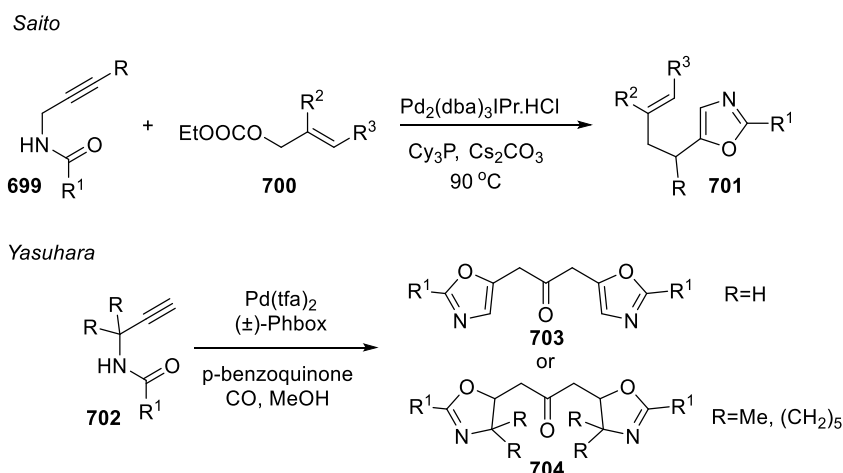

More recently, Mali *et al.* described the selective synthesis of oxazoles **710**, or dihydrooxazoles **706**, from commercially available propargylamine upon treatment with an acyl chloride in the presence of Pd(OAc)₂. The authors observed that when the reaction was carried out in the presence of Et₃N the dihydrooxazole **706** was obtained in good to excellent yields (45-92%), while in the presence of acetic acid the oxazole **710** was formed as the only product in 40-90% yields. The mechanism proposed is shown in Scheme 143.³⁸⁰

Scheme 143. Pd-catalyzed selective synthesis of oxazoles **710** and dihydrooxazoles **706**.

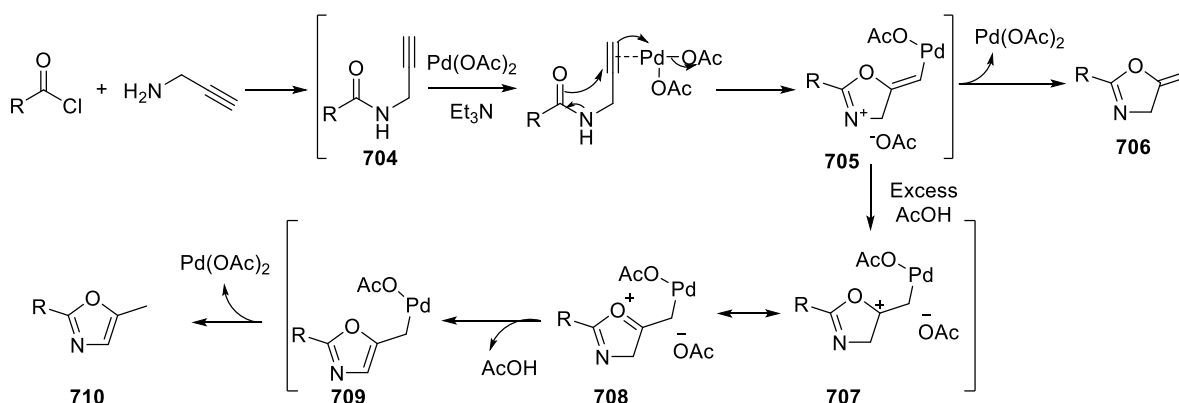

Gold has become an increasingly popular choice as a cyclization catalyst in the synthesis of oxazoles from propargylamines, since it can operate under mild conditions without the need for an inert nitrogen atmosphere and in addition also tolerates a range of functional groups.

The first instance of Au(III) being used as a propargylamine cyclization facilitator to yield oxazoles was in 2004 by Uemura and coworkers. The authors described the cyclization of propargylamides **711** with 5 mol% of AuCl₃ into the corresponding oxazoles **712** with 91% yield. Gold is supposed to form a complex with the triple bond leading to an allene intermediate. Subsequent cyclization leads to the oxazole product (Scheme 144).³⁸¹ The mechanistic conversion of propargylamides to either oxazoles or oxazolines under AuCl₃ catalysis was then examined by Hashmi using quantum mechanical calculations coupled with deuterium experiments.³⁸²

Based on this promising initial data and the provision of mild reaction conditions, a number of groups were inspired to further explore gold catalysis for propargylamine cyclization to oxazoles. Verniest and Padwa carried out the cyclization of **713** using AuCl₃ to obtain oxazoles **714** in 59-77%. Interestingly, for **713** which has an additional alkyne present, a second cyclisation was observed on the oxazole. This *6-exo-dig* ring closure was facilitated by the presence of water. In fact, when aqueous acetonitrile was used, a 3:2 mixture of the desired oxazole **714** and cyclized product **715** was found. On the other hand, when anhydrous acetonitrile was used, only the oxazole **714** was formed in 77% yield (Scheme 144).³⁸³

Scheme 144. Gold catalyzed cyclization of propargylamides.

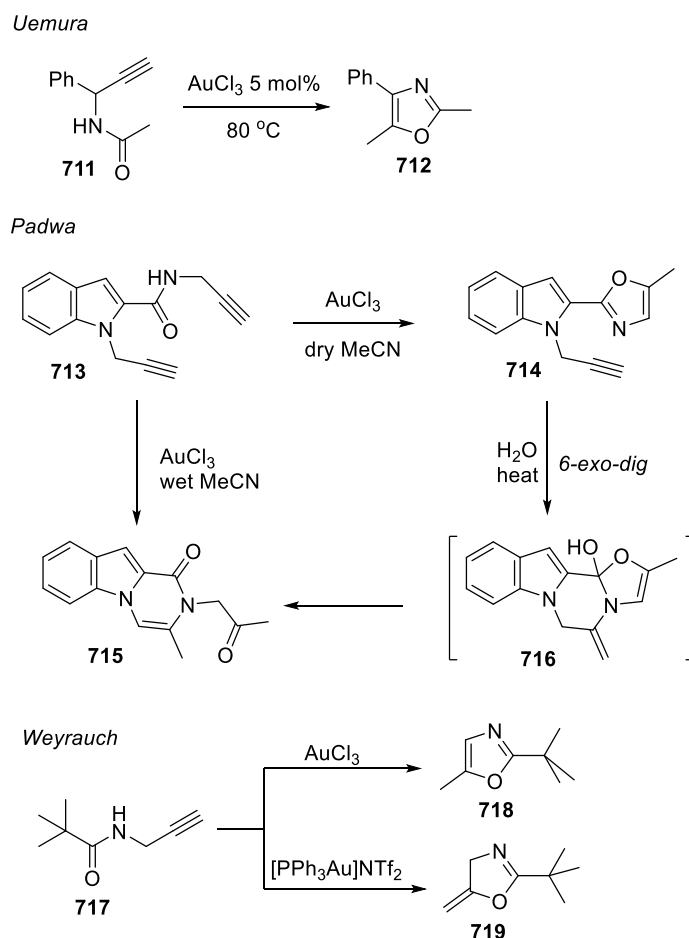

Additional examples of oxazole synthesis from propargylamides were reported by Weyrauch *et al.* who used different gold catalysts (AuCl_3 , $[\text{PPh}_3\text{Au}]\text{NTf}_2$, $[\text{PPh}_3\text{Au}]\text{OTs}$) to promote the cyclization reaction. Interestingly, the authors found that when the cyclization reaction was carried out with AuCl_3 , the oxazole ring **718** was formed as the only product, whilst in the presence of $[\text{PPh}_3\text{Au}]\text{NTf}_2$ or $[\text{PPh}_3\text{Au}]\text{OTs}$ the corresponding methylenedihydrooxazole **719** was obtained (Scheme 144).³⁸⁴

Tran-Dubé *et al.* looked into the use of Au(III) catalysts to develop a one-pot two-step reaction of propargylamines with acyl chlorides to yield tri-alkyl substituted oxazoles. The scope of the reaction was substantiated by reacting a variety of acid chlorides with propargylamines in the presence of Et_3N to first result in the *in situ* formation of

propargylamides. These latter then readily cyclized to yield the corresponding oxazoles following the addition of AuCl₃ at 45 °C.³⁸⁵

Propargylamides have also been converted into oxazoles *via* Au(III) catalysis, as recently reported by Timoshenko *et al.* in 2014³⁸⁶ and Shen *et al.* the following year.³⁸⁷

Au(I) catalysts were also used in the synthesis of oxazoles by a number of research groups. Curiously, in all cases, the formation of oxazole products was only successful when a silver co-catalyst (AgOTs,³⁸⁸ AgSbF₆³⁸⁹ or AgOTf³⁹⁰) was used. Mechanistic experiments on Au(I) catalyzed cyclizations showed that the gold catalysts only become activated when they are coordinated to silver to form bimetallic catalysts.³⁹¹

While silver has been found to be essential for Au(I) catalysis, it has also been found to be a valuable catalyst in its own right. Hu *et al.* found that AgBF₄ in toluene at 80 °C led to the conversion of a wide range of tosyl-protected *N*-propargylamides **720** into oxazoles **724**. Interestingly, the tosyl group is removed from the amide following the cyclization. A mechanism was hypothesized for this occurrence as shown in Scheme 145. Substrates where both R groups were aromatic resulted in moderate to good yields (53-90%), although alkyl groups such as methoxy, cyclopentyl or furanyl groups led to no conversion whatsoever.³⁹²

Scheme 145. Ag-catalyzed synthesis of oxazoles.

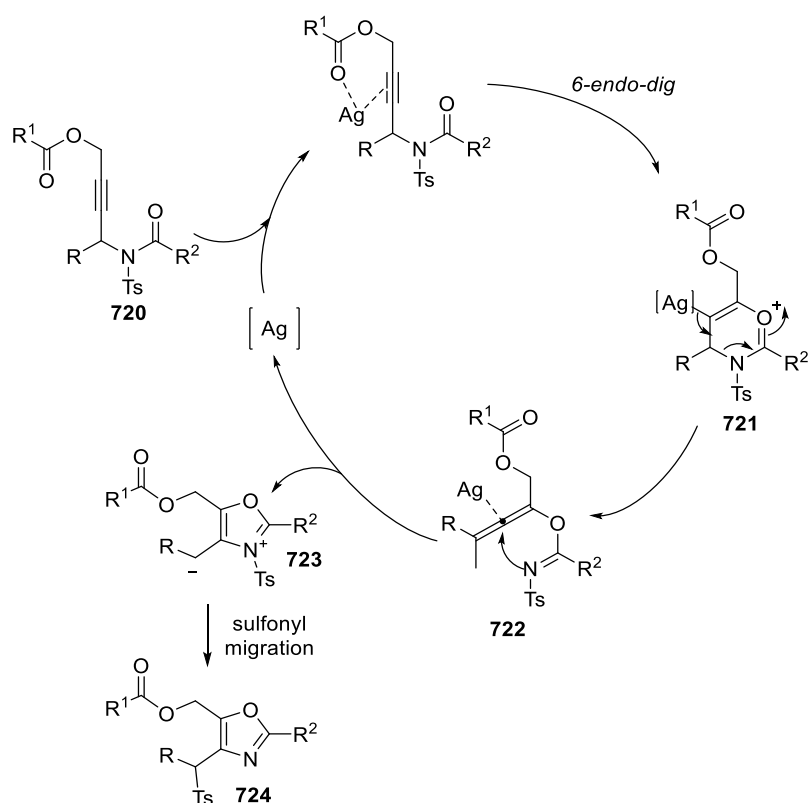

Zinc and iron have also found application as catalysts in the synthesis of oxazoles **729** and **733** from propargylamides **725**. Wang and coworkers treated **725** with both ZnI₂ and FeCl₃, finding that ZnI₂ tended to favor the cyclisation to oxazolines **729** in 75-97% yields whilst FeCl₃ led to the formation of the oxazoles **733** in 65-100% yields. They argued that, while both are Lewis acids, FeCl₃ is much stronger than ZnI₂, and therefore is able to coordinate to the amide as opposed to the alkyne. The authors proposed the reaction mechanism shown in Scheme 146.³⁹³

Scheme 146. Zn- and Fe-catalyzed synthesis of oxazolines and oxazoles

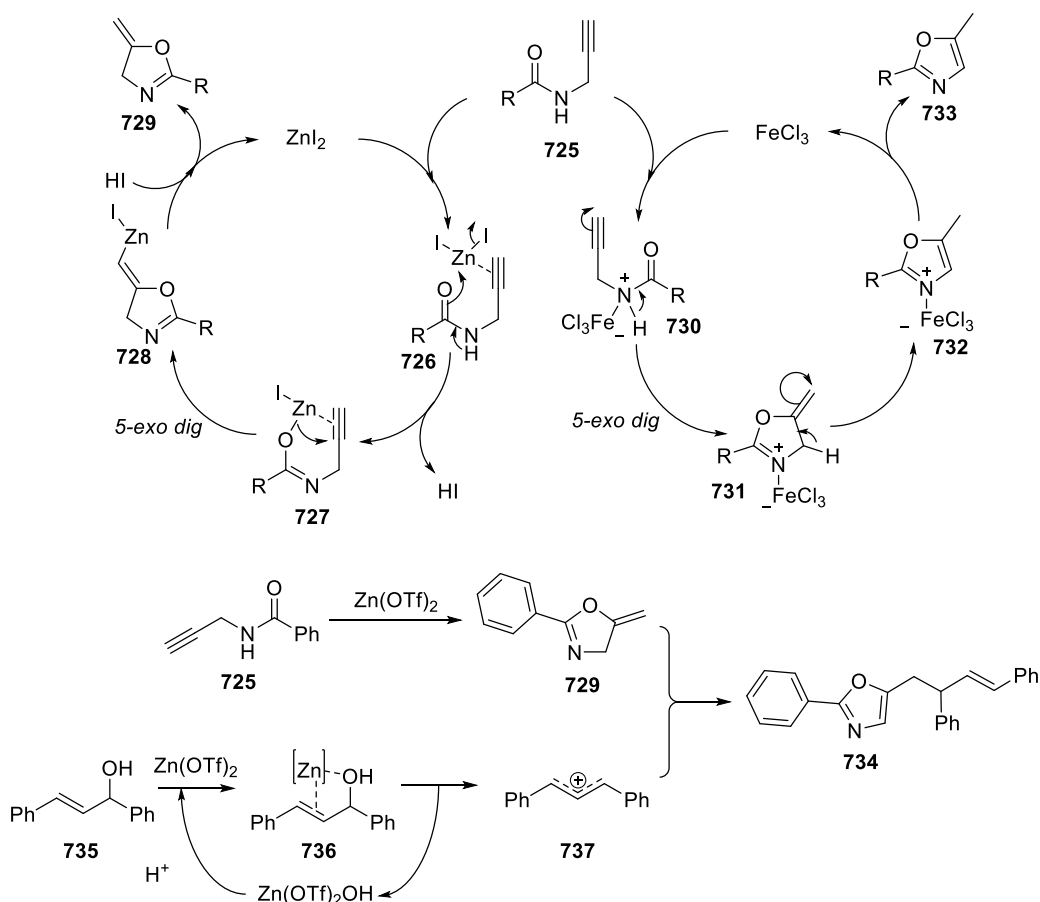

Xu's group then continued looking at Zn(II) as a cyclization mediator, in the form of $\text{Zn}(\text{OTf})_2$. The group found that $\text{Zn}(\text{OTf})_2$ was able to successfully catalyze the allylic alkylation of oxazoline **729** to yield oxazoles **734** in 47-94% yield. As shown in Scheme 146, $\text{Zn}(\text{OTf})_2$ is able to perform as the catalyst for both the cyclization and allylation processes. It was shown above that Zn(II) is only able to convert the propargylamide **725** into the oxazoline **729**. However, Zn(II) is also able to coordinate with the alkene and alcohol moiety of the allylic alcohol **735**, converting it into an allylcarbenium ion **737**. This reactive species then promptly couples with the oxazoline **729** to afford the alkynated oxazole **734**.³⁹⁴

Finally, an original approach to yield oxazoles by exploiting propargylamine substrates **738** was developed by Zhu and coworkers. In this case the propargylamine is not incorporated in the final oxazole backbone but acts as the synthetic equivalent of a vinyl cation. A possible

reaction mechanism for this transformation is reported in Scheme 147. It is clearly shown that the nitrogen of the propargylamide **738** is actually eliminated as an allylamine, and it is the nitrogen from the α -isocyanoacetamide **739** that forms the oxazole heteroatom. The authors also reported that Zn is known for forming complexes with oxazoles, and therefore argued that the catalyst was inactivated by the product formation. Thus, they used a stoichiometric amount of the catalyst, thereby reducing the environmental efficiency of the reaction.³⁹⁵

Scheme 147. Zn-promoted coupling of propargylamines with α -isocyanoacetamides.

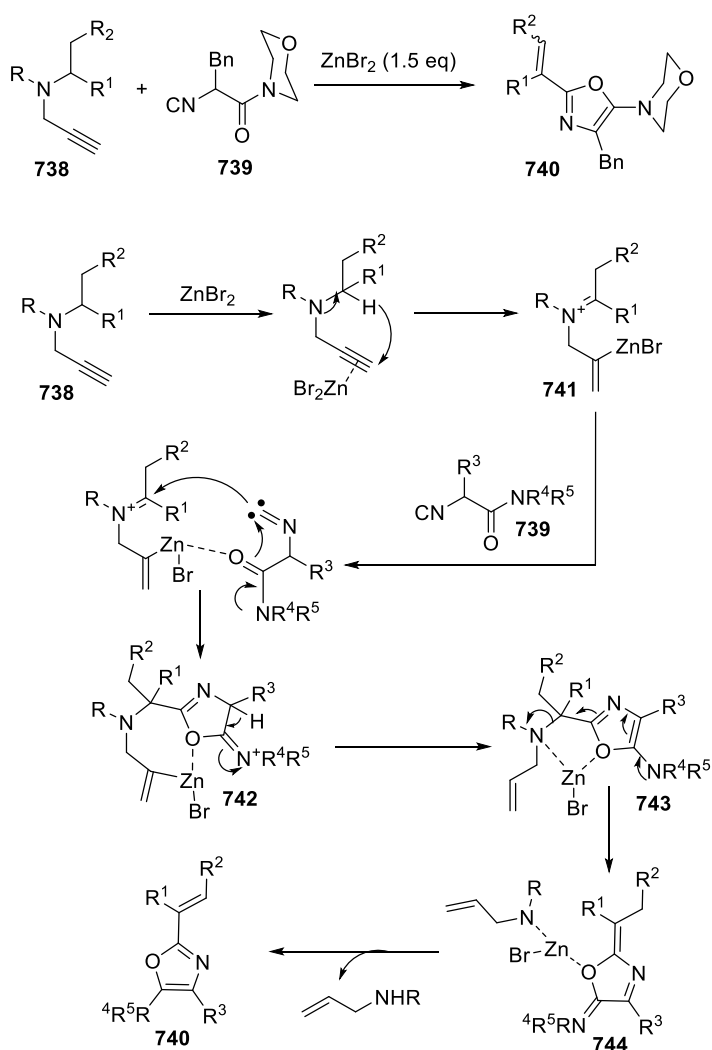

3.8.3 Various approaches for the synthesis of oxazoles. Lewis acids have been used to promote the cyclization of propargylamides and carbamates into oxazole or oxazoline

derivatives. Examples of using $B(C_6F_5)_3$ ³⁹⁶ or polyphosphoric acid (PPA)³⁹⁷ as Lewis acid mediators have been recently described by Melen and Vovk respectively.

Bartoli *et al.* found that stoichiometric amounts of $CeCl_3 \cdot 7H_2O$ was able to promote the conversion of propargylamides **745** into oxazoles **746**. The authors observed that **745** were converted in moderate yield into **746** when treated with $CeCl_3 \cdot 7H_2O$ and NaI and thus they further investigated and developed a more efficient method for this transformation. The most favorable conditions were found to be 1.3 equiv. of $CeCl_3 \cdot 7H_2O$, and 0.25 equiv. of NaI and I_2 respectively under microwave irradiation at 110 °C. Under these condition a set of oxazoles **746** was synthesized in good yields as summarized in Table 33.³⁹⁸

Table 33. $CeCl_3 \cdot 7H_2O$ mediated synthesis of oxazoles.

Reaction scheme: $R-C(=O)-NH-CH(R^1)-C\equiv C-R^2$ (745) $\xrightarrow[ACN, 110\ ^\circ C, MW\ 45\ min]{CeCl_3 \cdot 7H_2O, NaI, I_2}$ $R-C(=O)-N=C(R^1)-C(R^2)=O$ (746)

Entry	R	R ¹	R ²	Yield (%)
1	Me	COOEt	Ph	95
2	Ph	Ph	Ph	79
3	NHPh	Ph	Ph	30
4	2,4-Me ₂ -Ph	Me	H	75
5	Ph	H	H	91
6	4-CN-Ph	<i>i</i> Pr	H	93
7	CH ₃	H	COOEt	15

Dry silica gel has also surprisingly been highlighted as a cycloisomerization mediator, allowing the synthesis of oxazoles from propargylamides. There are a number of advantages

for the use of silica gel as a cycloisomerization agent such as the low cost and ease of removal.³⁹⁹

Saito *et al.* reported an interesting approach to cyclize propargylamides **747** using hypervalent iodine catalysts. Propargylamides **747** were treated with phenyliodine(III)diacetate (PIDA) in a range of solvents to ascertain the optimal conditions for their cyclization into oxazoles **753**. It was found that fluorinated alcohols, and HFIP in particular, were crucial for the synthesis of methyl acetylated oxazoles **753**. As a result, two methods were developed: the first comprised PIDA dissolved in AcOH at 90 °C, and the second was carried out with PIDA in HFIP and AcOH at room temperature. When developing the scope of the reaction, both methods were found to be efficient for the same substrates, although the first method received generally higher yields, perhaps on account of the higher temperature. The proposed mechanism is reported in Scheme 148. Two routes have been proposed depending on internal/terminal alkyne. In route A, the iodine(III) coordinates directly to the alkyne to promote nucleophilic attack from the amide leading to intermediate **749** which is then converted into the final oxazole by elimination of AcOH and PhI. In route B, the alkynyliodonium intermediate **750** is formed, leading then to the cyclization and formation of intermediate **749**.⁴⁰⁰

Scheme 148. PIDA-mediated cycloisomerization of propargylamides.

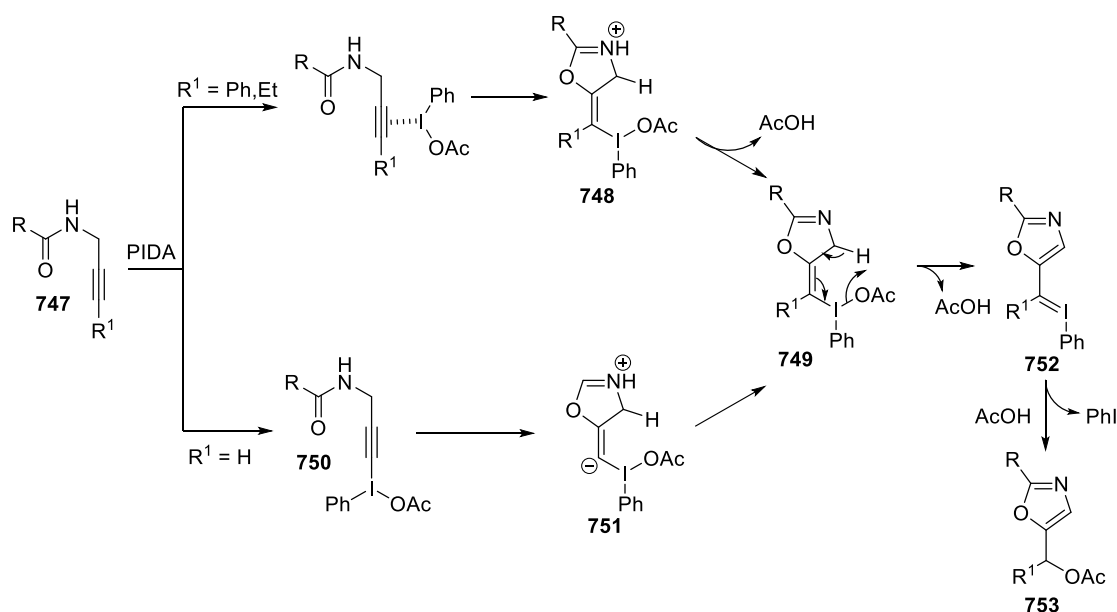

Recently, Wan and co-workers found that *N*-iodosuccinimide (NIS) was able to encourage a *5-exo-dig* intramolecular process of sulfonyl propargylamides **754** to yield oxazoles **757** following a reaction with molecular oxygen. Treatment of propargylamide **754** with NIS in DMF at room temperature yielded the oxazoline **756** which was subsequently reacted with oxygen at 80 °C in DCE to yield the oxazole **757** in a two-step one-pot process. Interestingly, when the same reaction was carried out in DCM at 40 °C the oxazolidine **755** was formed as the major product (Scheme 149).⁴⁰¹

Scheme 149. NIS-mediated cyclization of propargylamides.

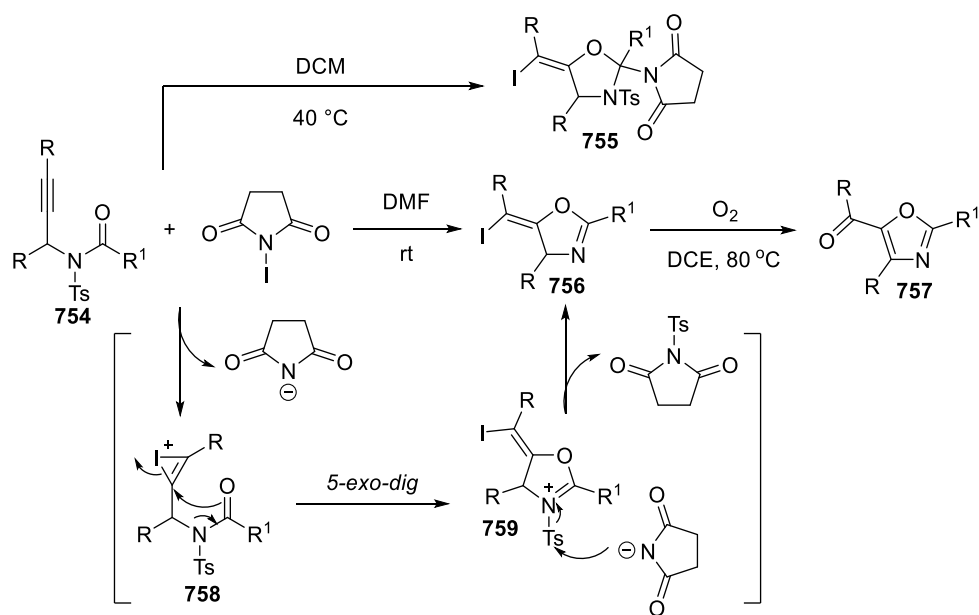

Van-Wachenfeldt *et al.* developed a facile method for the synthesis of oxazoles **762** from propargylamides under solvent free conditions. A number of substrates **760** were treated with different acyl chlorides under microwave irradiation, affording the corresponding oxazoles **762** in good yields in just 15 minutes (Table 34). The reaction works well with a wide range of substrates with the exception of only one substrate (*entry 7*) which bears a *p*-methoxyphenylmethylene group on the alkyne moiety. This is perhaps due to the methoxy group behaving as an electron donating group, which may interfere with the alkene's ability to stabilize the oxazole ring. The *N*-benzyl group on propargylamine **760** proved to be crucial for ensuring a high conversion to the oxazoles. It has been hypothesized that this is due to the *N*-Bn element stabilizing the cyclized intermediate, followed by trapping the Cl⁻ ion and producing BnCl as by-product.⁴⁰²

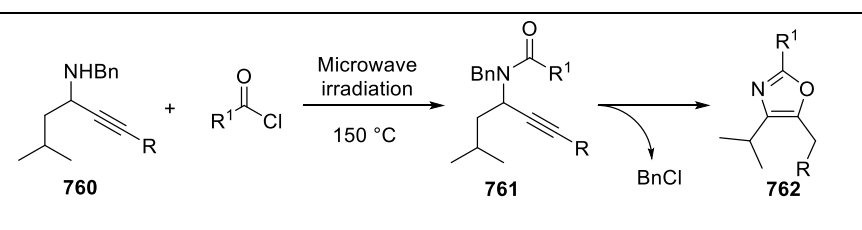
Table 34. Synthesis of oxazoles from *N*-benzyl propargylamines.

Entry	R	R ¹	Yield (%)
1	CH ₂ COOEt	Ph	99
2	CH ₂ Si(CH ₂) ₂ CH(CH ₃) ₃	Ph	81
3	Bn	Ph	84
4	CH ₃	Ph	80
5	Heptyl	Ph	68
6	4-NO ₂ -Ph-CH ₂	Ph	79
7	4-MeO-Ph-CH ₂	Ph	27
8	Bn	t-Bu	81
9	CH ₂ COOEt	Oxazole	64
10	CH ₂ COOEt	Thiophene	81
11	Bn	n-Bu	50
12	Bn	4-MeO-Ph	56

Another solvent free approach was reported in 2015 by Venkatesha *et al.* who described the synthesis of oxazoles from propargylamides using PDSA-treated Montmorillonite clay to promote the cyclization step.⁴⁰³

3.8.4 Synthesis of oxazolidinones. An interesting approach to synthesize oxazolidinones consists of the introduction of CO₂ into propargylamines. In 1996 Costa and co-workers reacted secondary propargylamines with CO₂ (1 bar) in the presence of various strong organic bases to yield oxazolidinones **763** in good to excellent yields. It was found that

secondary propargylamines ($R^2 \neq H$) had significantly lower yields, and that unsubstituted propargylamines ($R = R^1 = H$), required higher temperatures and pressures to proceed to completion (Scheme 150).⁴⁰⁴

Scheme 150. Synthesis of oxazolidinones *via* CO₂ insertion

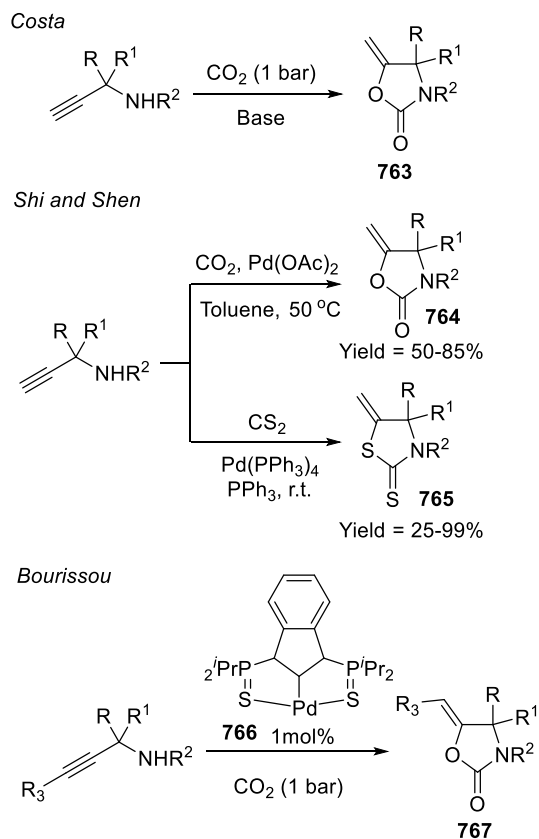

An update on this method showed that while pK_{BH^+} is a means of measuring the strength of bases, it is not the only factor at play in these cyclization reactions. In addition, sodium hydrogen carbonate was also used as a CO₂ carrier, which resulted in the best yields when combined with Bu₄NBr.⁴⁰⁵

Later, Shi and Shen showed that Pd(0) is an effective catalyst for the reaction of propargylamines with CO₂. Temperature, pressure, and ligand effect were explored, and it was found that Pd(OAc)₂ at 50 °C and 40kg/cm³ pressure gave the optimum conditions for the synthesis of oxazolidinones **764** from terminal propargylamines. During longer reaction times or elevated temperatures, they found that the corresponding imidazolidinones were

sometimes produced. This was hypothesized to be a result of the oxazolidinone reacting with surplus propargylamine, and confirmed by carrying out reactions between oxazolidinones and primary amines. Finally, the reaction of propargylamines with CS₂ and Pd(0) at room temperature was explored and the cyclic derivatives **765** were obtained in good yields (Scheme 150).⁴⁰⁶

More recently, Bourissou and co-workers described the synthesis of oxazolidinones **767** from propargylamines through CO₂ insertion using indenediide-based Pd SCS pincer complexes **766** as catalysts. A series of 2-oxazolidinones was synthesized in 71-98% yields under mild conditions (0.5–1 bar of CO₂, DMSO, 40–80 °C, 1–5 mol% Pd loading). The indenediide Pd complex **766** proved to be efficient for a wide range of propargylamine substrates, including challenging substrates such as secondary propargylamines bearing tertiary alkyl groups on the nitrogen, primary propargylamines, and propargylanilines.⁴⁰⁷ Yoshida *et al.* reported a similar approach to access oxazolidinones using 2 mol% of AgOAc as catalyst to promote the CO₂ insertion into propargylamines,⁴⁰⁸ whilst a gold catalyzed method with AuCl(IPr) has been described recently by Hase *et al.*⁴⁰⁹ The mechanistic details for the gold catalyzed reaction were elucidated by Yuan and Li using DFT calculations and are shown in Scheme 151.⁴¹⁰ The calculations indicate that the reaction starts with an *N*-coordinated species **769**, which undergoes isomerization to give an alkyne-coordinated species **770**. A second propargylamine inserts between the chloride anion and the alkyne-coordinated complex. Then insertion of CO₂ leads to the carbamate intermediate **773**. Finally, ring formation occurs leading to **774** which, after protonation and release of the Au catalyst, gives the expected five-membered-ring oxazolidinone **775**.

Scheme 151. Au-catalyzed synthesis of oxazolidinones

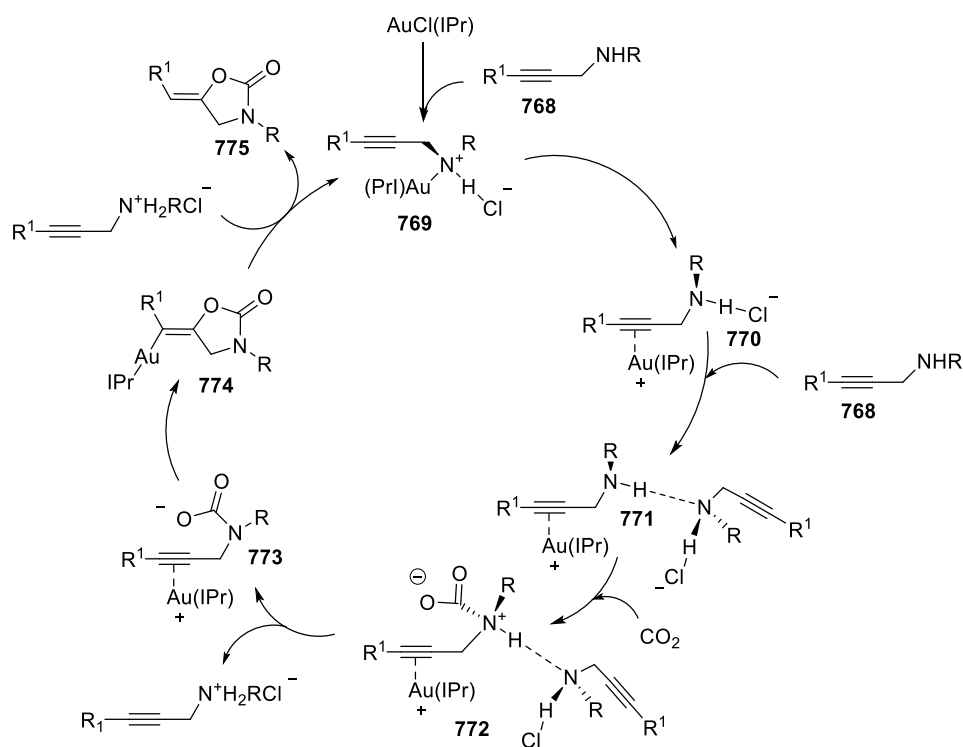

Very recently, Fujita *et al.* reported a similar approach to access oxazolidinones. The authors described the carboxylative cyclization of propargylamines with CO₂ catalyzed by dendritic *N*-heterocyclic carbene–Au(I) complexes.⁴¹¹ Similarly, He and co-workers described the incorporation of CO₂ to propargylamines by Cu(II)-substituted polyoxometalate-based ionic liquids to yield 2-oxazolidinones⁴¹² as well as by *in-situ* generated Zn(II) catalyst.⁴¹³ Nevado's group described an interesting synthesis of oxazolidinones through a one-pot Sonogashira-carboxylative coupled reaction. Aryl iodides and propargylamines were treated with [PdCl₂(dppf)] and CuI as catalysts and DABCO as a base in the presence of CO₂ (0.5-1 atm) leading to the formation of oxazolidinones **776** with 41-95% yields. The CuI is involved in the Sonogashira reaction as shown in the Scheme 152 whilst the palladium catalyst has a double role, facilitating both the Sonogashira coupling and formation of intermediate **777** as well as the cyclization step to occur.⁴¹⁴

Scheme 152. Pd-catalyzed incorporation of CO₂ into propargylamines.

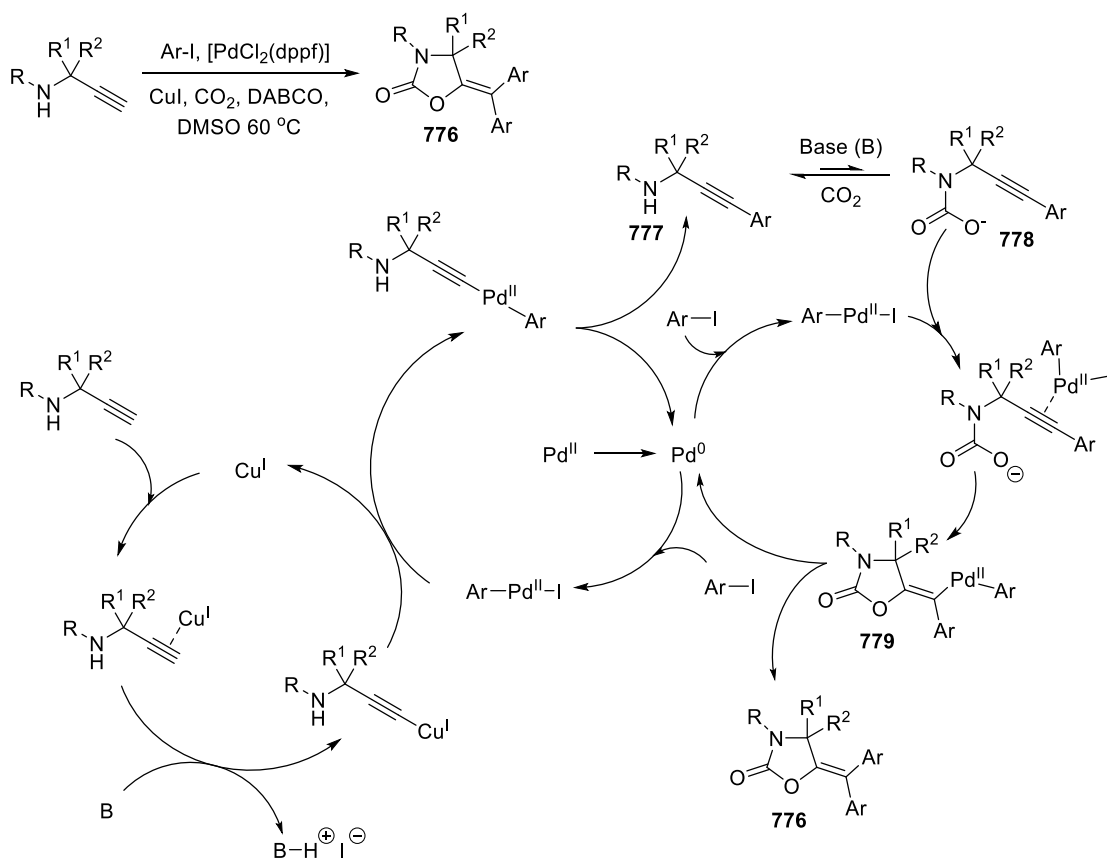

Finally, it is worth noting the metal- and base-free approach to oxazolidinones reported by Ikariya and co-workers. The authors found that propargylamines react smoothly with CO₂ under supercritical conditions to selectively give a variety of (*Z*)-5-alkylidene-1,3-oxazolidin-2-ones even in the absence of any metal or base catalyst.⁴¹⁵

3.8.5 Synthesis of isoxazoles from propargylamines. Isoxazoles are regioisomers to oxazoles with the key distinction that the nitrogen is located in a 1,2-position to the oxygen instead of 1,3-position. The isoxazoles can be generally formed through a 1,3-dipolar cycloaddition of a nitrile oxide on a triple bond. Thus, any propargylamine can be in principle converted into an aminomethyl-isoxazole as shown in Scheme 153. Basolo *et al.* synthesized a series of oxazoles **781** in excellent (81-95%) yields as precursors in the synthesis of polyheterocyclic systems⁴¹⁶ whilst Yermolina *et al.* obtained a small library of isoxazole compounds **783** in 12-69% yields through the reaction of propargylamine **782** and nitrile

oxides using $\text{CuSO}_4 \cdot 5\text{H}_2\text{O}$ and copper powder as catalytic system.⁴¹⁷ Similarly, Babulreddy *et al.* reported the synthesis of isoxazoles **785** under comparable reaction conditions.⁴¹⁸

Scheme 153. Synthesis of isoxazoles from propargylamines.

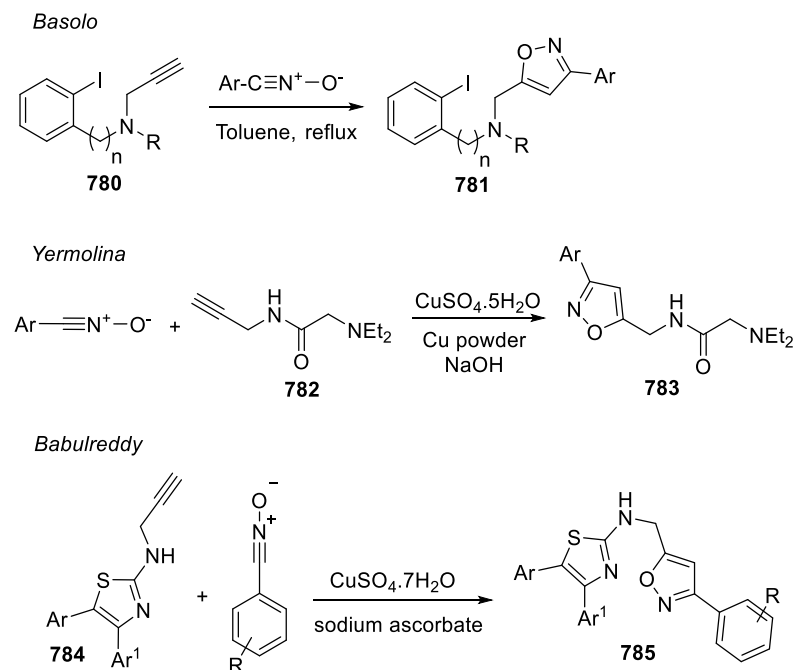

A noteworthy approach to access isoxazolines has been described by Campagne and co-workers who found that protected *N*-hydroxyl-propargylamines **786** could be converted into **787** by treatment with $\text{NaAuCl}_4 \cdot 2\text{H}_2\text{O}$ in the presence of DMAP as co-catalyst. A wide range of isoxazolines **787** were synthesized in good yields (38-86%).⁴¹⁹ Interestingly, the same authors showed earlier that the treatment of the hydroxylamine **788** with Et_3N in refluxing DCM can lead directly to the isoxazole **789** in 86% yield as shown in Scheme 154.⁴²⁰

Scheme 154. Cyclization of *N*-hydroxyl-propargylamines into isoxazoles and isoxazoles.

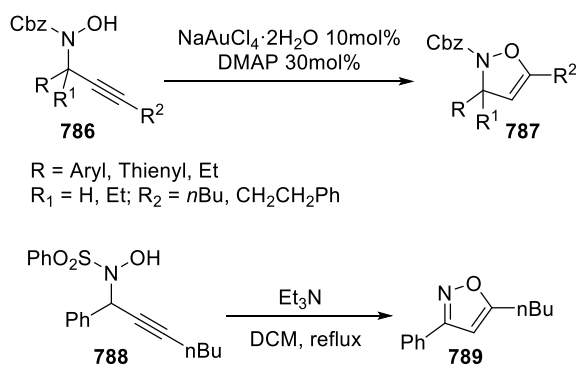

3.9 Synthesis of thiazoles and thiazolines from propargylamines

Thiazoles and thiazolines are a class of organic compounds closely related to oxazoles and oxazolines with broad application in organic and medicinal chemistry. Different methods to synthesize these compounds from propargylamines have been described in the literature.

3.9.1 Reactions of propargylamines with CS₂. The first instance of propargylamine cyclization to a thiazole derivative was carried out in 1949 by Batty and Weedon. The authors tried to combine a propargylamine with CS₂ with the aim to prepare a thiocarbamate derivatives. However, instead of the expected product, they found that a thiazolidine-thione **792** was produced in 58% yield. The authors also discovered that addition of cold sulfuric acid to this compound resulted in the conversion of **792** into a thiazole-thione derivative **793** (Scheme 155).⁴²¹

Scheme 155. Cyclization of propargylamine into thiazolidine-thione

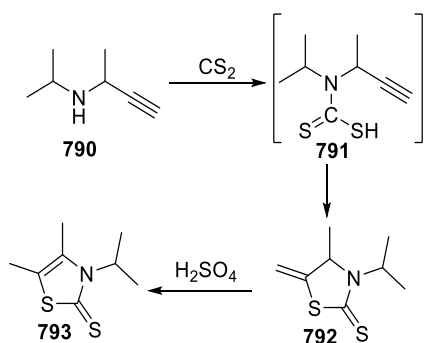

Later, in 1985, Hanefield and Bercin rediscovered this method to obtain thiazolidine-2-thione derivatives through the addition of CS₂ to propargylamine and subsequent cyclisation.⁴²² More recently, the reaction of propargylamines with CS₂ has been revisited by Shi and Shen.⁴⁰⁶ The authors observed that the cyclization of propargylamines **794** into **795** with CS₂ could be facilitated by a Pd(0) catalyst, namely Pd(PPh₃)₄. Compared to Hanefield and Bercin's work, they found that the yield of the reaction could be increased up to 99% (Table 35). However, the presence of either a secondary amine or substitutions in the R-position reduced the yields dramatically.

Table 35. Reaction of propargylamines with CS₂.

Entry	R	R ¹	Catalyst	Yield (%)
1	H	H	NaOH	45
2	H	H	Pd(PPh ₃) ₄	99
3	Et	H	Pd(OAc) ₂	40
4	H	Bn	Pd(OAc) ₂	25

Stevens and co-workers described a two step synthesis of dihydrothiazoles. The authors reacted commercial propargylamine with CS₂ and allylbromide affording *N*-propargylic dithiocarboimidates which were then converted into dihydrothiazoles through a AuCl₃ catalyzed 5-*exo-dig* cyclization and 1,3-alkyl migration.⁴²³

A metal-free approach to thiazole derivatives **797** and **800** has been described by Balova⁴²⁴ and Shafiee respectively.⁴²⁵ Both research groups reacted aromatic propargylamides **799** or aromatic propargylamines **796** with CS₂ in the presence of KOH as a base. Two new thiazole-heterocycles **797** and **800** were obtained in few hours in moderate to excellent yields (45-85%), as shown in Scheme 156.

Scheme 156. Base catalyzed reaction of propargylamines with CS₂.

Balova

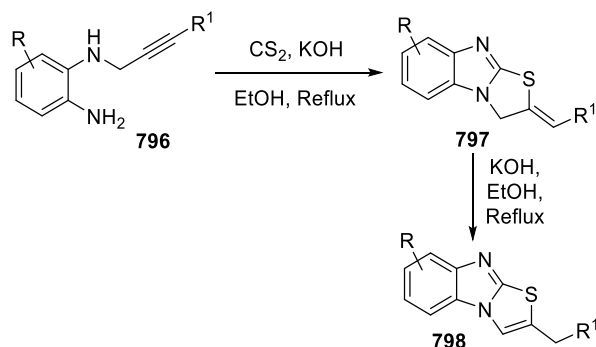

Shafiee

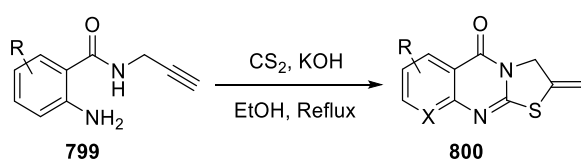

Very recently, Van der Eycken reported an elegant one-pot process to synthesize thiazolidine-2-thiones **802** through a multicomponent approach. The authors combined a copper catalyzed A³ coupling reaction of aldehydes, amines and alkynes with CS₂ incorporation, leading to **802** in good yields (26-73%). The A³ coupling in the presence of CuBr leads to the formation of the propargylamine intermediate **801** which immediately reacts with CS₂ leading to the cyclization and formation of **802** in one-pot (Scheme 157).⁴²⁶

Scheme 157. A³ coupling - CS₂ insertion cascade.

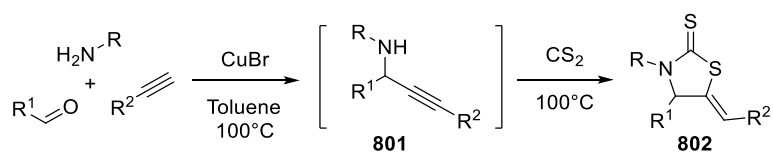

3.9.2 Reactions of propargylamines with isothiocyanates. To avoid the use of toxic CS₂ in the synthesis of thiazole and thiazoline derivatives, isothiocyanates can be used instead. These latter reagents can be easily coupled with propargylamines leading to thiazole derivatives in a single step. Easton *et al.* carried out the first research into the reaction of substituted propargylamines **803** with isothiocyanates to yield 2-iminothiazolidines **804**. The reaction was carried out in diethyl ether, in the absence of catalyst and led to the desired products **804** in quantitative yields. It is worth mentioning that while it was possible to isolate a non-cyclized thiourea intermediate from primary propargylamines, the thiourea intermediates arising from the reactions of isothiocyanates with secondary propargylamines were much less stable and cyclized more readily to yield iminothiazolidines **804**. Additionally, it was found that this cyclization could be augmented just through heating, thereby making the thiourea difficult to sequester from the reaction mixture (Scheme 158).⁴²⁷

Scheme 158. Reaction of propargylamines with isothiocyanates.

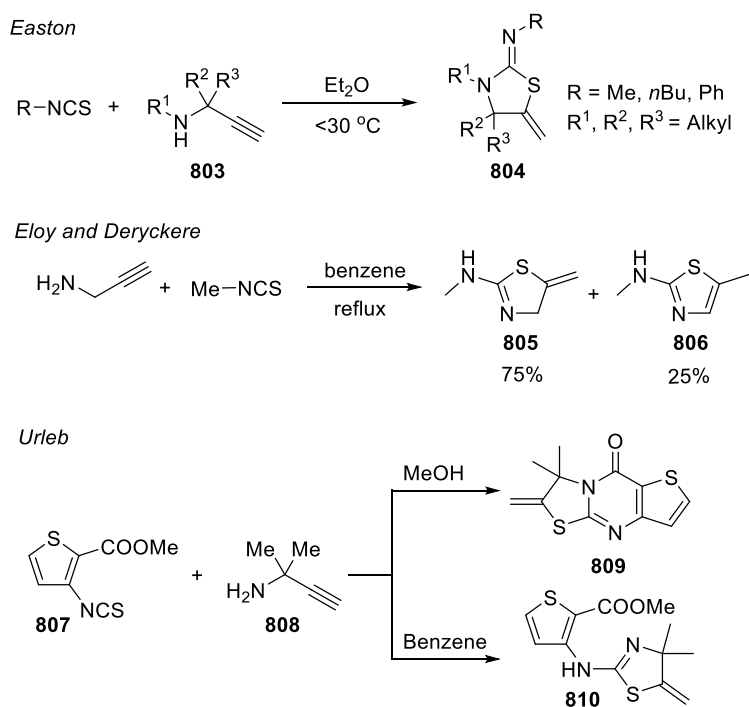

Some years later, Eloy and Deryckere followed on from this work. Their method involved mixing commercial propargylamine with methyl-isothiocyanate in refluxing benzene to yield a mixture of a 2-aminothiazoline **805** and an aminothiazole **806** in a 3:1 ratio.⁴²⁸ In 1993, Urleb also investigated this reaction, reacting a substituted propargylamine **808** with isothiocyanate **807**. Interestingly, when these reagents were heated together in methanol thiazolothienopyrimidinone **809** was obtained as product whilst when heated in benzene a 2-aminothiazoline **810** product was obtained in 65% yield (Scheme 158).⁴²⁹

An interesting work by Pieters and co-workers described the coupling of propargylamine compounds with lactose- β -isothiocyanates to produce 2-aminothiazoline protein-carbohydrate ligands **812** able to bind with the cholera toxin to potentially prevent the onset of the disease. In their synthetic method, a Boc-protected propargylamine was first deprotected using TFA, and then lactose β -isothiocyanate and DIPEA were added, resulting in the cyclized 2-aminothiazoline **812** in 84% yield. The lactose hydroxide groups were supposedly hydrolyzed by the silica gel and reconverted into acetyl groups using acetic acid.

The authors remarked that the 2-aminothiazoline **812** remained stable at ambient temperature, without converting to the thiazole, and also proved to have high affinity with the cholera toxin target (Scheme 159).⁴³⁰

Scheme 159. Synthesis of lactose-2-aminothiazoline conjugate **812.**

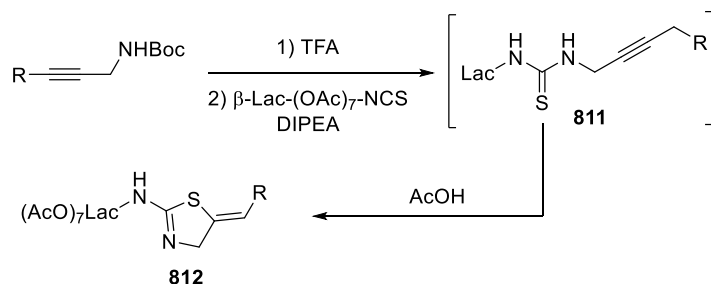

Later, Samsal *et al.* developed the synthesis of 2-aminothiazoles by treatment of propargylamine salts with different isothiocyanates and trimethylamine. Desired 2-aminothiazoles were obtained in good to excellent yields (65-93%) in 12-24 hours.⁴³¹

Other approaches to synthesize thiazolines through the use of isothiocyanates include the work of Zhou and co-workers, who investigated the three-component halocyclization of *N*-propargylamines, aryl isothiocyanates and iodine,⁴³² the work of Madaan *et al.* who described a one pot-two step A³ coupling reaction of alkynes, aldehydes and alkynes in the presence of isothiocyanates,⁴³³ and the work of Castillo-Gomez and coworkers who recently described the synthesis of benzoylamido-substituted thiazoles and thiazolidines through the reaction of acid chlorides, ammonium isothiocyanate and substituted propargylamines in the presence of Et₃N.⁴³⁴ An interesting “green” approach to thiazolidines from primary and secondary propargylamines and fluorescein isothiocyanates was described by Clausen and co-workers (Scheme 160). The fluorescein-thiazolidines **813** were obtained under mild conditions (20 °C, water and tert-butanol) with excellent yields (78-81%). The reaction progress was also monitored, and it was found that a mixture of thiourea and thiazolidine (2:3 ratio) intermediates were formed after 3 hours, but after 24 hours only the thiazolidine products remained, implying a successive two-step reaction mechanism.⁴³⁵

Scheme 160. Synthesis of thiazolidines **813** and **816**.

Clausen

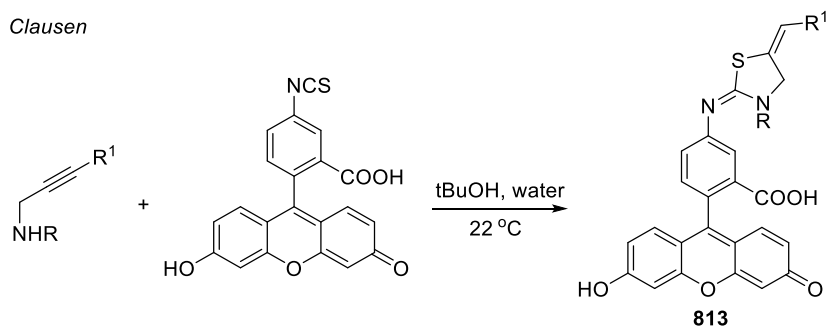

Beauchemin

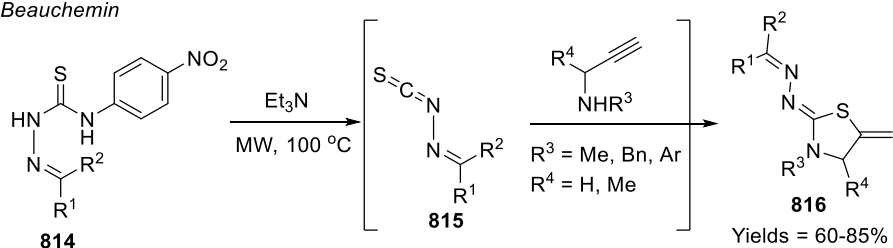

Finally, Beauchemin and co-workers reported the syntheses of a series of substituted thiazolidines **816** using *N*-isothiocyanate precursors **814**. Treatment of **814** with a base (Et₃N) under microwave irradiation led to the formation of the isothiocyanate intermediate **815** which in turn reacts with propargylamines to afford thiazolidines **816** in good yields.⁴³⁶

More recently, our research group developed a microwave assisted method by which it was possible to selectively synthesize 2-aminothiazoles **817** and/or 5-methylthiazol-2-amines **818**. Table 36. This paper represents an extension of a previous method, discovered during the synthesis of novel anti-HIV agents, for the selective synthesis of 2-aminothiazoles and 5H-thiazolo[3,2-a]pyrimidin-5-ones.⁴³⁷⁻⁴³⁸ We found that, when propargylamines were reacted with isocyanates in DCE under microwave irradiation at 130 °C, the thiazole **817** was formed as the only reaction product in good to excellent yields (*entries 1-3*). On the other hand, when the same reaction was carried out in CH₃CN at 100 °C the thiazoline **818** was obtained as the main reaction product (*entries 4-6*). In some cases, where R = aryl substituted group, the reaction mixture had to be heated at 160 °C to allow the selective formation of the corresponding thiazole **817** (*entries 10 and 12*), as outlined in Table 36. On the other hand,

when R = Ar, the thiazoline **818** was obtained as main product when the reaction was carried out in DCE at 130 °C (*entry 11*). Interestingly, it was found that if a phenyl group was bound to the alkyne, regardless of temperature or solvent, only imidazolethiones **819** were obtained (Scheme 161).⁴³⁹ An imidazolethione intermediate **821** is supposed to be formed and react then with another molecule of isothiocyanate to afford the final product **819**.

Table 36. Microwave-assisted reactions of propargylamines with isothiocyanates.

Entry	R	R ¹	Solvent	Temp.	Product ratio
				(°C)	817/818
1	H	Allyl	DCE	130	100/0
2	H	Ph	DCE	130	100/0
3	H	Bn	DCE	130	100/0
4	H	Allyl	CH ₃ CN	100	0/100
5	H	Ph	CH ₃ CN	100	20/80
6	H	Bn	CH ₃ CN	100	25/75
7	Ph	Allyl	DCE	130	100/0
8	Ph	Allyl	CH ₃ CN	100	32/68
9	4-Cl-Ph	Allyl	DCE	130	50/50
10	4-Cl-Ph	Allyl	DMF	160	100/0
11	2,4-Cl-Ph	Allyl	DCE	130	0/100
12	2,4-Cl-Ph	Allyl	DMF	160	100/0

Scheme 161. Mechanism of formation of 819.

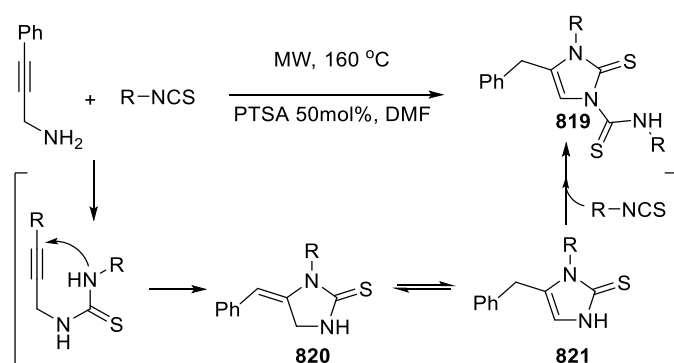

3.9.3 Synthesis of thiazoles/thiazolines from *N*-propargyl thioamides. Propargylamines can be converted into *N*-propargyl thioamides, which can in turn be cyclized to afford thiazole and thiazoline derivatives. Short and Ziegler first described the cyclization of *N*-propargyl thiocarbamates into disubstituted thiazoles through an addition–cycloelimination strategy with sodium benzenesulfinate and I_2 in ethyl acetate and water at 80 °C.⁴⁴⁰ In 1998, Wipf and co-workers converted propargylamines **822** into corresponding thiazolines **824** through reaction with dithioic acids in the presence of EDCI in DCM. Further treatment of thiazoline **824** with DBU at 0 °C provided thiazoles **825** in good yields (Scheme 162).³⁷² A similar approach was later reported by Chandrasekharam *et al.*⁴⁴¹

Scheme 162. Reaction of propargylamines with dithioic acids.

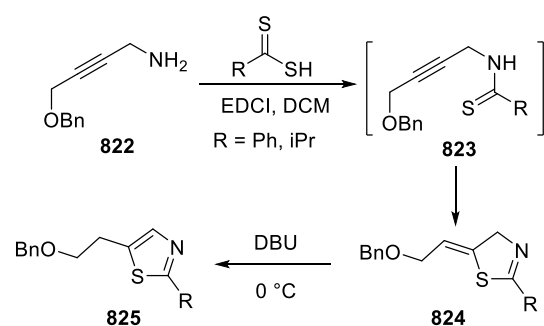

Sasmal *et al.* also developed a one-pot synthesis of thiazoles **830** from silyl protected propargylamines **826**. These latter were treated with benzotriazole protected thioacetic compounds, which yielded a thioamide intermediate **828** through *N*-desilylation and thioacylation. Cyclization is promoted by the addition of triethylamine to yield a

dihydrothiazole intermediate **829**. Finally, isomerization is facilitated by intramolecular Michael addition which results in the desired thiazole **830**. The reactions took place at room temperature, and led to a series of derivatives in 26-93% yields (Scheme 163).⁴⁴²

Scheme 163. Synthesis of thiazoles via an intramolecular thio-Michael strategy.

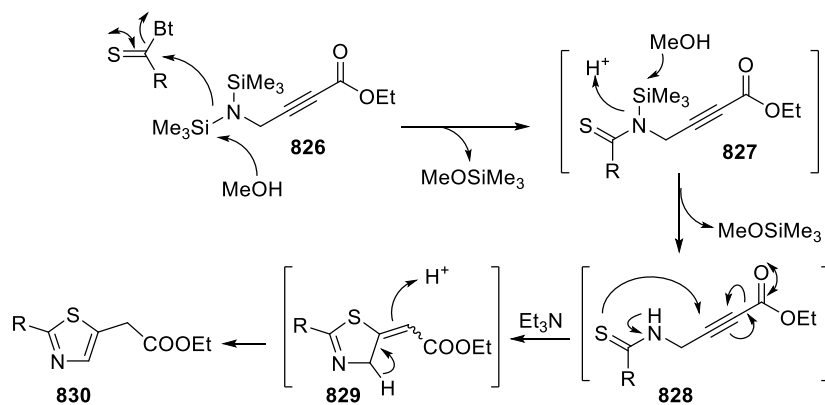

Yarovenko *et al.* reported the synthesis of thiazoles **832** through the reaction of monothioamides **831** in the presence of bromine. The authors' highlighted the importance of solvent choice for the outcome of the reaction, with DCM giving yields of 50-55%, while reduced yields of 30-35% were found when the reaction was carried out in methanol. Finally, it was found that carrying out the reaction in the ionic solvent BMIM-PF₆ led to thiazoles **832** in 83-87% yields. The proposed reaction mechanism is illustrated in Scheme 164. Initially, bromine coordinates the alkyne to form a bromonium ion intermediate **833**. A 5-*exo-dig* cyclization occurs to yield a dihydrothiazole **834**. Then, a second bromine molecule reacts with the alkene to form the dibromomethyl thiazole **832**.⁴⁴³

Scheme 164. Synthesis of thiazoles from monothiooxamides.

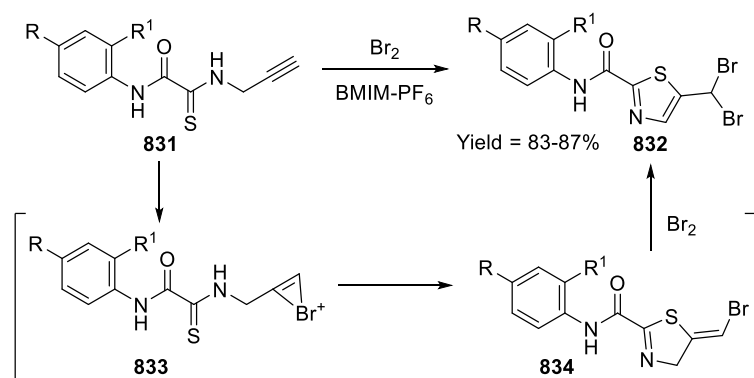

Two interesting approaches have been developed by Maddani and Prabhu, who reported the synthesis of a 5-methylenethiazolidine-2-thione by treatment of commercial propargylamine with molybdenum xanthate ($\text{MoO}_2(\text{S}_2\text{CNMe}_2)_2$),⁴⁴⁴ and by Meng and Kim, who described the synthesis of a thiazolidine derivative **835** from a *N*-propargylthiocarbamate through a W- and Mo-catalyzed *5-exo-dig* cyclization reaction under irradiation at 350 nm.⁴⁴⁵ Recently, Alhalib and Moran described the cyclization of *N*-propargylamides to synthesize substituted dihydrothiazoles **836**. The *N*-propargylamides were converted into the corresponding thiamides by treatment with Lawesson's reagent in toluene, and in turn subjected to a *5-exo-dig* cyclization to afford the desired dihydrothiazoles as depicted in Scheme 165.⁴⁴⁶ Interestingly, both methods can also be used for the synthesis of oxazole derivatives.

Scheme 165. Synthesis of thiazolidine **835** and **836**.

Meng and Kim

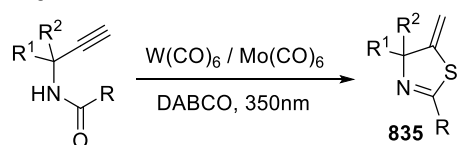

Alhalib and Moran

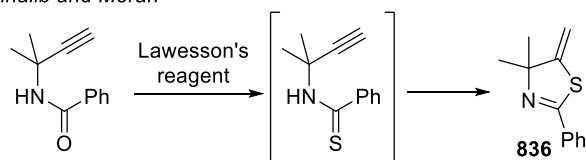

Finally, the approach of the Čikotienė's group is noteworthy who described the synthesis of thiazoline derivatives through the cyclization of propargylthioureas with NBS.⁴⁴⁷

3.10 Synthesis of imidazoles from propargylamines.

Several examples of synthesizing imidazole and imidazole derivatives from propargylamines have been described in the recent literature. A very early synthesis of imidazoles from propargylamines was reported in 1974. Propargylamines were reacted with acetamidic esters to afford propargylamidine intermediates which favorably cyclized to give imidazoles.⁴⁴⁸ In general, the conversion of a propargylamine into an amidine derivative is an essential step for the synthesis of imidazoles. However, recently, some different approaches have been described. Propargylamidines can be prepared and isolated through different methods or can be generated *in situ* through the reaction of imino(thio)ethers with propargylamines and then cyclized into imidazoles. Imidazole containing polycyclic compounds have been synthesized by treatment of appropriate scaffolds with propargylamines under relatively mild conditions. Benzodiazepines **837** were combined with propargylamine in PTSA to yield imidazole containing compounds **838** in good yields⁴⁴⁹ whilst iminoether **839** was reacted with propargylamine in toluene to yield derivative **840**.⁴⁵⁰ Scheme 166.

Scheme 166. Reaction of imino(thio)ethers and benzothiazine-thiones with propargylamines.

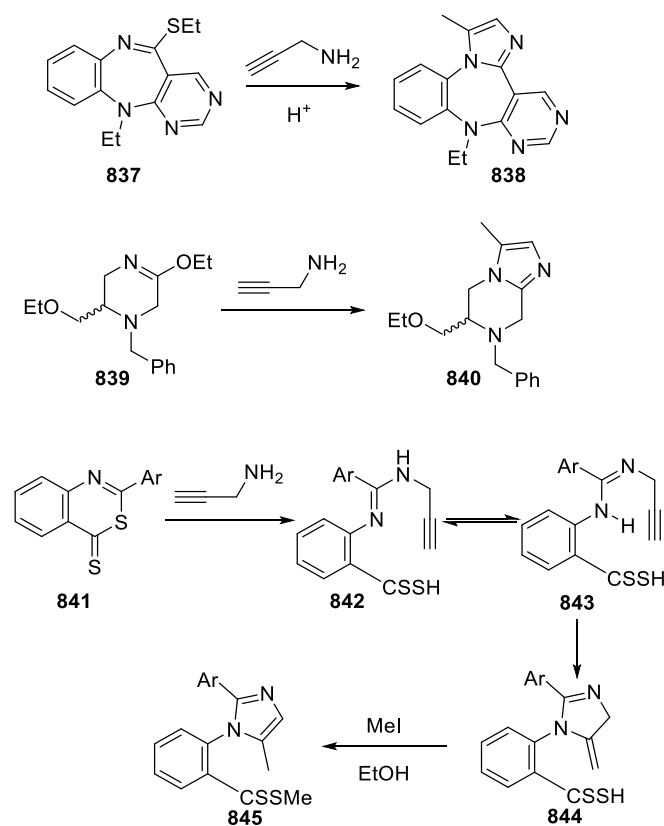

An earlier approach to *N*-aryl-imidazoles was described by Molina *et al.* who found, during their studies on the synthesis of quinzazolines from benzothiazine-thiones, that the reaction of propargylamine with **841** led to the synthesis of imidazole **845**.⁴⁵¹ The reaction proceeds through the formation of a propargylimidine intermediate **842** which in turn cyclizes to afford imidazole **845** as shown in Scheme 166.

An interesting multicomponent approach to imidazoles was developed by Gracias *et al.* in 2005 who reported the van-Leusen coupling reaction of a tosylmethyl isocyanide (TosMIC) with an aldehyde and a propargylamine. The imidazole derivatives **846** were obtained with 43-60% yields. This process was coupled with intramolecular alkyne-azide cycloaddition to produce compounds **847**.⁴⁵² A similar imidazole derivative **848** was recently synthesized by

Nguyen *et al.* through a one-pot assembly of a diketone, an aldehyde and a propargylamine in the presence of InCl_3 as catalyst.⁴⁵³ Scheme 167.

Scheme 167. Multicomponent synthesis of imidazoles.

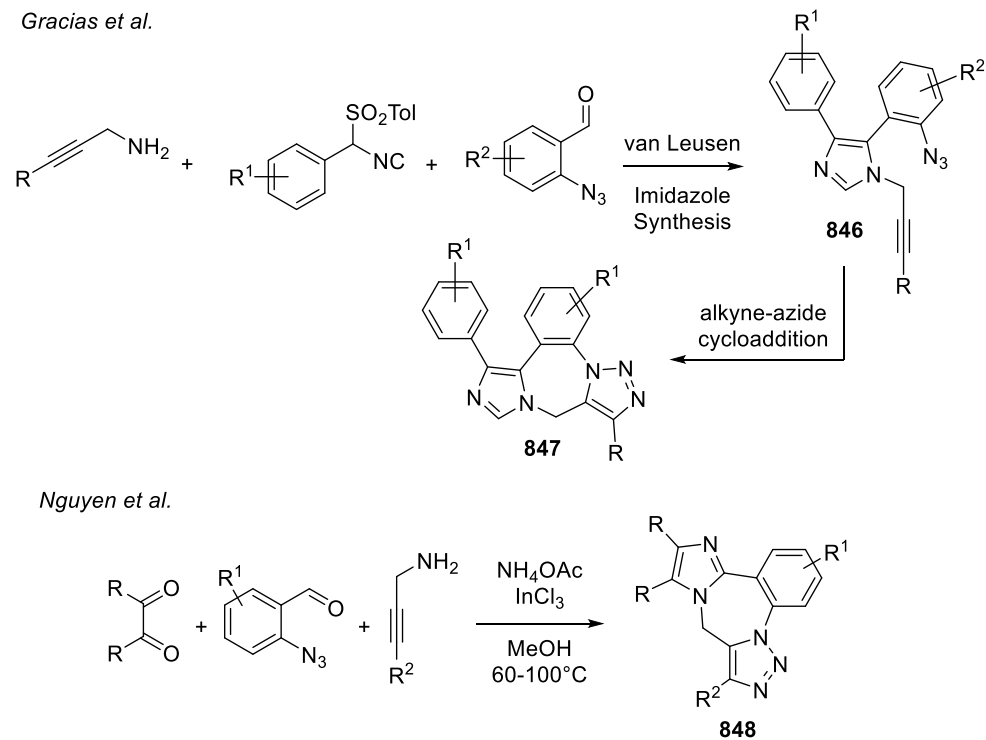

An easy approach for the synthesis of imidazoles has been described by Tice and Bryman, who reported the cyclization of the propargylamidine **850**, in turn obtained from **849** by treatment with propargylamine, into the imidazole **851**. Interestingly, the formation of the imidazole **853** was also observed, probably due to the reaction of propargylamidine **850** with surplus propargylamine.⁴⁵⁴ Scheme 168. This reaction was further developed some years later by Sosa who investigated the effect of different acids on the rate of each of these imidazole product formations.⁴⁵⁵

Scheme 168. Cyclization of propargylamidines.

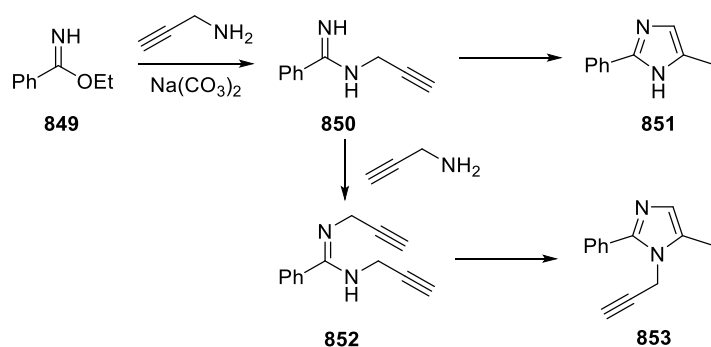

In 2007, Abbiati *et al.* developed an interesting method to synthesize imidazoles **854** from propargylamidines by treatment with aryl-halides in the presence of $\text{Pd}(\text{PPh}_3)_4$ and CuI . Two different reaction pathways have been proposed. Route B is a standard Sonogashira reaction that led to intermediate **859** which cyclized to afford the imidazole **854**. Route A occurs without the involvement of CuI and through the formation of a Pd-alkyne complex. However, the reaction was very slow in the absence of a copper salt and thus neither of the two pathways can be excluded, even if the Route A seems the most likely (Scheme 169).⁴⁵⁶

Scheme 169. Synthesis of imidazole via Sonogashira reaction.

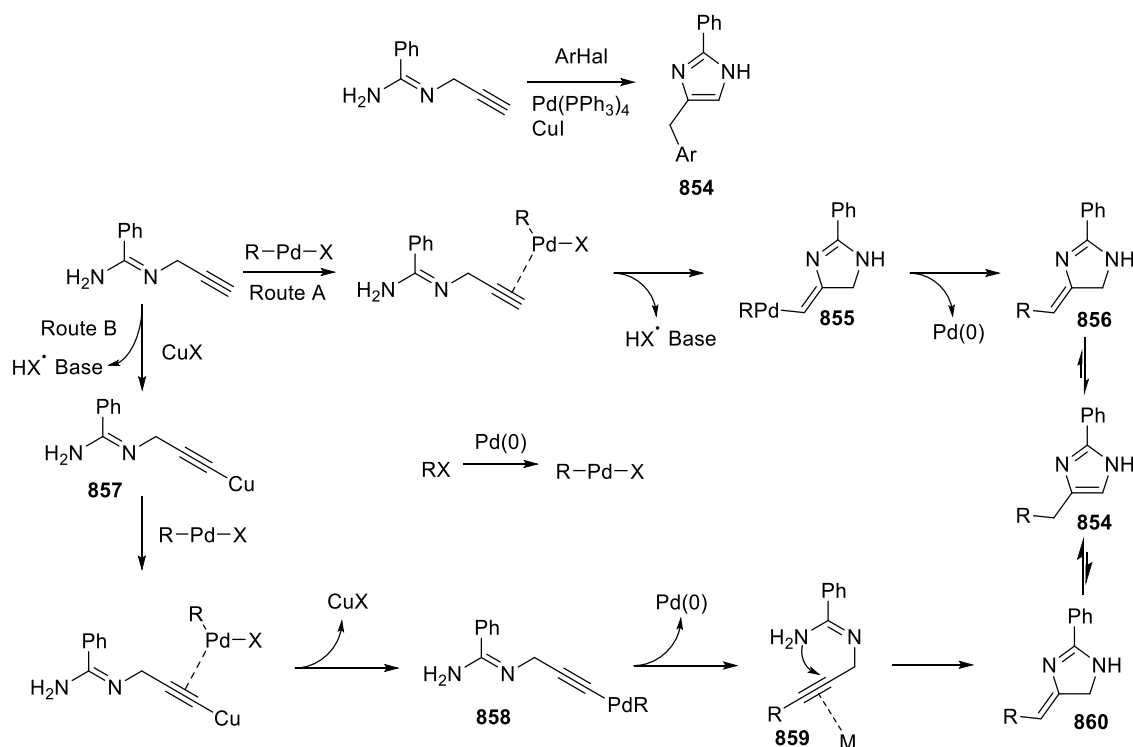

A similar process in which Sonogashira coupled products were cyclized using Pd(II) and converted into imidazoles by treatment with Et₃N was also reported by Bakerad *et al.*⁴⁵⁷

In 2012, Wu and co-workers described the conversion of propargylamidines **861** into imidazole **864** in the presence of PhP₃AuCl and AgSbF₆. The method was demonstrated to be highly compatible for a range of functional groups, with yields ranging from 60-87%. A plausible mechanism for the reaction is shown in Scheme 170.⁴⁵⁸

Scheme 170. Au-/Ag-catalyzed cyclization of propargylamidines.

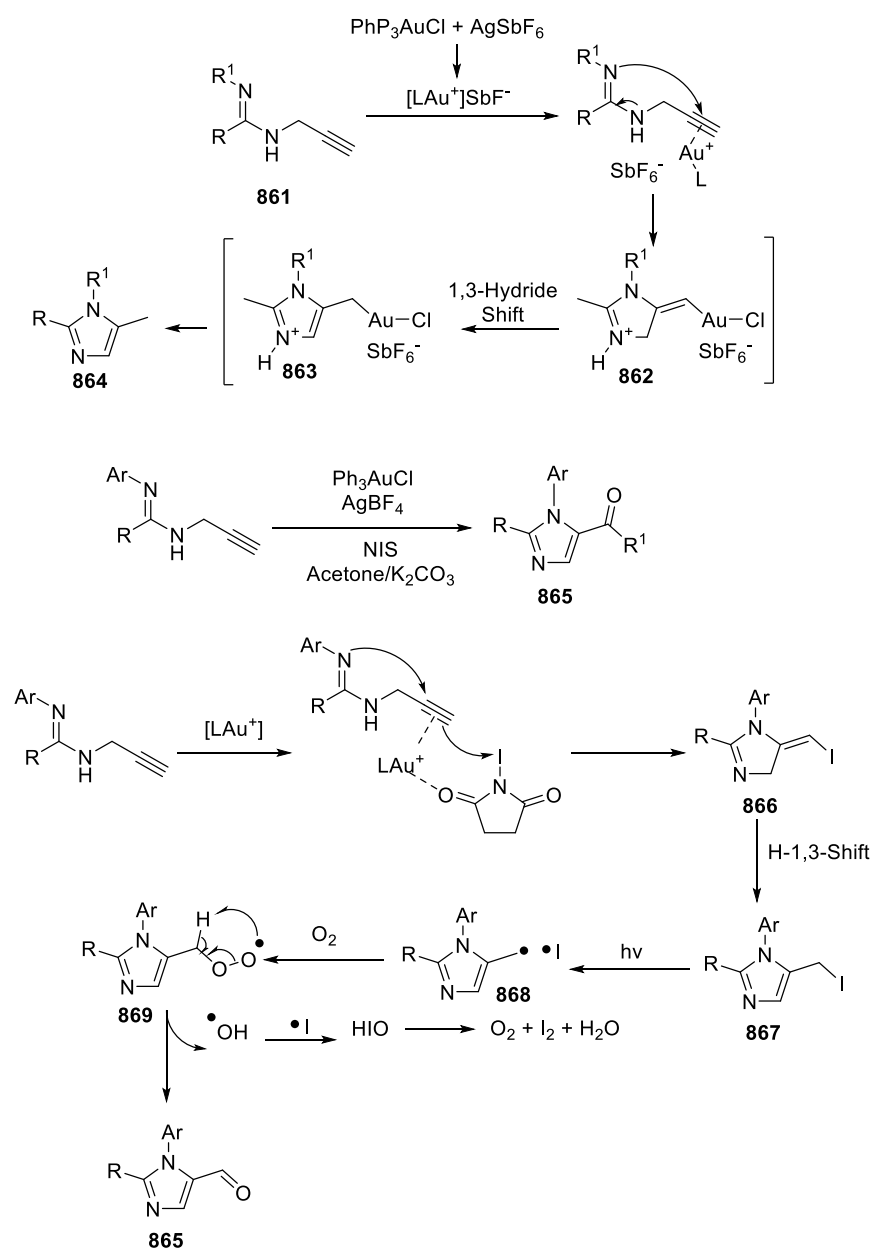

Interestingly, in order to functionalize the imidazole product, the authors demonstrated that it was also possible to obtain the carbonyl derivatives **865** (57-98% yields) simply by adding NIS to the reaction mixture. A possible mechanism for this transformation is reported in Scheme 170. Propargylamidine is first activated by $[\text{Ph}_3\text{PAu}^+]$ and reacts with NIS to afford 5-iodomethyl imidazole **867**. Then a radical process may occur, in which the C–I bond in **867** possibly dissociates into the radical intermediate **868** and an iodine radical. In the presence of O_2 , the peroxy-intermediate **869** is formed, leading in turn to aldehyde **865** by means of removing a hydroxyl radical.

This reaction was also extended to NCS and NBS. Unfortunately, when NCS was used, the reaction was unsuccessful, while the use of NBS led to a mixture of products, namely a major dibrominated product and a minor desired imidazole-carbaldehyde.⁴⁵⁹ Imidazoles have also been obtained through the reaction of propargylamines with nitrile derivatives as shown by Shen and Xie in 2010. The reaction between propargylamine **870** and nitriles was carried out using various metal monoamide catalysts. A titanium monoamide complex **871** was found to promote the reaction with the highest yields of up to 92% of the desired imidazoles.⁴⁶⁰ The mechanism of the cyclization is reported in Scheme 171.

Scheme 171. Reaction of propargylamines with nitriles catalyzed by titanium complex

871.

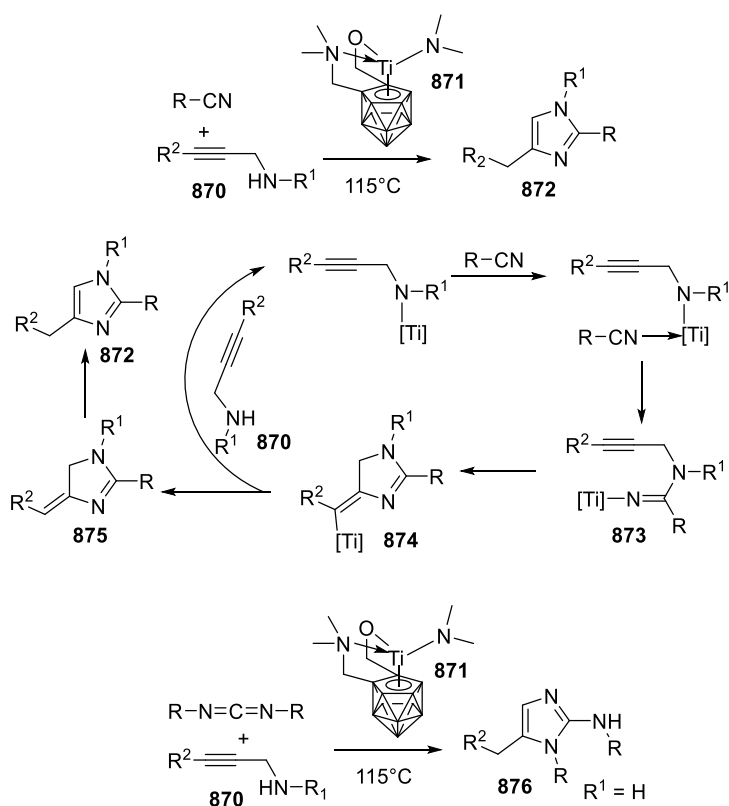

Furthermore, the catalyst was also reported to successfully yield 2-aminoimidazoles from the reaction of carbodiimides with propargylamines in 69-88% yield.⁴⁶¹ The addition of propargylamines to carbodiimides as a method for the synthesis of 2-aminoimidazoles has been also described later by Jin and co-workers. The reaction occurs in DMSO at 80 °C in the presence of NaOH and led to imidazole derivatives in 60-83% yields.⁴⁶²

Another interesting and efficient approach to imidazoles from propargylamides has been described by Beller. Propargylamides **877** react with various amines to yield imidazoles **878** in the presence of Zn(OTf)₂ resulting in 38-96% yields. The zinc catalyst promotes the hydroamination of the alkyne, leading to intermediate **879** which spontaneously cyclizes into imidazole **878**. (Scheme 172).⁴⁶³

Scheme 172. Zn-, Sm-, Yb-catalyzed synthesis of imidazoles.

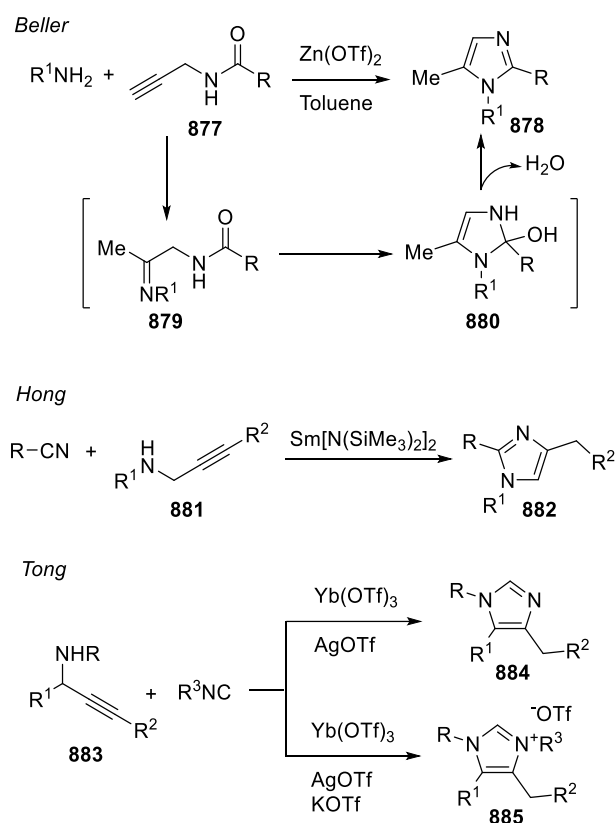

Recently, lanthanides, and in particular samarium reagents, were found to successfully catalyze the addition of nitriles to propargylamines. Treatment of the propargylamines **881** with nitriles in the presence of $Sm[N(SiMe_3)_2]_2$ led to imidazoles **882** in reasonable yields (21-93%).⁴⁶⁴ Scheme 172.

Ytterbium was also used to catalyze the reaction of propargylamines **883** with isocyanides which led to imidazoles **884** or imidazolium ions **885** in 51-99% and 65-95% yield respectively. The key distinction in the selectivity of this reaction is that the reaction with primary and secondary alkyl-isocyanides in the presence of $Yb(OTf)_3$, $AgOTf$ and $KOTf$ resulted in an imidazolium species **885**. In contrast, the reaction between **883** and *tert*-butylisocyanide with $Yb(OTf)_3$ and $AgOTf$ afforded imidazoles **884**.⁴⁶⁵ A reaction mechanism was proposed to explain this distinction.⁴⁶⁶

Finally, AgOTf has been also employed by two research groups for the synthesis of imidazoles from propargylamines. Wang and co-workers described the synthesis of 1,2,5-trisubstituted imidazoles **887** through the reaction of propargylamines with ketenimines,⁴⁶⁷ whilst Lavilla reacted propargylamines **888** with isocyanides in the presence of AgOTf to synthesize tetrasubstituted imidazolium salts **889**.⁴⁶⁸ Scheme 173.

Scheme 173. Ag-catalyzed synthesis of imidazoles.

Wang and co-workers

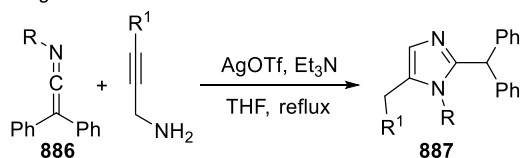

Lavilla and coworkers

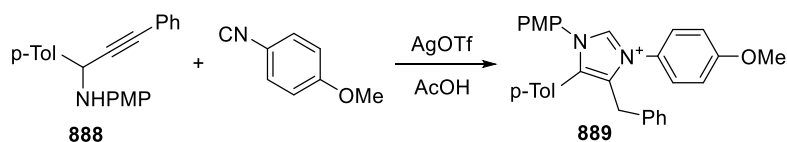

3.11 Synthesis of imidazolidin-2-ones, imidazol-2-ones and imidazolidine-2-thiones from propargylamines

Imidazolidin-2-ones **891** were first prepared in 50-78% yields in 1978 by Timberlake and co-workers by treatment of propargylureas with NaH.⁴⁶⁹ A more recent method of this transformation has been developed by Padwa who instead treated propargylurea **892** with AuCl₃ leading to imidazolidin-2-one **893** in a 68% yield. This latter isomerized to yield dihydroimidazol-2-one **894** following heating in toluene and in the presence of PTSA.³⁸³ Scheme 174.

Scheme 174. Cyclization of propargylureas into imidazolidin-2-ones.

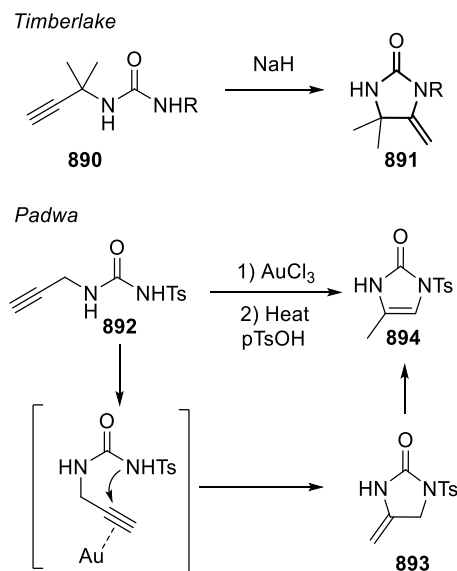

A gold catalyzed approach to imidazolidin-2-ones has been reported recently by Testero and co-workers. The authors reacted supported propargylureas **895** with AuCl to form imidazolidin-2-ones **896**. They remarked that propargylureas are ambident nucleophiles, and therefore the gold cyclization can either proceed using either the N or O of the urea. As a result, both *5-exo-dig* and *6-exo-dig* are possible cyclization pathways. In certain cases, imidazole-2-ones **897** were obtained through double bond migration (*entries 4-5*). Zwitterions **898** were also formed in some cases as cyclization products (*entries 8-9*). Table 37).⁴⁷⁰

Table 37. Gold-catalyzed cyclization of propargylureas

Entry	R	R ¹	R ²	R ³	n	Yield (%) (896/897/898)

1	Ts	NH ₂	H	H	1	87 (49:38:0)
2	Ts	OH	H	H	1	97 (25:72:0)
3	Ts	OH	H	H	2	75 (65:10:0)
4	Ts	OH	Me	Me	1	53 (0:53:0)
5	Ts	OH	Me	Ph	1	34 (1:34:0)
6	Ph	NH ₂	H	H	1	66 (63:3:0)
7	Ph	OH	H	H	2	96 (96:0:0)
8	Ph	OH	Me	Me	1	30 (0:0:30)
9	Ph	OH	Me	Ph	1	68 (0:0:68)

Imidazol-2-ones **901** were synthesized from propargylamines **899** through reaction with isocyanates, followed by cyclization with AgOTf by the group of Van der Eycken. The degree of variability attainable from this method makes it an extremely desirable and robust means of synthesizing imidazol-2-ones from propargylamines with both internal and terminal alkynes.⁴⁷¹⁻⁴⁷² A mechanism for the reaction is proposed in Scheme 175. The silver catalyst forms a complex with the triple bond of **900** favoring the cyclization into the intermediate **902** which is in turn converted into **903**. Silver mediated isomerization led finally to imidazol-2-one **901**.

Scheme 175. Ag-catalyzed synthesis of imidazol-2-ones.

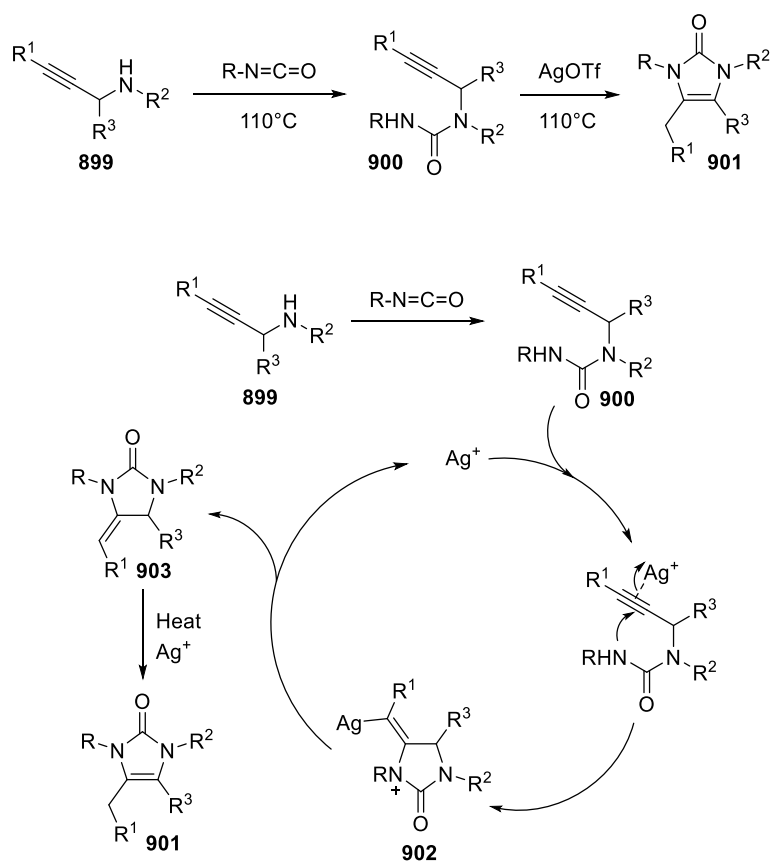

Proulx and Lubell recently described the synthesis of *N*-amino-imidazolin-2-one derivatives from propargyl-hydrazones.⁴⁷³⁻⁴⁷⁴ Finally, tetrasubstituted imidazole-2-thiones **906** and imidazol-2-ones **907** can be also synthesized from propargylamines **904** through reaction with iso(thio)cyanates under basic conditions. The reaction leads to the formation of (thio)urea intermediates **905** which are susceptible to cyclization *via* an intramolecular hydroamination-isomerization reaction to afford compounds **906-907** in good yields (Scheme 176).⁴⁷⁵

Scheme 176. Synthesis of imidazole-2-thiones and imidazol-2-ones from propargylamines.

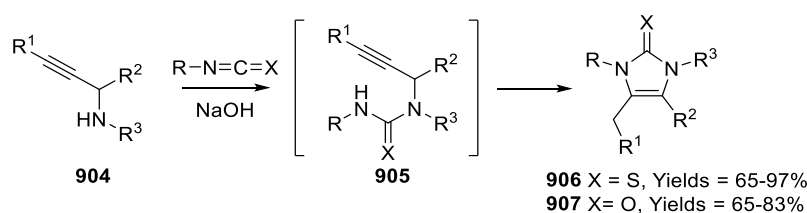

3.12 Synthesis of triazoles from propargylamines

Triazoles find application in both pharmaceutical and agricultural industry. For example, they can be employed not only as potent antifungals as well as fungicides, but also as dyes, optical brighteners, corrosion inhibitors and biologically-active agents. The core scaffold of these compounds consists of a 5-membered aromatic ring bearing three nitrogen atoms. According to the position of the nitrogen atoms, triazoles are identified as 1,2,3- or 1,2,4-triazoles. A number of methods to synthesize 1,2,3-triazoles from propargylamine cyclization of propargylamines have been developed.

3.12.1 Copper-catalyzed synthesis of triazoles from propargylamines. Since the introduction of Cu(I) salt catalysts for the thermal Huisgen 1,3-dipolar cycloaddition between alkynes and azides, the Cu(I)-catalyzed azide-alkyne 1,3-cycloadditions (CuAACs) have become a popular approach to synthesize 1,2,3-triazoles in a regioselective 'click-chemistry' fashion. Propargylamines can obviously be used as alkyne substrates, together with copper iodide as the catalyst of choice. Remarkably, the efficiency of this catalyst in the synthesis of 1,2,3-triazoles from propargylamines has enabled researchers to achieve very complex molecules even under very mild conditions. These exceptionally diverse systems found application in various branches of chemistry such as coordination chemistry,⁴⁷⁶⁻⁴⁷⁸ medicinal chemistry⁴⁷⁹ and nanomaterials.⁴⁸⁰ Among the most important applications, propargylamines have been successfully employed as substrates for the design of potential triazole imaging

agents,⁴⁸¹⁻⁴⁸² anticancer compounds,⁴⁸³ peptidic dendrimers⁴⁸⁴⁻⁴⁸⁶ and triazolopeptoids,⁴⁸⁷ polymers,⁴⁸⁸ as well as metallocene-based anhydase inhibitors.⁴⁸⁹ Furthermore, the development of solid-phase supported copper catalysts has enabled the creation of wide libraries of triazolic compounds.⁴⁹⁰ These applications are precised in Scheme 177.

Scheme 177. Triazole derivatives synthesized from propargylamine precursors.

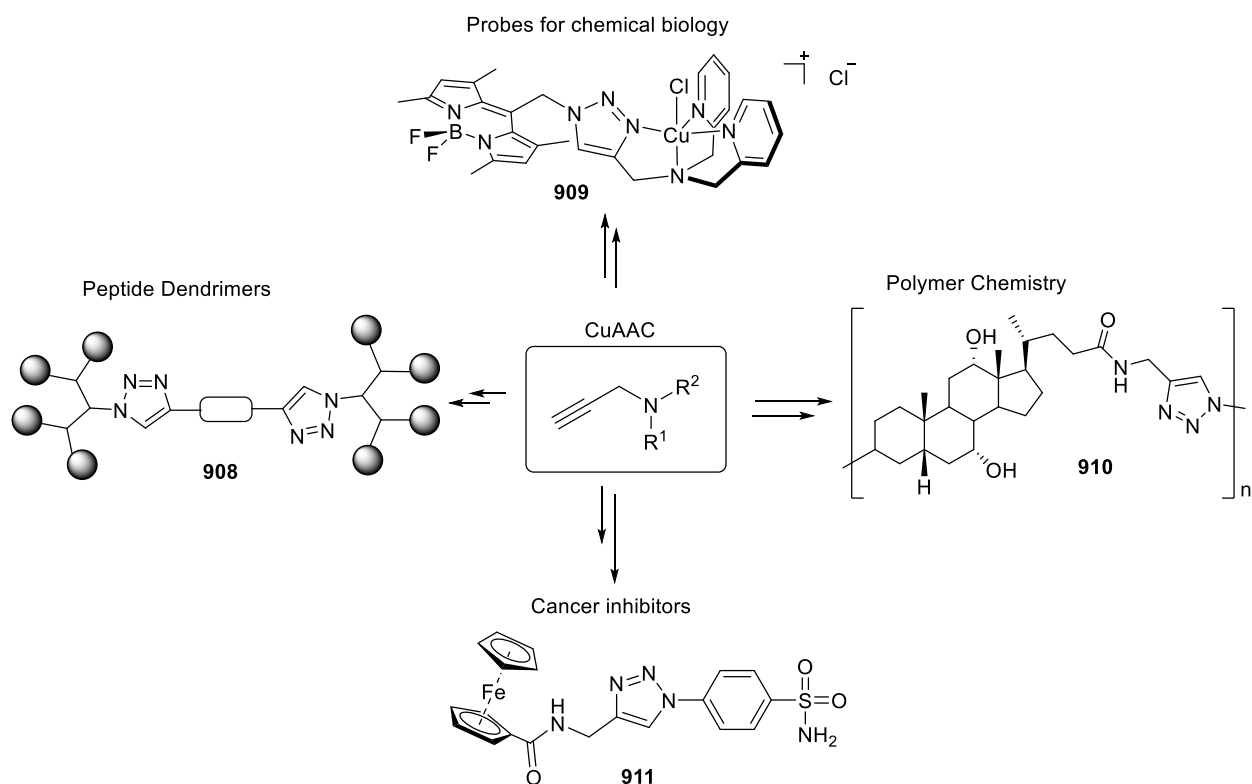

Among their many uses, propargylamines have been incorporated in peptidic scaffolds for macrocycloaddition reactions. In this regard, Angell and Burgess exploited the CuAAC to synthesize the peptidic β -turn mimics **913**.⁴⁹¹ In a similar manner, the creation of a propargylamino- and N_3 -capped termini led Schreiber and co-workers to obtain the conformationally-restricted small molecule **915** through a head-to-tail cycloaddition.⁴⁹² It is worth noting that the authors developed a macrocycloaddition strategy based on modular systems which enables the facile variation of stereochemistries and substituents in 17- and 21-membered macrocycles in the presence of Cu(I). Other symmetric heterocyclic pseudo-

hexapeptides **917** could be achieved through a tandem dimerization-macrocyclization approach described by Ghadiri.⁴⁹³ Scheme 178.

Scheme 178. Synthesis of macrocycles via CuAAC.

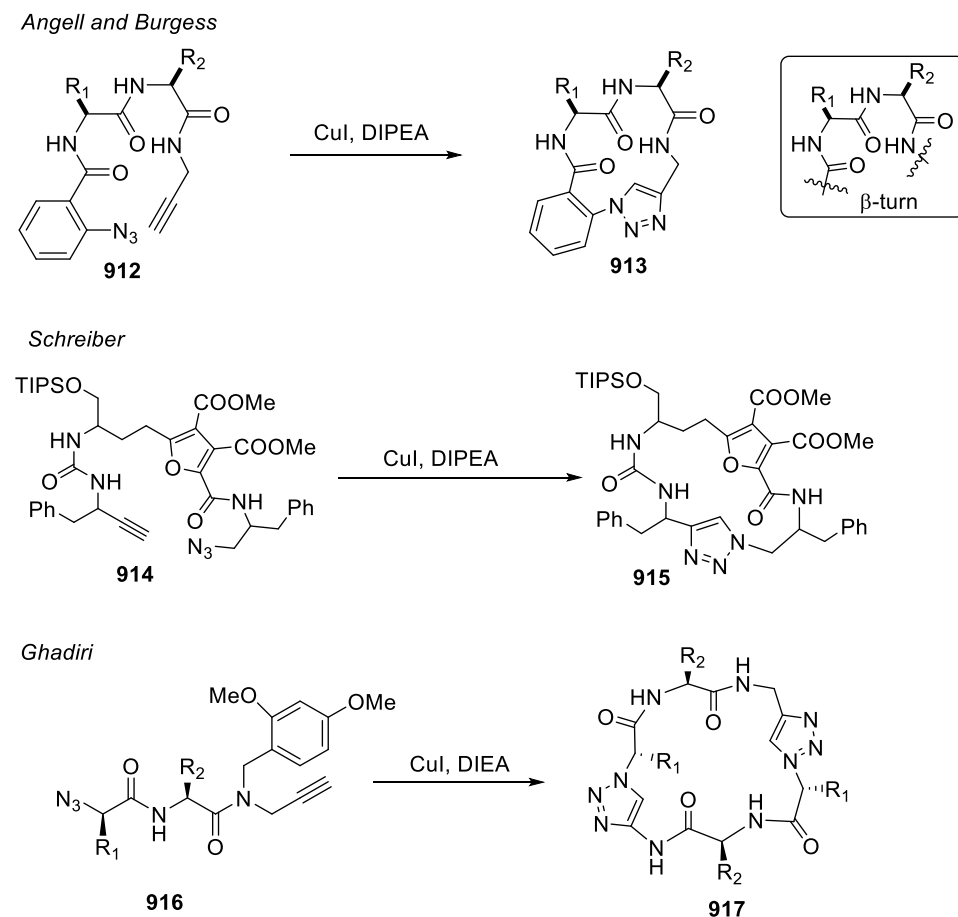

Catalytically-active Cu(I) species can be generated *in situ* from Cu(II) (e.g. CuSO₄, Cu(OAc)₂, Cu(OTf)₂) with the use of a reducing agent; this popular methodology enables the preparation of 1,2,3-triazoles from propargylamines in good to excellent yields and allows these valuable compounds to be used in a wide range of applications. Mono- and di-functionalized 1,2,3-triazoles **919** can be obtained from mono- and dipropargylated anilines **918** respectively in the presence of Cu(OAc)₂·H₂O as catalyst, sodium ascorbate as the reducing agent and 1,10-phenanthroline as Cu(I)-stabilizing agent, as reported in Scheme 179.⁴⁹⁴

Scheme 179. Synthesis of triazole 919 from dipropargylamine 918.

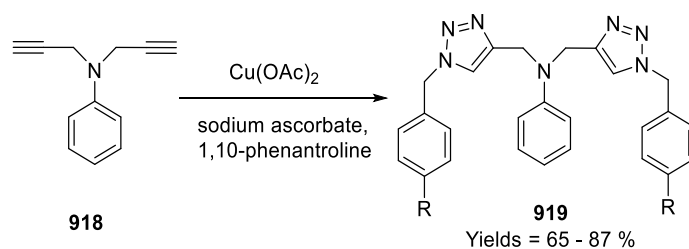

An interesting use of this methodology was applied by Loison *et al.* in the design of a series of fluorescent benzazepine ligands for the arginine-vasopressin V2 receptor.⁴⁹⁵ Different nonpeptidic ligands were combined with various fluorescent dyes *via* the reaction of propargylamine **920** with an azide-capped PEGylated dye in the presence of CuSO_4 and sodium ascorbate, affording ligands **921** (Scheme 180).

Scheme 180. Synthesis of fluorescent benzazepine ligands *via* CuAAC.

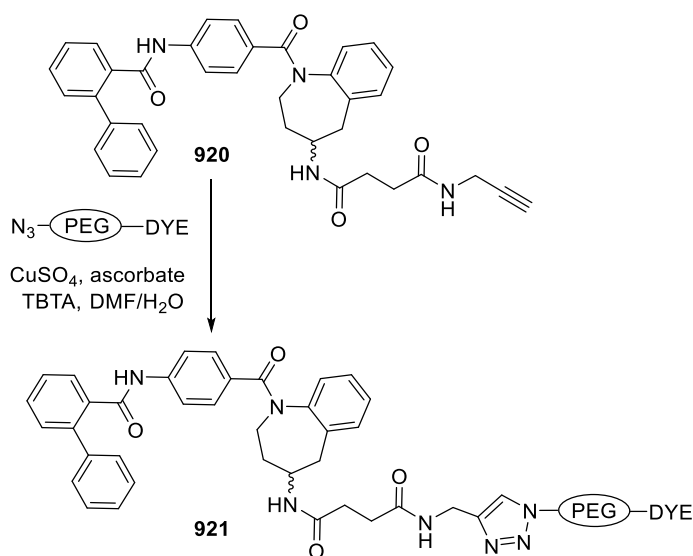

Similar approaches have been used for the synthesis of antifungal compounds,⁴⁹⁶⁻⁴⁹⁸ antimicrobials,⁴⁹⁹⁻⁵⁰⁴ enzyme, fluorescent⁵⁰⁵ and fluorogenic⁵⁰⁶⁻⁵⁰⁷ probes for chemical biology, G-Quadruplex inhibitors,⁵⁰⁸ and fluorescent sensors for the detection of ionic gold was also reported.⁵⁰⁹ 'Click-chemistry' using propargylamines was likewise extended to the development of glycomers and glyco-nucleosides⁵¹⁰⁻⁵¹¹ and to the preparation of cavitands for the extraction of metals,⁵¹² as well as for the synthesis of novel biphosphonate-containing

compounds for the diagnosis and treatment of bone diseases.⁵¹³ Novel triazole-containing antitubercular compounds **924** were also obtained from differently-substituted propargylamines **922** through a domino 1,3-dipolar cycloaddition-alkylation reaction with NaN_3 and BnCl (Scheme 181).⁵¹⁴⁻⁵¹⁵ Interestingly, the 1,3-cycloaddition reaction can also be performed *via* a tandem silyl deprotection and triazole formation such in the synthesis of triazole **926** from silyl-protected propargylamines **925** and benzoylazide in the presence of a source of fluorides (*e.g.* TBAF).⁵¹⁶ Various catalysts, such as CuCl , Cu powder and Cu(II) salts were tested in this work, with Cu(OTf)_2 and $\text{CuF}_2 \cdot \text{H}_2\text{O}$ giving the best conversions (Scheme 181).

Scheme 181. Tandem and domino syntheses of triazoles.

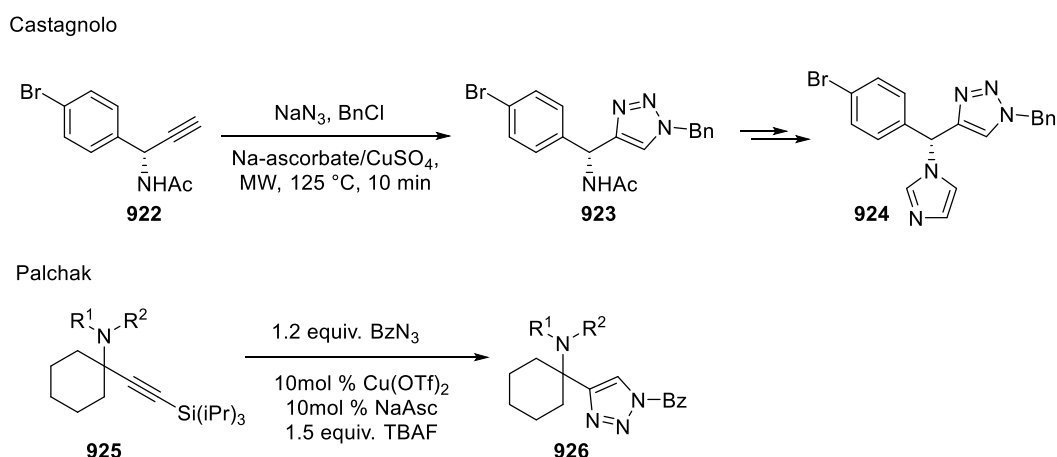

The use of propargylamines proved to be pivotal in the work by Roy *et al.* in which tetrahydro-[1,2,3]triazolopyrazine heterocyclic moieties **929** have been synthesized from **927** *via* a tandem “click” cycloaddition/*6-exo-dig* cyclization in mixed aqueous–organic media. The simple synthetic route developed by the authors allowed for a series of 1,2,3-triazole-fused pyrazines to be afforded in good yields. The dipropargylamine starting material **927** was used as model compound for the tandem ‘click-cyclization’ reaction, which was performed at 80 °C in a 1:1 mixture of water and *tert*-butanol in the presence of sodium azide and $\text{CuSO}_4 \cdot \text{H}_2\text{O}$ and sodium ascorbate as catalyst. The tandem reaction is initiated by the

formation of the 1,2,3-triazole ring **928** via ‘click’ 1,3-dipolar cycloaddition between the azide and one of the alkyne groups of the propargylamine **927**. Subsequently, a constrained intramolecular *6-exo-dig* cycloaddition between the triazole and the terminal alkyne of the dipropargylamine affords the desired 1,2,3-triazole-fused 4,5,6,7-tetrahydropyrazine **929**. The mechanism of the reaction, including the orbitals involved in the *6-exo-dig* cyclization, is depicted in Scheme 182. The scope of this reaction was investigated by employing different *N,N*-dipropargylamine precursors. From the results, it appears that all of the dipropargylamines **927** used in this study (bearing either electron-withdrawing or electron-donating substituents) lead to the formation of the desired products **929a-f** in good to excellent yields (66-93%). Notably, when unsymmetrical dipropargylamines bearing a terminal and an internal alkyne were used, no product resulting from the *6-exo-dig* cyclization was formed. Only the acyclic product derived from the intermolecular ‘click’ 1,3-dipolar cycloaddition appeared to be exclusively formed. This result clearly indicates that the tandem click cycloaddition/cyclization reaction mechanism suggested by the authors can only occur when terminal di-propargylamines are employed whilst it is disfavored with internal dipropargylamines.⁵¹⁷

Scheme 182. Tandem click cycloaddition/cyclization reaction of dipropargylamines.

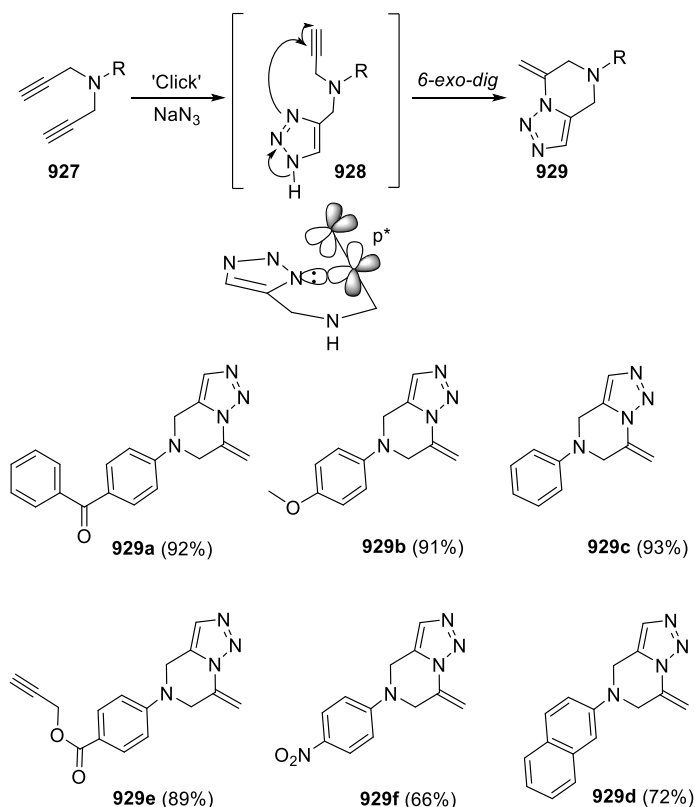

Although Cu(I) salts are the most convenient catalysts for CuAACs, the generation of Cu(I) species from CuSO₄/ascorbate and metallic copper have also been reported. However, following the findings by Sharpless and Fokin on the successful use of metallic copper turnings, examples where Cu(0) and CuNPs have been used as catalysts can be found in the literature. For example, Orgueira and co-workers reported the efficient cyclization of propargylamine hydrochloride and benzyl azides catalyzed using a Cu(I)-generated catalyst derived from the activation of Cu(0) nanosized powder.⁵¹⁸ The reaction, performed in a water/*tert*-butanol mixture with a 10 mol% loading of the copper powder, required the use of propargylamine hydrochlorides instead of propargylamines only as reaction substrates; the reason for this was that the catalyst exhibited increased solubility in a slightly acidic environment, which therefore allowed the generation of the Cu(I) species and triggered the conversion of the substrates into the desired 1,4-disubstituted [1,2,3]-triazoles. The chemistry proved to be successful with aliphatic, benzylic and aryl azides, and showed good tolerance

towards electron-donating and electron-withdrawing functional groups on both the alkyne and azide starting materials, indicated in Table 38.

Table 38. Synthesis of triazoles from propargylamine hydrochloride using Cu(0) nanosized powder.

930

Entry	Triazole	Yield (%)
1		94
2		93
3		95

Propargylamines were also employed for the development of new bioconjugation strategies in the presence of nanoparticles. An important advancement in bioconjugation is represented by the recent work of Bradley and co-workers, in which a triphenylphosphonium-conjugated propargylamine **932** and 3-azido-7-hydroxycoumarin **931** were 'clicked' together with the use of a heterogeneous and biocompatible copper catalyst. In this work, these polymer-embedded copper nanoparticles (CuNPs) were successfully employed to enable the *in situ* synthesis of cytotoxic anticancer agents through a 1,3-cycloaddition reaction.⁵¹⁹ Scheme 183. This contribution has emerged due to the demand of new *in vivo* ligation tools that would circumvent the use of toxic Cu(I) species in living systems.

Scheme 183. 1,3-Cycloaddition using polymer-embedded copper nanoparticles.

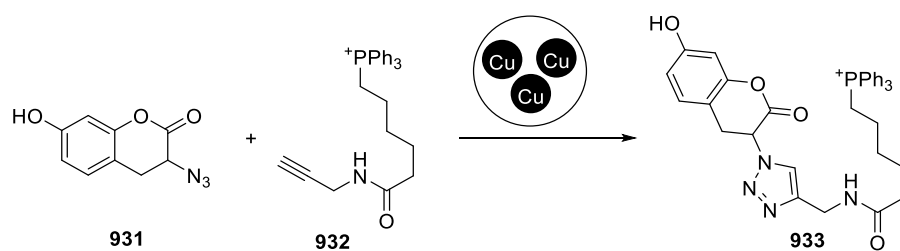

3.12.2 Other metal-catalyzed synthesis of triazoles from propargylamines. Although the Cu(I)-catalyzed cycloaddition reaction has proved to be an extremely efficient and thus extensively exploited resource for synthetic chemists, the synthesis of 1,2,3-triazoles from propargylamines has also been investigated by the means of other metals, such as ruthenium, indium and silver. The use of these metals becomes critically important from the point of view of regioselectivity, as CuAACs provide access to 1,4-substituted isomers only. Thus, the need for selective access to the complementary regioisomers, like for example, the 1,5-disubstituted triazoles, has become essential. Examples of metal-catalyzed 1,3-dipolar cycloadditions using propargylamines that lead to 1,4- and 1,5-disubstituted triazoles are reported below. An ingenious and green method to perform A^3 coupling reactions in combination with 1,3-cycloaddition reactions using a single catalyst was designed by Cao *et al.*. This novel methodology is based on the creation of a polyacrylonitrile fiber-supported *N*-heterocyclic carbene silver complexes (PANF-NHC-Ag), which facilitates the generation of the propargylamine starting materials **934** and then catalyzes the subsequent intramolecular 1,3-dipolar cycloaddition to yield the corresponding triazoles **936**. Notably, as this sustainable continuous-flow process can be adapted to a microreactor set-up, the diastereoselective synthesis of several fused triazoles **936** can also be achieved under high temperatures and pressures. The tandem reactions proceed according to the mechanism reported in Scheme 184.⁵²⁰

Scheme 184. Ag-catalyzed domino A³ coupling/1,3-cycloaddition reactions.

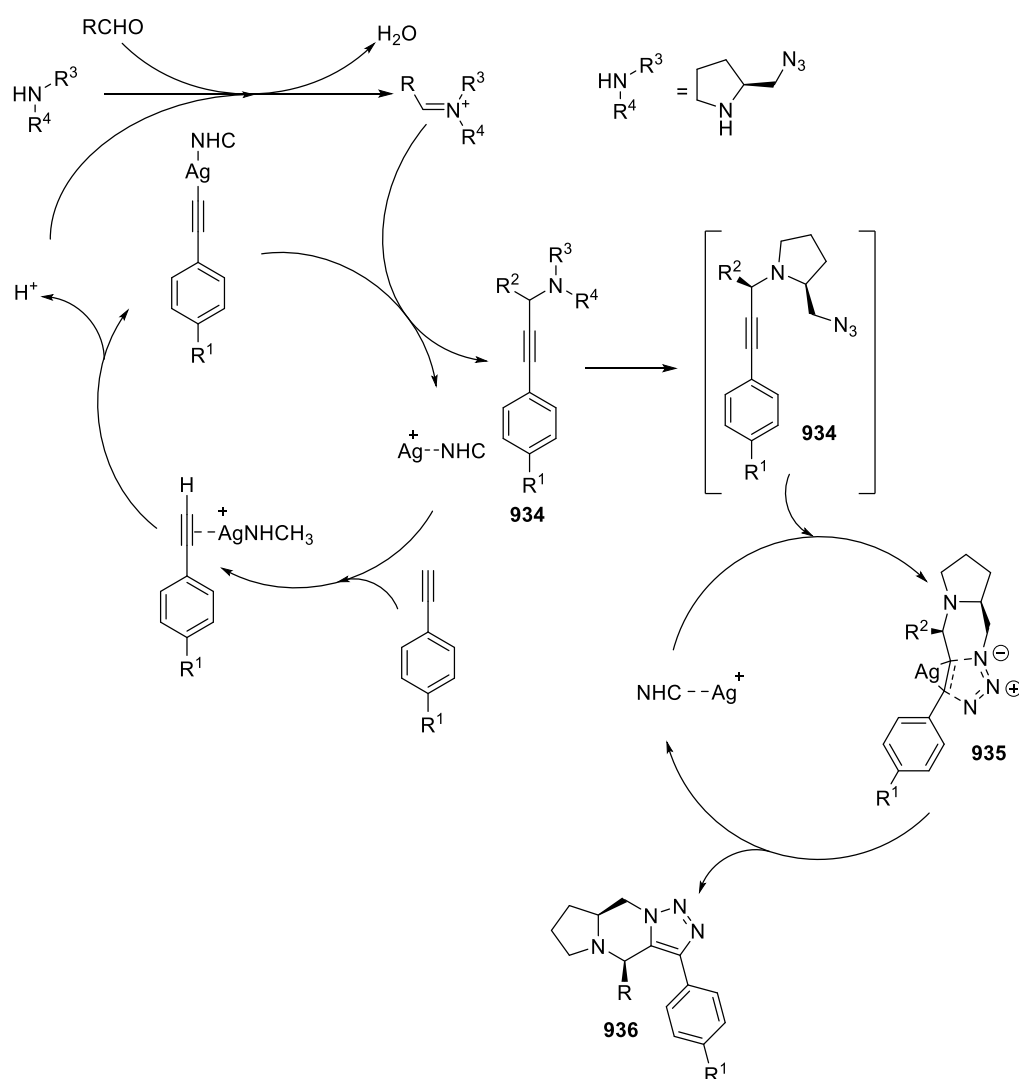

Among various metals, indium(III) has been demonstrated to be active in tandem cyclocondensation and intramolecular Huisgen 1,3-dipolar cycloaddition reactions using a wide scope of differently-substituted propargylamines, α -diketones and 2-azidobenzaldehyde as substrates. The multicomponent two-step cascade methodology described by Nguyen *et al.* consists of a one-pot procedure that affords imidazo-triazolobenzodiazepines in reasonable yields.⁴⁵³ Notably, this methodology allows access to 1,5-disubstituted triazoles instead of the 1,4-isomer, which is regioselectively favored *via* classical CuAAC.

The well-known catalytic properties of ruthenium have been extensively exploited in numerous transformations of alkynes. With regards to ruthenium-catalyzed 1,3-

cycloadditions, the ground-breaking work of Fokin, Jia and co-workers has paved the way for the use of ruthenium complexes as efficient catalysts for the synthesis of both 1,4- and 1,5-disubstituted triazoles, with the discovery of $\text{Cp}^*\text{RuCl}(\text{COD})$ being able to catalyze the regioselective formation of the 1,5-substituted isomer.⁵²¹ Inspired by this work, Ballet and co-workers have broadened the scope of the reaction by employing propargylamines as acetylene source, thus developing two efficient synthetic routes for the preparation of amino-triazolodiazepines **939** as conformationally constrained amino acid mimics (Scheme 185).⁵²² Two synthetic routes were proposed and the key reaction in both routes is the regioselective cycloaddition that leads to the formation of 1,5-substituted triazoles. The first route envisages the creation of a ruthenium-catalyzed 1,5-substituted triazole **938** followed by lactamization, whilst the second route proceeds through a Huisgen cycloaddition reaction, in which the lactam and the triazole rings are formed simultaneously. The latter strategy, which does not require the use of a metal catalyst, was also successfully applied by Pokorski *et al.* to access the 1,5-substitution pattern.⁵²³

Scheme 185. Ru-catalyzed synthesis of 1,5-substituted triazoles.

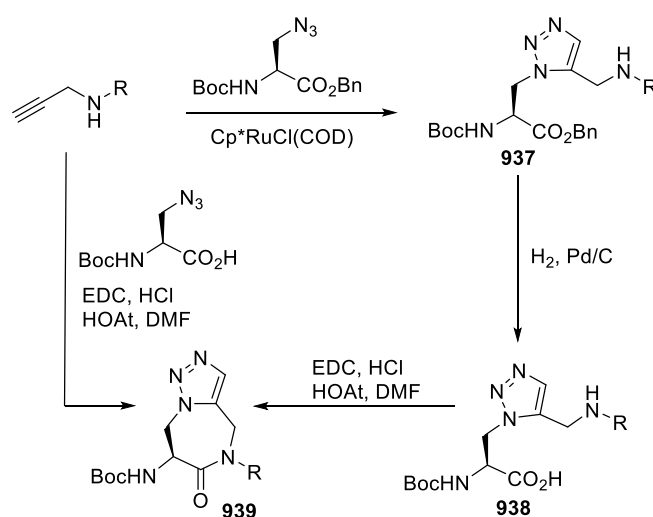

3.12.3 Metal-free synthesis of triazoles from propargylamines. Despite their successful employment as catalysts in 1,3-dipolar cycloaddition reactions, the use of transition metals

still hampers the potential adaptability of this class of reactions to biological systems. In addition, the metal-catalyzed synthesis of fused 1,2,3-triazole scaffolds remains quite problematic due to the steric hindrance and often low reactivity of the starting materials. For these reasons, alternative metal-free methodologies for the synthesis of triazoles have become highly desirable. In this regard, Niu *et al.* have recently reported an efficient chemoselective protocol for the syntheses of unsymmetrical bis(1,2,3-triazole) derivatives, which utilizes propargylamines as bifunctional linkers to perform a copper-free three-component cycloaddition followed by a classical CuAAC.⁵²⁴ The optimized methodology involves a three-component reaction between propargylamine, an azide and diketene catalyzed by DBU in a methanolic solution. The resulting monotriazole compound **940**, bearing an additional alkyne functionality, is then reacted with another azide in the presence of CuI, according to a classical CuAAC, shown in Scheme 186. It is noteworthy that both the metal-free and the subsequent copper-catalyzed cycloaddition can be performed as a “one-pot” tandem reaction. Remarkably, this methodology enabled the chemoselective preparation of unsymmetrical bis(1,2,3-triazoles)-modified peptidomimetics as well as 1,4- and 1,5-membered triazole-containing macrocycle compounds.⁵²⁵

Scheme 186. Metal free syntheses of triazoles

Niu

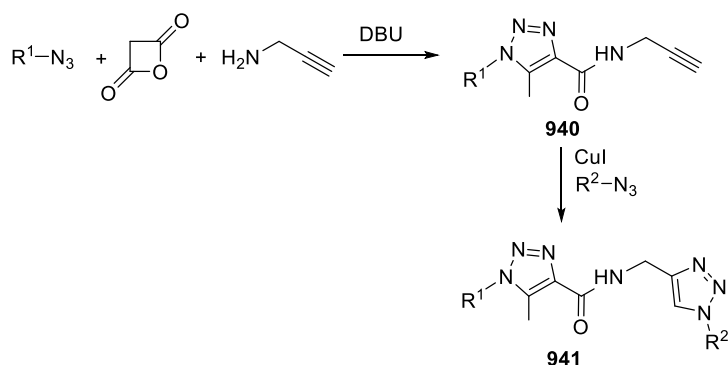

Guggenheim

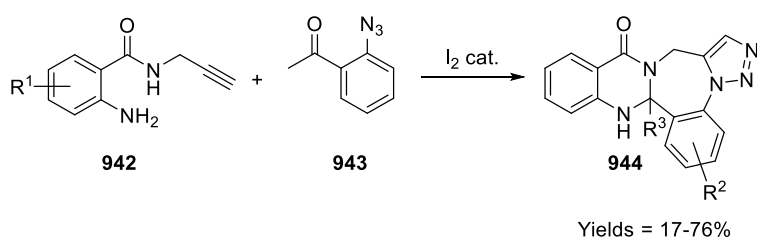

In addition to organobases, iodine has also been employed as a suitable catalyst for azide-alkyne cycloadditions. With regards to propargylamines, Guggenheim *et al.* developed a straightforward one-pot cascade for the synthesis of quinazolino[1,2,3]triazolo derivatives **944** using iodine as catalyst.⁵²⁶ This green methodology proceeds through an initial quinazoline formation/condensation reaction coupled with a sequential iodine-catalyzed intramolecular 1,3-dipolar cycloaddition. This atom-economical two-step synthesis allows the preparation of diversity-oriented quinazolino-triazoles **944** from propargylamines **942** in good yield and purity (Scheme 186). Most importantly, the use of this catalyst enables the access to 1,5-substituted triazoles and the formation of complex fused systems.

In a similar manner, Kundu and co-workers have recently indicated an efficient route for the preparation of triazole derivatives **947**, in which the formation of a benzimidazole, achieved through cyclocondensation/oxidation reactions, is followed by the formation of a fused diazepine-triazole system *via* an iodine-catalyzed 1,3-dipolar cycloaddition. As showed in Scheme 187, the treatment of *N*-alkyne-1,2-phenyl diamine **945** with 2-azidobenzaldehyde

946 in the presence of iodine (10 mol%) at moderate temperatures leads the formation of compounds **947** in good to excellent yields. This methodology has shown good tolerance in regards to the substituents on both the phenyl rings and the acetylenic group of the propargylamine, and provides a valid and efficient route to access biologically important scaffolds.⁵²⁷

Scheme 187. Iodine catalyzed synthesis of triazole derivative 947.

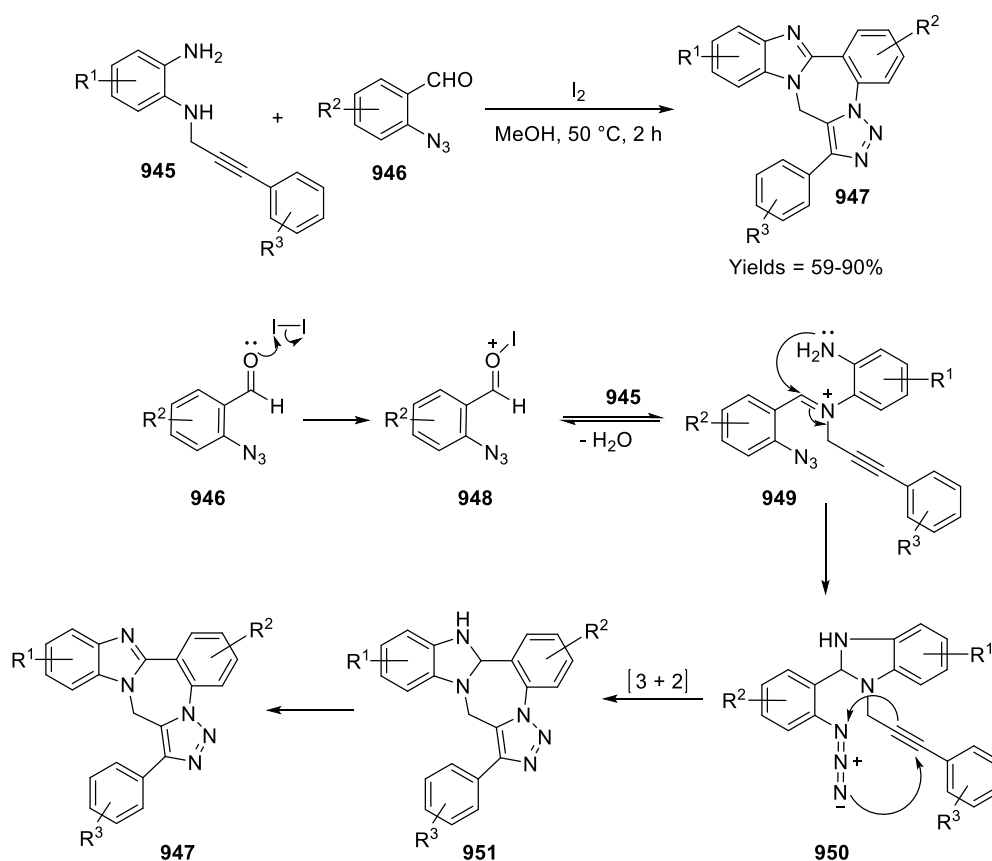

Another methodology for the synthesis of highly diversified [1,2,3]-triazolo[1,5-*a*][1,4]benzodiazepines based on the metal-free 1,3-dipolar cycloaddition of azide-propargylamines was recently published by Perumal and co-workers.⁵²⁸ Similarly to the above-mentioned work, the synthetic strategy adopted by the authors involves the use of a substituted *N*-alkyne-1,2-phenyl diamine **952** to perform an aqueous one-pot diazotization/azidation/cycloaddition reaction, in the presence of $NaNO_2/HCl$ and sodium azide. The *in situ* generation of the organoazide, followed by the 1,3-cycloaddition reaction

leads to the formation of the desired triazolo-1,4-benzodiazepines **953** in a single step and under mild conditions. Alternatively, triazole-fused 1,4-benzodiazepine scaffolds **954** can be obtained through the reaction of propargylamine with a substituted 2-azidobenzaldehyde as shown by Donald and Martin. The reaction consists of an acid-catalyzed reductive amination reaction followed by a Huisgen 1,3-cycloaddition.⁵²⁹ The amino group as well as the substituent (e.g. $R^1 = \text{Br}$) on the benzodiazepine ring offers the opportunity for further diversification of the resulting scaffold. Scheme 188.

Scheme 188. Synthesis of triazolo-1,4-benzodiazepines.

Perumal

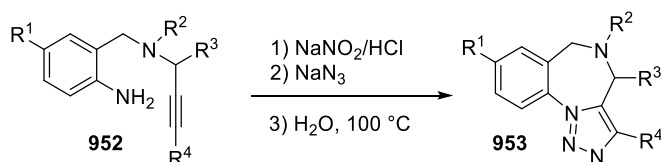

Donald and Martin

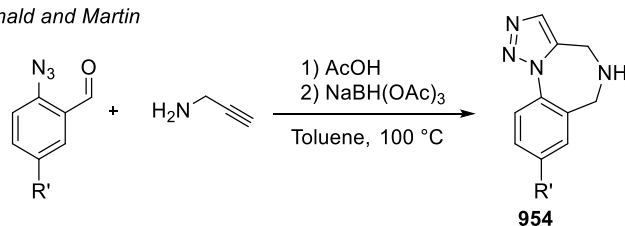

3.13 Synthesis of other heterocycles from propargylamines

The following section provides an overview of the different methods to synthesize various nitrogen-heterocyclic compounds, other than those previously reported, from propargylamines.

Madaan *et al.* described a one-pot three-step method for the synthesis of oxa(thia)zolidin-2-imine derivatives. Propargylamines were first synthesized by A^3 coupling with CuI , which were then converted to *N*-propargyl(thio)ureas by reaction with iso(thio)cyanates. Propargyl(thio)ureas are susceptible to cyclize following treatment with iodine and a base, leading to oxazolidin-2-imines with overall yields of 30-80%.⁴³³

Cyclic amine boranes **956** can be synthesized from propargylamines *via* a novel and highly effective method as described by Shi and co-workers. Propargylamine boranecarbonitriles **956** were first synthesized by treating propargylamines hydrochloride with NaBH₃CN. Compounds **955** were obtained in good-excellent yields. The structure of these intermediates was confirmed by X-ray crystallography. Then, treatment of **955** with the Au(I) catalyst [XPhosAu/TA]*OTf led to cyclic amine boranes with excellent yields. As before, the structure of **956** was confirmed by X-ray analysis.⁵³⁰ Scheme 189.

Scheme 189. Synthesis of cyclic amine boranes.

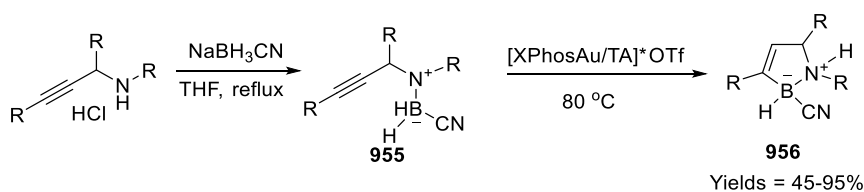

Imidazo-pyridines are an interesting class of organic compounds with application in medicinal chemistry. Boc-protected propargylamines **957** have been used as substrates for the synthesis of derivatives **958** through a water-mediated intramolecular hydroamination reaction by Adimurthy and co-workers. The reaction was carried out at 120 °C in water under argon atmosphere leading to **958** in 54-99% yields (Scheme 190).⁵³¹

A similar reaction has been also described by Kumar, who converted propargylamines into imidazo-pyridines using ^tBuOK at lower temperatures.⁵³² In parallel, Chioua described the synthesis of imidazo-pyridines from Boc-deprotected propargylamines using AgOTf as catalyst at 85 °C.⁵³³

A silver catalyzed aminoxygenation reaction of propargylamines **959** leading to imidazolo-pyridines **960** has been also described by Adimurthy. Carbonyls were inserted between the imidazole ring and R¹ group in 36-85% yields. The mechanism of reaction is reported in Scheme 190. Propargylamine **959** first reacts with a metal catalyst to generate a metal alkyne π -complex, which cyclizes to yield intermediate **961**. Successively, the addition of oxygen

generates organosilver peroxide intermediate **962**. Aromatization and subsequent isomerization to intermediate **964** occurs, followed by elimination of Ag(I) species with the formation of the desired product **960**. From the intermediate **961**, elimination of silver species and concomitant 1,3-prototropic shift can lead to the side product **966**.⁵³⁴

Scheme 190. Synthesis of imidazo-pyridines from propargylamines.

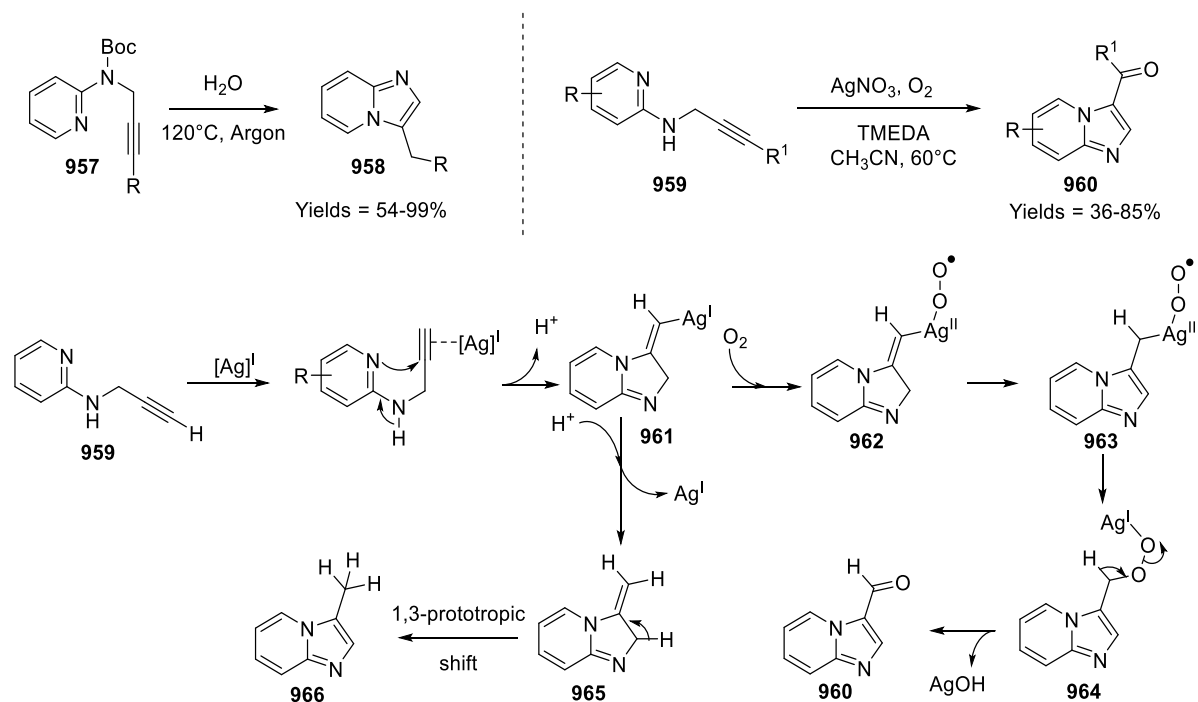

Propargylpyridinium derivatives can also be used as substrates for the synthesis of imidazolo-pyridines. The cyclization step can be catalyzed by Pd(PPh₃)₄⁵³⁵ or carried out under metal-free conditions in water.⁵³⁶

Two works are noteworthy for the synthesis of other nitrogen heterocycles from propargylamine derivatives. Michihiko described the synthesis of **968** and **969** from propargylamino derivatives **967**⁵³⁷ whilst Fokin reported the synthesis of 7-aza-5-deazapurine analogues *via* Cu(I)-catalyzed hydroamination of **970**.⁵³⁸ Scheme 191.

Scheme 191. Synthesis of guanidine and purine heterocyclic compounds.

Michihiko

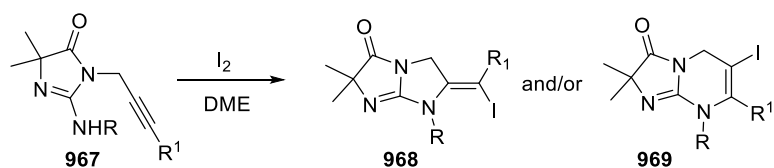

Fokin

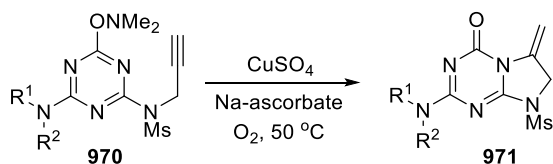

Broggini and co-workers reported the conversion of propargylamines **972** into imidazoindoles **974** or dihydropyrazines **975** via a two-step sequence. Propargylamines **972** were converted into allenes **973** by treatment with ^tBuOK and these were in turn cyclized to imidazoindoles **974** when heated in toluene under microwaves in absence of Pd(0) catalyst, or to dihydropyrazines **975**, when treated with Pd(PPh₃)₄ under microwave irradiation (Scheme 192).⁵³⁹

Van der Eycken and co-workers recently developed an elegant approach to furnish diversely substituted spiroindolines **978** in 40-89% yields through a gold catalyzed Ugi four-component domino reaction of propargylamine with 3-formylindole and various acids and isonitriles. The reaction proceeds via an *5-exo-dig* attack in the hydroarylation step followed by an intramolecular diastereoselective trapping of the iminium ion intermediate **977** (Scheme 192).⁵⁴⁰

Scheme 192. Pd- and Au-catalyzed approaches to polycyclic heterocycles.

Broggini

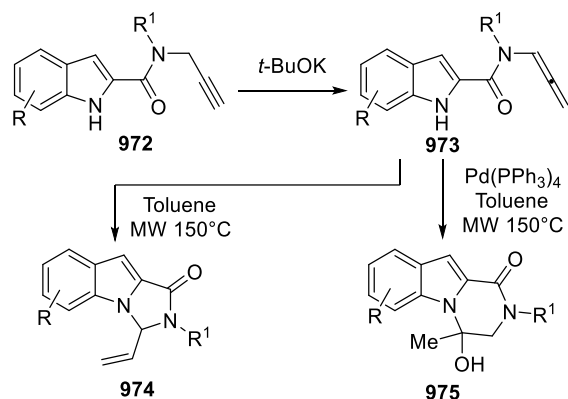

Van der Eycken

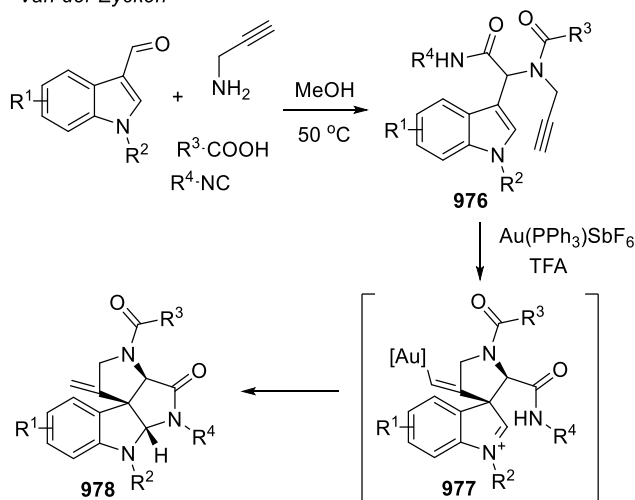

Recently, Wan and co-workers explored the reaction of propargylamides with TMSN_3 and NIS that led to the formation of interesting heterocyclic derivatives. When terminal propargylamines **979** ($\text{R}^2 = \text{H}$) were treated with NIS and TMSN_3 at 60°C the dihydroimidazoles **980** were obtained as the major products. On the other hand, when the same reaction was carried out on internal alkynes ($\text{R}^2 = \text{aryl or alkyl group}$) at 80°C , the tetrazole derivative **981** was obtained.⁵⁴¹ Scheme 193.

Scheme 193. NIS mediate cyclization of propargylamines.

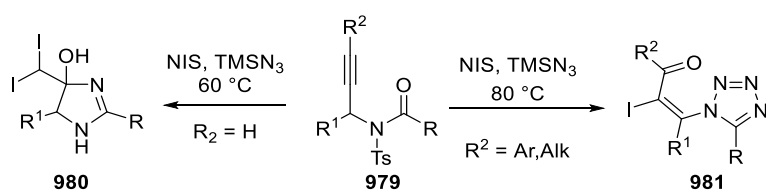

A series of interesting approaches to bicyclic nitrogen heterocycles from propargylamine derivatives are shown in Scheme 194. Sucunza *et al.* described the synthesis of imidazo[1,2-*a*]pyridines **983** from aryl-propargylamine **982** by treatment with isopentyl nitrite and CuCl₂,⁵⁴² whilst Ramesh *et al.* developed the synthesis of fused benzimidazolopyrazine derivatives **988** via a tandem benzimidazole formation/annulation of propargylamine **984**.⁵⁴³ Finally, purine-fused tricyclic compounds **990** were synthesized from propargyladenines **989** using CuBr as catalysts by Li *et al.*. When terminal alkynes were used as substrates (R = H), the compound **990** was obtained in good yields (78-88%). However, when R = Ar, a mixture of **991a** and **991b** was often observed, with overall yields ranging from 75-89%. In most cases, **991a** was obtained as the major product.⁵⁴⁴

Scheme 194. Synthesis of various polycyclic heterocycles

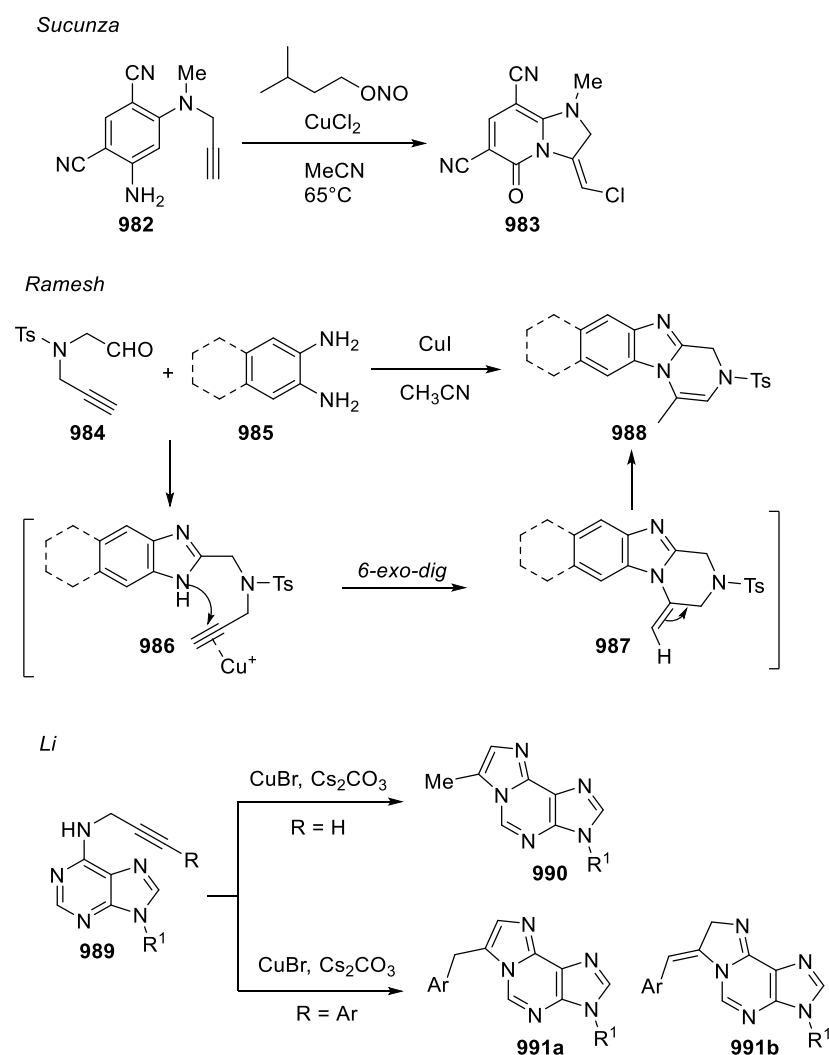

3.14 Various metal-catalyzed transformations of propargylamines substrates

Propargylamines can be used as substrates for the synthesis of a variety of important chemical compounds as shown in previous sections. In addition, propargylamines can undergo a variety of additional chemical reactions with different metal catalysts leading to a number of derivatives in turn available as substrates for the synthesis of more complex organic molecules. The following section will cover primarily the reaction of propargylamine substrates with palladium catalysts and their conversion into chemically or biologically relevant compounds. Additional metal catalyzed reactions will be also covered.

3.14.1 Palladium-catalyzed Sonogashira reactions of propargylamines. Since 1975, the Sonogashira coupling has been one of the most investigated palladium-catalyzed cross-coupling reactions in organic synthesis and has thus been frequently employed in the preparation of heterocycles, natural products, dendrimers, molecular wires and conjugated polymers.⁵⁴⁵⁻⁵⁴⁶ Propargylamines have been often used as substrates for Sonogashira-type reactions. In a classical approach, the palladium-catalyzed C–C bond forming process between the sp hybridized carbon of an alkyne and the sp^2 carbon of an aryl or vinyl halide (or triflate) is successfully achieved in the presence of copper iodide as co-catalyst and of a base (e.g. Et_3N , Et_2NH). An early example of a reaction between the propargylamine **992** and aryl iodides is reported by Gotteland *et al.*,⁵⁴⁷ in which the design of potential labelling agents for squalene epoxidase was reached through the straightforward coupling of a bisthienyl-propargylamine and appropriate phenylazides (Scheme 195).

Scheme 195. Sonogashira coupling of propargylamine 992 with aryl-iodides.

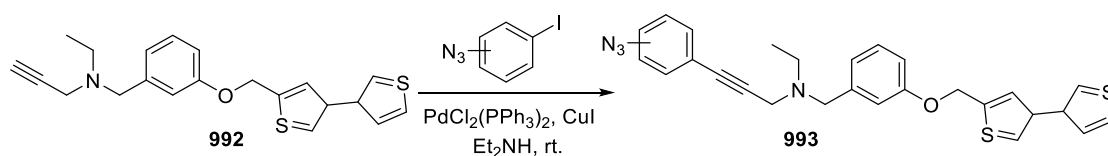

Similarly, the coupling of iodoarenes with propargylamines has been widely exploited by Conn *et al.* for the synthesis of SSAO inhibitors in a combinatorial fashion. In this case, the Sonogashira coupling was carried out in THF/TEA at room temperature with tetrakis(triphenylphosphine)palladium(0) and copper iodide as catalysts.⁵⁴⁸ Generally, the Sonogashira reaction is used to introduce a Boc-protected propargylamine substituent, which can then be converted to other functionalities *via* oxidation/reduction. The terminal alkyne can also be used in other Sonogashira couplings or alternatively react with amines to afford imines. Notably, acid chlorides can also be suitable for standard Sonogashira coupling for the

synthesis of heterocycles. As reported by Müller and co-workers, the Sonogashira coupling can be used to trigger the formation of ynones, which can cyclize to oxazoles⁵⁴⁹ and halopyrroles.²⁷²

Two contributions by Chaudhuri and Kundu demonstrate the versatile use of Sonogashira reactions for the synthesis of biologically-active compounds. The reaction of propargylamine derivative **994** with differently-substituted aryl iodides in the presence of $\text{PdCl}_2(\text{PPh}_3)_2$, CuI and Et_3N in acetonitrile/DMF mixtures has been shown to afford the desired disubstituted alkynes **995** in good yields (64–68%) Table 39.⁵⁵⁰ In a similar fashion, the authors broadened the scope of this reaction by employing a wider range of aryl iodides as substrates of the Sonogashira coupling.⁵⁵¹ As the presence of the copper iodide seemed to promote heteroannulation reactions, the authors also explored the reactivity of these disubstituted propargylamines **995** in the creation of benzo-fused heterocyclic systems **996** which contain one or more heteroatoms, *e.g.* benzoxazepin-5-ones, quinazolinones, and benzoxazines. Surprisingly, in the case of the benzoxazepine derivatives, the choice of acetonitrile as solvent allowed for the formation of the desired products in a highly regio- and stereoselective manner without the formation of side products.

Table 39. Sonogashira coupling and heteroannulation reactions of propargylamines 994.

Entry	Ar	R	X	Yield 995 (%)
1	Ph	Bn	ONa	68
2	p-MeOC ₆ H ₄	Bn	ONa	65

3	2,4-Dimethoxypyrimidin-5-yl	Bn	ONa	65
4	Ph	Me	NH- <i>p</i> -MePh	84
5	<i>o</i> -MeC ₆ H ₄	Me	NH- <i>p</i> -MePh	76
6	<i>o</i> -MeOC ₆ H ₄	Me	NH- <i>p</i> -MePh	70
7	<i>p</i> -MeOC ₆ H ₄	Me	NH- <i>p</i> -MePh	67
8	<i>o</i> -MeCO ₂ C ₆ H ₄	Me	NH- <i>p</i> -MePh	90
9	2-Thienyl	Me	NH- <i>p</i> -MePh	75
10	2,4-Dimethoxypyrimidin-5-yl	Bn	NH- <i>p</i> -MePh	79
11	<i>o</i> -MeC ₆ H ₄	Bn	NH- <i>p</i> -MePh	72
12	<i>p</i> -MeC ₆ H ₄	Bn	NH- <i>p</i> -MePh	65
13	<i>m</i> -Cl C ₆ H ₄	Bn	NH- <i>p</i> -MePh	67
14	<i>o</i> -MeCO ₂ C ₆ H ₄	Bn	NH- <i>p</i> -MePh	89
15	2-Thienyl	Bn	NH- <i>p</i> -MePh	73
16	2,4-Dimethoxypyrimidin-5-yl	Bn	NH- <i>p</i> -MePh	91

Taking inspiration from their previous work on palladium-catalyzed heteroannulation of vinylic compounds,⁵⁵²⁻⁵⁵³ the authors additionally explored the reactivity of derivatives **997** towards aryl iodides for the preparation of differently-substituted benzoxazines **1000**. Propargylamine **997** was reacted with a series of iodoarenes (Ar-I) and diiodoarenes (I-Ar-I) *via* a Sonogashira reaction to afford the corresponding alkynes **998** in good yields (72-96%). The consequent use of KOH as a base in an aqueous ethanolic solution promoted the

heteroannulation to afford the corresponding benzoxazines derivatives **1000**. The heteroannulation step occurs through a *6-exo-dig* attack of the phenoxide **999** on the triple bond resulting in the formation of the *Z* isomer in a highly stereoselective manner.⁵⁵⁴ Scheme 196.

Scheme 196. Sonogashira coupling-heteroannulation for the synthesis of benzoxazines 1000.

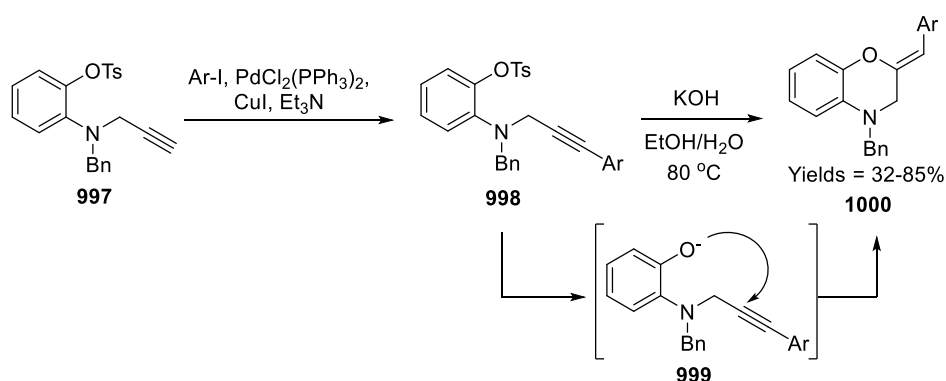

Sonogashira coupling reactions have been successfully exploited in the functionalization of nucleosides with propargylamines. An example of highly-regioselective C-5 iodination of a pyrimidine nucleoside and subsequent chemoselective Sonogashira coupling with propargylamine was recently reported by Kore and co-workers.⁵⁵⁵ The two-step reaction pathway that leads to 5-(3-aminopropargyl)-2'-deoxyuridine-5'-triphosphate (**1004a**, R = H) and 5-(3-aminopropargyl)-uridine-5'-triphosphate (**1004b**, R = OH) consists of the selective iodination reaction of the deoxyuridine and uridine nucleosides, using NIS and sodium azide in water. The classical palladium-catalyzed Sonogashira coupling of the 5-iodo-uridine derivative **1001** was performed in the presence of Pd(PPh₃)₄, CuI and a base, and led to the formation of the desired product **1002** in high yield (89%). Scheme 197. Notably, no formation of the Ullmann-Goldberg coupling product, i.e. coupling between the 5-iodo nucleoside and the amino group of the propargylamine, was registered under the investigated conditions. Furthermore, as opposed to what had been previously reported in the literature,⁵⁵⁶⁻

⁵⁵⁷ it appears that the authors' optimized route does not require the protection of the propargylamine for the reaction to proceed. In fact, previous contributions showed that 5-(3-aminopropargyl)-2'-deoxyuridine-5'-triphosphate could only be obtained through the reaction of 5-ethynyl-2'-deoxyuridine with trifluoroacetate-protected propargylamine. The protected nucleoside was then phosphorylated and the trifluoroacetate protecting group was successively removed with the use of a strong base, thus affording the propargylamino nucleotide.

Scheme 197. Functionalization of nucleosides with propargylamines via Sonogashira couplings.

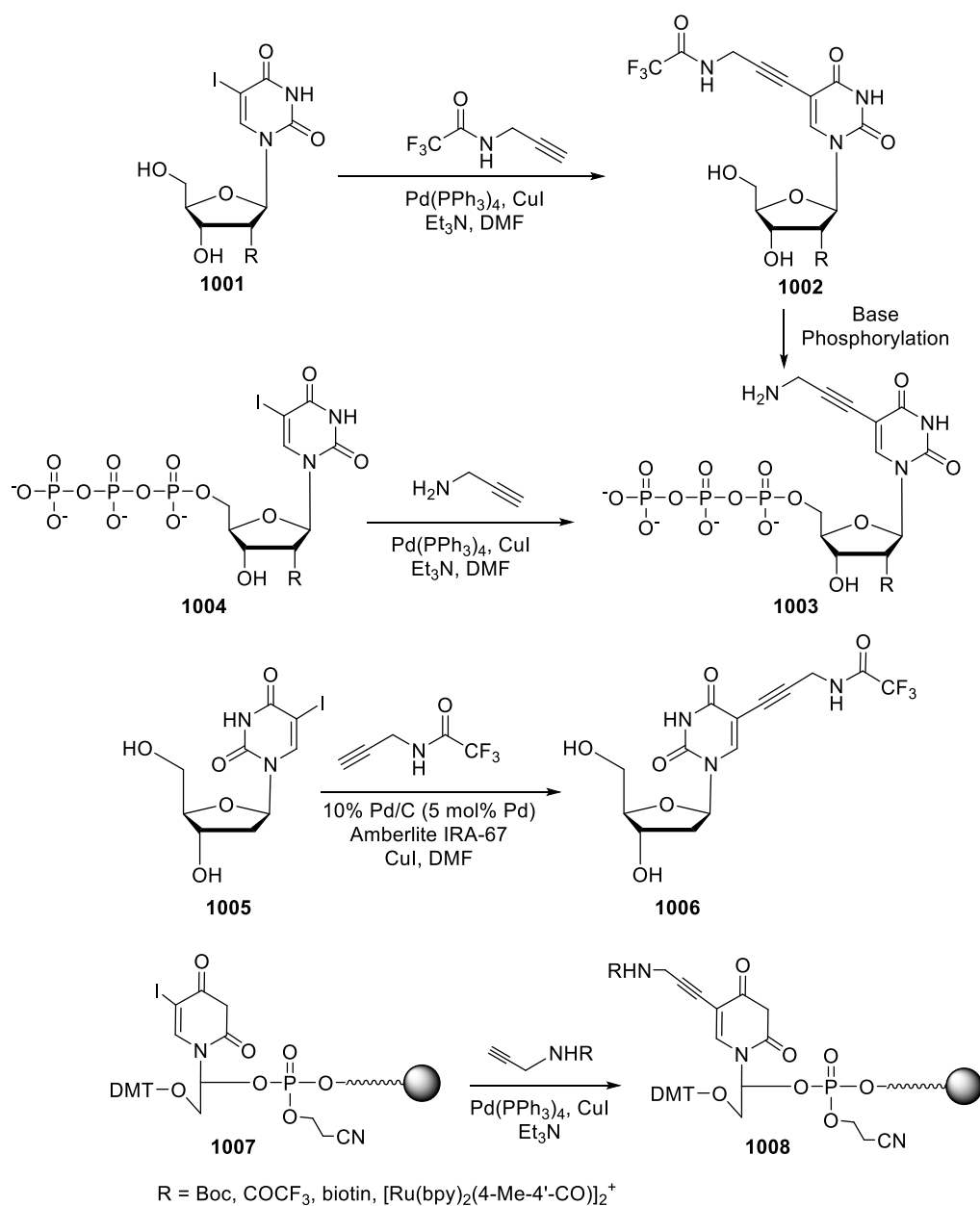

Following this approach, similar works on the functionalization of nucleotides with propargylamines have also been reported. A palladium on charcoal catalyst and a resin-bound tertiary amine (Amberlite IRA-67) were used to perform a copper-co-catalyzed coupling of *N*-protected propargylamines with halonucleosides (5-iodouracil, 5-iodocytosine, and 2-bromo-guanine). This methodology also allowed access to several biologically relevant

deoxynucleosides like **1006** in a straightforward manner with average to good yields (Scheme 197).⁵⁵⁸

In the past two decades, numerous reports have highlighted the potential benefits for the use of polymer supported reagents for solid-phase Sonogashira couplings with propargylamines.⁵⁵⁹⁻⁵⁷²

The versatility of the Sonogashira reaction was demonstrated by Khan and Grinstaff through the facile coupling of Boc- and COCF₃-protected propargylamines, propargylamino-derivatized biotin and transition metal propargylamine complex with solid-supported oligonucleotides (Scheme 197).⁵⁷³ Despite the intrinsic properties and the synthetic requirements of each of the propargylamine substrates, the derivatives **1008** were prepared in good yields. The Pd(0)-catalyzed Sonogashira coupling was carried out through combination of the substrates and the previously-prepared 5-iodo-substituted pyrimidine nucleoside analogue **1007**. Notably, neither the charge nor the striking chemical difference in the substrates affected the reactivity and the functionalization of the polymer, thus proving wide functional group tolerance and providing practical advantages in the reaction conditions and oligonucleotide purification.

In addition, the Sonogashira coupling reaction was extensively exploited to develop unsymmetrical linker-scaffolds **1011** for the solid-phase synthesis of dimeric pharmacophores. Starting from 3,5-diiido-4-methoxybenzene (DIMB) **1009**, the linker-scaffold systems were constructed *via* consequential Sonogashira reactions with *N*-protected propargylamines (*N*-Boc and *N*-Fmoc propargylamines) that could subsequently be orthogonally deprotected to achieve a wide library of heterosubstituted linkers **1011** (Scheme 198).⁵⁷⁴

Scheme 198. Synthesis of linker scaffolds via Sonogashira couplings.

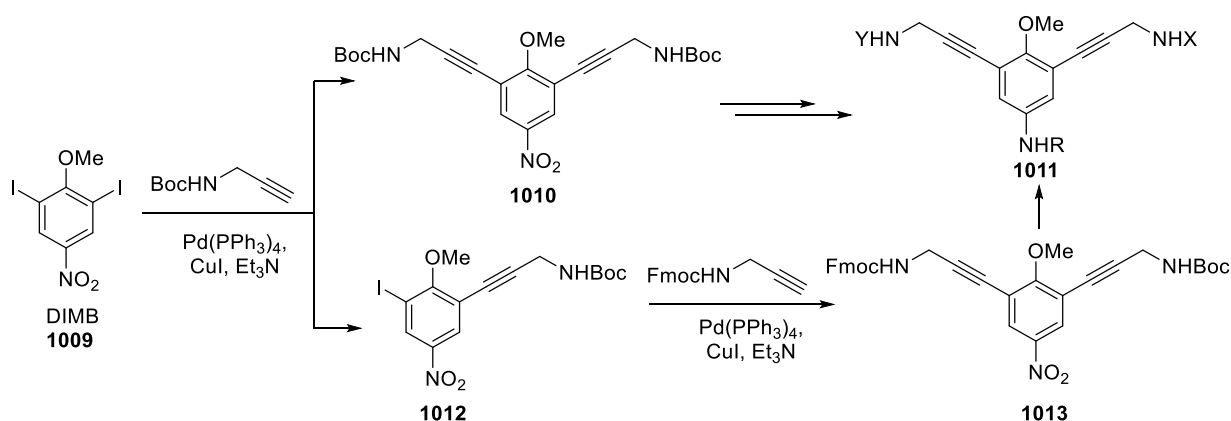

The Sonogashira reaction has also been widely employed for the preparation of enediynes. In view of their potent antitumor activity, enediynes have fostered the interest of researchers in the past two decades. Rawat and Zaleski reported symmetric and asymmetric nitrogen donor enediyne chelates that could undergo Bergman cyclization at variable temperatures.⁵⁷⁵ The strategy for the preparation of enediyne **1015** involved the coupling of 2.2 equivalents of *N*-dimethyl-propargylamine with *cis*-1,2-dichloroethylene over a Pd(0) catalyst in the presence of CuI and BuNH₂. This procedure allowed for the disubstituted enediyne **1015** to be obtained in high yield (79%). Similarly, the monosubstituted enediyne **1014** was obtained through the same reaction conditions, using a 1:1.2 molar ratio of the propargylamine and *cis*-1,2-dichloroethylene. Subsequently, the reaction of **1014** with *N*-Boc propargylamine and subsequent removal of the protective group generated the resulting monoamino product **1018**. The diamino enediyne product **1019** was then obtained by reacting two equivalents of *N*-Boc propargylamine with *cis*-1,2-dichloroethylene as reported in Scheme 199.

Scheme 199. Synthesis of enediyne **1017 and **1019** from propargylamines.**

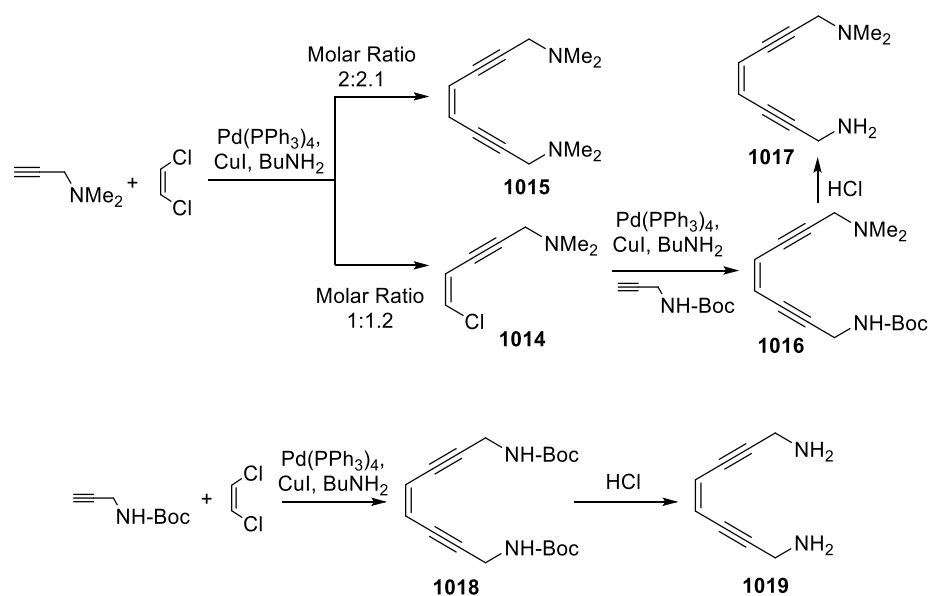

In another contribution, Yalagala *et al.* reported a Pd(II)- and Cu(I)-mediated homotrimerization reaction that was carried out by using *N*-Boc propargylamine.⁵⁷⁶ Although the Sonogashira reaction was performed in the presence of dihaloalkenes, it appeared that the trimerized product **1021** was obtained as the only product by using the *N*-protected propargylamine. Scheme 200. In a parallel work, the same authors discussed the reaction of *N*-Boc propargylamine with trisubstituted (*Z*)-bromoalkenyl-pinacolboronates **1022** in the presence of CuI , $\text{Pd}(\text{PPh}_3)_4$ and Hünig's base.⁵⁷⁷ When the reaction was carried out with one molar equivalent of *N*-Boc-propargylamine, the major product was found to be that of the Sonogashira coupling product **1024** alongside a homocoupling dimer from *N*-Boc-propargylamine. However, when the reaction was carried out with two molar equivalents of *N*-Boc-propargylamine, the formation of the trisubstituted aromatized product **1023** was confirmed by ^1H NMR. Further studies on the intermediates indicate that the aromatization product **1023** could arise from the cyclization of the Sonogashira coupling product **1024** in this process. Although low to moderate yields were found, these reactions allow access to a multitude of differently tetrasubstituted benzene derivatives. Scheme 200.

Scheme 200. Sonogashira couplings of propargylamines with dihaloalkenes and pinacolboronates.

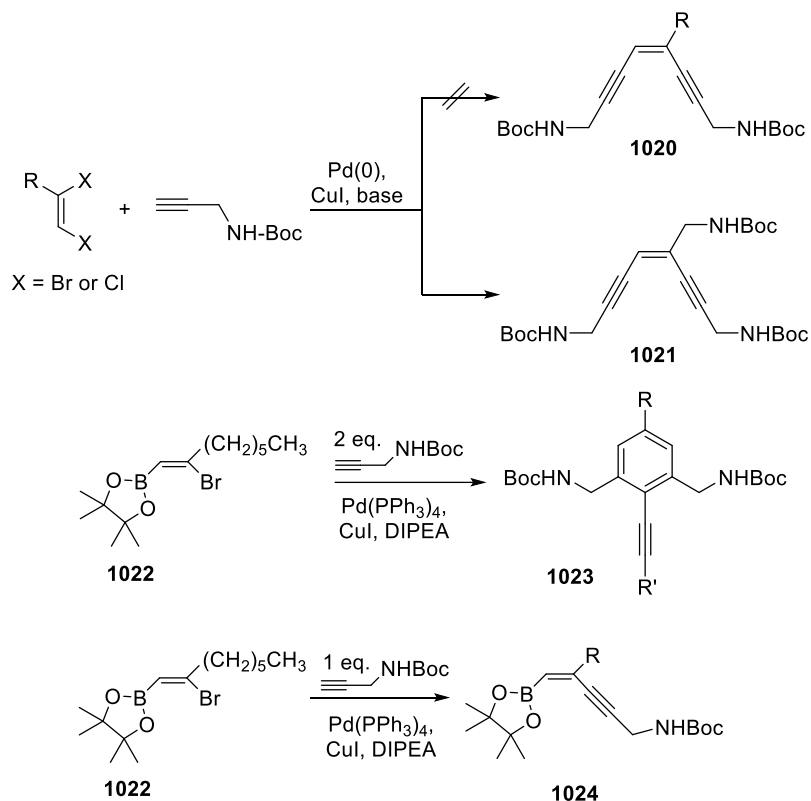

Classical Sonogashira coupling conditions were also employed for the synthesis of the macrocyclic metallocenediynes. In 2001, Zalenski and co-workers reported the synthesis of a series of cyclic enediynes as copper and zinc chelators.⁵⁷⁸ Finally, Zhang *et al.* in 2006 reported a copper- and amine-free Sonogashira reaction between aryl bromides and *N,N*-diethyl propargylamine (DEP) in the presence of aminophosphine ligands.⁵⁷⁹

3.14.2 Palladium catalyzed synthesis of allenes from propargylamines. In view of the interest in allenes as building blocks for organic chemistry, many efforts have been spent in recent years to develop new versatile methods for their synthesis. Among them, allenes can be obtained directly from propargylamines. Nakamura *et al.* reported a one-pot palladium-catalyzed transformation of propargylamines into allenes **1026**. Propargylamines can in fact be considered as allenyl anion equivalents that can react with electrophiles to afford

substituted allenes *via* hydrogen-transfer reactions.⁵⁸⁰ The authors first synthesized various propargylamines **1025** through Sonogashira coupling between several aryl iodides and propargylamines using Pd(PPh₃)₄, CuI and triethylamine (Table 40). The conversion of propargylamines into allenes through hydrogen-transfer reaction was subsequently investigated. Propargylamines **1025** were treated with Pd₂dba₃·CHCl₃/(C₆F₅)₃P in dioxane at 100 °C, leading to various allenes **1026** in good yields. The palladium-catalyzed hydrogen-transfer showed a good tolerance to the presence of both electron-donating and electron-withdrawing groups on the aromatic ring. In fact, highly-efficient hydrogen transfers on propargylic amines bearing electron-donating groups like AcNH and MeO were recorded, with the allenes being obtained in 74 and 99% yield respectively (*entries 3-4*). Similarly, a quantitative conversion to the corresponding allene was recorded in the case of electron-withdrawing groups (*entry 5*).

Table 40. Synthesis of allenes 1026.

Entry	R ¹	R ²	1025	1026
			Yield (%)	Yield (%)
1	Ph	Et	64	12
2	Ph	<i>i</i> -Pr	86	99
3	4-MeOC ₆ H ₄	<i>i</i> -Pr	95	99
4	4-(AcNH)C ₆ H ₄	<i>i</i> -Pr	89	74
5	4-(CO ₂ Et)C ₆ H ₄	<i>i</i> -Pr	99	96

Based on the same principle of anion equivalency, the same authors attempted to introduce allenic groups into the backbone of pharmacologically active molecules in order to produce

new pharmacological properties.⁵⁸¹ Allenic quinazolines **1029** were synthesized from the coupling of corresponding iodides **1027** and dicyclohexyl-propargylamine *via* Sonogashira/hydrogen-transfer reactions. Scheme 201.

Scheme 201. Synthesis of allenes from propargylamine derivatives 1028 and 1030.

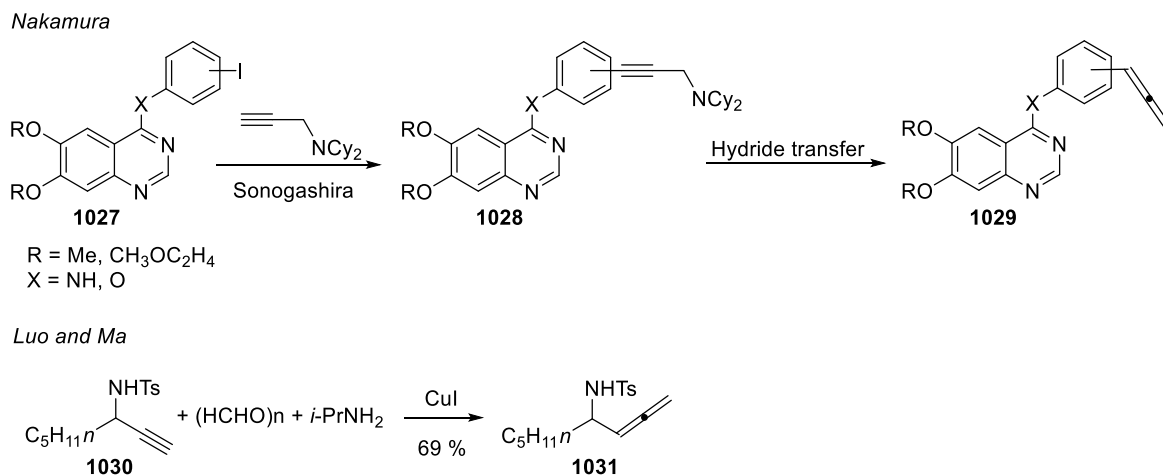

More recently, Luo and Ma used a protected propargylamine **1030** for the synthesis of allenes **1031**.⁵⁸² The *N*-tosyl propargylamine **1030** was reacted with *p*-formaldehyde and isopropylamine, in a Cu(I)-catalyzed A³ coupling reaction to afford the corresponding allenylamine in good yield (Scheme 201). Noteworthy, the reaction also proceeds when propargylamides are used, although lower yields were registered.

3.14.3 Other palladium-catalyzed reactions of propargylamines. Palladium-catalyzed intramolecular reactions are often advantageous for the preparation of highly-complex heterocycles that can often be found in biologically active and natural compounds. To achieve such highly-substituted heterocycles, the combination of palladium- and other metal-catalyzed reactions is sometimes required. In 2010, Van der Eycken reported the synthesis of 3-benzazepines **1034** in 63-91% yield through a two-step protocol consisting of a microwave-assisted Cu-catalyzed three-component coupling to provide the desired propargylamines **1033** followed by a regio- and stereoselective Pd-catalyzed intramolecular acetylene hydroarylation (Scheme 202).⁵⁸³ An array of aromatic and aliphatic alkynes and aldehydes

was successfully combined with various amines in the A^3 coupling reaction, which straightforwardly afforded the corresponding propargylamines **1033** in 73–95% yield. Additionally, a Cu(I)-catalyzed tandem anti-Markovnikov hydroamination and alkyne addition was also carried out. The key stage in the synthesis of 3-benzazepines **1034** was represented by the cyclization of the generated propargylamines **1033** through a palladium-catalyzed intramolecular acetylene hydroarylation, in the presence of $\text{Pd}(\text{PPh}_3)_4$ and HCOONa as the reducing agent. A plausible mechanism of this intramolecular cyclization is reported in Scheme 202. The *Z*-configuration of the exocyclic double bond is achieved through the *syn*-addition of the π -arylpalladium species **1035** to the triple bond, which results in the formation of the σ -vinyl palladium complex and subsequent cyclization. The regioselectivity of the hydroarylation reaction and the size of the benzazepine ring is determined by the *exo*-cyclization mechanism. In fact, as *endo*-cyclizations are highly unlikely, only 7- or 8-membered rings are formed ($n = 1$ or 2).

Scheme 202. Synthesis of 3-benzazepines via Pd-catalyzed intramolecular acetylene hydroarylation.

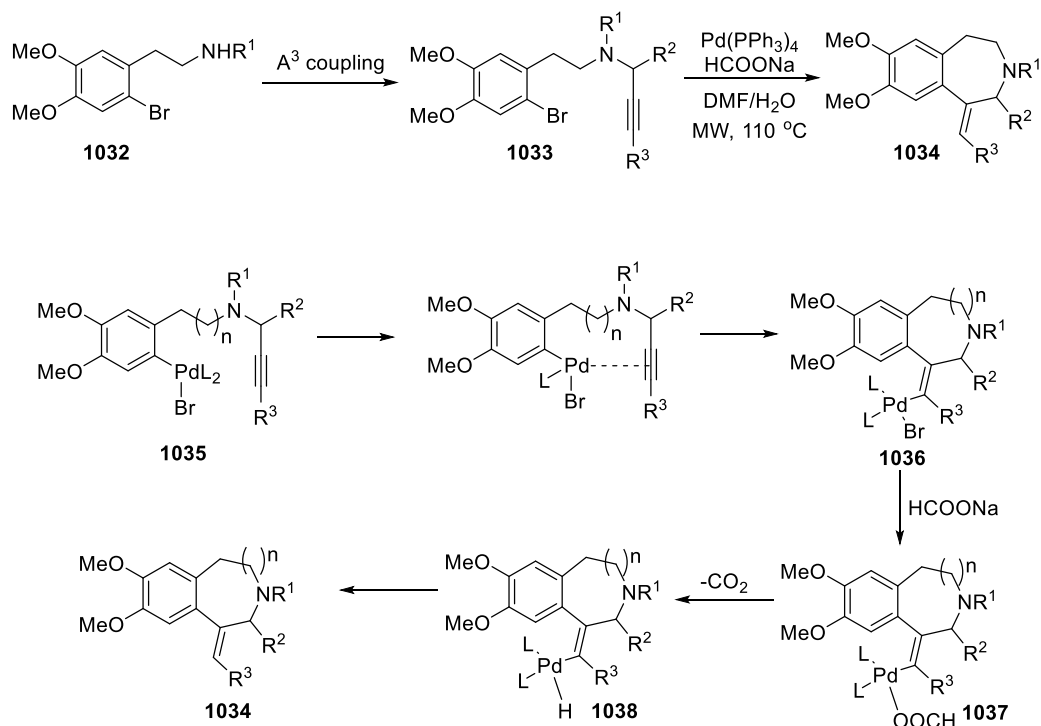

In a subsequent contribution from the same authors, 3-benzazepines were synthesized using a Heck-Suzuki tandem reaction. This methodology allowed for the substituents of the 3-benzazepine scaffold to be further diversified.⁵⁸⁴ Starting from the well-established A³ coupling reaction, which leads to the propargylamino-substrates, a tandem intramolecular cyclization and consequent functionalization of the resulting double bond is performed by reacting the resulting substrates with different organoboron reagents in the presence of Pd(PPh₃)₂Cl₂ and a base in a DMF/water mixture.

Propargylamines have also been employed as ligands for the preparation of palladacycle catalyst precursors. In 2003, Dupont and co-workers reported the chloropalladation of *N*-dimethyl-propargylamine for the preparation of a Pd(II) catalyst to be employed in phosphine-free Heck reactions.⁵⁸⁵

3.14.4 Metathesis reactions of propargylamines. Enyne metathesis reactions of propargylamines substrates have been widely reported in the literature. Most of these transformations are RCEYM reactions and lead to the formation of pyrrolines or tetrahydropyridines, as shown in section 3.2.1. However, additional approaches to convert propargylamines into chemically or biologically interesting compounds *via* enyne metathesis have been reported.

Diver's research group thoroughly investigated the enyne metathesis reaction and described the synthesis of 1,3-diene products from a variety of alkyne substrates.⁵⁸⁶ In 2000, Diver and Smulik reported the metathesis reaction of a propargylamine with ethylene at 60 psi to obtain the corresponding diene in 91% yield.⁵⁸⁷ Later, Castagnolo *et al.* reported the conversion of a series of propargylamines **1039** into the corresponding 1,3-diene derivatives **1040** through a microwave assisted cross metathesis reaction with gaseous ethylene. Dienes **1040** were obtained in good yields and in a few minutes.⁵⁸⁸ Later, the scope of the reaction was expanded and the diene product **1041** was used as a synthon for the synthesis of the antifungal agent bifonazol (*S*)-**1042**. A tandem enyne-olefin ring closing metathesis reaction was also carried out in order to develop a shorter synthetic pathway to bifonazole. Propargylamine **1043** was reacted with cyclooctadiene under microwave irradiation and converted into the cyclic diene **1044** in several minutes. Further oxidation with DDQ led to the aromatization of the cycle and then to the enantiomer bifonazole (*R*)-**1042** in a few steps.⁵⁸⁹ Scheme 203. In parallel, Castagnolo *et al.* also reported a multicomponent enyne metathesis – Diels-Alder reaction to access 2,3-dihydropyrans derivatives **1045** from a range of alkyne substrates, including *N*-Boc-propargylamine.⁵⁹⁰ Scheme 203.

Scheme 203. Enyne cross metathesis reactions of propargylamines.

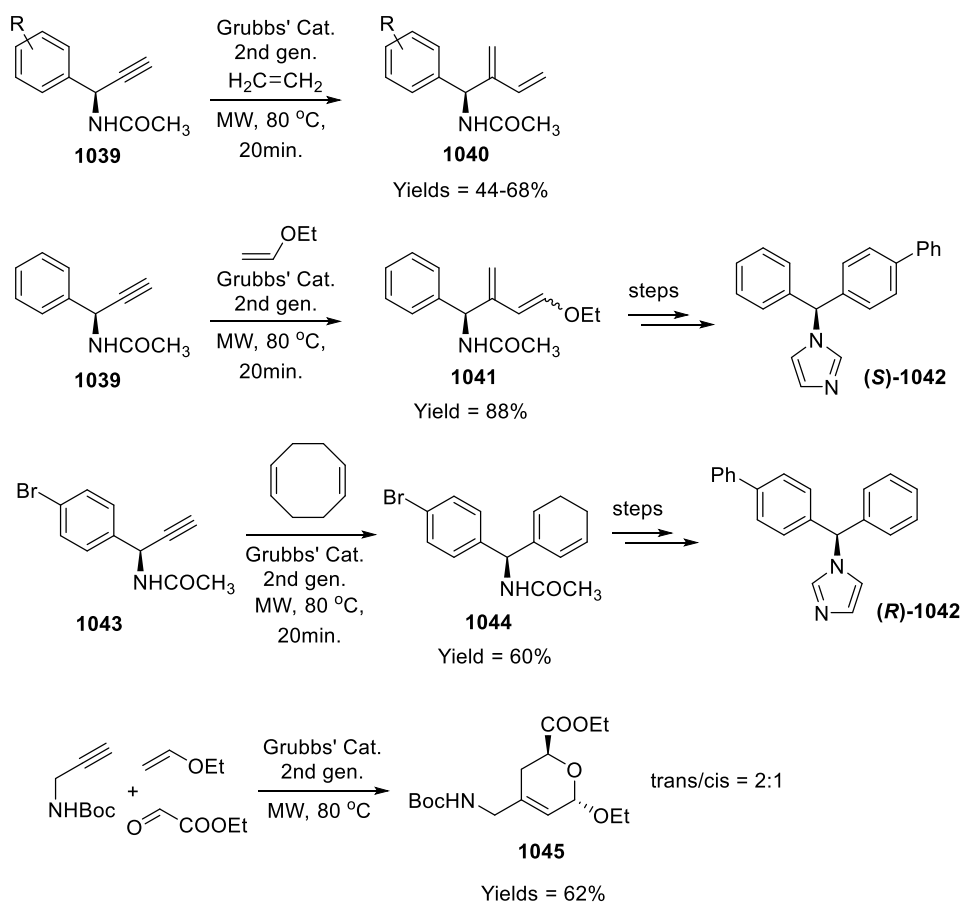

Propargylamine-containing synthons have been also used in enyne metathesis reactions for the synthesis of macrocycles and natural product mimetics as shown in the works of Barret,⁵⁹¹ Spring,⁵⁹²⁻⁵⁹³ Lee⁵⁹⁴ and Solé.⁵⁹⁵ Scheme 204. In all cases the enyne macrocyclization reaction was carried out with Grubb's catalyst 2nd gen. **GII**, leading to macrocycles in good yields. In the case of compounds **1051** and **1053**, the enynes **1050** and **1052** were first reacted with ethylene in the presence of **GII** to afford the enyne metathesis diene products. These latter were then further treated with **GII** leading to the desired macrocycles *via* an olefin ring closing metathesis.

Scheme 204. Enyne metathesis macrocyclization of propargylamine substrates.

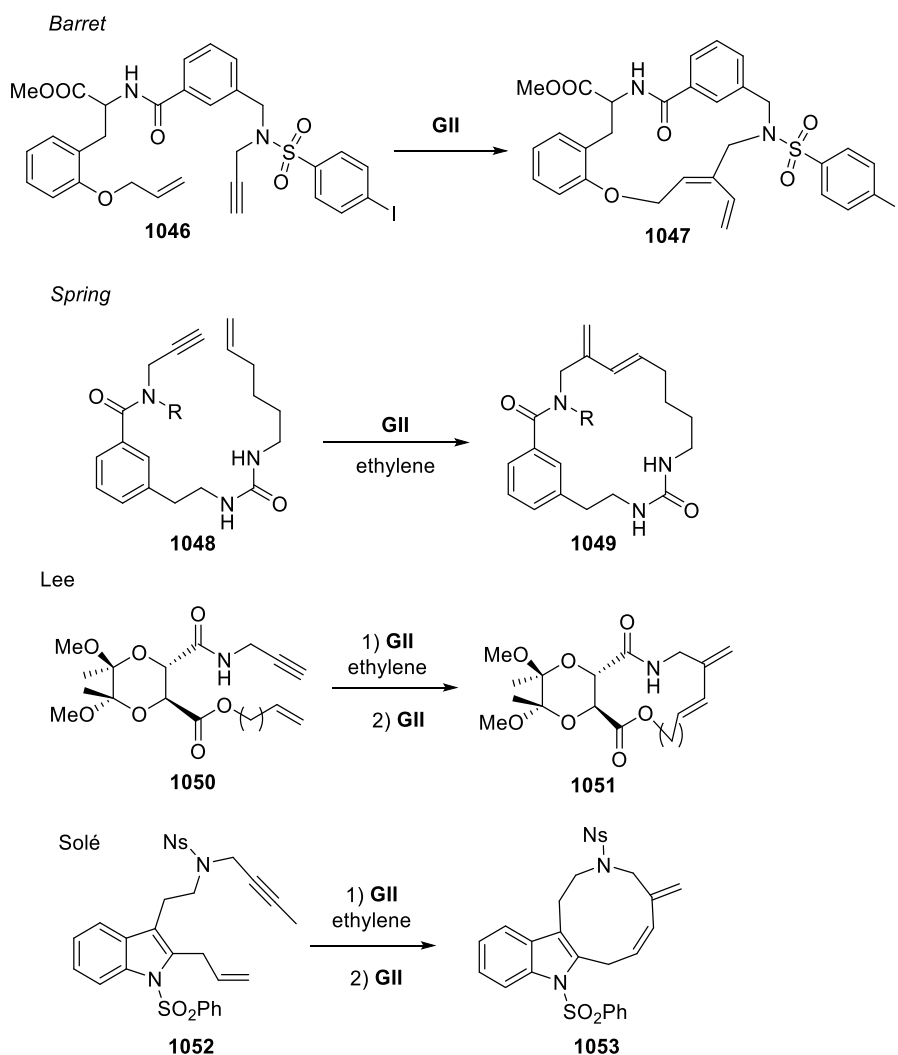

3.14.5 Cobalt and titanium catalyzed Pauson-Khand reactions of propargylamines.

The alkynyl group of propargylamines can be activated by a dicobalt carbonyl catalyst through μ -coordination in a Pauson-Khand reaction (PKR) fashion. Hong and co-workers carried out an interesting experimental and computational study on the reaction of unprotected propargylamines with various dicobalt carbonyl complexes, leading to the formation of differently propargylamine-bridged dicobalt complexes **1054-1055** by suitably tuning the reaction conditions and stoichiometry.⁵⁹⁶⁻⁵⁹⁷ Scheme 205.

Scheme 205. Synthesis of propargylamine-bridged dicobalt complexes.

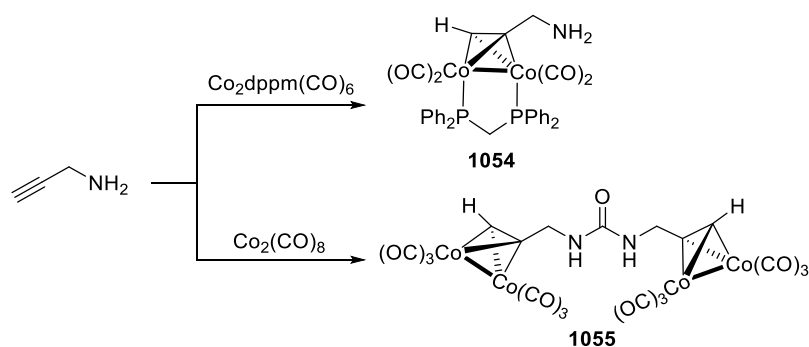

Later, Ji *et al.* showed that alkylated propargylamines can be successfully employed in PKR with norbornadiene (NBD) to obtain the cyclic enone **1059**.⁵⁹⁸ While the complexation of the unprotected and monomethylated propargylamine with the dicobaltoctacarbonyl catalyst occurred successfully to yield **1056**, the consequent PKR with NBD did not lead to the desired product **1057** under either stoichiometric nor catalytic conditions. In contrast, when the tertiary *N,N*-dimethyl-propargylamine was used, the PKR proceeded well, affording the expected PK product **1059** in 87% yield (Scheme 206). These results suggested that tertiary propargylamines are required to carry out a successful PKR.

Scheme 206. PKR of propargylamines with NBD.

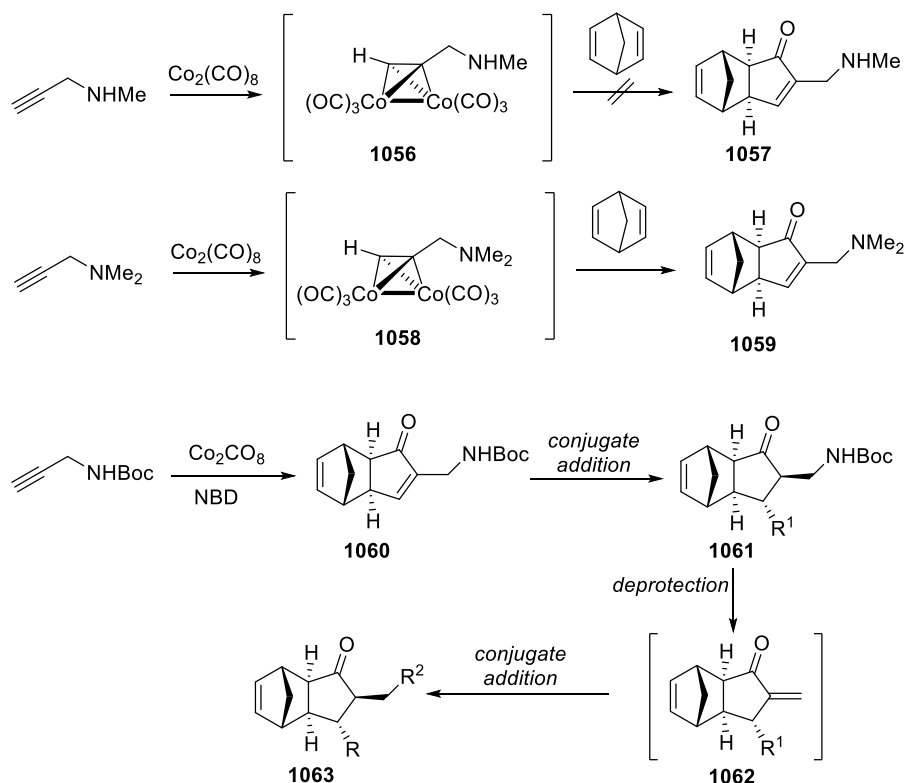

In view of these results, Aiguabella *et al.* reported a new methodology for the preparation of 4,5-disubstituted cyclopentenones **1063** from *N*-Boc-propargylamine.⁵⁹⁹ The strategy employed, which avoids the use of alkylating agents to functionalize a side chain on the α carbon, is based on a PKR using NBD as a masked enone and *N*-Boc-propargylamine as the alkyne source. Notably, this cobalt-catalyzed intermolecular reaction allowed the authors to afford the desired tricyclic compound **1060** in good to excellent yields. Conjugated additions of different nucleophiles on these PK adducts, removal of the Boc-protecting group, and subsequent conjugated additions afforded the corresponding cyclopentenones **1063** in good yields. As shown by the authors, the synthetic potential of this methodology relies on the enone-character of the NBD, which plays a key role in stereodirecting the conjugate addition to the cycloadducts (Scheme 206).

Interesting transformations of allyl-protected propargylamines **1064** were reported by Knochel and co-workers. Through a tandem Pauson-Khand/oxidation reaction, the authors were able to obtain the bicyclic compound **1065** as a single diastereoisomer in reasonable yields (Scheme 207).⁹¹

Scheme 207. PKRs of propargylamine 1064 and 1069.

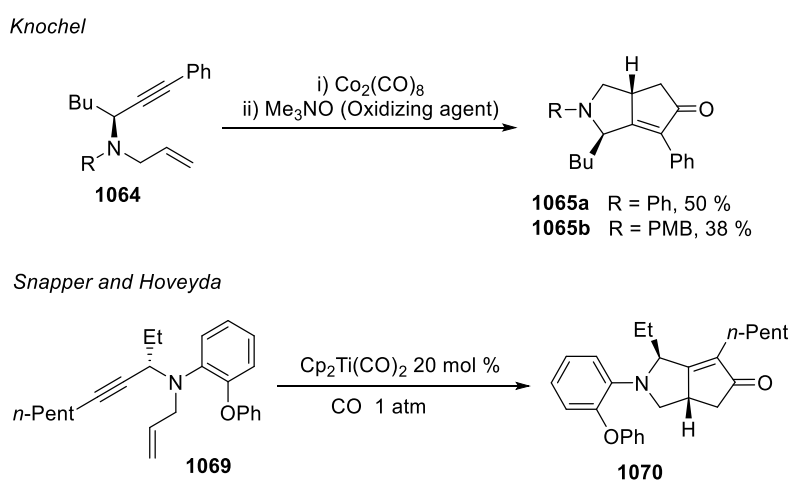

In addition to cobalt carbonyl compounds, titanium complexes have shown interesting properties as PKR catalysts using propargylamines. In 1999, Sturla and Buchwald reported a new methodology for asymmetric PKRs using various *N*-protected propargylamines.⁶⁰⁰ In this work, a titanium complex (**1068a** or **1068b**) was used to catalyze the cyclization of *N*-allyl propargylamines **1066** in the presence of CO to afford differently-substituted enones **1067** (Table 41). *N*-substituents with different electronic and steric properties were shown to have a reasonable effect on the substrate reactivity. As shown by the results, high levels of enantioselectivity can be achieved when electron rich and sterically-small nitrogen substituents are used.

Table 41. Titanium-catalyzed PKR of propargylamines 1066.

Reaction scheme showing the titanium-catalyzed PKR of propargylamine **1066** to form product **1067**. The reaction conditions are [Ti], 10 - 15 mol % and CO, 14 psig. The catalyst structures are defined as (S,S)-(EBTHI)Ti(CO)₂ L = CO **1068a** and (S,S)-(EBTHI)TiMe₂ L = Me **1068b**.

Entry	R ¹	R ²	ee (%)	Yield (%)
1	allyl	Ph	92	81
2	Bn	Me	92	82
3	Boc	Me	74	84
4	Ts	Me	31	83

Finally, taking inspiration by the pioneering work by Sturla and Buchwald, Snapper and Hoveyda later exploited a Ti-catalyzed intramolecular PKR starting from the allyl-protected propargylamine **1069** (Scheme 207).²³⁴ Compound **1070** was obtained with excellent yield (80%) when **1069** was treated with the titanium catalyst in the presence of 1 atm of CO.

4. CONCLUSIONS

Propargylamines represent an extremely interesting class of organic compounds that can be exploited as precursors and building blocks for the synthesis of a wide range of organic molecules, active pharmaceutical ingredients and polymers. The huge number of publications which continuously describe novel methods to synthesize and to derivatize propargylamine substrates account for their versatility and use in many fields of chemistry. Most of the methods for the synthesis of propargylamines rely on the metal catalyzed A³ coupling reactions. Nevertheless, in the last two decades, new approaches based on the metal-catalyzed

oxidative functionalization of tertiary amines and C-H and C-Hal functionalization have been discovered and developed and now represent robust and reliable synthetic methods. It is likely that in the near future additional and novel synthetic strategies, such as biocatalytic and greener approaches, will be developed to access this important class of compounds. Propargylamines also represent a privileged scaffold in the synthesis of many organic compounds, especially nitrogen heterocycles, due to their unique concurrent chemical properties which make them ideal reagents possessing both electrophilic and nucleophilic characteristics. It is certain that propargylamines will continue to attract the attention of many chemists and that improvements in their synthesis as well as novel transformations of these compounds will be reported in the literature in the near future.

AUTHOR INFORMATION

Corresponding Author

***E-mail** daniele.castagnolo@kcl.ac.uk

Biographies

Dr Daniele Castagnolo obtained his PhD in Pharmaceutical Sciences at the University of Siena (Italy) in 2006 working under the supervision of Professor Maurizio Botta on the synthesis of antimycobacterial agents and on the development of enyne metathesis reactions of propargylamine substrates. During his doctoral studies he joined the research group of Professor Johann Mulzer at the University of Vienna (Austria) as visiting PhD student. After completing his doctoral studies, he was appointed postdoctoral research associate at the Helsinki University of Technology (Finland) in the group of Professor Petri Pihko. In 2008 Daniele became Research Fellow at the University of Siena and later he moved to the

University of Manchester (UK) where he completed his postdoctoral studies working in the research group of Professor Jonathan Clayden. In 2012, Daniele started his independent research at Northumbria University Newcastle and later, in September 2015, he moved to King's College London where he is currently Lecturer of pharmaceutical chemistry. Dr Castagnolo's group interests are focused on the design and synthesis of novel antimicrobial agents and on the development of novel (bio)catalyzed reactions for the synthesis of drug-like compounds.

Kate Lauder obtained a first class honours in chemistry with biomedical science BSc (Hons) in 2015 at Northumbria University Newcastle (UK). Her degree included a year in industry as an industrial trainee, which was spent at Pfizer, Sandwich (UK), in the Analytical Research & Development (ARD) department. In October 2015, she started her PhD at King's College London under the supervision of Dr Castagnolo. Her research project focuses on the development of novel biocatalysts and biocatalytic reactions as a novel means of synthesising flavour compounds. The project is carried out in collaboration with Prozomix Ltd (industrial supervisor Dr. Simon Charnock).

Dr Anita Toscani obtained her MSci degree in Chemistry in 2011 at the University of Turin (Italy) where she studied cobalt carbonyl complexes as potential carbon monoxide releasing molecules (CO-RMs) under the supervision of Professor Roberto Gobetto. After spending a further year at the University of Turin in the group of Professor Claudia Barolo, she moved to Imperial College London (UK) to carry out a PhD focused on the study of multimetallic and nanoparticle assemblies for sensing applications, under the supervision of Dr James Wilton-Ely. Since October 2016, she is a postdoctoral research associate in the group of Dr Castagnolo at King's College London. In 2017, she has been awarded the prestigious C. W. Maplethorpe Fellowship in Pharmacy at King's College London.

Dr Nicolò Scalacci obtained a Master's Degree in Medicinal Chemistry at University of Siena (Italy), where he worked on a Master's thesis on the application of domino cyclohydroformylation reactions to the synthesis of natural products under the supervision of Professor Maurizio Taddei. In October 2013, he started his PhD at Northumbria University Newcastle (UK) working under the supervision of Dr Castagnolo on the synthesis of antimycobacterial agents and development of chemo-enzymatic reactions for the synthesis of pyrroles and thiazoles from propargylamine precursors. In 2015, Nicolò moved, together with Dr Castagnolo, to King's College London where he successfully completed his doctoral studies in April 2017.

ACKNOWLEDGMENTS

KL and DC acknowledge BBSRC for PhD Studentship funding. DC and AT acknowledges C. W. Maplethorpe Fellowship for funding. NS and DC acknowledge Northumbria University Newcastle for PhD funding.

ABBREVIATIONS

ω -TA	ω -transaminases
(+)-QUINAP	(R)-(+)-1-(2-phosphino-1-naphthyl)phthalazinamine
[bmim]PF ₆	1-butyl-3-methylimidazolium hexafluorophosphate
A ³ coupling	three-component coupling of an aldehyde, alkyne, and amine
Ac	acetyl
AIBN	azobisisobutyronitrile

AlaDH	alanine dehydrogenase
API	active pharmaceutical ingredient
Ar	aryl
AspRedAm	reductive aminase from <i>Aspergillus oryzae</i>
BINOL	1,1'-bi-2-naphthol
BIPHEP	2,2'-bis(diphenylphosphino)-1,1'-biphenyl
Bn	benzyl
Boc	<i>tert</i> -butoxycarbonyl
Bu	butyl
Bz	benzoyl
CAL-B	<i>Candida antarctica</i> lipase B
Cbz	carboxybenzyl
CCC	cyclization-carbonylation-cyclization
COD	1,5-cyclooctadiene
DABCO	1,4-diazabicyclo[2.2.2]octane
DCM	dichloromethane
DDQ	2,3-dichloro-5,6-dicyanobenzoquinone

DEAD	diethyl azodicarboxylate
DEP	diethyl propargylamine
DFT	density functional theory
DIMB	3,5-diiiodo-4-methoxybenzene
DIPEA	<i>N,N</i> -Diisopropylethylamine
DMAP	4-(dimethylamino)pyridine
DME	dimethylether
DMSO	dimethylsulfoxide
dr	diastereoisomeric ratio
EDCI	1-ethyl-3-(3-dimethylaminopropyl)carbodiimide
EYCM	enyne cross-metathesis
ee	enantiomeric excess
EVE	ethyl vinyl ether
Hal	halogen
HFIP	hexafluoroisopropanol
KA ²	three-component coupling of a ketone, amine, and alkyne
KR	kinetic resolution

LDA	lithium diisopropylamide
LDH-AuCl ₄	layered double hydroxide-supported gold tetrachloride
LSD1	lysine specific demethylase 1
MAO-B	monoamine oxidase B
MCM-41	mobil Composition of Matter No. 41
Me	methyl
MM K-10	montmorillonite K-10
MNP@PILAu	poly(ionic liquid)-coated magnetic nanoparticles
MOFs	metal–organic frameworks
MW	microwave irradiation
NADPH	dihyronicotinamide-adenine dinucleotide phosphate
NAP-MgO	nano Active™ Magnesium Oxide Plus
NBD	norbornadiene
NBS	<i>N</i> -bromosuccinimide
NCS	<i>N</i> -chloro succinimide
NHC	<i>N</i> -heterocyclic carbene
NIS	<i>N</i> -iodo succinimide

NP	nanoparticle
PTSA	<i>p</i> -toluenesulfonic acid
PIDA	phenyliodine(III)diacetate
PINAP	4-[2-(diphenylphosphino)-1-naphthalenyl]-N-[(R)-1-phenylethoxy]phthalazine
pip	(2-picolyliminomethyl)pyrrole anion
PK	Pauson-Khand
PKR	Pauson-Khand reaction
PMP	<i>p</i> -methoxyphenyl
PPA	polyphosphoric acid
Pr	propyl
Py	pyridine
PyBOX	bis(oxazoliny)pyridyl
RCEYM	ring-closing enyne metathesis
ROM	ring-opening metathesis
SSAO	semicarbazide-sensitive amine oxidase
s-factor	selectivity factor

TBHP	tert-butyl hydroperoxide
TFA	trifluoroacetic acid
THF	tetrahydrofuran
THP	tetrahydropyridines
TMG	1,1,3,3-tetramethylguanidine
Ts	<i>p</i> -toluenesulfonyl
10- <i>R</i> -9-BBDs	10-substituted-9-borabicyclo[3.3.2]decane

REFERENCES

- (1) Langston, J. W.; Irwin, I.; Langston, E. B.; Forno, L. S. Pargyline prevents MPTP-induced parkinsonism in primates. *Science* **1984**, 225, 1480-1482.
- (2) Chen, J. J.; Swope, D. M. Clinical pharmacology of rasagiline: a novel, second-generation propargylamine for the treatment of Parkinson disease. *J. Clin. Pharmacol.* **2005**, 45, 878–894.
- (3) Birks, J.; Flicker, L. Selegiline for Alzheimer’s disease. *Cochrane Database Syst. Rev.* **2003**, 1, CD000442.
- (4) Baranyi, M.; Porceddu, P. F.; Göloncsér, F.; Kulcsár, S.; Otrokocsi, L.; Kittel, Á.; Pinna, A.; Frau, L.; Huleatt, P. B.; Khoo, M.-L.; Chai, C. L. L.; Dunkel, P.; Mátyus, P.; Morelli M.; Sperlágh, B. Novel (hetero)arylalkenyl propargylamine compounds are protective in toxin-induced models of Parkinson’s disease. *Mol. Neurodegener.* **2016**, 11, 1-21.

- (5) Bolea, I.; Gella, A.; Unzeta, M. Propargylamine-derived multitarget-directed ligands: fighting Alzheimer's disease with monoamine oxidase inhibitors. *J. Neural. Transm.* **2013**, *120*, 893-902.
- (6) Zindo, F. T.; Joubert, J.; Malan, S. F. Propargylamine as functional moiety in the design of multifunctional drugs for neurodegenerative disorders: MAO inhibition and beyond. *Future Med. Chem.* **2015**, *7*, 609-629.
- (7) Boulton, A. A.; Davis, B. A.; Durden, D. A.; Dyck, L. E.; Juorio, A. V.; Li, X.-M.; Paterson, I. A.; Yu, P. H. Aliphatic propargylamines: new antiapoptotic drugs. *Drug Dev. Res.* **1997**, *42*, 150-156.
- (8) Bar-Am, O.; Amit, T.; Weinreb, O.; Youdim, M. B.; Mandel, S. Propargylamine containing compounds as modulators of proteolytic cleavage of amyloid-beta protein precursor: involvement of MAPK and PKC activation. *J. Alzheimers Dis.* **2010**, *21*, 361-371.
- (9) Mao, F.; Li, J.; Wei, H.; Huang, L.; Li, X. Tacrine-propargylamine derivatives with improved acetylcholinesterase inhibitory activity and lower hepatotoxicity as a potential lead compound for the treatment of Alzheimer's disease. *J. Enzyme Inhib. Med. Chem.* **2015**, *30*, 995-1001.
- (10) Marco-Contelles, J.; Unzeta, M.; Bolea, I.; Esteban, G.; Ramsay, R. R.; Romero, A.; Martínez-Murillo, R.; Carreiras, M. C.; Ismaili, L. ASS234, As a new multi-target directed propargylamine for Alzheimer's disease therapy. *Front. Neurosci.* **2016**, *10*, 294.
- (11) Özgeriş, B.; Aksu, K.; Tümer, F.; Göksu, S. Synthesis of dopamine, rotigotin, ladostigil, rasagiline analogues 2-amino-4,5,6-trimethoxyindane, 1-amino-5,6,7-trimethoxyindane, and their sulfamide derivatives. *Synth. Commun.* **2015**, *45*, 78-85.
- (12) Coqueron, P.-Y.; Didier, C.; Ciufolini, M. A. Iterative oxazole assembly via α -chloroglycinates: total synthesis of (-)-muscoride A. *Angew. Chem., Int. Ed. Engl.* **2003**, *42*, 1411-1414.

- (13) Ermolatev, D. S.; Bariwal, J. B.; Steenackers, H. P. L.; De Keersmaecker, S. C. J.; Van der Eycken, E. V. Concise and diversity-oriented route toward polysubstituted 2-aminoimidazole alkaloids and their analogues. *Angew. Chem., Int. Ed. Engl.* **2010**, *49*, 9465-9468.
- (14) Arshadi, S.; Vessally, E.; Edjlali, L.; Hosseinzadeh-Khanmiri, R.; Ghorbani-Kalhor, R. *N*-Propargylamines: versatile building blocks in the construction of thiazole cores. *Beilstein J. Org. Chem.* **2017**, *13*, 625–638.
- (15) Zhao, X.-B.; Ha, W.; Jiang, K.; Chen, J.; Yang, J.-L.; Shi, Y.-P. Efficient synthesis of camptothecin propargylamine derivatives in water catalyzed by macroporous adsorption resin-supported gold nanoparticles. *Green Chem.* **2017**, *19*, 1399-1406.
- (16) Shachat, N.; Bagnell, J. J. Reactions of propargyl alcohols and propargylamines with isocyanates. *J. Org. Chem.* **1963**, *28*, 991–995.
- (17) Easton, N. R.; Cassady, D. R.; Dillard, R. D. Acetylenic Amines. V. Morpholines from substituted *N*-(2-hydroxyalkyl)- propargylamines. *J. Org. Chem.* **1963**, *28*, 448–453.
- (18) Dillard, R. D.; Easton, N. R. Acetylenic amines. X. piperazines from substituted *N*-(2-hydroxyalkyl)propargylamines. *J. Org. Chem.* **1964**, *29*, 2464–2467.
- (19) Trost, B.; Li, C.-J. Modern alkyne chemistry, Wiley-VCH Verlag GmbH & Co, **2014**.
- (20) Mao, F.; Li, J.; Wei, H.; Huang, L.; Li, X. Tacrine–propargylamine derivatives with improved acetylcholinesterase inhibitory activity and lower hepatotoxicity as a potential lead compound for the treatment of Alzheimer’s disease. *J. Enzym. Inhib. Med. Chem.* **2015**, *30*, 995-1001.
- (21) Kopka, I. E.; Fataftah, Z. A.; Rathke, M. W. Preparation of a series of highly hindered secondary amines, including bis(triethylcarbinyl)amine. *J. Org. Chem.* **1980**, *45*, 4616–4622.
- (22) Hennion, G. F.; Hanzel, R. S. The alkylation of amines with t-acetylenic chlorides. Preparation of sterically hindered amines. *J. Am. Chem. Soc.* **1960**, *82*, 4908-4912.

- (23) Czernecki, S.; Valéry, J.-M. A stereocontrolled synthesis of a lincosamine precursor. *J. Carbohydr. Chem.* **1990**, *9*, 767–770.
- (24) Huleatt, P. B.; Khoo, M. L.; Chua, Y. Y.; Tan, T. W.; Liew, R. S.; Balogh, B.; Deme, R.; Göllöncsér, F.; Magyar, K.; Sheela, D. P.; Ho, H. K.; Sperlág, B.; Mátyus, P.; Chai, C. L. L. Novel arylalkenylpropargylamines as neuroprotective, potent, and selective monoamine oxidase b inhibitors for the treatment of Parkinson's disease. *J. Med. Chem.* **2015**, *58*, 1400-1419.
- (25) Schmitt, M. L.; Hauser, A.-T.; Carlino, L.; Pippel, M.; Schulz-Fincke, J.; Metzger, E.; Willmann, D.; Yiu, T.; Barton, M.; Schüle, R.; Sippl, W.; Jung, M. Non-peptidic propargylamines as inhibitors of lysine specific demethylase 1 (LSD1) with cellular activity. *J. Med. Chem.* **2013**, *56*, 7334-7342.
- (26) Abdel-Magid, A. F.; Carson, K. G.; Harris, B. D.; Maryanoff, C. A.; Shah, R. D. Reductive amination of aldehydes and ketones with sodium triacetoxyborohydride. Studies on direct and indirect reductive amination procedures. *J. Org. Chem.* **1996**, *61*, 3849–3862.
- (27) Zani, L.; Bolm, C. Direct addition of alkynes to imines and related C=N electrophiles: a convenient access to propargylamines. *Chem. Commun.* **2006**, 4263-4275.
- (28) Li, C.-J. The development of catalytic nucleophilic additions of terminal alkynes in water. *Acc. Chem. Res.* **2010**, *43*, 581-590.
- (29) Peshkov, V. A.; Pereshivko, O. P.; Van der Eycken, E. V. A walk around the A³-coupling. *Chem. Soc. Rev.* **2012**, *41*, 3790-3807.
- (30) Rodrigues, K. E.; Basha, A.; Summers, J. B.; Brooks, D. W. Addition of aryllithium compounds to oxime ethers. *Tetrahedron Lett.* **1988**, *29*, 3455–3458.
- (31) Merino, P.; Anoro, S.; Castillo, E.; Merchan, F.; Tejero, T. Direct vinylation and ethynylation of nitrones. Stereodivergent synthesis of allyl and propargyl amines. *Tetrahedron: Asymm.* **1996**, *7*, 1887-1890.

- (32) Merino, P.; Franco, S.; Gascon, J. M.; Merchan, F. L.; Tejero, T. Highly diastereoselective nucleophilic addition of organometallic reagents to 2-pyrrolidinyl nitrones: a semiempirical approach. *Tetrahedron: Asymmetry* **1999**, *10*, 1867-1871.
- (33) Ullrich, T.; Sulek, P.; Binder, D.; Pyerin, M. A new route to 4-ethynyl-*N*-hydroxy-2-imidazolidinones *via* oxime addition. *Tetrahedron* **2000**, *56*, 3697-3701.
- (34) Osipov, S. N.; Golubev, A. S.; Sewald, N.; Burger, K. New efficient syntheses of α -difluoromethyl- and α -trifluoromethyl-ornithine. *Tetrahedron Letts.* **1997**, *38*, 5965-5966.
- (35) Moroni, M.; Kokschi, B.; Osipov, S. N.; Crucianelli, M.; Frigerio, M.; Bravo, P.; Burger, K. First synthesis of totally orthogonal protected α -(trifluoromethyl)- and α -(difluoromethyl)arginines. *J. Org. Chem.* **2001**, *66*, 130-133.
- (36) Sémeril, D.; Le Nôtre, J.; Bruneau, C.; Dixneuf, P. H.; Kolomietsb, A. F.; Osipov, S. N. Fluorine-containing *a*-alkynyl amino esters and access to a new family of 3,4-dehydroproline analogues. *New J. Chem.* **2001**, *25*, 16-18.
- (37) Guillaume Magueur, G.; Crousse, B.; Bonnet-Delpon, D. Stereoselective access to substituted [(*E*)- or (*Z*)-1-(trifluoromethyl)allyl]amines. *Eur. J. Org. Chem.* **2008**, *10*, 1527-1534.
- (38) Chen, H.; Yu, W.; Guo, X. H.; Meng, W. D.; Huang, Y. G. Facile synthesis of α -difluoromethyl α -propargylamines from CF₂H-substituted *N-tert*-butanesulfinyl ketimines. *Chinese Chem. Lett.* **2012**, *23*, 277-280.
- (39) Aubrecht, K. B.; Winemiller, M. D.; Collum, D. B. BF₃-Mediated addition of lithium phenylacetylide to an imine: correlations of structures and reactivities. BF₃·R₃N derivatives as substitutes for BF₃·Et₂O. *J. Am. Chem. Soc.* **2000**, *122*, 11084-11089.
- (40) Ma, Y.; Lobkovsky, E.; Collum, D. B. BF₃-Mediated additions of organolithiums to ketimines: X-ray crystal structures of BF₃-ketimine complexes *J. Org. Chem.*, **2005**, *70*, 2335-2337.

- (41) Wee, A. G. H.; Zhang, B. Nucleophilic alkynylation of *N*-bis(trimethylsilyl)methyl aldimines. *Tetrahedron Lett.* **2007**, *48*, 4135–4138.
- (42) Katritzky, A. R.; Yang, H.; Singh, S. K. Preparation of tertiary alkyl carbinamines, propargylamines and α -heteroarylamines by ketone-based aminoalkylation. *J. Org. Chem.* **2005**, *70*, 286-290.
- (43) Qi, R.; Wang, X.-N.; DeKorver, K. A.; Tang, Y.; Wang, C. C.; Li, Q.; Li, H.; Lv, M. C.; Yu, Q.; Hsung, R. P. A convenient synthesis of γ -amino-ynamides *via* additions of lithiated ynamides to aryl imines; observation of an aza-Meyer-Schuster rearrangement. *Synthesis* **2013**, *45*, 1749–1758.
- (44) Xiao, K.-J. Wang, A.-E.; Huang, P.-Q. Direct transformation of secondary amides into secondary amines: triflic anhydride activated reductive alkylation. *Angew. Chem., Int. Ed.* **2012**, *51*, 8314-8317.
- (45) Huang, P.-Q.; Huang, Y.-H.; Xiao, K.-J.; Wang, Y.; Xia, X. E. A general method for the one-pot reductive functionalization of secondary amides. *J. Org. Chem.* **2015**, *80*, 2861–2868.
- (46) Dindulkar, S. D.; Kwan, B.; Lim, K. T.; Jeong, Y. T. An eco-sustainable green approach for the synthesis of propargylamines using LiOTf as a reusable catalyst under solvent-free condition *J. Chem. Sci.* **2013**, *125*, 101–107.
- (47) Liu, G.; Cogan, D.; Ellman, J. A. Catalytic asymmetric synthesis of tert-butanesulfinamide. Application to the asymmetric synthesis of amines. *J. Am. Chem. Soc.* **1997**, *119*, 9913-9914.
- (48) Ellman, J. A.; Owens, T. D.; Tang, T. P. *N*-tert-butanesulfinyl imines: versatile intermediates for the asymmetric synthesis of amines. *Acc. Chem. Res.* **2002**, *35*, 984-995.

- (49) Ding, C.-H.; Chen, D.-D.; Luo, Z.-B.; Daia, L.-X.; Hou, X.-L. Highly diastereoselective synthesis of *N*-tert-butylsulfinylpropargylamines through direct addition of alkynes to *N*-tert-butanesulfinimines. *Synlett*, **2006**, 1272-1274.
- (50) Harried, S. S.; Croghan, M. D.; Kaller, M. R.; Lopez, P.; Zhong, W.; Hungate, R.; Reider, P. J. Stereoselective synthesis of anti-*N*-protected 3-amino-1,2-epoxides by nucleophilic addition to *N*-tert-butanesulfinyl imine of a glyceraldehyde synthon *J. Org. Chem.* **2009**, *74*, 5975–5982.
- (51) Patterson, A. W.; Ellman, J. A. Asymmetric synthesis of α,α -dibranched propargylamines by acetylide additions to *N*-tert-butanesulfinyl ketimines. *J. Org. Chem.* **2006**, *71*, 7110-7112.
- (52) Xu, H.; Chowdhury, S.; Ellman, J. A. Asymmetric synthesis of amines using *tert*-butanesulfinamide. *Nat. Protoc.* **2013**, *8*, 2271–2280.
- (53) Díez, R.; Badorrey, R.; Díaz-de-Villegas, M. D.; Gálvez, J. A. Highly stereoselective synthesis of stereochemically defined polyhydroxylated propargylamines by alkynylation of *N*-benzylimines derived from (R)-glyceraldehyde. *Eur. J. Org. Chem.* **2007**, 2114–2120.
- (54) Kaur, P.; Shakya, G.; Sun, H.; Pan, Y.; Li, G. Chiral *N*-phosponyl imine chemistry: an efficient asymmetric synthesis of chiral *N*-phosponyl propargylamines. *Org. Biomol. Chem.* **2010**, *8*, 1091–1096.
- (55) Verrier, C.; Carret, S.; Poisson, J.-P. Asymmetric addition of alkoxy ethynyl anion to chiral *N*-sulfinyl imines. *Org. Lett.* **2012**, *14*, 5122–5125.
- (56) Jordan, S.; Starks, S. A.; Whatley, M. F.; Turlington, M. Highly stereoselective synthesis of terminal chloro-substituted propargylamines and further functionalization. *Org. Lett.* **2015**, *17*, 4842–4845.

- (57) Jäkel, M.; Qu, J.; Schnitzer, T.; Helmchen, G. Addition of organometallic reagents to chiral *N*-methoxylactams: enantioselective syntheses of pyrrolidines and piperidines. *Chem. Eur. J.* **2013**, *19*, 16746-16755.
- (58) Burger, K.; Sewald, N. α -Trifluoromethyl-substituted amino acids with acetylene groups in the side chain. *Synthesis* **1990**, 115–118.
- (59) Crucianelli, M.; De Angelis, F.; Lazzaro, F.; Malpezzi, L.; Volonterio, A.; Zanda, M. Synthesis of enantiomerically pure α -ethyl, α -vinyl and α -ethynyl 3,3,3-trifluoro alaninates. *J. Fluorine Chem.* **2004**, *125*, 573–577.
- (60) Kuduk, S. D.; DiPardo, R. M.; Chang, R. K.; Ng, C.; Bock, M. G. Reversal of diastereoselection in the addition of Grignard reagents to chiral 2-pyridyl *tert*-butyl (Ellman) sulfinimines. *Tetrahedron Lett.* **2004**, *45*, 6641–6643.
- (61) Chen, B.-L.; Wang, B.; Lin, G.-Q. Highly diastereoselective addition of alkynylmagnesium chlorides to *N*-*tert*-butanesulfinyl aldimines: a practical and general access to chiral α -branched amines. *J. Org. Chem.* **2010**, *75*, 941–944.
- (62) Ye, L.; He, W.; Zhang, L. A flexible and stereoselective synthesis of azetidin-3-ones through gold-catalyzed intermolecular oxidation of alkynes. *Angew. Chem., Int. Ed.* **2011**, *50*, 3236–3239.
- (63) Murga, J.; Portolés, R.; Falomir, E.; Carda, M.; Marco, J. A. Stereoselective addition of organometallic reagents to a chiral acyclic nitronone derived from L-erythrulose. *Tetrahedron: Asymmetry* **2005**, *16*, 1807–1816.
- (64) Bonanni, M.; Marradi, M.; Cicchi, S.; Faggi, C.; Goti, A. Double addition of Grignard reagents to *N*-glycosyl nitrones: a new tool for the construction of enantiopure azaheterocycles. *Org. Lett.* **2005**, *7*, 319–322.

- (65) Katritzky, A. R.; Xie, L.; Zhang, G.; Griffith, M.; Watson, K.; Kiely, J. S. Synthesis of primary amines *via* nucleophilic addition of organometallic reagents to aldimines on solid support. *Tetrahedron Lett.* **1997**, *38*, 7011–7014.
- (66) Yamanaka, T.; Ohkubo, M.; Takahashi, F.; Kato, M. An efficient synthesis of the orally-active GpIIb/IIIa antagonist FR184764. *Tetrahedron Lett.* **2004**, *45*, 2843–2845.
- (67) Nakamura, S.; Nakashima, H.; Sugimoto, H.; Sano, H.; Hattori, M.; Shibata, N.; Toru, T. Enantioselective C–C bond formation to sulfonylimines through use of the 2-pyridinesulfonyl group as a novel stereocontroller. *Chem. Eur. J.* **2008**, *14*, 2145–2152.
- (68) Kano, T.; Kobayashi, R.; Maruoka, K. Synthesis of *N*-Boc-propargylic and allylic amines by reaction of organomagnesium reagents with *N*-Boc-aminals and their oxidation to *N*-Boc-ketimines. *Org. Lett.* **2016**, *18*, 276–279.
- (69) Murai, T.; Mutoh, Y.; Ohta, Y.; Murakami, M. Synthesis of tertiary propargylamines by sequential reactions of *in situ* generated thioiminium salts with organolithium and magnesium reagents. *J. Am. Chem. Soc.* **2004**, *126*, 5968–5969.
- (70) Ahn, J. H.; Joung, M. J.; Yoon, N. M.; Oniciu, D. C.; Katritzky, A. R. A new method of synthesis for propargylic amines and ethers *via* benzotriazole derivatives using sodium dialkynyldiethylaluminates. *J. Org. Chem.* **1999**, *64*, 488–492.
- (71) Turcaud, S.; Berhal, F.; Royer, J. Diastereoselective alkynylation of *N*-*p*-tolylsulfinylimines with aluminum acetylides. *J. Org. Chem.* **2007**, *72*, 7893–7897.
- (72) Benamer, M.; Turcaud, S.; Royer, J. Diastereoselective alkynylation of chiral phosphinoylimines: preparation of optically active propargylamines. *Tetrahedron Lett.* **2010**, *51*, 645–648.
- (73) Verrier, C.; Carret, S.; Poisson, J.-F. Highly diastereoselective addition of alkoxyethynyl aluminium reagents to *N*-*tert*-butylsulfinyl aldimines. *Org. Biomol. Chem.* **2014**, *12*, 1875–1878.

- (74) Alexakis, A.; Krause, N.; Woodward, S. *Copper-Catalyzed Asymmetric Synthesis*. Wiley-VCH, **2014**.
- (75) Guo, X.-X.; Gu, D.-W.; Wu, Z.; Zhang, W. Copper-catalyzed C–H functionalization reactions: efficient synthesis of heterocycles. *Chem. Rev.* **2015**, *115*, 1622–1651.
- (76) Allen, S. E.; Walvoord, R. R.; Padilla-Salinas, R.; Kozlowski, M. C. Aerobic Copper-Catalyzed Organic Reactions. *Chem. Rev.* **2013**, *113*, 6234–6458.
- (77) Evano, G.; Blanchard, N.; Toumi, M. Copper-mediated coupling reactions and their applications in natural products and designed biomolecules synthesis. *Chem. Rev.* **2008**, *108*, 3054–3131.
- (78) Chemler, S. R.; Fuller, P. H. Heterocycle synthesis by copper facilitated addition of heteroatoms to alkenes, alkynes and arenes. *Chem. Soc. Rev.* **2007**, *36*, 1153–1160.
- (79) Boettger, R. Ueber die Einwirkung des Leuchtgases auf verschiedene Salzsolutionen, insbesondere auf eine ammoniakalische Kupferchlorürlösung. *Justus Liebigs Ann. Chem.* **1859**, *109*, 351–362.
- (80) Li, C.-J.; Wei, C. Highly efficient Grignard-type imine additions *via* C-H activation in water and under solvent-free conditions. *Chem. Commun.* **2002**, 268–269.
- (81) Yoo, W.-J.; Zhao, L.; Li, C.-J. The A³-coupling (aldehyde-alkyne-amine) reaction: a versatile method for the preparation of propargyl amines. *Aldrichim. Acta* **2011**, *44*, 43-51.
- (82) Wei, C.; Li, C.-J. Enantioselective direct-addition of terminal alkynes to imines catalyzed by copper(I)pybox complex in water and in toluene. *J. Am. Chem. Soc.* **2002**, *124*, 5638–5639.
- (83) Wei, C.; Mague, J. T.; Li, C.-J. Cu(I)-catalyzed direct addition and asymmetric addition of terminal alkynes to imines. *Proc. Natl. Acad. Sci. United States Am.* **2004**, *101*, 5749–5754.

- (84) Zhang, J.; Wei, C.; Li, C.-J. Cu(I)Br mediated coupling of alkynes with *N*-acylimine and *N*-acyliminium ions in water. *Tetrahedron Lett.* **2002**, *43*, 5731–5733.
- (85) Bisai, A.; Singh, V. K. Enantioselective one-pot three-component synthesis of propargylamines. *Org. Lett.* **2006**, *8*, 2405–2408.
- (86) Weissberg, A.; Halak, B.; Portnoy, M. The first solid-phase synthesis of bis(oxazoliny)pyridine ligands. *J. Org. Chem.* **2005**, *70*, 4556–4559.
- (87) Ji, J.-X.; Wu, J.; Chan, A. S. C. Catalytic asymmetric alkynylation of α -imino ester: a versatile approach to optically active unnatural α -amino acid derivatives. *Proc. Natl. Acad. Sci. United States Am.* **2005**, *102*, 11196–11200.
- (88) Benaglia, M.; Negri, D.; Dell'Anna, G. Enantioselective addition of phenyl and alkyl acetylenes to imines catalyzed by chiral Cu(I) complexes. *Tetrahedron Lett.* **2004**, *45*, 8705–8708.
- (89) Colombo, F.; Benaglia, M.; Orlandi, S.; Uselli, F.; Celentano, G. Very mild, enantioselective synthesis of propargylamines catalyzed by copper(I)–bisimine complexes. *J. Org. Chem.* **2006**, *71*, 2064–2070.
- (90) Colombo, F.; Benaglia, M.; Orlandi, S.; Uselli, F. Asymmetric multicomponent copper catalyzed synthesis of chiral propargylamines. *J. Mol. Catal. A Chem.* **2006**, *260*, 128–134.
- (91) Koradin, C.; Polborn, K. and Knochel, P. Enantioselective synthesis of propargylamines by copper-catalyzed addition of alkynes to enamines. *Angew. Chem., Int. Ed.* **2002**, *41*, 2535–2538.
- (92) Gommermann, N.; Koradin, C.; Polborn, K.; Knochel, P. Enantioselective, copper(I)-catalyzed three-component reaction for the preparation of propargylamines. *Angew. Chem., Int. Ed.* **2003**, *42*, 5763–5766.

- (93) Gommermann, N.; Knochel, P. 2-Phenallyl as a versatile protecting group for the asymmetric one-pot three-component synthesis of propargylamines. *Chem. Commun.* **2005**, 4175–4177.
- (94) Gommermann, N.; Knochel, P. Preparation of functionalized primary chiral amines and amides *via* an enantioselective three-component synthesis of propargylamines. *Tetrahedron* **2005**, *61*, 11418–11426.
- (95) Knöpfel, T. F.; Aschwanden, P.; Ichikawa, T.; Watanabe, T.; Carreira, E. M. Readily available biaryl P,N ligands for asymmetric catalysis. *Angew. Chem., Int. Ed.* **2004**, *43*, 5971–5973.
- (96) Aschwanden, P.; Stephenson, C. R. J.; Carreira, E. M. Highly enantioselective access to primary propargylamines: 4-piperidinone as a convenient protecting group. *Org. Lett.* **2006**, *8*, 2437–2440.
- (97) Cardoso, F. S. P.; Abboud, K. A.; Aponick, A. Design, preparation, and implementation of an imidazole-based chiral biaryl P,N-ligand for asymmetric catalysis. *J. Am. Chem. Soc.* **2013**, *135*, 14548–14551.
- (98) Liu, B.; Liu, J.; Jia, X.; Huang, L.; Li, X.; Chan, A. S. C. The synthesis of chiral *N*-tosylatedaminoimine ligands and their application in enantioselective addition of phenylacetylene to imines. *Tetrahedron: Asymmetry* **2007**, *18*, 1124–1128.
- (99) Shao, Z.; Wang, J.; Ding, K.; Chan, A. S. C. Unprecedented effects of additives and ligand-to-metal ratio on the enantiofacial selection of copper-catalyzed alkynylation of α -imino ester with arylacetylenes. *Adv. Synth. Catal.* **2007**, *349*, 2375–2379.
- (100) Lu, Y.; Johnstone, T. C.; Arndtsen, B. A. Hydrogen-bonding asymmetric metal catalysis with α -amino acids: a simple and tunable approach to high enantioinduction. *J. Am. Chem. Soc.* **2009**, *131* (32), 11284–11285.

(101) Ohara, M.; Hara, Y.; Ohnuki, T.; Nakamura, S. Direct enantioselective three-component synthesis of optically active propargylamines in water. *Chem. Eur. J.* **2014**, *20*, 8848–8851.

(102) McDonagh, C.; O'Conghaile, P.; Klein Gebbink, R. J. M.; O'Leary, P. F. Electrostatic immobilisation of copper(I) and copper(II) bis(oxazolanyl)pyridine catalysts on silica: application to the synthesis of propargylamines *via* direct addition of terminal alkynes to imines. *Tetrahedron Lett.* **2007**, *48*, 4387–4390.

(103) Naeimi, H.; Moradian, M. Thioether-based copper(I) Schiff base complex as a catalyst for a direct and asymmetric A^3 -coupling reaction. *Tetrahedron: Asymmetry* **2014**, *25*, 429–434.

(104) Min, C.; Mittal, N.; Sun, D. X.; Seidel, D. Conjugate-base-stabilized brønsted acids as asymmetric catalysts: enantioselective Povarov reactions with secondary aromatic amines. *Angew. Chem., Int. Ed.* **2013**, *52*, 14084–14088.

(105) Mittal, N.; Sun, D. X.; Seidel, D. Conjugate-base-stabilized brønsted acids: catalytic enantioselective Pictet–Spengler reactions with unmodified tryptamine. *Org. Lett.* **2014**, *16*, 1012–1015.

(106) Zhao, C.; Seidel, D. Enantioselective A^3 reactions of secondary amines with a Cu(I)/acid–thiourea catalyst combination. *J. Am. Chem. Soc.* **2015**, *137*, 4650–4653.

(107) Gurubrahamam, R.; Periasamy, M. Copper(I) halide promoted diastereoselective synthesis of chiral propargylamines and chiral allenes using 2-dialkylaminomethylpyrrolidine, aldehydes, and 1-alkynes. *J. Org. Chem.* **2013**, *78*, 1463–1470.

(108) Guo, N.; Ji, J.-X. A novel and convenient copper-catalyzed three-component coupling of aldehydes, alkynes, and hydroxylamines leading to propargylamines. *Tetrahedron Lett.* **2012**, *53*, 4797–4801.

- (109) Carmona, R. C.; Wendler, E. P.; Sakae, G. H.; Comasseto, J. V.; Santos, A. A. D. A³-coupling reaction as a strategy towards the synthesis of alkaloids. *J. Braz. Chem. Soc.* **2015**, *26*, 117-123.
- (110) Ren, G.; Zhang, J.; Duan, Z.; Cui, M.; Wu, Y. A simple and economic synthesis of propargylamines by CuI-Catalyzed three-component coupling reaction with succinic acid as additive. *Aust. J. Chem.* **2009**, *62*, 75–81.
- (111) Chen, H.-B.; Zhao, Y.; Liao, Y. Aldehyde-alkyne-amine (A³) coupling catalyzed by a highly efficient dicopper complex. *RSC Adv.* **2015**, *5*, 37737–37741.
- (112) Lim, J.; Park, K.; Byeun, A.; Lee, S. Copper-catalyzed decarboxylative coupling reactions for the synthesis of propargyl amines. *Tetrahedron Lett.* **2014**, *55*, 4875–4878.
- (113) Youngman, M. A.; Dax, S. L. Mannich reactions of a resin-bound terminal alkyne. *Tetrahedron Lett.* **1997**, *38*, 6347–6350.
- (114) McNally, J. J.; Youngman, M. A.; Dax, S. L. Mannich reactions of resin-bound substrates: 2. A versatile three-component solid-phase organic synthesis methodology. *Tetrahedron Lett.* **1998**, *39*, 967–970.
- (115) Bieber, L. W.; da Silva, M. F. Mild and efficient synthesis of propargylamines by copper-catalyzed Mannich reaction. *Tetrahedron Lett.* **2004**, *45*, 8281–8283.
- (116) Okamura, T.; Asano, K.; Matsubara, S. Effects of a flexible alkyl chain on an imidazole ligand for copper-catalyzed Mannich reactions of terminal alkynes. *Synlett* **2010**, *2010*, 3053–3056.
- (117) Pang, T.; Yang, Q.; Gao, M.; Wang, M.; Wu, A. An efficient one-pot synthesis of macrocyclic compounds possessing propargylamine skeletons *via* mannich reaction. *Synlett* **2011**, *2011*, 3046–3052.

- (118) Yadav, J. S.; Subba Reddy, B. V.; Naveenkumar, V.; Srinivasa Rao, R.; Nagaiah, K. [bmim]PF₆/CuBr: A novel and recyclable catalytic system for the synthesis of propargyl amines. *New J. Chem.* **2004**, *28*, 335–337.
- (119) Park, S. B.; Alper, H. An efficient synthesis of propargylamines *via* C-H activation catalyzed by copper(I) in ionic liquids. *Chem. Commun.* **2005**, 1315-1317.
- (120) Zhang, Q.; Chen, J.-X.; Gao, W.-X.; Ding, J.-C.; Wu, H.-Y. Copper-catalyzed one-pot synthesis of propargylamines *via* C-H activation in PEG. *Appl. Organomet. Chem.* **2010**, *24*, 809–812.
- (121) Shi, L.; Tu, Y.-Q.; Wang, M.; Zhang, F.-M.; Fan, C.-A. Microwave-promoted three-component coupling of aldehyde, alkyne, and amine *via* C-H activation catalyzed by copper in water. *Org. Lett.* **2004**, *6*, 1001–1003.
- (122) Bariwal, J. B.; Ermolat'ev, D. S.; Van der Eycken, E. V., Efficient microwave-assisted synthesis of secondary alkylpropargylamines by using A³-coupling with primary aliphatic amines. *Chem. Eur. J.* **2010**, *16*, 3281-3284.
- (123) Trang, T. T. T.; Ermolat'ev, D. S.; Van der Eycken, E. V., Facile and diverse microwave-assisted synthesis of secondary propargylamines in water using CuCl/CuCl₂. *RSC Adv.* **2015**, *5*, 28921-28924.
- (124) Pereshivko, O. P.; Peshkov, V. A.; Van der Eycken, E. V. Unprecedented Cu(I)-catalyzed microwave-assisted three-component coupling of a ketone, an alkyne, and a primary amine. *Org. Lett.* **2010**, *12*, 2638–2641.
- (125) Du, W.-Q.; Zhang, J.-M.; Wu, R.; Liang, Q.; Zhu, S.-Z., One-pot preparation of fluorinated propargylamines under microwave irradiation and solvent-free conditions. *J. of Fluor. Chem.* **2008**, *129*, 695-700.

- (126) Chen, X.-L.; Zhang, J.-M.; Shang, W.-L.; Lu, B.-Q.; Jin, J.-A. Microwave promoted one-pot preparation of fluorinated propargylamines and their chemical transformation. *J. Fluor. Chem.* **2012**, *133*, 139–145.
- (127) Yamamoto, Y.; Hayashi, H. Multi-component coupling synthesis of polycyclic pyrrole derivatives *via* Ir- and Rh-catalyzed cycloisomerizations with microwave heating. *Tetrahedron* **2007**, *63*, 10149–10160.
- (128) Meyet, C. E.; Pierce, C. J.; Larsen, C. H. A single Cu(II) catalyst for the three-component coupling of diverse nitrogen sources with aldehydes and alkynes. *Org. Lett.* **2012**, *14*, 964–967.
- (129) Pierce, C. J.; Larsen, C. H. Copper(II) catalysis provides cyclohexanone-derived propargylamines free of solvent or excess starting materials: sole by-product is water. *Green Chem.* **2012**, *14*, 2672–2676.
- (130) Palchak, Z. L.; Lussier, D. J.; Pierce, C. J.; Larsen, C. H. Synthesis of tetrasubstituted propargylamines from cyclohexanone by solvent-free copper(II) catalysis. *Green Chem.* **2015**, *17*, 1802–1810.
- (131) Liu, G.; Cogan, D. A.; Owens, T. D.; Tang, T. P.; Ellman, J. A. Synthesis of enantiomerically pure *N*-*tert*-butanesulfinyl imines (*tert*-butanesulfinimines) by the direct condensation of *tert*-butanesulfinamide with aldehydes and ketones. *J. Org. Chem.* **1999**, *64*, 1278–1284.
- (132) Pierce, C. J.; Nguyen, M.; Larsen, C. H. Copper/titanium catalysis forms fully substituted carbon centers from the direct coupling of acyclic ketones, amines, and alkynes. *Angew. Chem., Int. Ed.* **2012**, *51*, 12289–12292.
- (133) Cai, Y.; Tang, X.; Ma, S. Identifying a highly active copper catalyst for KA² reaction of aromatic ketones. *Chem. Eur. J.* **2016**, *22*, 2266–2269.

(134) Tajbaksh, M.; Farhang, M.; Mardani, H. R.; Hosseinzadeh, R.; Sarrafi, Y. Cu (II) salen complex catalyzed synthesis of propargylamines by a three-component coupling reaction. *Chin. J. Catal.* **2013**, *34*, 2217–2222.

(135) Li, Z.; Jiang, Z.; Su, W. Fast, solvent-free, highly enantioselective three-component coupling of aldehydes, alkynes, and amines catalysed by the copper(II)pybox complex under high-vibration ball-milling. *Green Chem.* **2015**, *17*, 2330–2334.

(136) Venu Madhav, J.; Suresh Kuarm, B.; Someshwar, P.; Rajitha, B.; Thirupathi Reddy, Y.; Crooks, P. A. CuPy₂Cl₂: a novel and efficient catalyst for synthesis of propargylamines under the conventional method and microwave irradiation. *Synth. Commun.* **2008**, *38*, 3215–3223.

(137) Li, Z.; Li, C.-J. CuBr-catalyzed efficient alkynylation of sp³ C–H bonds adjacent to a nitrogen atom. *J. Am. Chem. Soc.* **2004**, *126*, 11810–11811.

(138) Niu, M.; Yin, Z.; Fu, H.; Jiang, Y.; Zhao, Y. Copper-catalyzed coupling of tertiary aliphatic amines with terminal alkynes to propargylamines *via* C–H Activation. *J. Org. Chem.* **2008**, *73*, 3961–3963.

(139) Xu, Z.; Yu, X.; Feng, X.; Bao, M. Propargylamine synthesis by copper-catalyzed oxidative coupling of alkynes and tertiary amine *N*-oxides. *J. Org. Chem.* **2011**, *76*, 6901–6905.

(140) Imada, Y.; Yuasa, M.; Nakamura, I.; Murahashi, S.-I. Copper(I)-catalyzed amination of propargyl esters. Selective synthesis of propargylamines, 1-alken-3-ylamines, and (*Z*)-allylamines. *J. Org. Chem.* **1994**, *59*, 2282–2284.

(141) Detz, R. J.; Delville, M. M. E.; Hiemstra, H.; van Maarseveen, J. H. Enantioselective copper-catalyzed propargylic amination. *Angew. Chem., Int. Ed.* **2008**, *47*, 3777–3780.

(142) Hattori, G.; Matsuzawa, H.; Miyake, Y.; Nishibayashi, Y. Copper-catalyzed asymmetric propargylic substitution reactions of propargylic acetates with amines. *Angew. Chem., Int. Ed.* **2008**, *47*, 3781–3783.

(143) Hattori, G.; Sakata, K.; Matsuzawa, H.; Tanabe, Y.; Miyake, Y.; Nishibayashi, Y. Copper-catalyzed enantioselective propargylic amination of propargylic esters with amines: copper–allenylidene complexes as key intermediates. *J. Am. Chem. Soc.* **2010**, *132*, 10592–10608.

(144) Detz, R. J.; Abiri, Z.; le Griel, R.; Hiemstra, H.; van Maarseveen, J. H. Enantioselective copper-catalysed propargylic substitution: synthetic scope study and application in formal total syntheses of (+)-Anisomycin and (–)-Cytosazone. *Chem. Eur. J.* **2011**, *17*, 5921–5930.

(145) Yoshida, A.; Hattori, G.; Miyake, Y.; Nishibayashi, Y. Copper-catalyzed enantioselective propargylic amination of nonaromatic propargylic esters with amines. *Org. Lett.* **2011**, *13*, 2460–2463.

(146) Zhang, C.; Wang, Y.-H.; Hu, X.-H.; Zheng, Z.; Xu, J.; Hu, X.-P. Chiral tridentate P,N,N ligands for highly enantioselective copper-catalyzed propargylic amination with both primary and secondary amines as nucleophiles. *Adv. Synth. Catal.* **2012**, *354*, 2854–2858.

(147) Mino, T.; Taguchi, H.; Hashimoto, M.; Sakamoto, M. Copper-catalyzed asymmetric propargylic amination of propargylic acetates with amines using BICMAP. *Tetrahedron: Asymmetry* **2013**, *24*, 1520–1523.

(148) Zou, Y.; Zhu, F.-L.; Duan, Z.-C.; Wang, Y.-H.; Zhang, D.-Y.; Cao, Z.; Zheng, Z.; Hu, X.-P. Enantioselective Cu-catalyzed decarboxylative propargylic amination of propargyl carbamates. *Tetrahedron Lett.* **2014**, *55*, 2033–2036.

- (149) Hattori, G.; Yoshida, A.; Miyake, Y.; Nishibayashi, Y. Enantioselective ring-opening reactions of racemic ethynyl epoxides *via* copper–allenylidene intermediates: efficient approach to chiral β -amino alcohols. *J. Org. Chem.* **2009**, *74*, 7603–7607.
- (150) Zhou, L.; Jiang, H.; Li, C.-J. Efficient synthesis of γ,δ -Alkynyl- β -Amino acid derivatives by a new copper-catalyzed amine-alkyne-alkyne addition reaction. *Adv. Synth. Catal.* **2008**, *350*, 2226–2230.
- (151) Zhou, L.; Bohle, D. S.; Jiang, H.-F.; Li, C.-J. Synthesis of Propargylamines by a Copper-catalyzed tandem *anti*-Markovnikov hydroamination and alkyne addition. *Synlett* **2009**, 937–940.
- (152) Zhu, Y.; Zhao, H.; Wei, Y. Efficient one-pot synthesis of propargylamines from mannich bases through a retro-mannich-type fragmentation. *Synthesis* **2013**, *45*, 952–958.
- (153) Mitamura, T.; Nomoto, A.; Sonoda, M.; Ogawa, A. Copper(0)-induced aminocyclopropanation of olefins *via* deselenation of *N,N*-disubstituted aromatic selenoamides. *Tetrahedron* **2008**, *64*, 9983–9988.
- (154) Mitamura, T.; Ogawa, A. Copper(0)-induced deselenative insertion of *N,N*-disubstituted selenoamides into acetylenic C–H bond leading to propargylamines. *Org. Lett.* **2009**, *11*, 2045–2048.
- (155) Sreedhar, B.; Surendra Reddy, P.; Vamsi Krishna, C. S.; Vijaya Babu, P. An efficient synthesis of propargylamines using a silica gel anchored copper chloride catalyst in an aqueous medium. *Tetrahedron Lett.* **2007**, *48*, 7882–7886.
- (156) Fodor, A.; Kiss, A.; Debreczeni, N.; Hell, Z.; Gresits, I. A simple method for the preparation of propargylamines using molecular sieve modified with copper(II). *Org. Biomol. Chem.* **2010**, *8*, 4575–4581.

(157) Kodicherla, B.; Perumgani, P. C.; Mandapati, M. R. Polymer-anchored copper(II) complex: an efficient reusable catalyst for the synthesis of propargylamines. *Appl. Organomet. Chem.* **2014**, *28*, 756–759.

(158) Naeimi, H.; Moradian, M. Copper(I)-N₂S₂-Salen type complex covalently anchored onto MCM-41 silica: an efficient and reusable catalyst for the A³-coupling reaction toward propargylamines. *Appl. Organomet. Chem.* **2013**, *27*, 300–306.

(159) Luz, I.; Llabrés i Xamena, F. X.; Corma, A. Bridging homogeneous and heterogeneous catalysis with MOFs: Cu-MOFs as solid catalysts for three-component coupling and cyclization reactions for the synthesis of propargylamines, indoles and imidazopyridines. *J. Catal.* **2012**, *285*, 285-291.

(160) Li, P.; Regati, S.; Huang, H.-C.; Arman, H. D.; Chen, B.-L.; Zhao, J. C. G. A sulfonate-based Cu(I) metal-organic framework as a highly efficient and reusable catalyst for the synthesis of propargylamines under solvent-free conditions. *Chinese Chem. Lett.* **2015**, *26*, 6-10.

(161) Dang, G. H.; Nguyen, D. T.; Le, D. T.; Truong, T.; Phan, N. T. S. Propargylamine synthesis *via* direct oxidative CC coupling reaction between *N,N*-dimethylanilines and terminal alkynes under metal–organic framework catalysis. *J. Mol. Catal. A Chem.* **2014**, *395*, 300–306.

(162) Dang, G. H.; Dang, T. T.; Le, D. T.; Truong, T.; Phan, N. T. S. Propargylamine synthesis *via* sequential methylation and C–H functionalization of *N*-methylanilines and terminal alkynes under metal–organic framework Cu₂(BDC)₂(DABCO) catalysis. *J. Catal.* **2014**, *319*, 258–264.

(163) Xiong, X.; Chen, H.; Zhu, R. Highly efficient and scale-up synthesis of propargylamines catalyzed by graphene oxide-supported CuCl₂ catalyst under microwave condition. *Catal. Commun.* **2014**, *54*, 94–99.

- (164) Bosica, G.; Gabarretta, J. Unprecedented one-pot multicomponent synthesis of propargylamines using amberlyst A-21 supported cui under solvent-free conditions. *RSC Adv.* **2015**, *5*, 46074–46087.
- (165) Lakshmi Kantam, M.; Laha, S.; Yadav, J.; Bhargava, S. An efficient synthesis of propargylamines *via* three-component coupling of aldehydes, amines and alkynes catalyzed by nanocrystalline copper(II) oxide. *Tetrahedron Lett.* **2008**, *49*, 3083–3086.
- (166) Kantam, M. L.; Yadav, J.; Laha, S.; Jha, S. Synthesis of propargylamines by three-component coupling of aldehydes, amines and alkynes catalyzed by magnetically separable copper ferrite nanoparticles. *Synlett* **2009**, *2009*, 1791–1794.
- (167) Abdollahi-Alibeik, M.; Moaddeli, A., Copper modified spherical MCM-41 nano particles: an efficient catalyst for the three-component coupling of aldehydes, amines and alkynes in solvent-free conditions. *RSC Adv.* **2014**, *4*, 39759-39766.
- (168) Katkar, S. V; Jayaram, R. V. Cu-Ni bimetallic reusable catalyst for synthesis of propargylamines *via* multicomponent coupling reaction under solvent-free conditions. *RSC Adv.* **2014**, *4*, 47958–47964.
- (169) Mirabedini, M.; Motamedi, E.; Kassae, M. Z. Magnetic CuO nanoparticles supported on graphene oxide as an efficient catalyst for A³-coupling synthesis of propargylamines. *Chinese Chem. Lett.* **2015**, *26*, 1085–1090.
- (170) Nasrollahzadeh, M.; Mohammad Sajadi, S.; Rostami-Vartooni, A. Green synthesis of CuO nanoparticles by aqueous extract of anthemis nobilis flowers and their catalytic activity for the A³ coupling reaction. *J. Colloid Interface Sci.* **2015**, *459*, 183–188.
- (171) Sasikala, R.; Rani, S. K.; Easwaramoorthy, D.; Karthikeyan, K. Lanthanum loaded CuO nanoparticles: synthesis and characterization of a recyclable catalyst for the synthesis of 1,4-disubstituted 1,2,3-triazoles and propargylamines. *RSC Adv.* **2015**, *5*, 56507-56517.

(172) Guo, H.; Liu, X.; Xie, Q.; Wang, L.; Peng, D.-L.; Branco, P. S.; Gawande, M. B. Disproportionation route to monodispersed copper nanoparticles for the catalytic synthesis of propargylamines. *RSC Adv.* **2013**, *3*, 19812-19815.

(173) Srinivas, M.; Srinivasu, P.; Bhargava, S. K.; Kantam, M. L. Direct synthesis of two-dimensional mesoporous copper silicate as an efficient catalyst for synthesis of propargylamines. *Catal. Today* **2013**, *208*, 66–71.

(174) Srivastava, R.; Anu Prathap, M. U.; Kore, R. Morphologically controlled synthesis of copper oxides and their catalytic applications in the synthesis of propargylamine and oxidative degradation of methylene blue. *Colloids Surfaces A Physicochem. Eng. Asp.* **2011**, *392*, 271–282.

(175) Nguyen, A. T.; Pham, L. T.; Phan, N. T. S.; Truong, T. Efficient and robust superparamagnetic copper ferrite nanoparticle-catalyzed sequential methylation and C-H activation: aldehyde-free propargylamine synthesis. *Catal. Sci. Technol.* **2014**, *4*, 4281–4288.

(176) Tajbakhsh, M.; Farhang, M.; Baghbanian, S. M.; Hosseinzadeh, R.; Tajbakhsh, M. Nano magnetite supported metal ions as robust, efficient and recyclable catalysts for green synthesis of propargylamines and 1,4-disubstituted 1,2,3-triazoles in water. *New J. Chem.* **2015**, *39*, 1827–1839.

(177) Frantz, D. E.; Fässler, R.; Carreira, E. M. Catalytic *in situ* generation of Zn(II)-alkynilides under mild conditions: a novel CN addition process utilizing terminal acetylenes. *J. Am. Chem. Soc.* **1999**, *121*, 11245–11246.

(178) Fässler, R.; Frantz, D. E.; Oetiker, J.; Carreira, E. M. First synthesis of optically pure propargylic *N*-hydroxylamines by direct, highly diastereoselective addition of terminal alkynes to nitrones. *Angew. Chem., Int. Ed.* **2002**, *41*, 3054–3056.

- (179) Topić, D.; Aschwanden, P.; Fässler, R.; Carreira, E. M. ZnCl₂-Mediated stereoselective addition of terminal alkynes to D-(+)-mannofuranosyl nitrones. *Org. Lett.* **2005**, *7*, 5329–5330.
- (180) Downey, C. W.; Maxwell, E. N.; Confair, D. N. Silyl triflate-accelerated additions of catalytically generated zinc acetylides to *N*-phenyl nitrones. *Tetrahedron Lett.* **2014**, *55*, 4959–4961.
- (181) Pinet, S.; Pandya, S. U.; Chavant, P. Y.; Ayling, A.; Vallee, Y. Dialkylzinc-assisted alkynylation of nitrones. *Org. Lett.* **2002**, *4*, 1463–1466.
- (182) Jiang, B.; Si, Y.-G. Lewis acid promoted alkynylation of imines with terminal alkynes: simple, mild and efficient preparation of propargylic amines. *Tetrahedron Lett.* **2003**, *44*, 6767–6768.
- (183) Fischer, C.; Carreira, E. M. Zn-Alkynylide additions to acyl iminiums. *Org. Lett.* **2004**, *6*, 1497–1499.
- (184) Lee, K. Y.; Lee, C. G.; Na, J. E.; Kim, J. N. Alkynylation of *N*-tosylimines with aryl acetylenes promoted by ZnBr₂ and *N,N*-diisopropylethylamine in acetonitrile. *Tetrahedron Lett.* **2005**, *46*, 69–74.
- (185) Lee, K. Y.; Lee, M. J.; Kim, J. N. Efficient introduction of aryl acetylenes to quinolinium and pyridinium salts: synthesis of 1-acyl-1,2-dihydroquinolines and 1-acyl-1,2-dihydropyridines. *Bull. Korean Chem. Soc.* **2005**, *26*, 665–667.
- (186) Zani, L.; Alesi, S.; Cozzi, P. G.; Bolm, C. Dimethylzinc-mediated alkynylation of imines. *J. Org. Chem.* **2006**, *71*, 1558–1562.
- (187) Ramu, E.; Varala, R.; Sreelatha, N.; Adapa, S. R. Zn(OAc)₂·2H₂O: A versatile catalyst for the one-pot synthesis of propargylamines. *Tetrahedron Lett.* **2007**, *48*, 7184–7190.

- (188) Kantam, M. L.; Balasubrahmanyam, V.; Kumar, K. B. S.; Venkanna, G. T. Efficient one-pot synthesis of propargylamines using zinc dust. *Tetrahedron Lett.* **2007**, *48*, 7332–7334.
- (189) Wei, W.; Kobayashi, M.; Ukaji, Y.; Inomata, K. Asymmetric addition of alkynylzinc reagents to nitrones utilizing tartaric acid ester as a chiral auxiliary. *Chem. Lett.* **2006**, *35*, 176–177.
- (190) Huang, G.; Yin, Z.; Zhang, X. Construction of optically active quaternary propargyl amines by highly enantioselective zinc/BINOL-catalyzed alkynylation of ketoimines. *Chem. Eur. J.* **2013**, *19*, 11992–11998.
- (191) Periasamy, M.; Reddy, P. O.; Satyanarayana, I.; Mohan, L.; Edukondalu, A. Diastereoselective synthesis of tetrasubstituted propargylamines *via* hydroamination and metalation of 1-alkynes and their enantioselective conversion to trisubstituted chiral allenes. *J. Org. Chem.* **2016**, *81*, 987–999.
- (192) Sugiishi, T.; Nakamura, H. Zinc(II)-catalyzed redox cross-dehydrogenative coupling of propargylic amines and terminal alkynes for synthesis of n-tethered 1,6-enynes. *J. Am. Chem. Soc.* **2012**, *134*, 2504–2507.
- (193) Wei, C.; Li, C.-J. A highly efficient three-component coupling of aldehyde, alkyne, and amines *via* C–H activation catalyzed by gold in water. *J. Am. Chem. Soc.* **2003**, *125*, 9584–9585.
- (194) Srinivas, V.; Koketsu, M. Synthesis of indole-2-, 3-, or 5-substituted propargylamines *via* gold(III)-catalyzed three component reaction of aldehyde, alkyne, and amine in aqueous medium. *Tetrahedron* **2013**, *69*, 8025–8033.
- (195) Lo, V. K.-Y.; Liu, Y.; Wong, M.-K.; Che, C.-M. Gold(III) salen complex-catalyzed synthesis of propargylamines *via* a three-component coupling reaction. *Org. Lett.* **2006**, *8*, 1529–1532.

- (196) Lo, V. K.-Y.; Kung, K. K.-Y.; Wong, M.-K.; Che, C.-M. Gold(III) (C^N) complex-catalyzed synthesis of propargylamines *via* a three-component coupling reaction of aldehydes, amines and alkynes. *J. Organomet. Chem.* **2009**, *694*, 583–591.
- (197) Ko, H.-M.; Kung, K. K.-Y.; Cui, J.-F.; Wong, M.-K. Bis-cyclometallated gold(III) complexes as efficient catalysts for synthesis of propargylamines and alkylated indoles. *Chem. Commun.* **2013**, *49*, 8869–8871.
- (198) Kantam, M. L.; Prakash, B. V.; Reddy, C. R. V.; Sreedhar, B. Layered double hydroxide-supported gold catalyst for three-component aldehyde-amine-alkyne coupling. *Synlett* **2005**, *2005*, 2329–2332.
- (199) Kidwai, M.; Bansal, V.; Kumar, A.; Mozumdar, S. The first Au-nanoparticles catalyzed green synthesis of propargylamines *via* a three-component coupling reaction of aldehyde, alkyne and amine. *Green Chem.* **2007**, *9*, 742–745.
- (200) Layek, K.; Chakravarti, R.; Lakshmi Kantam, M.; Maheswaran, H.; Vinu, A. Nanocrystalline magnesium oxide stabilized gold nanoparticles: an advanced nanotechnology based recyclable heterogeneous catalyst platform for the one-pot synthesis of propargylamines. *Green Chem.* **2011**, *13*, 2878–2887.
- (201) Gonzalez-Bejar, M.; Peters, K.; Hallett-Tapley, G. L.; Grenier, M.; Scaiano, J. C. Rapid one-pot propargylamine synthesis by plasmon mediated catalysis with gold nanoparticles on ZnO under ambient conditions. *Chem. Commun.* **2013**, *49*, 1732–1734.
- (202) Lili, L.; Xin, Z.; Jinsen, G.; Chunming, X. Engineering metal-organic frameworks immobilize gold catalysts for highly efficient one-pot synthesis of propargylamines. *Green Chem.* **2012**, *14*, 1710–1720.
- (203) Abahmane, L.; Köhler, J. M.; Groß, G. A. Gold-nanoparticle-catalyzed synthesis of propargylamines: the traditional A³-multicomponent reaction performed as a two-step flow process. *Chem. Eur. J.* **2011**, *17*, 3005–3010.

- (204) Moghaddam, F. M.; Ayati, S. E.; Hosseini, S. H.; Pourjavadi, A. Gold immobilized onto poly(ionic liquid) functionalized magnetic nanoparticles: a robust magnetically recoverable catalyst for the synthesis of propargylamine in water. *RSC Adv.* **2015**, *5*, 34502–34510.
- (205) Bhargava, A.; Jain, N.; Gangopadhyay, S.; Panwar, J. Development of gold nanoparticle-fungal hybrid based heterogeneous interface for catalytic applications. *Process Biochem.* **2015**, *50*, 1293–1300.
- (206) Corma, A.; Navas, J.; Sabater, M. J. Coupling of two multistep catalytic cycles for the one-pot synthesis of propargylamines from alcohols and primary amines on a nanoparticulated gold catalyst. *Chem. Eur. J.* **2012**, *18*, 14150–14156.
- (207) Feiz, A.; Bazgir, A. Gold nanoparticles supported on mercaptoethanol directly bonded to MCM-41: an efficient catalyst for the synthesis of propargylamines. *Catal. Commun.* **2016**, *73*, 88–92.
- (208) Borah, B. J.; Borah, S. J.; Saikia, K.; Dutta, D. K. Efficient one-pot synthesis of propargylamines catalysed by gold nanocrystals stabilized on montmorillonite. *Catal. Sci. Technol.* **2014**, *4*, 4001–4009.
- (209) Aguilar, D.; Contel, M.; Urriolabeitia, E. P. Mechanistic insights into the one-pot synthesis of propargylamines from terminal alkynes and amines in chlorinated solvents catalyzed by gold compounds and nanoparticles. *Chem. Eur. J.* **2010**, *16*, 9287–9296.
- (210) Wei, C.; Li, Z.; Li, C.-J. The first silver-catalyzed three-component coupling of aldehyde, alkyne, and amine. *Org. Lett.* **2003**, *5*, 4473–4475.
- (211) Ji, J.-X.; Au-Yeung, T. T.-L.; Wu, J.; Yip, C. W.; Chan, A. S. C. Efficient synthesis of β,γ -alkynyl α -amino acid derivatives by Ag(I)-catalyzed alkynylation of α -imino esters. *Adv. Synth. Catal.* **2004**, *346*, 42–44.

(212) Josephsohn, N. S.; Snapper, M. L.; Hoveyda, A. H. Ag-catalyzed asymmetric Mannich reactions of enol ethers with aryl, alkyl, alkenyl, and alkynyl imines. *J. Am. Chem. Soc.* **2004**, *126*, 3734–3735.

(213) Josephsohn, N. S.; Carswell, E. L.; Snapper, M. L.; Hoveyda, A. H. Practical and highly enantioselective synthesis of β -alkynyl- β -amino esters through Ag-catalyzed asymmetric Mannich reactions of silylketene acetals and alkynyl imines. *Org. Lett.* **2005**, *7*, 2711–2713.

(214) Rueping, M.; Antonchick, A. P.; Brinkmann, C. Dual catalysis: a combined enantioselective Brønsted acid and metal-catalyzed reaction—metal catalysis with chiral counterions. *Angew. Chem., Int. Ed.* **2007**, *46*, 6903–6906.

(215) Ren, Y.-Y.; Wang, Y.-Q.; Liu, S. Asymmetric alkynylation of seven-membered cyclic imines by combining chiral phosphoric acids and Ag(I) catalysts: synthesis of 11-substituted-10,11-dihydrodibenzo[b,f][1,4]oxazepine derivatives. *J. Org. Chem.* **2014**, *79*, 11759–11767.

(216) Chen, X.; Chen, T.; Zhou, Y.; Au, C.-T.; Han, L.-B.; Yin, S.-F. Efficient synthesis of propargylamines from terminal alkynes, dichloromethane and tertiary amines over silver catalysts. *Org. Biomol. Chem.* **2014**, *12*, 247–250.

(217) He, Y.; Lv, M.; Cai, C. A Simple procedure for polymer-supported N-heterocyclic carbene silver complex *via* click chemistry: an efficient and recyclable catalyst for the one-pot synthesis of propargylamines. *Dalt. Trans.* **2012**, *41*, 12428–12433.

(218) Maggi, R.; Bello, A.; Oro, C.; Sartori, G.; Soldi, L. AgY Zeolite as catalyst for the effective three-component synthesis of propargylamines. *Tetrahedron* **2008**, *64*, 1435–1439.

(219) Zhou, X.; Lu, Y.; Zhai, L.-L.; Zhao, Y.; Liu, Q.; Sun, W.-Y. Propargylamines formed from three-component coupling reactions catalyzed by silver oxide nanoparticles. *RSC Adv.* **2013**, *3*, 1732–1734.

- (220) Jeganathan, M.; Dhakshinamoorthy, A.; Pitchumani, K. One-pot synthesis of propargylamines using Ag(I)-exchanged K10 montmorillonite clay as reusable catalyst in water. *ACS Sustain. Chem. Eng.* **2014**, *2*, 781-787.
- (221) Movahedi, F.; Masrouri, H.; Kassaei, M. Z. Immobilized silver on surface-modified ZnO nanoparticles: as an efficient catalyst for synthesis of propargylamines in water. *J. Mol. Catal. A Chem.* **2014**, *395*, 52-57.
- (222) Fischer, C.; Carreira, E. M. Direct addition of TMS-acetylene to aldimines catalyzed by a simple, commercially available Ir(I) complex. *Org. Lett.* **2001**, *3*, 4319-4321.
- (223) Fischer, C.; Carreira, E. M. MgI₂ as an additive in Ir(I)-catalyzed addition of silylacetylenes to imines: expeditious synthesis of propargylic amines. *Synthesis*. **2004**, *2004*, 1497-1503.
- (224) Sakaguchi, S.; Mizuta, T.; Furuwan, M.; Kubo, T.; Ishii, Y. Iridium-catalyzed coupling of simple primary or secondary amines, aldehydes and trimethylsilylacetylene: preparation of propargylic amines. *Chem. Commun.* **2004**, *14*, 1638-1639.
- (225) Rubio-Pérez, L.; Iglesias, M.; Munárriz, J.; Polo, V.; Sanz Miguel, P. J.; Pérez-Torrente, J. J.; Oro, L. A. A bimetallic iridium(II) catalyst: [$\{\text{Ir}(\text{IDipp})(\text{H})\}_2[\text{BF}_4]_2$ (IDipp = 1,3-bis(2,6-diisopropylphenylimidazol-2-ylidene)). *Chem. Commun.* **2015**, *51*, 9860-9863.
- (226) Rubio-Pérez, L.; Iglesias, M.; Munárriz, J.; Polo, V.; Pérez-Torrente, J. J.; Oro, L. A. Efficient rhodium-catalyzed multicomponent reaction for the synthesis of novel propargylamines. *Chem. Eur. J.* **2015**, *21*, 17701-17707.
- (227) Sakai, N.; Kanada, R.; Hirasawa, M.; Konakahara, T. Facile and convenient synthesis of functionalized propargylic alcohols and amines: an InBr₃-Et₃N reagent system promotes the alkynylation of aldehydes and N,O- or N,S-acetals. *Tetrahedron* **2005**, *61*, 9298-9304.

(228) Zhang, Y.; Li, P.; Wang, M.; Wang, L. Indium-catalyzed highly efficient three-component coupling of aldehyde, alkyne, and amine *via* C–H bond activation. *J. Org. Chem.* **2009**, *74*, 4364–4367.

(229) Yadav, J. S.; Subba Reddy, B. V; Hara Gopal, A. V; Patil, K. S. InBr₃-catalyzed three-component reaction: a facile synthesis of propargyl amines. *Tetrahedron Lett.* **2009**, *50*, 3493–3496.

(230) Ji, D.-M.; Xu, M.-H. InBr₃-catalyzed direct alkynylation of nitrones with terminal alkynes: an efficient synthesis of *N*-hydroxy-propargyl amines. *Tetrahedron Lett.* **2009**, *50*, 2952–2955.

(231) Da Silva, T. L.; Rambo, R. S.; Rampon, D. da S.; Radatz, C. S.; Benvenuti, E. V.; Russowsky, D.; Schneider, P. H. Covalently immobilized indium(III) composite (In/SiO₂) as highly efficient reusable catalyst for A³-coupling of aldehydes, alkynes and amines under solvent-free conditions. *J. Mol. Catal. A Chem.* **2015**, *399*, 71–78.

(232) Rahman, M.; Bagdi, A. K.; Majee, A.; Hajra, A. Nano indium oxide catalyzed efficient synthesis of propargylamines *via* C–H and C–Cl bond activations. *Tetrahedron Lett.* **2011**, *52*, 4437–4439.

(233) Traverse, J. F.; Hoveyda, A. H.; Snapper, M. L. Enantioselective synthesis of propargylamines through Zr-catalyzed addition of mixed alkynylzinc reagents to arylimines. *Org. Lett.* **2003**, *5*, 3273–3275.

(234) Akullian, L. C.; Snapper, M. L.; Hoveyda, A. H. Three-component enantioselective synthesis of propargylamines through Zr-catalyzed additions of alkyl zinc reagents to alkynylimines. *Angew. Chem., Int. Ed. Engl.* **2003**, *42*, 4244–4247.

(235) Teimouri, A.; Chermahini, A. N.; Narimani, M. A simple and efficient one-pot three-component synthesis of propargylamines using bismuth(III) chloride. *Bull. Korean Chem. Soc.* **2012**, *33*, 1556–1560.

(236) Chen, W.-W.; Bi, H.-P.; Li, C.-J. The first cobalt-catalyzed transformation of alkynyl C-H bond: aldehyde-alkyne-amine (A^3) coupling. *Synlett* **2010**, 2010, 475–479.

(237) Tang, Y.; Xiao, T.; Zhou, L. Cobalt-catalyzed alkyne–dihalomethane–amine coupling: an efficient route for propargylamines. *Tetrahedron Lett.* **2012**, 53, 6199–6201.

(238) Gao, J.; Song, Q.-W.; He, L.-N.; Yang, Z.-Z.; Dou, X.-Y. Efficient iron(III)-catalyzed three-component coupling reaction of alkynes, CH_2Cl_2 and amines to propargylamines. *Chem. Commun.* **2012**, 48, 2024–2026.

(239) Lanke, S. R.; Bhanage, B. M. Nickel-catalyzed three-component coupling reaction of terminal alkynes, dihalomethane and amines to propargylamines. *Appl. Organomet. Chem.* **2013**, 27, 729–733.

(240) Kaur, S.; Kumar, M.; Bhalla, V. Aggregates of perylene bisimide stabilized superparamagnetic Fe_3O_4 nanoparticles: an efficient catalyst for the preparation of propargylamines and quinolines *via* C-H activation. *Chem. Commun.* **2015**, 51, 16327–16330.

(241) Bhatte, K. D.; Sawant, D. N.; Deshmukh, K. M.; Bhanage, B. M. Nanosize Co_3O_4 as a novel, robust, efficient and recyclable catalyst for A^3 -coupling reaction of propargylamines. *Catal. Commun.* **2011**, 16, 114–119.

(242) Sharma, R. K.; Sharma, S.; Gaba, G. Silica nanospheres supported diazafluorene iron complex: an efficient and versatile nanocatalyst for the synthesis of propargylamines from terminal alkynes, dihalomethane and amines. *RSC Adv.* **2014**, 4, 49198–49211.

(243) Afraj, S. N.; Chen, C.; Lee, G.-H. Manganese(II) chloride catalyzed highly efficient one-pot synthesis of propargylamines and fused triazoles *via* three-component coupling reaction under solvent-free condition. *RSC Adv.* **2014**, 4, 26301–26308.

(244) Afraj, S. N.; Chen, C. Tin(II) chloride catalyzed multicomponent synthesis of propargylamines and intramolecular [3+2] cycloaddition. *Asian J. Org. Chem.* **2016**, *5*, 257–263.

(245) Wu, T. R.; Chong, J. M. Asymmetric synthesis of propargylamides via 3,3'-disubstituted binaphthol-modified alkynylboronates. *Org. Lett.* **2006**, *8*, 15–18.

(246) Gonzalez, A. Z.; Canales, E.; Soderquist, J. A. *N*-Propargylamides via the asymmetric Michael addition of β -alkynyl-10-TMS-9-borabicyclo[3.3.2]decanes to *N*-acylimines. *Org. Lett.* **2006**, *8*, 3331–3334.

(247) Feng, H.; Jia, H.; Sun, Z. Mild and Catalyst-free Petasis/decarboxylative domino reaction: chemoselective synthesis of *N*-benzyl propargylamines. *J. Org. Chem.* **2014**, *79*, 11812–11818.

(248) Wang, J.; Shen, Q.; Zhang, J.; Song, G. Metal-free multicomponent coupling reaction of aliphatic amines, formaldehyde, organoboronic acids, and propiolic acids for the synthesis of diverse propargylamines. *Tetrahedron Lett.* **2015**, *56*, 903–906.

(249) Wang, J.; Shen, Q.; Li, P.; Peng, Y.; Song, G. Synthesis of tertiary propargylamines via a rationally designed multicomponent reaction of primary amines, formaldehyde, arylboronic acids and alkynes. *Org. Biomol. Chem.* **2014**, *12*, 5597–5600.

(250) Jiang, Y.-B.; Zhang, W.-S.; Cheng, H.-L.; Liu, Y.-Q.; Yang, R. One-pot synthesis of *N*-aryl propargylamine from aromatic boronic acid, aqueous ammonia, and propargyl bromide under microwave-assisted conditions. *Chinese Chem. Lett.* **2014**, *25*, 779–782.

(251) Rawat, V. S.; Bathini, T.; Govardan, S.; Sreedhar, B. Catalyst-free activation of methylene chloride and alkynes by amines in a three-component coupling reaction to synthesize propargylamines. *Org. Biomol. Chem.* **2014**, *12*, 6725–6729.

(252) Park, K.; Heo, Y.; Lee, S. Metal-free decarboxylative three-component coupling reaction for the synthesis of propargylamines. *Org. Lett.* **2013**, *15*, 3322–3325.

(253) Jung, B.; Park, K.; Song, K. H.; Lee, S. Continuous flow reactions in water for the synthesis of propargylamines *via* a metal-free decarboxylative coupling reaction. *Tetrahedron Lett.* **2015**, *56*, 4697–4700.

(254) Ghosh, S.; Biswas, K.; Bhattacharya, S.; Ghosh, P.; Basu, B. Effect of the ortho-hydroxy group of salicylaldehyde in the A³ coupling reaction: a metal-catalyst-free synthesis of propargylamine. *Beilstein J. Org. Chem.* **2017**, *13*, 552–557.

(255) Boys, M. L. A synthesis of the platelet aggregation inhibitor xemilofiban from *L*-aspartic acid. Confirmation of the absolute configuration. *Tetrahedron Lett.* **1998**, *39*, 3449–3450.

(256) He, Z.; Yudin, A. K. A Versatile Synthetic Platform Based on Strained Propargyl Amines. *Angew. Chem., Int. Ed.* **2010**, *49*, 1607–1610.

(257) Kano, T.; Yurino, T.; Asakawa, D.; Maruoka, K. Acid-catalyzed *in situ* generation of less accessible or unprecedented *N*-Boc imines from *N*-Boc aminals. *Angew. Chem., Int. Ed.* **2013**, *52*, 5532–5534.

(258) Kano, T.; Yurino, T.; Maruoka, K. Organocatalytic asymmetric synthesis of propargylamines with two adjacent stereocenters: Mannich-type reactions of *in situ* generated *C*-alkynyl imines with β -keto esters. *Angew. Chem., Int. Ed.* **2013**, *52*, 11509–11512.

(259) Kano, T.; Aota, Y.; Asakawa, D.; Maruoka, K. Brønsted acid-catalyzed Mannich reaction through dual activation of aldehydes and *N*-Boc-imines. *Chem. Commun.* **2015**, *51*, 16472–16474.

(260) Gomez-Bengoa, E.; Jimenez, J.; Lapuerta, I.; Mielgo, A.; Oiarbide, M.; Otazo, I.; Velilla, I.; Vera, S.; Palomo, C. Combined α,α -dialkylprolinol ether/Brønsted acid promotes Mannich reactions of aldehydes with unactivated imines. an entry to anti-configured propargylic amino alcohols. *Chem. Sci.* **2012**, *3*, 2949–2957.

(261) Wang, Y.; Mo, M.; Zhu, K.; Zheng, C.; Zhang, H.; Wang, W.; Shao, Z. Asymmetric synthesis of *syn*-propargylamines and unsaturated β -amino acids under Brønsted base catalysis. *Nat. Commun.* **2015**, *6*, 8544.

(262) Klauber, E. G.; De, C. K.; Shah, T. K.; Seidel, D. Merging nucleophilic and hydrogen bonding catalysis: an anion binding approach to the kinetic resolution of propargylic amines. *J. Am. Chem. Soc.* **2010**, *132*, 13624–13626.

(263) Kolleth, A.; Christoph, S.; Arseniyadis, S.; Cossy, J. Kinetic resolution of propargylamines *via* a highly enantioselective non-enzymatic *N*-acylation process. *Chem. Commun.* **2012**, *48*, 10511–10513.

(264) Messina, F.; Botta, M.; Corelli, F.; Schneider, M. P.; Fazio, F. Resolution of (\pm)-1-aryl-2-propynylamines *via* acyltransfer catalyzed by *Candida Antarctica* Lipase. *J. Org. Chem.* **1999**, *64*, 3767–3769.

(265) Castagnolo, D.; Armaroli, S.; Corelli, F.; Botta, M. Enantioselective synthesis of 1-aryl-2-propenylamines: a new approach to a stereoselective synthesis of the Taxol[®] side chain. *Tetrahedron: Asymmetry* **2004**, *15* (6), 941–949.

(266) Cossy, J.; Schmitt, A.; Cinquin, C.; Buisson, D.; Belotti, D. A very short, efficient and inexpensive synthesis of the prodrug form of SC-54701A a platelet aggregation inhibitor. *Bioorg. Med. Chem. Lett.* **1997**, *7*, 1699–1700.

(267) Topgi, R. S.; Ng, J. S.; Landis, B.; Wang, P.; Behling, J. R. Use of enzyme penicillin acylase in selective amidation/amide hydrolysis to resolve ethyl 3-amino-4-pentynoate isomers. *Bioorg. Med. Chem.* **1999**, *7*, 2221–2229.

(268) Landis, B. H.; Mullins, P. B.; Mullins, K. E.; Wang, P. T. Kinetic resolution of β -amino esters by acylation using immobilized penicillin amidohydrolase. *Org. Process Res. Dev.* **2002**, *6*, 539–546.

- (269) Schmidt, N. G.; Simon, R. C.; Kroutil, W. Biocatalytic asymmetric synthesis of optically pure aromatic propargylic amines employing ω -transaminases. *Adv. Synth. Catal.* **2015**, *357*, 1815–1821.
- (270) Aleku, G. A.; France, S. P.; Man, H.; Mangas-Sanchez, J.; Montgomery, S. L.; Sharma, M.; Leipold, F.; Hussain, S.; Grogan, G.; Turner, N. J. A reductive aminase from *Aspergillus oryzae*. *Nat. Chem.* **2017**, *9*, 961-969.
- (271) Gleiter, R.; Ritter, J. The palladium mediated conversion of 1,6 diazacyclodeca-3,8-diyne to 3,3'-bispyrroles. An unexpected reorganization of an alkyne π -system. *Tetrahedron* **1996**, *52*, 10383–10388.
- (272) Merkul, E.; Boersch, C.; Frank W.; Muller, T. J. Three-component synthesis of *N*-Boc-4-iodopyrroles and sequential one-pot alkynylation. *Org. Lett.* **2009**, *11*, 2269–2272.
- (273) Meng, T.-J.; Hu, Y.; Wang, S. Efficient construction of five-membered aromatic and nonaromatic heterocycles from 1,6-enynes by a palladium-catalyzed domino coupling/cycloisomerization process. *J. Org. Chem.* **2009**, *75*, 582–588.
- (274) Trost, B. M.; Lumb J.-P.; Azzarelli, J. M. An atom-economic synthesis of nitrogen heterocycles from alkynes. *J. Am. Chem. Soc.* **2011**, *133*, 740–743.
- (275) Sakai, N.; Hori, H.; Ogiwara, Y. Copper(II)-catalyzed [4+1] annulation of propargylamines with *N,O*-acetals: entry to the synthesis of polysubstituted pyrrole derivatives. *Eur. J. Org. Chem.* **2015**, 1905–1909.
- (276) Zheng, C.; Wang, Y.; Fan, R. Iodine(III)-mediated oxidative cross-coupling of enamines and propargylamines under metal-free conditions: an alternative way to prepare highly substituted 3-pyrrolines. *Org. Lett.* **2015**, *17*, 916–919.
- (277) Peng, H. M.; Zhao, J.; Li, X. Synthesis of trisubstituted pyrroles from rhodium-catalyzed alkyne head-to-tail dimerization and subsequent gold-catalyzed cyclization. *Adv. Synth. Catal.* **2009**, *351*, 1371–1377.

- (278) Saito, A.; Konishi, T.; Hanzawa, Y. Synthesis of pyrroles by gold(I)-catalyzed amino–Claisen rearrangement of *N*-propargyl enaminone derivatives. *Org. Lett.* **2009**, *12*, 372–374.
- (279) Yamamoto, Y.; Hayashi, H.; Saigoku, T.; Nishiyama, H. Domino coupling relay approach to polycyclic pyrrole-2-carboxylates. *J. Am. Chem. Soc.* **2005**, *127*, 10804–10805.
- (280) Campi, E. M.; Jackson, W. R.; Nilsson, Y. A hydroformylation route to β -substituted pyrroles. *Tetrahedron Lett.* **1991**, *32*, 1093–1094.
- (281) Dieltiens, N.; Moonen, K.; Stevens, C. V. Enyne metathesis-oxidation sequence for the synthesis of 2-phosphono pyrroles: proof of the “yne-then-ene” pathway. *Chem. Eur. J.* **2007**, *13*, 203–214.
- (282) Chachignon, H.; Scalacci, N.; Petricci, E.; Castagnolo, D. Synthesis of 1,2,3-substituted pyrroles from propargylamines *via* a one-pot tandem enyne cross metathesis–cyclization reaction. *J. Org. Chem.* **2015**, *80*, 5287–5295.
- (283) Castagnolo, D.; Botta, L.; Botta, M. Copper mediated alkyne-enoether cross-metathesis in aqueous medium: direct access to 3-substituted crotonaldehydes. *J. Org. Chem.* **2009**, *74*, 3172–3174.
- (284) Lee, M.; Moritomo, H.; Kanematsu, K. A new route to the isoindole nucleus *via* Furan–pyrrole ring-exchange. *J. Chem. Soc., Chem. Commun.* **1994**, 1535.
- (285) Cossy, J.; Poitevin, C.; Sallé, L.; Pardo, D. G. The thermal rearrangement of *N*-alkyl-*N*-vinylpropargylamines into 2-methylpyrroles. A new synthesis of annulated[*b*]pyrroles. *Tetrahedron Lett.* **1996**, *37*, 6709–6710.
- (286) Bremner, W. S.; Organ, M. G. Formation of substituted pyrroles *via* an imine condensation/aza-Claisen rearrangement/imine–allene cyclization process by MAOS. *J. Comb. Chem.* **2008**, *10*, 142–147.

- (287) Cacchi, S.; Fabrizi, G.; Filisti, E. *N*-Propargylic β -enaminones: common intermediates for the synthesis of polysubstituted pyrroles and pyridines. *Org. Lett.* **2008**, *10*, 2629–2632.
- (288) Zhao, Y. L.; Di, C. H.; Liu, S. D.; Meng, J.; Liu, Q. [3+2] Cycloaddition of propargylamines and α -acylketene dithioacetals: a synthetic strategy for highly substituted pyrroles. *Adv. Synth. Catal.* **2012**, *354*, 3545–3550.
- (289) Ren, C.-Q.; Di, C.-H.; Zhao, Y.-L.; Zhang, J.-P. [3+2] Cycloadditions of α -acyl ketene dithioacetals with propargylamines: pyrrole synthesis in water. *Tetrahedron Lett.* **2013**, *54*, 1478–1481.
- (290) Hu, Y.; Wang, C.; Wang, D.; Wu, F.; Wan, B. Synthesis of tetrasubstituted pyrroles from terminal alkynes and imines. *Org. Lett.* **2013**, *15*, 3146–3149.
- (291) Weng, J.; Chen, Y.; Yue, B.; Xu, M.; Jin, H. Synthesis of polysubstituted pyrroles from activated alkynes and *N*-propargylamines through base-catalyzed cascade reaction. *Eur. J. Org. Chem.* **2015**, 3164–3170.
- (292) Meng, J.; Li, Y.-J.; Zhao, Y.-L.; Bu, X.-B.; Liu, Q. A base-catalyzed cycloisomerization of 5-cyano-pentyne derivatives: an efficient synthesis of 3-cyano-4,5-dihydro-1H-pyrroles. *Chem. Commun.* **2014**, *50*, 12490–12492.
- (293) Jayaprakash, K.; Venkatachalam, C. S.; Balasubramanian, K. K. A convenient one-pot synthesis of *N*-aryl-3-pyrrolines. *Tetrahedron Lett.* **1999**, *40*, 6493–6496.
- (294) Castagnolo, D. *Targets in heterocyclic systems*; Italian Society of Chemistry: Eds. Attanasi, O. A.; Merino, P.; Spinelli, D. **2016**; p 222.
- (295) Kinoshita, A.; Sakakibara, N.; Mori, M. Novel 1,3-diene synthesis from alkyne and ethylene by ruthenium-catalyzed enyne metathesis. *Tetrahedron.* **1999**, *55*, 8155–8167.
- (296) Mori, M.; Sakakibara, N.; Kinoshita, A. Remarkable effect of ethylene gas in the intramolecular enyne metathesis of terminal alkynes. *J. Org. Chem.* **1998**, *63*, 6082–6083.

- (297) Yang, Q.; Alper, H.; Xiao, W.-J. Efficient method for the synthesis of chiral pyrrolidine derivatives *via* ring-closing enyne metathesis reaction. *Org. Lett.* **2007**, *9*, 769–771.
- (298) Boeda, F.; Clavier, H.; Jordaan, M.; Meyer, W. H.; Nolan, S. P. Phospha-bicyclononane-containing Ru complexes: efficient pre-catalysts for olefin metathesis reactions. *J. Org. Chem.* **2008**, *73*, 259-263.
- (299) Zhu, Z.-B.; Shi, M. Ruthenium-catalyzed tandem ring-opening/ring-closing/cross-metathesis of 1,6-cyclopropene-yne and olefins for the construction of the 3-pyrroline skeleton. *Org. Lett.* **2010**, *12*, 4462–4465.
- (300) Gavenonis, J.; Arroyo, R. V.; Snapper, M. L. Ruthenium-catalyzed tandem enyne metathesis/hydrovinylation. *Chem. Commun.* **2010**, *46*, 5692–5694.
- (301) Kitamura, T.; Mori, M. Ruthenium-catalyzed ring-opening and ring-closing enyne metathesis *Org. Lett.* **2001**, *3*, 1161–1164.
- (302) Randl, S.; Lucas, N.; Connon, S. J.; Blechert, S. A mechanism switch in enyne metathesis reactions involving rearrangement: influence of heteroatoms in the propargylic position. *Adv. Synth. Catal.* **2002**, *344*, 631–633.
- (303) Polindara-García L. A.; Miranda L. D. Two-step synthesis of 2,3-dihydropyrroles *via* a formal 5-*endo* cycloisomerization of Ugi 4-CR/propargyl adducts. *Org. Lett.* **2012**, *14*, 5408–5411.
- (304) Shin, Y. H.; Maheswara, M.; Hwang, J. Y.; Kang, E. J. Copper-catalyzed domino homologation and cycloisomerization reactions for 3-pyrroline synthesis. *Eur. J. Org. Chem.* **2014**, 2305–2311.
- (305) Ishida, T.; Kobayashi, R.; Yamada T. Novel method of tetramic acid synthesis: silver-catalyzed carbon dioxide incorporation into propargylic amine and intramolecular rearrangement. *Org. Lett.* **2014**, *16*, 2430–2433.

(306) Goutham, K.; Rao Mangina, N. S. V. M.; Suresh, S.; Raghavaiah, P.; Karunakar, G. V. Gold-catalysed cyclisation of *N*-propargylic β -enaminones to form 3-methylene-1-pyrroline derivatives. *Org. Biomol. Chem.* **2014**, *12*, 2869-2873.

(307) Clique, B.; Monteiro, N.; Balme, G. A one pot synthesis of various pyrrolidines *via* a tandem Michael addition-transition metal-catalyzed cyclization reaction. *Tetrahedron Lett.* **1999**, *40*, 1301–1304.

(308) Martinon, L.; Azoulay, S.; Monteiro, N.; Kündig, E. P.; Balme, G. Pd-catalyzed one-pot coupling of allylamines, activated alkenes, and unsaturated halides (or triflate): an atom efficient synthesis of highly functionalized pyrrolidines. *J. Organomet. Chem.* **2004**, *689*, 3831–3836.

(309) Azoulay, S.; Monteiro, N.; Balme, G. Three-component one-pot synthesis of functionalised (*Z*)-4-benzylidene (and alkenylidene) pyrrolidines. *Tetrahedron Lett.* **2002**, *43*, 9311–9314.

(310) Monterio, N.; Balme, G. Palladium-catalyzed reaction of propargyl nucleophiles with α -sulfonyl α,β -unsaturated ketones: a single-step synthesis of furo[3,4-*c*] heterocyclic derivatives. *J. Org. Chem.* **2000**, *65*, 3223–3226.

(311) Morikawa, S.; Yamazaki, S.; Furusaki, Y.; Amano, N.; Zenke, K.; Kakiuchi, K. Zinc- and indium-promoted conjugate addition-cyclization reactions of ethenetricarboxylates with propargylamines and alcohol: novel methylenepyrrolidine and methylenetetrahydrofuran syntheses. *J. Org. Chem.* **2006**, *71*, 3540–3544.

(312) Hanessian, S.; Leger, R. Expedient assembly of carbocyclic, heterocyclic, and polycyclic compounds by trimethylstannyl radical mediated carbocyclizations of dienes and trienes: a novel oxidative cleavage of the carbon-tin bond. *J. Am. Chem. Soc.* **1992**, *114*, 3115–3117.

- (313) Miura, K.; Saito, H.; Fujisawa, N.; Hosomi, A. Radical cyclization of 1,6-enynes using allylstannanes. *J. Org. Chem.* **2000**, *65*, 8119–8122.
- (314) Crich, D.; Shirai, M.; Rumthao, S. Enantioselective cyclization of alkene radical cations. *Org. Lett.* **2003**, *5*, 3767–3769.
- (315) Ojima, I.; Vu, A. T.; Lee, S. Y.; McCullagh, J. V.; Moralee, A. C.; Fujiwara, M.; Hoang, T. H. Rhodium-catalyzed silylcarbocyclization (SiCaC) and carbonylative silylcarbocyclization (CO-SiCaC) reactions of enynes. *J. Am. Chem. Soc.* **2002**, *124*, 9164–9174.
- (316) Kushwaha, K.; Malakar, C. C.; Stas, S.; Lemièrre, F.; Tehrani, K. A. Indium(III)-catalyzed tandem synthesis of 2-alkynyl-3,3-dichloropyrrolidines and their conversion to 3-chloropyrroles. *RSC Adv.* **2015**, *5*, 10139–10151.
- (317) Yasukouchi, T.; Kanematsu, K. An efficient approach to the basic skeleton of the cis-trikentrins. *J. Chem. Soc., Chem. Commun.* **1989**, 953–954.
- (318) Lin, H.; Kazmaier, U. Molybdenum-catalyzed α -hydrostannations of propargylamines as the key step in the synthesis of *N*-heterocycles. *Eur. J. Org. Chem.* **2009**, 1221–1227.
- (319) Pews-Davtyan, A.; Tillack, A.; Schmöle, A.-C.; Ortinau, S.; Frech, J. F.; Rolfs, A.; Beller, M. A new facile synthesis of 3-amidoindole derivatives and their evaluation as potential GSK-3 β inhibitors. *Org. Biomol. Chem.* **2010**, *8*, 1149–1153.
- (320) Liu, Y.; Huang, Y.; Song, H.; Liu, Y.; Wang, Q. Regio- and chemoselective *N*-1 acylation of indoles: Pd-catalyzed domino cyclization to afford 1,2-fused tricyclic indole scaffolds. *Chem. Eur. J.* **2015**, *21*, 5337–5340.
- (321) Hattori, G.; Miyake, Y.; Nishibayashi, Y. Copper-catalyzed diastereo- and enantioselective sequential reactions of propargylic acetates with (*E*)-2,4-pentadienylamine. *ChemCatChem* **2010**, *2*, 155–158.

- (322) Alcaide, B.; Almendros, P.; Alonso, J. M.; Fernández, I.; Gómez-Campillos, G.; Torres, M. R. A gold-catalysed imine-propargylamine cascade sequence: synthesis of 3-substituted-2,5-dimethylpyrazines and the reaction mechanism. *Chem. Commun.* **2014**, *50*, 4567–4570.
- (323) Su, J.; Liu, H.; Hua, R. Au(I)-catalyzed annulation of propargyl amine with aldehydes: one-pot cascade synthesis of 2,5-dimethylpyrazines. *Int. J. Mol. Sci.* **2015**, *16*, 3599–3608.
- (324) Chen, J.; Properzi, R.; Uccello, D. P.; Young, J. A.; Dushin, R. G.; Starr, J. T. One-pot oxidation and rearrangement of propargylamines and *in situ* pyrazole synthesis. *Org. Lett.* **2014**, *16*, 4146–4149.
- (325) Xin, X.; Wang, D.; Li, X.; Wan, B. One-pot synthesis of pyridines from 3-aza-1,5-enynes. *Tetrahedron*, **2013**, *69*, 10245–10248.
- (326) Xin, X.; Wang, D.; Wu, F.; Li, X.; Wan, B. Cyclization and *N*-iodosuccinimide-induced electrophilic iodocyclization of 3-aza-1,5-enynes to synthesize 1,2-dihydropyridines and 3-iodo-1,2-dihydropyridines. *J. Org. Chem.* **2013**, *78*, 4065–4074.
- (327) Karabiyikoglu, S.; Kelgokmen, Y.; Zora, M. Facile synthesis of iodopyridines from *N*-propargylic β -enaminones *via* iodine-mediated electrophilic cyclization. *Tetrahedron* **2015**, *71*, 4324–4333.
- (328) Cheng, G.; Weng, Y.; Yang, X.; Cui, X. Base-promoted *N*-pyridylation of heteroarenes using *N*-propargyl enaminones as equivalents of pyridine scaffolds. *Org. Lett.* **2015**, *17*, 3790–3793.
- (329) Abbiati, G.; Arcadi, A.; Bianchi, G.; Di Giuseppe, S.; Marinelliand, F.; Rossi, E. Sequential amination/annulation/aromatization reaction of carbonyl compounds and propargylamine: a new one-pot approach to functionalized pyridines. *J. Org. Chem.* **2003**, *68*, 6959–6966.

(330) Wei, H.; Li, Y.; Xiao, K.; Cheng, B.; Wang, H.; Hu, L.; Zhai, H. Synthesis of polysubstituted pyridines *via* a one-pot metal-free strategy. *Org. Lett.* **2015**, *17*, 5974–5977.

(331) Fañanas, F. J.; Arto, T.; Mendoza, A.; Rodriguez, F. Synthesis of 2,5-dihydropyridine derivatives by gold-catalyzed reactions of β -ketoesters and propargylamines. *Org. Lett.* **2011**, *13*, 4184–4187.

(332) Martins, M. A.; Rossatto, M.; Frizzo, C. P.; Scapin, E.; Buriol, L.; Zanatta, N.; Bonacorso, H. G. Intramolecular cyclization of *N*-propargylic β -enaminones catalyzed by silver. *Tetrahedron Lett.* **2013**, *54*, 847–849.

(333) Mizoguchi, H.; Watanabe, R.; Minami, S.; Oikawa, H.; Oguri, H. Synthesis of multiply substituted 1,6-dihydropyridines through Cu(I)-catalyzed 6-*endo* cyclization. *Org. Biomol. Chem.* **2015**, *13*, 5955–5963

(334) Kim, H.; Lee, C. Rhodium-catalyzed cycloisomerization of *N*-propargyl enamine derivatives. *J. Am. Chem. Soc.* **2006**, *128*, 6336–6337.

(335) Undeela, S.; Thadkapally, S.; Nanubolu, J. B.; Singarapu, K. K.; Menon, R. S. Catalyst-controlled divergence in cycloisomerisation reactions of *N*-propargyl-*N*-vinyl sulfonamides: gold-catalysed synthesis of 2-sulfonylmethyl pyrroles and dihydropyridines. *Chem. Commun.* **2015**, *51*, 13748–13751.

(336) Zhang, X.; Xu, X.-M.; Zhao, L.; You, J.; Zhu, J.; Wang, M.-X. Synthesis of diverse di- to penta-substituted 1,2-dihydropyridine derivatives from gold(I)-catalyzed intramolecular addition of tertiary enamides to alkynes. *Tetrahedron Lett.* **2015**, *56*, 3898–3901

(337) Li, Y.; Wu, Z.; Pan, Y.; Huang, H.; Shi, J.; Bu, H.; Ma, H.; Liang, Y.; Huang, B. Gold(I)-catalyzed oriented assembly of dihydropyridines. *Synlett* **2015**, *26*, 834–838.

(338) Taguchi, T.; Imahori, T.; Yoshimura, Y.; Kato, A.; Adachi, I.; Kawahata, M.; Yamaguchi, K.; Takahata, H. Asymmetric synthesis of 2-propylisofagomine using allylic hydroxy group accelerated ring-closing enyne metathesis. *Heterocycles* **2012**, *84*, 929–944

(339) Imahori, T.; Ojima, H.; Yoshimura, Y.; Takahata, H. Acceleration effect of an allylic hydroxy group on ring-closing enyne metathesis of terminal alkynes: scope, application, and mechanistic insights. *Chem. Eur. J.* **2008**, *14*, 10762–10771.

(340) Kotha, S.; Khedkar, P. Synthesis of a conformationally constrained phenylalanine derivative by a strategic combination of ring-closing enyne metathesis and Diels-Alder reaction. *Synthesis* **2008**, 2925–2928.

(341) Katritzky, A. R.; Nair, S. K.; Khokhlova, T.; Akhmedov, N. G. Efficient synthesis of enynecarbamates and their ring-closing metathesis/[4+2] Diels–Alder cycloaddition: synthesis of hexahydroisoquinolines. *J. Org. Chem.* **2003**, *68*, 5724–5727.

(342) Lebold, T. P.; Leduc, A. B.; Kerr, M. A. Zn(II)-catalyzed synthesis of piperidines from propargyl amines and cyclopropanes. *Org. Lett.* **2009**, *11*, 3770–3772.

(343) Huma, H. S.; Halder, R.; Kalra, S. S.; Das, J.; Iqbal, J. Cu(I)-catalyzed three component coupling protocol for the synthesis of quinoline derivatives. *Tetrahedron Lett.* **2002**, *43*, 6485–6488.

(344) Xiao, F.; Chen, Y.; Liu, Y.; Wang, J. Sequential catalytic process: synthesis of quinoline derivatives by AuCl₃/CuBr-catalyzed three-component reaction of aldehydes, amines, and alkynes. *Tetrahedron* **2008**, *64*, 2755–2761.

(345) Zhu, M.; Fu, W.; Zou, G.; Xun, C.; Deng, D.; Ji, B. An efficient synthesis of 2-trifluoromethyl quinolines via gold-catalyzed cyclization of trifluoromethylated propargylamines. *J. Fluorine Chem.* **2012**, *135*, 195–199.

(346) Symeonidis, T. S.; Lykakis, I. N.; Litinas, K. E. Synthesis of quinolines and fused pyridocoumarins from *N*-propargylanilines or propargylaminocoumarins by catalysis with gold nanoparticles supported on TiO₂. *Tetrahedron* **2013**, *69*, 4612–4616.

- (347) Roy, B.; Ansary, I.; Samanta, S.; Majumdar, K. Synthesis of substituted quinolines from *N*-aryl-*N*-(2-alkynyl)toluenesulfonamides via FeCl₃-mediated intramolecular cyclization and concomitant detosylation. *Tetrahedron Lett.* **2012**, *53*, 5119–5122.
- (348) Aichhorn, S.; Himmelsbach, M.; Schöfberger, W. Synthesis of quinoxalines or quinolin-8-amines from *N*-propargyl aniline derivatives employing tin and indium chlorides. *Org. Biomol. Chem.* **2015**, *13*, 9373–9380.
- (349) Huang, H.; Jiang, H.; Chen, K.; Liu, H. A simple and convenient copper-catalyzed tandem synthesis of quinoline-2-carboxylates at room temperature. *J. Org. Chem.* **2009**, *74*, 5476–5480.
- (350) Meyet, C. E.; Larsen, C. H. One-step catalytic synthesis of alkyl-substituted quinolines. *J. Org. Chem.* **2014**, *79*, 9835–9841.
- (351) Cao, K.; Zhang, F.M.; Tu, Y.Q.; Zhuo, X.T.; Fan, C.A. Iron(III)-catalyzed and air-mediated tandem reaction of aldehydes, alkynes and amines: an efficient approach to substituted quinolines. *Chem. Eur. J.* **2009**, *15*, 6332–6334.
- (352) Zhang, L.; Wu, B.; Zhou, Y.; Xia, J.; Zhou, S.; Wang, S. Rare-earth metal chlorides catalyzed one-pot syntheses of quinolines under solvent-free microwave irradiation conditions. *Chin. J. Chem.* **2013**, *31*, 465–471.
- (353) Fasano, V.; Radcliffe, J. E.; Ingleson, M. J. Mechanistic insights into the B(C₆F₅)₃-initiated aldehyde-aniline-alkyne reaction to form substituted quinolines. *Organometallics* **2017**, *36*, 1623-1629.
- (354) Kulkarni, A.; Török, B. Microwave-assisted multicomponent domino cyclization–aromatization: an efficient approach for the synthesis of substituted quinolines. *Green Chem.* **2010**, *12*, 875–878.

- (355) Guchhait, S. K.; Jadeja, K.; Madaan, C. A new process of multicomponent Povarov reaction–aerobic dehydrogenation: synthesis of polysubstituted quinolines. *Tetrahedron Lett.* **2009**, *50*, 6861–6865.
- (356) Zhang, L.; Chen, S.; Gao, Y.; Zhang, P.; Wu, Y.; Tang, G.; Zhao, Y. *tert*-Butyl hydroperoxide mediated cascade synthesis of 3-arylsulfonylquinolines. *Org. Lett.* **2016**, *18*, 1286–1289.
- (357) Zhang, X.; Yao, T.; Campo, M. A.; Larock, R. C. Synthesis of substituted quinolines by the electrophilic cyclization of *n*-(2-alkynyl)anilines. *Tetrahedron* **2010**, *66*, 1177–1187.
- (358) Williamson, N. M.; March, D. R.; Ward, A. D. An improved synthesis of 2,2-disubstituted-1,2-dihydroquinolines and their conversion to 3-chloro-2,2-disubstituted-tetrahydroquinolines. *Tetrahedron Lett.* **1995**, *36*, 7721–7724.
- (359) Williamson, N.M.; Ward, A.D. The preparation and some chemistry of 2,2-dimethyl-1,2-dihydroquinolines. *Tetrahedron* **2005**, *61*, 155–165.
- (360) Komeyama, K.; Igawa, R.; Takaki, K. Cationic iron-catalyzed intramolecular alkyne-hydroarylation with electron-deficient arenes. *Chem. Commun.* **2010**, *46*, 1748–1750.
- (361) Eom, D.; Mo, J.; Lee, P.H.; Gao, Z.; Kim, S. Synthesis of vinyl sulfides and vinylamines through catalytic intramolecular hydroarylation in the presence of FeCl₃ and AgOTf. *Eur. J. Org. Chem.* **2013**, *3*, 533–540.
- (362) Ryu, J.-S. Hydroarylation for the facile synthesis of 2-substituted tetrahydroquinoline: a concise synthesis of (+)-(*S*)-angustureine. *Bull. Korean Chem. Soc.* **2006**, *27*, 631–632.
- (363) Moran-Poladura, P.; Suarez-Pantiga, S.; Piedrafita, M.; Rubio, E.; Gonzalez, J. M. Regiocontrolled gold(I)-catalyzed cyclization reactions of *N*-(3-iodoprop-2-ynyl)-*N*-tosylanilines. *J. Organomet. Chem.* **2011**, *696*, 12–15.

(364) Gurunathan, S.; Perumal, P. T. Synthesis of novel 3-bromo-1,2-dihydroquinolines via palladium mediated intramolecular cyclization of *N*-tosyl-*N*-propargyl anilines. *Tetrahedron Lett.* **2011**, *52*, 1783–1787.

(365) Jalal, S.; Bera, K.; Sarkar, S.; Paul, K.; Jana, U. Efficient synthesis of functionalized dihydroquinolines, quinolines and dihydrobenzo[*b*]azepine via an iron(III) chloride-catalyzed intramolecular alkyne–carbonyl metathesis of alkyne tethered 2-amino benzaldehyde/acetophenone derivatives. *Org. Biomol. Chem.* **2014**, *12*, 1759–1770.

(366) Yang, Q.; Xu, T. Yu, Z. Iron-mediated carboarylation/cyclization of propargylanilines with acetals: a concise route to indeno[2,1-*c*]quinolines. *Org. Lett.* **2014**, *16*, 6310–6313.

(367) Tseng, M.-C.; Chu, Y.-W.; Tsai, H.-P.; Lin, C.-M.; Hwang, J. Chu, Y.-H. One-pot synthesis of luotonin A and its analogues. *Org. Lett.* **2011**, *13*, 920–923.

(368) Almansour, A. I.; Arumugam, N.; Kumar, R. S.; Menendez, J. C.; Ghabbour, H. A.; Fun, H.-K.; Kumar, R.R. Straightforward synthesis of pyrrolo[3,4-*b*]quinolines through intramolecular Povarov reactions. *Tetrahedron Lett.* **2015**, *56*, 6900–6903.

(369) Bogentoft, C.; Ericsson, O.; Danielsson, B. Base-catalysed cyclizations of some acetylenic oxoquinazolines and related open amides. *Acta Chem. Scand.* **1971**, *25*, 551–558.

(370) Nilsson, B. M.; Hacksell, U. Base-catalyzed cyclization of *N*-propargylamides to oxazoles. *J. Heterocycl. Chem.* **1989**, *26*, 269–275.

(371) Nilsson, B. M.; Vargas, H. M.; Ringdahl, B.; Hacksell, U. Phenyl-substituted analogs of oxotremorine as muscarinic antagonists. *J. Med. Chem.* **1992**, *35*, 285–294.

(372) Wipf, P.; Rahman, L. T.; Rector, S. R. A general strategy for five-membered heterocycle synthesis by cycloelimination of alkynyl ketones, amides, and thioamides. *J. Org. Chem.* **1998**, *63*, 7132–7133.

- (373) Yu, X.; Xin, X.; Wan, B.; Li, X. Base-catalyzed cyclization of *N*-sulfonyl propargylamides to sulfonylmethyl-substituted oxazoles *via* sulfonyl migration. *J. Org. Chem.* **2013**, *78*, 4895–4904.
- (374) Street, L. J.; Baker, R.; Castro, J. L.; Chambers, M. S.; Guiblin, A. R.; Hobbs, S. C.; Matassa, V. G.; Reeve, A. J.; Beer, M. S. Synthesis and serotonergic activity of 5-(oxadiazolyl)tryptamines: potent agonists for 5-HT_{1D} receptors. *J. Med. Chem.* **1993**, *36*, 1529–1538.
- (375) Arcadi, A.; Cacchi, S.; Cascia, L.; Fabrizi, G.; Marinelli, F. Preparation of 2,5-disubstituted oxazoles from *N*-propargylamides. *Org. Lett.* **2001**, *3*, 2501–2504.
- (376) Bacchi, A.; Costa, M.; Gabriele, B.; Pelizzi, G.; Salerno, G. Efficient and general synthesis of 5-(alkoxycarbonyl)methylene-3-oxazolines by palladium-catalyzed oxidative carbonylation of prop-2-ynylamides. *J. Org. Chem.* **2002**, *67*, 4450–4457.
- (377) Beccalli, E. M.; Borsini, E.; Brogini, G.; Palmisano, G.; Sottocornola, S. Intramolecular Pd(II)-catalyzed cyclization of propargylamides: straightforward synthesis of 5-oxazolecarbaldehydes. *J. Org. Chem.* **2008**, *73*, 4746–4749.
- (378) Saito, A.; Iimura, K.; Hanzawa, Y. Synthesis of oxazoles through Pd-catalyzed cycloisomerization-allylation of *N*-propargylamides with allyl carbonates. *Tetrahedron Lett.* **2010**, *51*, 1471–1474.
- (379) Yasuhara, S.; Sasa, M.; Kusakabe, T.; Takayama, H.; Kimura, M.; Mochida, T.; Kato, K. Cyclization-carbonylation-cyclization coupling reactions of propargyl acetates and amides with palladium(II)-bisoxazoline catalysts. *Angew. Chem., Int. Ed.* **2011**, *50*, 3912–3915.
- (380) Mali, J. K.; Takale, B. S.; Telvekar, V. N. Readily switchable one-pot 5-*exo*-dig cyclization using a palladium catalyst. *RSC Adv.* **2017**, *7*, 2231–2235.

(381) Milton, M. D.; Inada, Y.; Nishibayashi, Y.; Uemura, S. Ruthenium- and gold-catalysed sequential reactions: a straightforward synthesis of substituted oxazoles from propargylic alcohols and amides. *Chem. Commun.* **2004**, *23*, 2712–2713.

(382) Hashmi, A. S. K.; Weyrauch, J. P.; Frey, W.; Bats, J. W. Gold catalysis: mild conditions for the synthesis of oxazoles from *N*-propargyl carboxamides and mechanistic aspects. *Org. Lett.* **2004**, *6*, 4391–4394.

(383) Verniest, G.; Padwa, A. Gold- and silver-mediated cycloisomerizations of *N*-propargylamides. *Org. Lett.* **2008**, *10*, 4379–4382.

(384) Weyrauch, J. P.; Hashmi, A. S. K.; Schuster, A.; Hengst, T.; Schetter, S.; Littmann, A.; Rudolph, M.; Hamzic, M.; Visus, J.; Rominger, F.; Wolfgang, F.; Jan, W. B. Cyclization of propargylic amides: mild access to oxazole derivatives. *Chem. Eur. J.* **2010**, *16*, 956–963.

(385) Tran-Dubé, M.; Johnson, S.; McAlpine, I. A two-step, one-pot procedure using acid chlorides and propargyl amines to form tri-substituted oxazoles *via* gold-catalyzed cyclization. *Tetrahedron Lett.* **2013**, *54*, 259–261.

(386) Timoshenko, M. A.; Ayusheev, A. B.; Kharitonov, Y. V.; Shakirov, M. M.; Shul'ts, E. E. Synthetic transformations of higher terpenoids. XXXIV. Preparation of carboxyl derivatives of isopimaric acid. *Chem. Nat. Compd.* **2014**, *50*, 673–680.

(387) Shen, Y.; Zificsak, C. A.; Shea, J. E.; Lao, X.; Bollt, O.; Li, X.; Lisko, J. G.; Theroff, J. P.; Scaife, C. L.; Ator, M. A.; Ruggeri, B. A.; Dorsey, B. D.; Kuwada, S. K. Design, synthesis, and biological evaluation of sulfonyl acrylonitriles as novel inhibitors of cancer metastasis and spread. *J. Med. Chem.* **2015**, *58*, 1140–1158.

(388) Hashmi, A. S. K.; Schuster, A. M.; Schmuck, M.; Rominger, F. Gold-catalyzed cyclization of nonterminal propargylic amides to substituted alkylideneoxazolines and -oxazines. *Eur. J. Org. Chem.* **2011**, *24*, 4595–4602.

(389) Orbisaglia, S.; Jacques, B.; Braunstein, P.; Hueber, D.; Pale, P.; Blanc, A.; de Frémont, P. Synthesis, characterization, and catalytic activity of cationic NHC gold(III) pyridine complexes. *Organometallics* **2013**, *32*, 4153–4164.

(390) Doherty, S.; Knight, J. G.; Perry, D. O.; Ward, N. A. B.; Bittner, D. M.; McFarlane, W.; Wills, C.; Probert, M. R. Triaryl-like MONO-, BIS-, and TRISKITPHOS phosphines: synthesis, solution NMR studies, and a comparison in gold-catalyzed carbon-heteroatom bond forming 5-*exo*-dig and 6-*endo*-dig cyclizations. *Organometallics* **2016**, *35*, 1265–1278.

(391) Wang, D.; Cai, R.; Sharma, S.; Jirak, J.; Thummanapelli, S. K.; Akhmedov, N. G.; Zhang, H.; Liu, X.; Petersen, J. L.; Shi, X. “Silver effect” in gold(I) catalysis: an overlooked important factor. *J. Am. Chem. Soc.* **2012**, *134*, 9012–9019.

(392) Hu, Y.; Yi, R.; Wu, F.; Wan, B. Synthesis of functionalized oxazoles *via* silver-catalyzed cyclization of propargylamides and allenylamides. *J. Org. Chem.* **2013**, *78*, 7714–7726.

(393) Senadi, G. C.; Hu, W.-P.; Hsiao, J.-S.; Vandavasi, J. K.; Chen, C.-Y.; Wang, J.-J. Facile, selective, and regiocontrolled synthesis of oxazolines and oxazoles mediated by ZnI₂ and FeCl₃. *Org. Lett.* **2012**, *14*, 4478–4481.

(394) Wang, B.; Chen, Y.; Zhou, L.; Wang, J.; Tung, C.-H.; Xu, Z. Synthesis of oxazoles by tandem cycloisomerization/allylic alkylation of propargyl amides with allylic alcohols: Zn(OTf)₂ as π acid and σ acid catalyst. *J. Org. Chem.* **2015**, *80*, 12718–12724.

(395) Odabachian, Y.; Wang, Q.; Zhu, J. Tertiary amines as synthetic equivalents of vinyl cations: zinc bromide promoted coupling of propargylamines with α -isocyanoacetamides to give 2,4,5-trisubstituted oxazoles initiated by an internal redox process. *Chem. Eur. J.* **2013**, *19*, 12229–12233.

(396) Wilkins, L. C.; Wieneke, P.; Newman, P. D.; Kariuki, B. M.; Rominger, F.; Hashmi, A. S. K.; Hansmann, M. M.; Melen, R. L. Pathways to functionalized heterocycles: propargyl rearrangement using $B(C_6F_5)_3$. *Organometallics* **2015**, *34*, 5298–5309.

(397) Bondarenko, N. A.; Vas'kevich, A. I.; Bol'but, A. V.; Rusanov, E. B.; Vovk, M. V. Electrophilic cyclization of *N*-allyl(propargyl)-5-amino-1*H*-pyrazole-4-carboxamides. Synthesis of 4-[(dihydro)oxazol-2-yl]-1*H*-pyrazol-5-amines. *Russ. J. Org. Chem.* **2015**, *51*, 1774–1783.

(398) Bartoli, G.; Cimarelli, C.; Cipolletti, R.; Diomed, S.; Giovannini, R.; Mari, M.; Marsili, L.; Marcantoni, E. Microwave-assisted cerium(III)-promoted cyclization of propargyl amides to polysubstituted oxazole derivatives. *Eur. J. Org. Chem.* **2012**, *3*, 630–636.

(399) Wipf, P.; Aoyama, Y.; Benedum, T. E. A practical method for oxazole synthesis by cycloisomerization of propargyl amides. *Org. Lett.* **2004**, *6*, 3593–3595.

(400) Saito, A.; Matsumoto, A.; Hanzawa, Y. PIDA-mediated synthesis of oxazoles through oxidative cycloisomerization of propargylamides. *Tetrahedron Lett.* **2010**, *51*, 2247–2250.

(401) Hu, Y.; Yi, R.; Wang, C.; Xin, X.; Wu, F.; Wan, B. From propargylamides to oxazole derivatives: NIS-mediated cyclization and further oxidation by dioxygen. *J. Org. Chem.* **2014**, *79*, 3052–3059.

(402) Wachenfeldt, H. v.; Paulsen, F.; Sundin, A.; Strand, D. Synthesis of substituted oxazoles from *N*-benzyl propargyl amines and acid chlorides. *Eur. J. Org. Chem.* **2013**, *21*, 4578–4585.

(403) Venkatesha, N. J.; Bhat, Y. S.; Jai Prakash, B. S. Manifestation of zeolitic pore characteristics of modified montmorillonite in oxazole synthesis by propargylation and cycloisomerization reactions. *Appl. Catal. A Gen.* **2015**, *496*, 51–57.

- (404) Costa, M.; Chiusoli, G. P.; Rizzardi, M. Base-catalysed direct introduction of carbon dioxide into acetylenic amines. *Chem. Commun.* **1996**, *14*, 1699-1700.
- (405) Costa, M.; Chiusoli, G. P.; Taffurelli, D.; Dalmonago, G. Superbase catalysis of oxazolidin-2-one ring formation from carbon dioxide and prop-2-yn-1-amines under homogeneous or heterogenous conditions. *J. Chem. Soc. Perkin Trans. 1* **1998**, 1541–1546.
- (406) Shi, M.; Shen, Y.-M. Transition-metal-catalyzed reactions of propargylamine with carbon dioxide and carbon disulfide. *J. Org. Chem.* **2002**, *67*, 16–21.
- (407) Brunel, P.; Monot, J.; Kefalidis, C. E.; Maron, L.; Martin-Vaca, B.; Bourissou, D. Valorization of CO₂: preparation of 2-oxazolidinones by metal / ligand cooperative catalysis with SCS indenediide Pd complexes. *ACS Catal.* **2017**, *7*, 2652–2660
- (408) Yoshida, S.; Fukui, K.; Kikuchi, S.; Yamada, T. Silver-catalyzed preparation of oxazolidinones from carbon dioxide and propargylic amines *Chem. Lett.* **2009**, *38*, 786–787.
- (409) Hase, S.; Kayaki, Y.; Ikariya, T. Mechanistic aspects of the carboxylative cyclization of propargylamines and carbon dioxide catalyzed by gold(I) complexes bearing an *N*-heterocyclic carbene ligand. *ACS Catal.* **2015**, *5*, 5135–5140.
- (410) Yuan, R.; Lin, Z. Mechanistic insight into the gold-catalyzed carboxylative cyclization of propargylamines. *ACS Catal.* **2015**, *5*, 2866–2872.
- (411) Fujita, K.-i.; Inoue, K.; Sato, J.; Tsuchimoto, T.; Yasuda, H. Carboxylative cyclization of propargylic amines with CO₂ catalyzed by dendritic *N*-heterocyclic carbene-gold(I) complexes. *Tetrahedron* **2016**, *72*, 1205–1212.
- (412) Wang, M.-Y.; Song, Q.-W.; Ma, R.; Xie, J.-N.; He, L.-N. Efficient conversion of carbon dioxide at atmospheric pressure to 2-oxazolidinones promoted by bifunctional Cu(II)-substituted polyoxometalate-based ionic liquids. *Green Chem.* **2016**, *18*, 282–287.

- (413) Liu, X.; Wang, M.-Y.; Wang, S.-Y.; Wang, Q.; He, L.-N. *In situ* generated zinc(II) catalyst for incorporation of CO₂ into 2-oxazolidinones with propargylic amines at atmospheric pressure. *ChemSusChem* **2016**, *10*, 1210–1216.
- (414) García-Domínguez, P.; Fehr, L.; Rusconi, G.; Nevado, C. Palladium-catalyzed incorporation of atmospheric CO₂: efficient synthesis of functionalized oxazolidinones. *Chem. Sci.* **2016**, *7*, 3914–3918.
- (415) Kayaki, Y.; Yamamoto, M.; Suzukia, T.; Ikariya, T. Carboxylative cyclization of propargylamines with supercritical carbon dioxide. *Green Chem.* **2006**, *8*, 1019-1021.
- (416) Basolo, L.; Beccalli, E. M.; Borsini, E.; Broggin, G.; Pellegrino, S. *N,N*-Disubstituted propargylamines as tools in the sequential 1,3-dipolar cycloaddition/arylation processes to the formation of polyheterocyclic systems. *Tetrahedron* **2008**, *64*, 8182–8187.
- (417) Yermolina, M. V.; Wang, J.; Caffrey, M.; Rong, L. L.; Wardrop, D. J. Discovery, synthesis, and biological evaluation of a novel group of selective inhibitors of filoviral entry. *J. Med. Chem.* **2011**, *54*, 765–781.
- (418) Babulreddy, A.; Hymavathi, R. V.; Hussain, M. M.; Narayana Swamy, G. Synthesis, characterization, and *in vitro* antimicrobial activity of methyleneamine-linked bis-heterocycles. *J. Heterocycl. Chem.* **2013**, *50*, 727–733.
- (419) Debleds, O.; Dal Zotto, C.; Vrancken, E.; Campagne, J.-M.; Retailleau, P. A dual gold-iron catalysis for a one-pot synthesis of 2,3-dihydroisoxazoles from propargylic alcohols and *N*-protected hydroxylamines. *Adv. Synth. Catal.* **2009**, *351*, 1991–1998.
- (420) Debleds, O.; Gayon, E.; Ostaszuk, E.; Vrancken, E.; Campagne, J.-M. A versatile iron-catalyzed protocol for the one-pot synthesis of isoxazoles or isoxazolines from the same propargylic alcohols. *Chem. Eur. J.* **2010**, *16*, 12207 – 12213.
- (421) Batty, J. W.; Weedon, B. C. L. Acetylene reactions. Part III. Reaction of aminobutynes with carbon disulphide. *J. Chem. Soc.* **1949**, 786-789.

- (422) Hanefeld, W.; Bercin, E. Alkylation, acylation, and carbamoylation products of 5-methylene-1,3-thiazolidine-2-thione. *Liebigs Ann. der Chemie* **1985**, *1*, 58–64.
- (423) Heugebaert, T. S. A.; Vervaecke, L. P. D.; Stevens, C. V. Gold(III) chloride catalysed synthesis of 5-alkylidene-dihydrothiazoles. *Org. Biomol. Chem.* **2011**, *9*, 4791–4794.
- (424) Novikov, R. V.; Danilkina, N. A.; Balova, I. A. Cyclocondensation of *N*-(prop-2-yn-1-yl)- and *N*-(penta-2,4-diyne-1-yl)-*o*-phenylenediamines with phenyl isothiocyanate and carbon disulfide. *Chem. Heterocycl. Compd.* **2011**, *47*, 758–766.
- (425) Mahdavi, M.; Bialam, M.; Saeedi, M.; Jafarpour, F.; Foroumadi, A.; Shafiee, A. Efficient synthesis of 2-methylenethiazolo[2,3-*b*]quinazolinone derivatives. *Synlett* **2015**, *26*, 173–176.
- (426) Nechaev, A. A.; Peshkov, A. A.; Van Hecke, K.; Peshkov, V. A.; Van der Eycken, E. V. Synthesis of thiazolidine-2-thiones through a one-pot A³-coupling-carbon disulfide incorporation process. *Eur. J. Org. Chem.* **2017**, *6*, 1063–1069.
- (427) Easton, N. R.; Cassady, D. R.; Dillard, R. D. Reactions of acetylenic amines. VIII. Cyclization of acetylenic ureas. *J. Org. Chem.* **1964**, *29*, 1851–1855.
- (428) Eloy, F.; Deryckere, A. The utilization of propargylamine in heterocyclic synthesis. Preparation of oxazoles, thiazoles and imidazoles. *Chim. Ther.* **1973**, *8*, 437–446.
- (429) Urleb, U.; Neidlein, R.; Kramer, W. Synthesis of thiazole and fused thiazolo derivatives. *Helv. Chim. Acta* **1993**, *76*, 431–440.
- (430) Vrasidas, I.; Kemmink, J.; Liskamp, R. M. J.; Pieters, R. J. Synthesis and cholera toxin binding properties of a lactose-2-aminothiazoline conjugate. *Org. Lett.* **2002**, *4*, 1807–1808.
- (431) Sasmal, P. K.; Chandrasekhar, A.; Sridhar, S.; Iqbal, J. Novel one-step method for the conversion of isothiocyanates to 2-alkyl(aryl)aminothiazoles. *Tetrahedron* **2008**, *64*, 11074–11080.

- (432) Huang, S.; Shao, Y.; Liu, R.; Zhou, X. Facile access to oxazolidin-2-imine, thiazolidin-2-imine and imidazolidin-2-imine derivatives bearing an exocyclic haloalkylene via direct halocyclization between propargylamines, heterocumulenes and I₂ (NBS). *Tetrahedron* **2015**, *71*, 4219–4226.
- (433) Madaan, C.; Saraf, S.; Priyadarshani, G.; Reddy, P. P.; Guchhait, S. K.; Kunwar, A. C.; Sridhar, B. One-pot, three-step copper-catalyzed five-/four-component reaction constructs polysubstituted oxa(thia)zolidin-2-imines. *Synlett* **2012**, *23*, 1955–1959.
- (434) Castillo Gomez, J. D.; Balcazar, E.; Hagenbach, A.; Noufele, C. N.; Abram, U. Benzoylamido-substituted thiazoles and thiazolidines and their rhenium complexes. *Polyhedron* **2016**, *117*, 293–299.
- (435) Viart, H. M.-F.; Larsen, T. S.; Tassone, C.; Andresen, T. L.; Clausen, M. H. Propargylamine-isothiocyanate reaction: efficient conjugation chemistry in aqueous media. *Chem. Commun.* **2014**, *50*, 7800–7802.
- (436) Vincent-Rocan, J.-F.; Derasp, J. S.; Beauchemin, A. M. Diversity-oriented heterocyclic synthesis using divergent reactivity of *N*-substituted iso(thio)cyanates. *Chem. Commun.* **2015**, *51*, 16405–16408.
- (437) Castagnolo, D.; Pagano, M.; Bernardini, M.; Botta, M. Domino alkylation-cyclization reaction of propargyl bromides with thioureas/thiopyrimidinones: a new facile synthesis of 2-aminothiazoles and 5*H*-thiazolo[3,2-*a*]pyrimidin-5-ones *Synlett* **2009**, 2093-2096.
- (438) Radi, M.; Pagano, M.; Franchi, L.; Castagnolo, D.; Schenone, S.; Casaluce, G.; Zamperini, C.; Dreassi, E.; Maga, G.; Samuele, A.; Gonzalo, E.; Clotet, B.; Esté, J. A.; Botta, M. Synthesis, biological activity, and ADME properties of novel S-DABOs/N-DABOs as HIV reverse transcriptase inhibitors. *ChemMedChem* **2012**, *7*, 883-896.

- (439) Scalacci, N.; Pelloja, C.; Radi, M.; Castagnolo, D. Microwave-assisted domino reactions of propargylamines with isothiocyanates: selective synthesis of 2-aminothiazoles and 2-amino-4-methylenethiazolines. *Synlett* **2016**, *27*, 1883–1887.
- (440) Short, K. M.; Ziegler, C. B., Jr. An addition-elimination strategy for synthesis of oxazoles. *Tetrahedron Lett.* **1993**, *34*, 71–74.
- (441) Chandrasekharam, M.; Singh, O. M.; Ila, H.; Junjappa, H. Reaction of β -oxodithioesters with propargylamine: a facile entry to novel 2-(acylalkylidene)-5-(methylene)thiazolidines. *Synth. Commun.* **1998**, *28*, 3073–3079.
- (442) Sasmal, P. K.; Sridhar, S.; Iqbal, J. Facile synthesis of thiazoles *via* an intramolecular thia-Michael strategy. *Tetrahedron Lett.* **2006**, *47*, 8661–8665.
- (443) Yarovenko, V.; Polushina, A.; Zavarzin, I.; Krayushkin, M.; Kotovskaya, S.; Charushin, V. Synthesis of dihydrothiazoles and thiazoles based on monothiooxamides. *J. Sulfur Chem.* **2009**, *30*, 327–337.
- (444) Maddani, M.; Prabhu, K. R. A Convenient method for the synthesis of substituted thioureas. *Tetrahedron Lett.* **2007**, *48*, 7151–7154.
- (445) Meng, X.; Kim, S. Tungsten and molybdenum catalyst-mediated cyclisation of *N*-propargyl amides. *Org. Biomol. Chem.* **2011**, *9*, 4429–4431.
- (446) Alhalib, A.; Moran, W. J. CuI-catalyzed cycloisomerization of propargyl amides. *Org. Biomol. Chem.* **2014**, *12*, 795–800.
- (447) Urbanaitė, A.; Jonušis, M.; Bukšnaitienė, R.; Balkaitis, S.; Čikotienė, I. Electrophile-Mediated Reactions of Functionalized Propargylic Substrates. *Eur. J. Org. Chem.* **2015**, 7091–7113.
- (448) Eloy, F.; Deryckere, A.; Maffrand, J. P. New synthesis procedure for imidazole derivatives. *Eur. J. Med. Chem.* **1974**, *9*, 602–606.

- (449) Di Braccio, M.; Grossi, G.; Roma, G.; Vargiu, L.; Mura, M.; Marongiu, M. E. 1,5-Benzodiazepines. Part XII. Synthesis and biological evaluation of tricyclic and tetracyclic 1,5-benzodiazepine derivatives as nevirapine analogues. *Eur. J. Med. Chem.* **2001**, *36*, 935–949.
- (450) McCort, G. A.; Pascal, J. C. A rapid and efficient synthesis of imidazo [1,2-a] and 1,2,4-triazolo [4,3-a]-piperazine carboxylic acids. *Tetrahedron Lett.* **1992**, *33*, 4443–4446.
- (451) Molina, P.; Arques, A.; Vinader, M. V. Preparation of 2,3-dihydrothiazolo[3,2-*c*]quinazolinium salts from 4(3*H*)-quinazolinethiones or 4*H*-1,3-benzothiazine-4-thiones. *Liebigs Ann. der Chemie* **1987**, 103–109.
- (452) Gracias, V.; Darczak, D.; Gasiiecki, A. F.; Djuric, S. W. Synthesis of fused triazolo-imidazole derivatives by sequential van Leusen/alkyne-azide cycloaddition reactions. *Tetrahedron Lett.* **2005**, *46*, 9053–9056.
- (453) Nguyen, H. H.; Palazzo, T. A.; Kurth, M. J. Facile one-pot assembly of imidazotriazolobenzodiazepines *via* indium(III)-catalyzed multicomponent reactions. *Org. Lett.* **2013**, *15*, 4492–4495.
- (454) Tice, C. M.; Bryman, L. M. Regiocontrolled synthesis of 3-substituted-6-trifluoromethyl-4(3*H*)-pyrimidinones. *Tetrahedron* **2001**, *57*, 2689–2700.
- (455) Sosa, A. C. B.; Williamson, R. T.; Conway, R.; Shankar, A.; Sumpter, R.; Cleary, T. A safe and efficient synthetic route to a 2,5-dimethyl-1-aryl-1*H*-imidazole intermediate. *Org. Process Res. Dev.* **2011**, *15*, 449–454.
- (456) Abbiati, G.; Arcadi, A.; Canevari, V.; Rossi, E. Palladium catalyzed synthesis of 4-substituted-2-phenylimidazoles from *N*-propargyl-benzamidine. *Tetrahedron Lett.* **2007**, *48*, 8491–8495.

(457) Bakherad, M.; Nasr-Isfahani, H.; Keivanloo, A.; Doostmohammadi, N. Pd-Cu catalyzed heterocyclization during Sonogashira coupling: synthesis of 2-benzylimidazo[1,2-*a*]pyridine. *Tetrahedron Lett.* **2008**, *49*, 3819–3822.

(458) Li, S.; Li, Z.; Yuan, Y.; Peng, D.; Li, Y.; Zhang, L.; Wu, Y. Au(I)-Catalyzed intramolecular hydroamination of the fluorinated *N'*-aryl-*N*-propargyl amidines: mild conditions for the synthesis of 2-fluoroalkyl imidazole derivatives. *Org. Lett.* **2012**, *14*, 1130–1133.

(459) Li, S.; Li, Z.; Yuan, Y.; Li, Y.; Zhang, L.; Wu, Y. Gold(I)-catalyzed aminohalogenation of fluorinated *N'*-aryl-*N*-propargyl amidines for the synthesis of imidazole derivatives under mild conditions. *Chem. Eur. J.* **2013**, *19*, 1496–1501.

(460) Shen, H.; Xie, Z. Atom-economical synthesis of *N*-heterocycles *via* cascade inter-/intramolecular C-N bond-forming reactions catalyzed by Ti amides. *J. Am. Chem. Soc.* **2010**, *132*, 11473–11480.

(461) Wang, Y.; Shen, H.; Xie, Z. Atom-economical synthesis of 2-aminoimidazoles *via* [3+2] annulation catalyzed by titanacarborane monoamide. *Synlett* **2011**, *7*, 969–973.

(462) Jia, J.-H.; Yu, C.; Xu, M.; Ma, J.-W., Jin, H.-W. Synthesis of imidazole derivatives by cascade reaction: base-mediated addition/alkyne hydroamination of propargylamines and carbodiimides. *Synthesis* **2015**, *47*, 3473–3478.

(463) Pews-Davtyan, A.; Beller, M. A novel Zn-catalyzed hydroamination of propargylamides: a general synthesis of di- and tri-substituted imidazoles. *Chem. Commun.* **2011**, *47*, 2152–2154.

(464) Hong, L.; Shao, Y.; Zhang, L.; Zhou, X. Ln[N(SiMe₃)₂]₃-Catalyzed cross-diinsertion of C≡N/C≡C into an N-H bond: facile synthesis of 1,2,4-trisubstituted imidazoles from propargylamines and nitriles. *Chem. Eur. J.* **2014**, *20* (28), 8551–8555.

(465) Tong, S.; Wang, Q.; Wang, M.-X.; Zhu, J. Tuning the reactivity of isocyano group: synthesis of imidazoles and imidazoliums from propargylamines and isonitriles in the presence of multiple catalysts. *Angew. Chem., Int. Ed.* **2015**, *54*, 1293–1297.

(466) Tong, S.; Wang, Q.; Wang, M. X.; Zhu, J. Switchable [3+2] and [4+2] heteroannulation of primary propargylamines with isonitriles to imidazoles and 1,6-dihydropyrimidines: catalyst loading enabled reaction divergence. *Chem. Eur. J.* **2016**, *22*, 8332–8338.

(467) Zhou, X.; Jiang, Z.; Xue, L.; Lu, P.; Wang, Y. Preparation of 1,2,5-trisubstituted 1*H*-imidazoles from ketenimines and propargylic amines by silver-catalyzed or iodine-promoted electrophilic cyclization reaction of alkynes. *Eur. J. Org. Chem.* **2015**, 5789–5797.

(468) Ghashghaei, O.; Revés, M.; Kielland, N.; Lavilla, R. Modular access to tetrasubstituted imidazolium salts through acid-catalyzed addition of isocyanides to propargylamines *Eur. J. Org. Chem.* **2015**, 4383–4388.

(469) Chiu, S. K.; Dube, M.; Keifer, L.; Szilagyí, S.; Timberlake, J. W. Attempted synthesis of a keto diazene: reactions of propargylic amines, sulfamides, and ureas. *J. Org. Chem.* **1978**, *43*, 61–65.

(470) La-Venia, A.; Medran, N. S.; Krchňák, V.; Testero, S. A. Synthesis of a small library of imidazolidin-2-ones using gold catalysis on solid phase. *ACS Comb. Sci.* **2016**, *18*, 482–489.

(471) Peshkov, V. A.; Pereshivko, O. P.; Sharma, S.; Meganathan, T.; Parmar, V. S.; Ermolat'Ev, D. S.; Van Der Eycken, E. V. Tetrasubstituted 2-imidazolones *via* Ag(I)-catalyzed cycloisomerization of propargylic ureas. *J. Org. Chem.* **2011**, *76*, 5867–5872.

(472) Pereshivko, O. P.; Peshkov, V. A.; Jacobs, J.; Van Meervelt, L.; Van Der Eycken, E. V. Cationic gold- and silver-catalyzed cycloisomerizations of propargylic ureas: a selective

entry to oxazolidin-2-imines and imidazolidin-2-ones. *Adv. Synth. Catal.* **2013**, *355*, 781 – 789.

(473) Proulx, C.; Lubell, W. D. *N*-amino-imidazolin-2-one peptide mimic synthesis and conformational analysis. *Org. Lett.* **2012**, *14*, 4552–4555.

(474) Proulx, C.; Lubell, W. D. Analysis of *N*-amino-imidazolin-2-one peptide turn mimic 4-position substituent effects on conformation by X-ray crystallography. *Pept. Sci.* **2014**, *102*, 7–15.

(475) Ranjan, A.; Yerande, R.; Wakchaure, P. B.; Yerande, S. G.; Dethé, D. H. Base-mediated hydroamination of propargylamine: a regioselective intramolecular *5-exo-dig* cycloisomerization en route to imidazole-2-thione. *Org. Lett.* **2014**, *16*, 5788–5791.

(476) Rosenthal, J.; Lippard, S. J. Direct detection of nitroxyl in aqueous solution using a tripodal copper(II) BODIPY complex. *J. Am. Chem. Soc.* **2010**, *132*, 5536–5537.

(477) Hurtubise, V. L.; McArdle, J. M.; Naeem, S.; Toscani, A.; White, A. J. P.; Long, N. J.; Wilton-Ely, J. D. E. T. Multimetallic complexes and functionalized nanoparticles based on unsymmetrical dithiocarbamate ligands with allyl and propargyl functionality. *Inorg. Chem.* **2014**, *53*, 11740–11748.

(478) Rudolf, B. Synthesis of metallocarbonyl substituted 1,2,3-triazole complexes *via* copper(I)-catalyzed azide – alkyne cycloaddition. *Can. J. Chem.* **2010**, *88*, 991–995.

(479) Pyta, K.; Klich, K.; Domagalska, J.; Przybylski, P. Structure and evaluation of antibacterial and antitubercular properties of new basic and heterocyclic 3-formylrifamycin SV derivatives obtained *via* “click chemistry” approach. *Eur. J. Med. Chem.* **2014**, *84*, 651–676.

(480) Pahimanolis, N.; Hippel, U.; Johansson, L. S.; Saarinen, T.; Houbenov, N.; Ruokolainen, J.; Seppälä, J. Surface functionalization of nanofibrillated cellulose using click-chemistry approach in aqueous media. *Cellulose* **2011**, *18*, 1201–1212.

(481) Crousse, B.; Martinelli, M.; Milcent, T.; Onger, S. Synthesis of new triazole-based trifluoromethyl scaffolds. *Beilstein J. Org. Chem.* **2008**, *4*, 1–4.

(482) Lamarque, J.-F.; Lamarque, C.; Lassara, S.; Médebielle, M.; Molette, J.; David, E.; Pellet-Rostaing, S.; Lemaire, M.; Okada, E.; Shibata, D.; et al. Copper catalyzed 1,3-dipolar cycloaddition reaction of azides with *N*-(2-trifluoroacetylaryl)propargylamines. *J. Fluor. Chem.* **2008**, *129*, 788–798.

(483) Kumbhare, R. M.; Dadmal, T. L.; Ramaiah, M. J.; Kishore, K. S. V; Pushpa Valli, S. N. C. V. L.; Tiwari, S. K.; Appalanaidu, K.; Rao, Y. K.; Bhadra, M. P. Synthesis and anticancer evaluation of novel triazole linked *N*-(pyrimidin-2-yl)benzo[d]thiazol-2-amine derivatives as inhibitors of cell survival proteins and inducers of apoptosis in MCF-7 breast cancer cells. *Bioorganic Med. Chem. Lett.* **2015**, *25*, 654–658.

(484) Haridas, V.; Sharma, Y. K.; Sahu, S.; Verma, R. P.; Sadanandan, S.; Kacheshwar, B. G. Designer peptide dendrimers using click reaction. *Tetrahedron* **2011**, *67*, 1873–1884.

(485) Verma, R. P.; Shandilya, A.; Haridas, V. Peptide dendrimers with designer core for directed self-assembly. *Tetrahedron* **2015**, *71*, 8758–8765.

(486) Matsumura, S.; Hlil, A. R.; Lepiller, C.; Gaudet, J.; Guay, D.; Shi, Z.; Holdcroft, S.; Hay, A. S. Ionomers for proton exchange membrane fuel cells with sulfonic acid groups on the end-groups: novel branched poly(ether-ketone)s. *Am. Chem. Soc. Polym. Prepr. Div. Polym. Chem.* **2008**, *49*, 511–512.

(487) Althuon, D.; Ronicke, F.; Furniss, D.; Quan, J.; Wellhofer, I.; Jung, N.; Schepers, U.; Brase, S. Functionalized triazolo-peptoids - a novel class for mitochondrial targeted delivery. *Org. Biomol. Chem.* **2015**, *13*, 4226–4230.

(488) Ivanysenko, O.; Strandman, S.; Zhu, X. X. Triazole-linked polyamides and polyesters derived from cholic acid. *Polym. Chem.* **2012**, *3*, 1962–1965.

- (489) Salmon, A. J.; Williams, M. L.; Wu, Q. K.; Morizzi, J.; Gregg, D.; Charman, S. A.; Vullo, D.; Supuran, C. T.; Poulsen, S. A. Metallocene-based inhibitors of cancer-associated carbonic anhydrase enzymes IX and XII. *J. Med. Chem.* **2012**, *55*, 5506–5517.
- (490) Ilalia, I.; Beauvineau, C.; Beauvière, S.; Önen, E.; Aufort, M.; Beauvineau, A.; Khaba, E.; Herscovici, J.; Meganem, F.; Girard, C. Automated synthesis of a 96 product-sized library of triazole derivatives using a solid phase supported copper catalyst. *Molecules* **2010**, *15*, 3087–3120.
- (491) Angell, Y.; Burgess, K. Ring closure to β -turn mimics *via* copper-catalyzed azide/alkyne cycloadditions. *J. Org. Chem.* **2005**, *70*, 9595–9598.
- (492) Looper, R. E.; Pizzirani, D.; Schreiber, S. L. Macrocycloadditions leading to conformationally restricted small molecules. *Org. Lett.* **2006**, *8*, 2063–2066.
- (493) Van Maarseveen, J. H.; Horne, W. S.; Ghadiri, M. R. Efficient route to C2 symmetric heterocyclic backbone modified cyclic peptides. *Org. Lett.* **2005**, *7*, 4503–4506.
- (494) Mendoza-Espinosa, D.; Negrón-Silva, G.; Lomas-Romero, L.; Gutiérrez-Carrillo, A.; Santillán, R. Facile one-pot synthesis of 1,2,3-triazoles featuring oxygen, nitrogen, and sulfur functionalized pendant arms. *Synth. Commun.* **2014**, *44*, 807–817.
- (495) Loison, S.; Cottet, M.; Orcel, H.; Adihou, H.; Rahmeh, R.; Lamarque, L.; Trinquet, E.; Kellenberger, E.; Hibert, M.; Durroux, T.; et al. Selective fluorescent nonpeptidic antagonists for vasopressin V 2GPCR: application to ligand screening and oligomerization assays. *J. Med. Chem.* **2012**, *55*, 8588–8602.
- (496) Yu, S.; Wang, N.; Chai, X.; Wang, B.; Cui, H.; Zhao, Q.; Zou, Y.; Sun, Q.; Meng, Q.; Wu, Q. Synthesis and antifungal activity of the novel triazole derivatives containing 1,2,3-triazole fragment. *Arch. Pharm. Res.* **2013**, *36*, 1215–1222.

(497) Yu, S.; Wang, L.; Wang, Y.; Song, Y.; Cao, Y.; Jiang, Y.; Sun, Q.; Wu, Q. Molecular docking, design, synthesis and antifungal activity study of novel triazole derivatives containing the 1,2,3-triazole group. *RSC Adv.* **2013**, *3*, 13486–13490.

(498) Vatmurge, N. S.; Hazra, B. G.; Pore, V. S.; Shirazi, F.; Deshpande, M. V.; Kadreppa, S.; Chattopadhyay, S.; Gonnade, R. G. Synthesis and biological evaluation of bile acid dimers linked with 1,2,3-triazole and bis- β -lactam. *Org. Biomol. Chem.* **2008**, *6*, 3823–3830.

(499) Aafort, M.; Herscovici, J.; Bouhours, P.; Moreau, N.; Girard, C. Synthesis and antibiotic activity of a small molecules library of 1,2,3-triazole derivatives. *Bioorg. Med. Chem. Lett.* **2008**, *18*, 1195–1198.

(500) Raj, R.; Sharma, V.; Hopper, M. J.; Patel, N.; Hall, D.; Wrischnik, L. A.; Land, K. M.; Kumar, V. Synthesis and preliminary in vitro activity of mono- and bis-1H-1,2,3-triazole-tethered β -lactam–isatin conjugates against the human protozoal pathogen *trichomonas vaginalis*. *Med. Chem. Res.* **2014**, *23*, 3671–3680.

(501) Kushwaha, K.; Kaushik, N.; Lata, L.; Jain, S. C. Design and synthesis of novel 2H-chromen-2-one derivatives bearing 1,2,3-triazole moiety as lead antimicrobials. *Bioorganic Med. Chem. Lett.* **2014**, *24*, 1795–1801.

(502) Acquaaah-Harrison, G.; Zhou, S.; Hines, J. V.; Bergmeier, S. C. Library of 1,4-disubstituted 1,2,3-triazole analogs of oxazolidinone RNA-binding agents. *J. Comb. Chem.* **2010**, *12*, 491–496.

(503) Vatmurge, N. S.; Hazra, B. G.; Pore, V. S.; Shirazi, F.; Chavan, P. S.; Deshpande, M. V. Synthesis and antimicrobial activity of β -lactam–bile acid conjugates linked *via* triazole. *Bioorg. Med. Chem. Lett.* **2008**, *18*, 2043–2047.

(504) Reddy, A. B.; Hymavathi, R. V.; Chandrasekhar, T.; Naveen, M.; Swamy, G. N. Synthesis and antimicrobial activity of a new class of methyleneamine-linked bis-heterocycles. *J. Heterocycl. Chem.* **2011**, *48*, 1175–1180.

- (505) Di Pietro, O.; Alencar, N.; Esteban, G.; Viayna, E.; Szałaj, N.; Vázquez, J.; Juárez-Jiménez, J.; Sola, I.; Pérez, B.; Solé, M.; et al. Design, synthesis and biological evaluation of *N*-methyl-*N*-[(1,2,3-triazol-4-yl)alkyl]propargylamines as novel monoamine oxidase B inhibitors. *Bioorg. Med. Chem.* **2016**, *24*, 1–20.
- (506) Key, J. A.; Cairo, C. W. Identification of fluorogenic and quenched benzoxadiazole reactive chromophores. *Dye. Pigment.* **2011**, *88*, 95–102.
- (507) Sakurai, K.; Yamaguchi, T.; Mizuno, S. Design and synthesis of fluorescent glycolipid photoaffinity probes and their photoreactivity. *Bioorganic Med. Chem. Lett.* **2016**, *26*, 5110–5115.
- (508) Chauhan, A.; Paul, R.; Debnath, M.; Bessi, I.; Mandal, S.; Schwalbe, H.; Dash, J. Synthesis of fluorescent binaphthyl amines that bind c-MYC G-quadruplex DNA and repress c-MYC expression. *J. Med. Chem.* **2016**, *59* (15), 7275–7281.
- (509) Yim, D.; Yoon, H.; Lee, C.-H.; Jang, W.-D. Light-driven Au(III)-promoted cleavage of triazole-bearing amine derivatives and its application in the detection of ionic gold. *Chem. Commun.* **2014**, *50*, 12352–12355.
- (510) Temelkoff, D. P.; Zeller, M.; Norris, P. *N*-Glycoside neoglycotrimers from 2,3,4,6-tetra-*O*-acetyl- β -D-glucopyranosyl azide. *Carbohydr. Res.* **2006**, *341*, 1081–1090.
- (511) Godeau, G.; Brun, C.; Arnion, H.; Staedel, C.; Barthélémy, P. Glycosyl-nucleoside fluorinated amphiphiles as components of nanostructured hydrogels. *Tetrahedron Lett.* **2010**, *51*, 1012–1015.
- (512) Wehbie, M.; Arrachart, G.; Karamé, I.; Ghannam, L.; Pellet-Rostaing, S. Triazole diglycolamide cavitand for lanthanide extraction. *Sep. Purif. Technol.* **2016**, *169*, 17–24.
- (513) Liu, S.; Bi, W.; Li, X.; Chen, X.; Qu, L.; Zhao, Y. A practical method to synthesize 1,2,3-triazole-amino-bisphosphonates derivatives. *Phosphorus. Sulfur. Silicon Relat. Elem.* **2015**, *190*, 1735–1742.

(514) Castagnolo, D.; Radi, M.; Dessì, F.; Manetti, F.; Saggi, M.; Meleddu, R.; De Logu, A.; Botta, M. Synthesis and biological evaluation of new enantiomerically pure azole derivatives as inhibitors of mycobacterium tuberculosis. *Bioorg. Med. Chem. Lett.* **2009**, *19* (8), 2203–2205.

(515) Castagnolo, D.; Dessì, F.; Radi, M.; Botta, M. Synthesis of enantiomerically pure α -[4-(1-substituted)-1,2,3-triazol-4-yl]-benzylacetamides *via* microwave-assisted click chemistry: towards new potential antimicrobial agents. *Tetrahedron: Asymmetry* **2007**, *11*, 1345-1350.

(516) Palchak, Z. L.; Nguyen, P. T.; Larsen, C. H. Synthesis of alpha-tetrasubstituted triazoles by coppercatalyzed silyl deprotection/azide cycloaddition. *Beilstein J. Org. Chem.* **2015**, *11*, 1425–1433.

(517) Roy, B.; Mondal, D.; Hatai, J.; Bandyopadhyay, S. A highly efficient tandem [3 + 2] “click” cycloaddition/6-*exo*-cyclization strategy for the construction of triazole fused pyrazines. *RSC Adv.* **2014**, *4*, 56952–56956.

(518) Orgueira, H. A.; Fokas, D.; Isome, Y.; Chan, P. C.-M.; Baldino, C. M. Regioselective synthesis of [1,2,3]-triazoles catalyzed by Cu(I) generated *in situ* from Cu(0) nanosize activated powder and amine hydrochloride salts. *Tetrahedron Lett.* **2005**, *46*, 2911–2914.

(519) Clavadetscher, J.; Hoffmann, S.; Lilienkamp, A.; Mackay, L.; Yusop, R. M.; Rider, S. A.; Mullins, J. J.; Bradley, M. Copper catalysis in living systems and *in situ* drug synthesis. *Angew. Chem., Int. Ed.* **2016**, *55* (50), 15662–15666.

(520) Cao, J.; Xu, G.; Li, P.; Tao, M.; Zhang, W. Polyacrylonitrile fiber supported *N*-heterocyclic carbene Ag(I) as efficient catalysts for three-component coupling and intramolecular 1,3-dipolar cycloaddition reactions under flow conditions. *ACS Sustain. Chem. Eng.* **2017**, *5*, 3438–3447.

(521) Zhang, L.; Chen, X.; Xue, P.; Sun, H. H. Y.; Williams, I. D.; Sharpless, K. B.; Fokin, V. V.; Jia, G. Ruthenium-catalyzed cycloaddition of alkynes and organic azides. *J. Am. Chem. Soc.* **2005**, *127* (46), 15998–15999.

(522) Buysse, K.; Farard, J.; Nikolaou, A.; Vanderheyden, P.; Vauquelin, G.; Sejer Pedersen, D.; Tourwé, D.; Ballet, S. Amino triazolo diazepines (Ata) as constrained histidine mimics. *Org. Lett.* **2011**, *13* (24), 6468–6471.

(523) Pokorski, J. K.; Miller Jenkins, L. M.; Feng, H.; Durell, S. R.; Bai, Y.; Appella, D. H. Introduction of a triazole amino acid into a peptoid oligomer induces turn formation in aqueous solution. *Org. Lett.* **2007**, *9* (12), 2381–2383.

(524) Niu, T. F.; Gu, L.; Wang, L.; Yi, W.; Cai, C. Chemoselective preparation of unsymmetrical bis(1,2,3-triazole) derivatives and application in bis(1,2,3-triazole)-modified peptidomimetic synthesis. *Eur. J. Org. Chem.* **2012**, *34*, 6767–6776.

(525) Niu, T.; Sun, M.; Lv, M.; Yi, W.; Cai, C. Synthesis of highly functionalized macrocycles by tandem multicomponent reactions and intramolecular sonogashira cross-coupling. *Org. Biomol. Chem.* **2013**, *11*, 7232–7238.

(526) Guggenheim, K. G.; Toru, H.; Kurth, M. J. One-pot, two-step cascade synthesis of quinazolinotriazolobenzodiazepines. *Org. Lett.* **2012**, *14*, 3732–3735.

(527) Kumar, R.; Arigela, R. K.; Samala, S.; Kundu, B. Diversity oriented synthesis of indoloazepinobenzimidazole and benzimidazotriazolobenzodiazepine from *N'*-alkyne-1,2-diamines. *Chem. Eur. J.* **2015**, *21*, 18828–18833.

(528) Sudhapriya, N.; Nandakumar, A.; Arun, Y.; Perumal, P. T.; Balachandran, C.; Emi, N. An expedient route to highly diversified [1,2,3]triazolo[1,5-a][1,4]benzodiazepines and their evaluation for antimicrobial, antiproliferative and in silico studies. *RSC Adv.* **2015**, *5*, 66260–66270.

(529) Donald, J. R.; Martin, S. F. Synthesis and diversification of 1,2,3-triazole-fused 1,4-benzodiazepine scaffolds. *Org. Lett.* **2011**, *13*, 852–855.

(530) Wang, Q.; Motika, S. E.; Akhmedov, N. G.; Petersen, J. L.; Shi, X. Synthesis of cyclic amine boranes through triazole-gold(I)-catalyzed alkyne hydroboration. *Angew. Chem., Int. Ed.* **2014**, *53*, 5418–5422.

(531) Mohan, D. C.; Sarang, N. B.; Adimurthy, S. Water mediated deprotective intramolecular hydroamination of *N*-propargylaminopyridines: synthesis of imidazo [1,2-*a*]pyridines. *Tetrahedron Lett.* **2013**, *54*, 6077–6080.

(532) Kaswan, P.; Pericherla, K.; Kumar, A. Ligand-free, copper-catalyzed Ullmann-type C–N coupling : regioselective synthesis of azole-substituted imidazo[1,2-*a*]pyridines. *Synlett* **2013**, *24*, 2751–2757.

(533) Chioua, M.; Soriano, E.; Infantes, L.; Jimeno, M. L.; Marco-Contelles, J.; Samadi, A. Silver-catalyzed cyclization of *N*-(prop-2-yn-1-yl)pyridin-2-amines. *Eur. J. Org. Chem.* **2013**, 35–39.

(534) Chandra Mohan, D.; Nageswara Rao, S.; Adimurthy, S. Synthesis of imidazo[1,2-*a*]pyridines: “water-mediated” hydroamination and silver-catalyzed aminooxygenation. *J. Org. Chem.* **2013**, *78*, 1266–1272.

(535) Patnaik, S.; Marugan, J. J.; Liu, K.; Zheng, W.; Southall, N.; Dehdashti, S. J.; Thorsell, A.; Heilig, M.; Bell, L.; Zook, M.; Eskay, M.; Brimacombe, K. R.; Austin, C. P. Structure-activity relationship of imidazopyridinium analogues as antagonists of neuropeptide S receptor. *J. Med. Chem.* **2013**, *56*, 9045–9056.

(536) Chapman, M. R.; Kwan, M. H. T.; King, G. E.; Kyffin, B. A.; Blacker, A. J.; Willans, C. E.; Nguyen, B. N. Rapid, metal-free and aqueous synthesis of imidazo[1,2-*a*]pyridine under ambient conditions. *Green Chem.* **2016**, *18*, 4623–4627.

(537) Michihiko N.; Hirashi O.; Masanori W.; Kumi O.; Osamu N. Iodocyclization of 3-alkynyl- and 3-allenyl-2-(substituted amino)-1-imidazolin-4-ones. *Tetrahedron* **1996**, *52*, 6581–6590.

(538) Krasnova, L. B.; Hein, J. E.; Fokin, V. V. Synthesis of 7-aza-5-deazapurine analogues via copper(I)-catalyzed hydroamination of alkynes and 1-iodoalkynes. *J. Org. Chem.* **2010**, *75*, 8662–8665.

(539) Beccalli, E. M.; Bernasconi, A.; Borsini, E.; Brogini, G.; Rigamonti, M.; Zecchi, G. Tunable Pd-catalyzed cyclization of indole-2-carboxylic acid allenamides: carboamination vs microwave-assisted hydroamination. *J. Org. Chem.* **2010**, *75*, 6923–6932.

(540) Kumar, A.; Vachhani, D. D.; Modha, S. G.; Sharma, S. K.; Parmar, V. S.; Van der Eycken, E. V. Post-Ugi gold-catalyzed diastereoselective domino cyclization for the synthesis of diversely substituted spiroindolines. *Beilstein J. Org. Chem.* **2013**, *9*, 2097–2102.

(541) Hu, Y.; Yi, R.; Yu, X.; Xin, X.; Wang, C.; Wan, B. O-transfer-facilitated cyclizations of propargylamides with TMSN₃: selective synthesis of tetrazoles and dihydroimidazoles. *Chem. Commun.* **2015**, *51*, 15398–15401.

(542) Sucunza, D.; Samadi, A.; Chioua, M.; Silva, D. B.; Yunta, C.; Infantes, L.; Carmo Carreiras, M.; Soriano, E.; Marco-Contelles, J. A practical two-step synthesis of imidazo[1,2-*a*]pyridines from *N*-(prop-2-yn-1-yl)pyridin-2-amines. *Chem. Commun.* **2011**, *47*, 5043–5045.

(543) Ramesh, S.; Ghosh, S. K.; Nagarajan, R. Copper catalyzed synthesis of fused benzimidazolopyrazine derivatives via tandem benzimidazole formation/annulation of δ -alkynyl aldehyde. *Org. Biomol. Chem.* **2013**, *11*, 7712–7720.

(544) Li, R.-L.; Liang, L.; Xie, M.-S.; Qu, G.-R.; Niu, H.-Y.; Guo, H.-M. Copper-catalyzed intramolecular cyclization of *N*-propargyl-adenine: synthesis of purine-fused tricyclics. *J. Org. Chem.* **2014**, *79*, 3665–3670.

(545) Chinchilla, R.; Nájera, C. The Sonogashira reaction: a booming methodology in synthetic organic chemistry. *Chem. Rev.* **2007**, *107*, 874–922.

(546) Chinchilla, R.; Najera, C. Recent advances in Sonogashira reactions. *Chem. Soc. Rev.* **2011**, *40*, 5084–5121.

(547) Gotteland, J.-P.; Dax, C.; Halazy, S. Design and synthesis of new potential photoaffinity labels for mammalian squalene epoxidase. *Bioorg. Med. Chem. Lett.* **1997**, *7*, 1153–1156.

(548) Conn, C.; Shimmon, R.; Cordaro, F.; Hargraves, T.-L.; Ibrahim, P. Combinatorial synthesis of SSAO inhibitors using Sonogashira coupling: SAR of aryl propargylic amines. *Bioorg. Med. Chem. Lett.* **2001**, *11*, 2565–2568.

(549) Merkul, E.; Muller, T. J. J. A new consecutive three-component oxazole synthesis by an amidation-coupling-cycloisomerization (ACCI) sequence. *Chem. Commun.* **2006**, 4817–4819.

(550) Chaudhuri, G.; Kundu, N. G. A highly regio- and stereoselective synthesis of (Z)-3-arylidene-2,3-dihydro-5H-1,4-benzodioxepin-5-ones and (Z)-3-arylidene-1,2,3,5-tetrahydro-4,1-benzoxazepin-5-ones through palladium-copper catalysis. *J. Chem. Soc. Perkin Trans. 1* **2000**, 775–779.

(551) Kundu, N. G.; Chaudhuri, G. Copper-catalysed heteroannulation with alkynes: a general and highly regio- and stereoselective method for the synthesis of (E)-2-(2-arylvinyl) quinazolinones. *Tetrahedron* **2001**, *57*, 6833–6842.

(552) Mahanty, J. S.; De, M.; Kundu, N. G. Palladium-catalysed heteroannulation of vinylic compounds: a highly convenient method for the synthesis of N-aryl-1,2,3,4-tetrahydro-1-oxoisoquinoline-3-carboxylic acids. *J. Chem. Soc. Perkin Trans. 1* **1997**, 2577–2580.

(553) Chowdhury, C.; Chaudhuri, G.; Guha, S.; Mukherjee, A. k.; Kundu, N. G. Palladium-catalyzed heteroannulation leading to heterocyclic structures with two heteroatoms: a highly

convenient and facile method for a totally regio- and stereoselective synthesis of (Z)-2,3-dihydro-2-(ylidene)-1,4-benzo- and -naphtho[2,3-*b*]dioxins. *J. Org. Chem.* **1998**, *63*, 1863–1871.

(554) Kundu, N. G.; Chaudhuri, G.; Upadhyay, A. Palladium-catalyzed heteroannulation leading to heterocyclic structures with two heteroatoms: a highly regio- and stereoselective synthesis of (Z)-4-alkyl-2-alkyl(aryl)idene-3,4-dihydro-2H-1,4-benzoxazines and (Z)-3-alkyl(aryl)idene-4-tosyl-3,4-dihydro-2H-1,4-benzoxazines. *J. Org. Chem.* **2001**, *66*, 20-29.

(555) Kore, A. R.; Senthilvelan, A.; Shanmugasundaram, M. Highly regioselective C-5 iodination of pyrimidine nucleotides and subsequent chemoselective Sonogashira coupling with propargylamine. *Nucleosides, Nucleotides and Nucleic Acids* **2015**, *34*, 92–102.

(556) Borsenberger, V.; Kukwikila, M.; Howorka, S. Synthesis and enzymatic incorporation of modified deoxyuridine triphosphates. *Org. Biomol. Chem.* **2009**, *7*, 3826–3835.

(557) Matulic-Adamic, J.; Daniher, A. T.; Karpeisky, A.; Haerberli, P.; Sweedler, D.; Beigelman, L. Functionalized nucleoside 5-triphosphates for in vitro selection of new catalytic ribonucleic acids. *Bioorg. Med. Chem. Lett.* **2000**, *10*, 1299–1302.

(558) Jäger, S.; Rasched, G.; Kornreich-Leshem, H.; Engeser, M.; Thum, O.; Famulok, M. A versatile toolbox for variable DNA functionalization at high density. *J. Am. Chem. Soc.* **2005**, *127*, 15071–15082.

(559) Nelson, J. C.; Young, J. K.; Moore, J. S. Solid-phase synthesis of phenylacetylene oligomers utilizing a novel 3-propyl-3-(benzyl-supported) triazene linkage. *J. Org. Chem.* **1996**, *61*, 8160–8168

(560) Bolton, G. L.; Hodges, J. C.; Rubin, J. R. Solid phase synthesis of fused bicyclic amino acid derivatives *via* intramolecular Pauson-Khand cyclization: versatile scaffolds for combinatorial chemistry. *Tetrahedron* **1997**, *53*, 6611–6634.

(561) Dyatkin, A. B.; Rivero, R. A. The solid phase synthesis of complex propargylamines using the combination of Sonogashira and Mannich reactions. *Tetrahedron Lett.* **1998**, *39*, 3647–3650.

(562) Beilstein, A. E.; Grinstaff, M. W. Synthesis and characterization of ferrocene-labeled oligodeoxynucleotides. *J. Organomet. Chem.* **2001**, *637-639*, 398-406.

(563) Stieber, F.; Grether, U.; Waldmann, H. An oxidation-labile traceless linker for solid-phase synthesis. *Angew. Chem., Int. Ed.* **1999**, *38*, 1073–1077.

(564) Huang, S.; Tour, J. M. Rapid solid-phase synthesis of oligo(1,4-phenylene ethynylene)s by a divergent/convergent tripling strategy. *J. Am. Chem. Soc.* **1999**, *121*, 4908–4909.

(565) Cassel, J. A.; Leue, S.; Gachkova, N. I.; Kann, N. C. Solid-phase synthesis of substituted alkynes using the Nicholas reaction. *J. Org. Chem.* **2002**, *67*, 9460–9463.

(566) Hudson, R. H. E.; Li, G.; Tse, J. The use of Sonogashira coupling for the synthesis of modified uracil peptide nucleic acid. *Tetrahedron Lett.* **2002**, *43*, 1381–1386.

(567) Erdélyi, M.; Gogoll, A. Rapid microwave promoted Sonogashira coupling reactions on solid phase. *J. Org. Chem.* **2003**, *68*, 6431–6434.

(568) Louërat, F.; Gros, P.; Fort, Y. Solid phase palladium-catalysed C-C bond formation in the pyridine series: access to aryl and alkynyl pyridylpiperazines. *Tetrahedron Lett.* **2003**, *44*, 5613–5616

(569) Spivey, A. C.; McKendrick, J.; Srikanan, R.; Helm, B. A. Solid-phase synthesis of an A–B loop mimetic of the Cε3 domain of human IgE: macrocyclization by Sonogashira coupling. *J. Org. Chem.* **2003**, *68*, 1843–1851.

(570) Filichev, V. V.; Pedersen, E. B. Stable and selective formation of Hoogsteen-type triplexes and duplexes using twisted intercalating nucleic acids (TINA) prepared *via*

postsynthetic Sonogashira solid-phase coupling reactions. *J. Am. Chem. Soc.* **2005**, *127*, 14849–14858

(571) Yao, T.; Yue, D.; Larock, R. Solid-phase synthesis of 1,2,3-trisubstituted indoles and 2,3-disubstituted benzofurans *via* iodocyclization. *J. Comb. Chem.* **2005**, *7*, 809–812.

(572) Tulla-Puche, J.; Barany, G. Development of resin-to-resin transfer reactions (RRTR) using Sonogashira chemistry. *Tetrahedron* **2005**, *61*, 2195–2201.

(573) Khan, S. I.; Grinstaff, M. W. Palladium(0)-catalyzed modification of oligonucleotides during automated solid-phase synthesis. *J. Am. Chem. Soc.* **1999**, *121*, 4704–4705.

(574) Pattarawarapan, M.; Chen, J.; Steffensen, M.; Burgess, K. A rigid linker-scaffold for solid-phase synthesis of dimeric pharmacophores. *J. Comb. Chem.* **2001**, *3*, 102–116.

(575) Rawat, D. S.; Zaleski, J. M. Syntheses and thermal reactivities of symmetrically and asymmetrically substituted acyclic enediynes: steric control of Bergman cyclization temperatures. *Chem. Commun.* **2000**, 2493–2494.

(576) Yalagala, R. S.; Zhou, N.; Yan, H. Palladium(II)–copper(I) mediated homotrimerization and homotetramerization of terminal alkynes. *Tetrahedron Lett.* **2014**, *55*, 1883–1885.

(577) Yalagala, R. S.; Yan, H. Reactions of alkynes with trisubstituted (*Z*)-bromoalkenyl-pinacolboronates towards the synthesis of 1,2,4,6-tetrasubstituted benzenes. *Tetrahedron Lett.* **2014**, *55*, 4830–4832.

(578) Chandra, T.; Pink, M.; Zaleski, J. M. Macrocyclic metalloenediynes of Cu(II) and Zn(II): a thermal reactivity comparison. *Inorg. Chem.* **2001**, *40*, 5878–5885.

(579) Zhang, W.; Cheng, J.; Ding, L.; Zhong, P.; Zhao, L.; Wu, H. Copper- and amine-free Sonogashira reaction of *N,N*-disubstituted propargylamine: synthesis of substituted aryl propargylamine. *Synth. Commun.* **2006**, *36*, 2001–2007.

(580) Nakamura, H.; Kamakura, T.; Ishikura, M.; Biellmann, J.-F. Synthesis of allenes *via* palladium-catalyzed hydrogen transfer reactions: propargylic amines as an allenyl anion equivalent. *J. Am. Chem. Soc.* **2004**, *126*, 5958–5959.

(581) Nakamura, H.; Onagi, S. Synthesis and biological evaluation of allenic quinazolines using palladium-catalyzed hydride-transfer reaction. *Tetrahedron Lett.* **2006**, *47*, 2539–2542.

(582) Luo, H.; Ma, S. CuI-catalyzed synthesis of functionalized terminal allenes from 1-alkynes. *Eur. J. Org. Chem.* **2013**, 3041–3048.

(583) Peshkov, V. A.; Pereshivko, O. P.; Donets, P. A.; Mehta, V. P.; Van der Eycken, E. V. Diversity-oriented microwave-assisted synthesis of the 3-benzazepine framework. *Eur. J. Org. Chem.* **2010**, 4861–4867.

(584) Peshkov, A. A.; Peshkov, V. A.; Pereshivko, O. P.; Van Hecke, K.; Kumar, R.; V. Van Der Eycken, E. Heck-Suzuki tandem reaction for the synthesis of 3-benzazepines. *J. Org. Chem.* **2015**, *80*, 6598–6608.

(585) Consorti, C. S.; Zanini, M. L.; Leal, S.; Ebeling, G.; Dupont, J. Chloropalladated propargyl amine: a highly efficient phosphine-free catalyst precursor for the Heck reaction. *Org. Lett.* **2003**, *5*, 983–986.

(586) T. Diver, S. T.; Giessert, A. J. Enyne metathesis (enyne bond reorganization). *Chem. Rev.* **2004**, *104*, 1317–1382.

(587) Smulik, J. A.; Diver, S. T. Expanded scope in ethylene–alkyne cross-metathesis: coordinating heteroatom functionality at the propargylic position. *Org. Lett.*, **2000**, *2*, 2271–2274.

(588) Castagnolo, D.; Renzulli, M. L.; Galletti, E.; Corelli, F.; Botta, M. Microwave-assisted ethylene–alkyne cross-metathesis: synthesis of chiral 2-(N-1-acetyl-1-arylmethyl)-1,3-butadienes. *Tetrahedron: Asymm.* **2005**, *16*, 2893–2896.

(589) Castagnolo, D.; Giorgi, G.; Spinosa, R.; Corelli, F.; Botta, M. Practical syntheses of enantiomerically pure *N*-acetylbenzhydramines. *Eur. J. Org. Chem.* **2007**, 3676-3686.

(590) Castagnolo, D.; Botta, L.; Botta, M. One-pot multicomponent synthesis of 2,3-dihydropyrans: new access to furanose–pyranose 1,3-C–C-linked-disaccharides. *Tetrahedron Lett.* **2009**, *50*, 1526-1528.

(591) Barrett, A. G. M.; Hennessy, A. J.; Le Vézouët, R.; Procopiou, P. A.; Seale, P. W.; Stefaniak, S.; Upton, R. J.; White, A. J. P.; Williams, D. J. Synthesis of diverse macrocyclic peptidomimetics utilizing ring-closing metathesis and solid-phase synthesis. *J. Org. Chem.* **2004**, *69*, 1028-1037.

(592) Beckmann, H. S. G.; Nie, F.; Hagerman, C. E.; Johansson, H.; Tan, Y. S.; Wilcke, D.; Spring, D. R. A strategy for the diversity-oriented synthesis of macrocyclic scaffolds using multidimensional coupling. *Nature Chem.* **2013**, *5*, 861–867.

(593) Nie, F.; Kunciw, D. L.; Wilcke, D.; Stokes, J. E.; Galloway, W. R. J. D.; Bartlett, S.; Sore, H. F.; Spring, D. R. A multidimensional diversity-oriented synthesis strategy for structurally diverse and complex macrocycles. *Angew. Chem., Int. Ed.* **2016**, *55*, 11139–11143.

(594) Hansen, E. C.; Lee, D. Ring closing enyne metathesis: control over mode selectivity and stereoselectivity. *J. Am. Chem. Soc.* **2004**, *126*, 15074–15080.

(595) Solé, D.; Bannasar, M.-L.; Roca, T.; Valldosera, M. Exploration of ring-closing enyne metathesis for the synthesis of azonino[5,4-*b*]indoles. *Eur. J. Org. Chem.* **2016**, 1355–1366.

(596) Hong, F.-E.; Huang, Y.-L.; Chen, H.-L. Observations on reaction pathways of dicobalt octacarbonyl with alkynyl amines. *J. Organomet. Chem.* **2004**, *689*, 3449–3460.

(597) Hong, F.-E.; Chang, Y.-C. Density functional studies on dicobalt octacarbonyl mediated urea formation from primary amine. *Organometallics* **2004**, *23*, 718–729.

(598) Ji, Y.; Riera, A.; Verdaguer, X. Saline intermolecular Pauson-Khand reactions of propargyl amine. *Eur. J. Org. Chem.* **2011**, 1438–1442.

(599) Aiguabella, N.; Pesquer, A.; Verdaguer, X.; Riera, A. Pauson–Khand adducts of *N*-Boc-propargylamine: a new approach to 4,5-disubstituted cyclopentenones. *Org. Lett.* **2013**, *15*, 2696–2699.

(600) Sturla, S. J.; Buchwald, S. L. Catalytic asymmetric cyclocarbonylation of nitrogen-containing enynes. *J. Org. Chem.* **1999**, *64*, 5547–5550.

Table of contents (TOC) graphic

